



FOUR WINNS®

EXPERIENCE. THE DIFFERENCE





FOUR WINNS[®]

FOUR WINNS L.L.C., 925 Frisbie Street, Cadillac, MI 49601 Phone (231) 775-1343

WARRANTY REGISTRATION TRANSFER REQUEST

Original Owner Name & Address: _____

Original Date of Purchase: _____

Hull Identification Number: _____

Boat Model: _____

Selling Dealer: _____

Name and address of new purchaser: _____

Telephone & E-Mail Address: _____

Date of Purchase: _____

Transfer Fee: \$250.00 – All models.

The warranty may be transferred only once. Registration of the second owner is required and the amount of the transfer fee is \$250.00. Transfer of the remainder of the warranty must occur within five (5) years of the original retail sale. The transfer fee must be paid within fifteen (15) days of purchase of the used boat by check, money order or cashier's check payable to Four Winns. We will notify the appropriate engine manufacturer of the engine warranty transfer.

This warranty registration request if accepted, transfers the warranty coverage remaining on the boat to the new purchaser. Acceptance of this request does not create any additional warranties or obligation on Four Winns.

Warranty Expiration Date: _____

Four Winns Transfer Acceptance Date: _____

Four Winns Authorized Signature: _____

Mail to Four Winns L.L.C., 925 Frisbie Street, Cadillac, MI 49601, Attn: Customer Service Department.



FOUR WINNS[®]

NAME / ADDRESS CHANGE FORM

Name & Address:

PLEASE PRINT CLEARLY.

Telephone & E-Mail Address:

Hull Identification Number:

Boat Model:

Date of Purchase:

NOTE: For warranty transfer please use the Warranty Transfer Request Form also included in front of manual.

PLEASE FOLD IN HALF & SEAL.



FOUR WINNS[®]

NAME / ADDRESS CHANGE FORM

Name & Address:

PLEASE PRINT CLEARLY.

Telephone & E-Mail Address:

Hull Identification Number:

Boat Model:

Date of Purchase:

NOTE: For warranty transfer please use the Warranty Transfer Request Form also included in front of manual.

PLEASE FOLD IN HALF & SEAL.



FOUR WINNS[®]

NAME / ADDRESS CHANGE FORM

Name & Address:

PLEASE PRINT CLEARLY.

Telephone & E-Mail Address:

Hull Identification Number:

Boat Model:

Date of Purchase:

NOTE: For warranty transfer please use the Warranty Transfer Request Form also included in front of manual.

PLEASE FOLD IN HALF & SEAL.

TO: Four Winns L.L.C.
925 Frisbie Street
Cadillac, MI 49601

Attn: Customer Service Department.

PLEASE
PLACE
STAMP
HERE.

TO: Four Winns L.L.C.
925 Frisbie Street
Cadillac, MI 49601

Attn: Customer Service Department.

PLEASE
PLACE
STAMP
HERE.

TO: Four Winns L.L.C.
925 Frisbie Street
Cadillac, MI 49601

Attn: Customer Service Department.

PLEASE
PLACE
STAMP
HERE.

PREFACE

This manual will acquaint you with the use and maintenance of your new Four Winns boat. This manual also provides special information critical to the safety of the passengers, and longevity of the equipment. The information on the following page lists the graphics used to increase the visibility of these important messages. Also included in your owner's packet is the "Boating Basics, A Guide to Responsible Boating". This publication covers the boating basics and should be read along with your Four Winns Owner's Manual before operating your boat. Review this information completely before using your new boat.

Four Winns continually strives to improve its products. Unit specifications, including standard and optional equipment are constantly being modified. **Equipment availability is also subject to change. The most current and accurate information available at the time of publication is included in this manual. Some variation in equipment, description, location, and details can result.**

The information in this manual focuses upon the equipment designed and manufactured by Four Winns on specific models. When appropriate, please utilize the information pertinent to your specific boat model.

Equipment such as engines, and other accessories are manufactured by others. The information provided in this manual is intended to be used in conjunction with the information provided by the manufacturers of this equipment. All information available at the time of manufacture has been included with your owner's packet.

Read this entire manual carefully before operating your new boat. Many instructions may require direct performance of the activity to fully understand the correct method. If you choose to read this manual at home, remember to take it to the boat with you.

Your Four Winns dealer knows your boat best and is interested in your complete satisfaction. Return to the dealer for service or other assistance. If you find it necessary to contact Four Winns directly, please refer to the address information listed below. Be sure to include the boat model, hull identification number, your daytime telephone number, and specifics of the information desired.

This manual has been specifically developed for the Funship™ models. Please record the model and hull identification number information below.

Model

Hull Identification Number

This manual should be considered part of the boat. Should you sell the boat, pass this manual on to the new owner. Take special care of this manual. Certain information in this manual may not be available in a replacement manual.

Thank you for joining the Four Winns family. We appreciate your purchase and welcome the opportunity to demonstrate our commitment to you.

**Four Winns Customer Service Department
925 Frisbie Street
Cadillac, Michigan 49601
231-775-1343 (Phone)
231-779-2345 (FAX)
E-Mail Address: boating@fourwinns.com
©FOUR WINNS L.L.C. 2003. All Rights Reserved.**

Congratulations on your new boat purchase and welcome to our boating family!

We want your boating experience to be the most enjoyable possible. The more you know about your new boat, the more you'll enjoy the time you spend aboard. That's why we prepared this manual. It's your guide for safe operation as well as understanding your boat's system and equipment. It has been written for the beginning boater but experienced boaters will find helpful information as well. Be sure to read the contents thoroughly.

The popularity of boating and other water sports has grown tremendously in the past few years. Because of this, safety is an important issue for everyone who shares our waterways.

Remember that along with the freedom and exhilaration of boating comes the responsibility that you have for the safety of your passengers and the other boaters who share the water with you. Throughout this manual, specific precautions and symbols identify safety-related information. Be sure to pay close attention to them.

 This symbol means "pay attention!" Here is important information for your safety. If you don't follow these instructions, you can damage your boat, hurt yourself or someone else or, even worse, have a fatal accident.

 **CAUTION**

This symbol and signal word indicate a potentially hazardous situation. If you ignore this safety message, property damage or minor or moderate personal injury MAY or CAN result.

 **WARNING**

This symbol and signal word indicate a potential hazard. If you ignore this safety message, serious injury or death CAN result.

 **DANGER**

This symbol and signal word indicates an immediate hazard. If you ignore this safety message, serious personal injury or death WILL result.

The precautions in this manual can't and don't cover every boating situation. If a specific method or procedure is not recommended, you must make sure that what you do is safe for you and others. Always use common sense when boating! Remember to make sure that every safe boating excursion is a happy experience.

We'd also like to remind you to be kind to our environment while you're boating. Don't throw garbage and other refuse overboard. Do your best to keep harmful compounds like gasoline and antifreeze out of the water.

This manual has been compiled to help you operate your boat with safety and pleasure. It contains the details of the boat, the equipment supplied or fitted, its systems, and information on its operation and maintenance. Please read it carefully and familiarize yourself with the boat before using it.

If this is your first boat, or if you are changing to a type of boat you are not familiar with, for your own comfort and safety, please ensure that you obtain handling and operating experience before "assuming command" of the boat. Your dealer or national sailing federation or yacht club will be pleased to advise you of local sea schools and competent instructors.

PLEASE KEEP THIS MANUAL IN A SECURE PLACE, AND HAND IT OVER TO THE NEW OWNER WHEN YOU SELL THE BOAT.

LABEL LOCATIONS

The NMMA capacity label and various warning labels are placed at different locations on each model for your safety. Additional warnings for fuel leakage, blower operation, and other important information will be imprinted or located on the dash. Many of these stickers and labels are not required by the U.S. Coast Guard but are important to ensure the safe operation of your Four Winns® boat. In addition, the Hull Identification Number plate is permanently attached below the deck-hull joint on the starboard aft corner.

Below are letters corresponding to the various locations for each item on the drawings. See pages 4-8 for the actual wording of each of the various warning labels found on your boat.

- | | |
|--------------------------------------|--------------------------------------|
| (A) Hull Identification Number Plate | (B) Gasoline Vapor-Blower Warning |
| (C) Helm Boarding Ladder Warning | (D) Rotating Prop Boarding Ladder |
| (E) Leaking Fuel | (F) CO Swim Platform & Lounging Area |
| (G) Capacity Label | (H) Ski Tow Warning |
| (I) Winning Edge Sticker | (J) NMMA Certified |
| (K) Flush Out Caution (Optional) | |



A



B

C



D

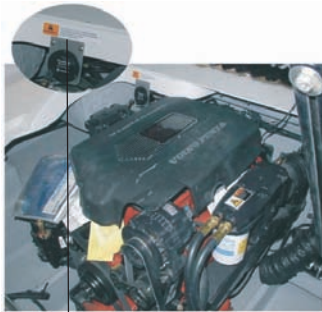

E



F

G



H



I



J

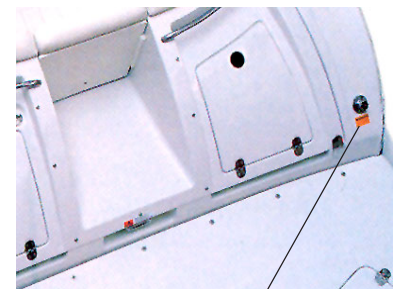

K

Figure 1: Funship™ Models

CAPACITY & WARNING LABELS

MAXIMUM CAPACITIES

13 PERSONS OR 1850 LBS.

1900 LBS, PERSONS, GEAR

THIS BOAT COMPLIES WITH U.S. COAST GUARD SAFETY STANDARDS IN EFFECT ON THE DATE OF CERTIFICATION
MANUFACTURER: FOUR WINNS CADILLAC MI 49601

MODEL: 214 FUNSHIP-02

DESIGN COMPLIANCE WITH NMMA REQUIREMENTS BELOW IS VERIFIED.
MANUFACTURER RESPONSIBLE FOR PRODUCTION CONTROL.

LOAD CAPACITY * COMPARTMENT VENTILATION
STEERING, FUEL AND ELECTRICAL SYSTEMS
INTERNATIONAL LIGHTS * BASIC FLOTATION
MANEUVERABILITY



NATIONAL MARINE MANUFACTURERS ASSOCIATION

G. 214 Funship™ Capacity Label

MAXIMUM CAPACITIES

13 PERSONS OR 1950 LBS.

2050 LBS, PERSONS, GEAR

THIS BOAT COMPLIES WITH U.S. COAST GUARD SAFETY STANDARDS IN EFFECT ON THE DATE OF CERTIFICATION
MANUFACTURER: FOUR WINNS CADILLAC MI 49601

MODEL: 234 FUNSHIP-02

DESIGN COMPLIANCE WITH NMMA REQUIREMENTS BELOW IS VERIFIED.
MANUFACTURER RESPONSIBLE FOR PRODUCTION CONTROL.

LOAD CAPACITY * COMPARTMENT VENTILATION
STEERING, FUEL AND ELECTRICAL SYSTEMS
INTERNATIONAL LIGHTS * BASIC FLOTATION
MANEUVERABILITY



NATIONAL MARINE MANUFACTURERS ASSOCIATION

G. 234 Funship™ Capacity Label

G. 264 Funship™ Capacity Label

MAXIMUM CAPACITIES

15 PERSONS OR 2250 LBS.

2300 LBS, PERSONS, GEAR

THIS BOAT COMPLIES WITH U.S. COAST GUARD SAFETY STANDARDS IN EFFECT ON THE DATE OF CERTIFICATION
MANUFACTURER: FOUR WINNS CADILLAC, MI 49601

MODEL: 264 FUNSHIP-03

DESIGN COMPLIANCE WITH NMMA REQUIREMENTS BELOW IS VERIFIED.
MANUFACTURER RESPONSIBLE FOR PRODUCTION CONTROL.

LOAD CAPACITY * COMPARTMENT VENTILATION
STEERING, FUEL AND ELECTRICAL SYSTEMS
NAVIGATION LIGHTS * BASIC FLOTATION
MANEUVERABILITY



NATIONAL MARINE MANUFACTURERS ASSOCIATION



Imprinted Labels on Port Ignition Panel

B.



WARNING

GASOLINE VAPORS CAN EXPLODE RESULTING IN INJURY OR DEATH. BEFORE STARTING ENGINE -CHECK ENGINE BILGE COMPARTMENT FOR GASOLINE OR VAPORS, AND -OPERATE BLOWER FOR FOUR MINUTES, AND VERIFY BLOWER OPERATION. RUN BLOWER WHEN VESSEL IS OPERATING BELOW CRUISING SPEED.

C.



WARNING

ROTATING PROPELLER CAN CAUSE SERIOUS INJURY OR DEATH. SHUT OFF MOTOR WHEN NEAR PERSONS IN WATER.

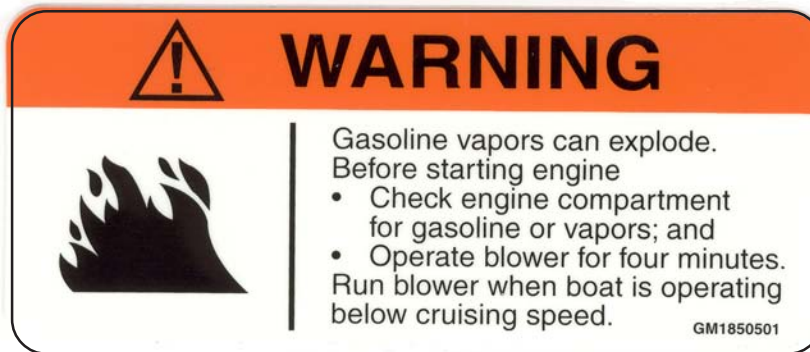

B. Gasoline Vapor-Blower Warning Label



C. Rotating Propeller - Helm Warning Label

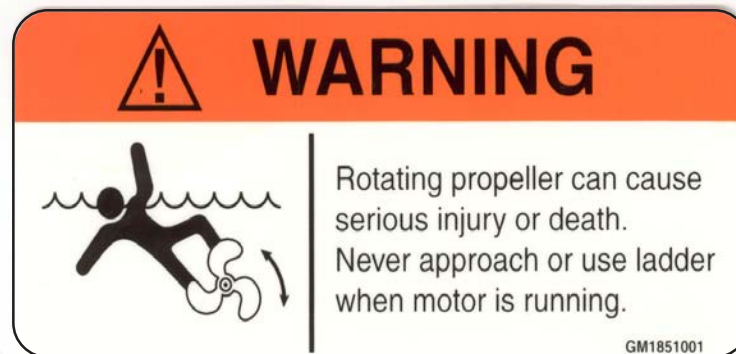

D. Rotating Propeller - Ladder Warning Label



E. Leaking Fuel Warning Label



WARNING

Carbon monoxide is produced by all gasoline engines and generator sets. To avoid brain damage or death from carbon monoxide, keep cockpit and cabin area well ventilated, and avoid blockage of exhaust outlets. Do not occupy swim platform or aft lounging area when engine or generator is running. Signs of exposure include nausea, dizziness and drowsiness. See owner's manual for more information.

GM1850101

F. CO Swim Platform & Lounging Area Warning Label



WARNING

Do not use ski tow fitting for lifting or parasailing. Fitting could pull out of deck resulting in serious injury or death.

GM1850801

H. Ski Tow Warning Label



WARNING

Fuel vapors are a fire and explosion hazard. To avoid injury or death, do not store fuel or flammable liquids here.

GM1850701

No Ventilation - Do Not Store Fuel Warning Label
(Location Not Shown)



WARNING

Prevent falls overboard. Close, latch and stay inside gate(s) while underway.

GM1851101

Transom/Side Door Warning Label
(Location Not Shown)



I. Winning Edge Sticker



J. NMMA Certified Sticker



K. Flush Out Warning Label (Optional)

TABLE OF CONTENTS

OPERATION	1
A - 1 GENERAL	1
A - 2 COMPONENT SYSTEMS	1
A - 3 SAFETY EQUIPMENT	1
A - 4 PASSENGER SAFETY	1
A - 5 "RULES OF THE ROAD"	1
A - 6 LIGHTNING	1
A - 7 DRUGS AND ALCOHOL	2
A - 8 PRE-CRUISE SYSTEM CHECK	2
A. Before Starting The Engine	2
B. After Starting The Engine	2
A - 9 ENGINE OPERATIONAL PROCEDURES	2
A. Before Starting	2
B. Cold Engine Start (Carbureted Engines)	3
C. Warm Engine Starting	3
D. Shifting and Control Speed	4
E. Stopping Engine	4
A - 10 GROUNDING AND TOWING	4
A - 11 BOATING EDUCATION	5
A. Boating Courses	5
B. Boating Manuals or Literature	5
C. Charts and Maps	5
D. Laws and Regulations	5
A - 12 BOAT OWNER REGISTRATION	6
A - 13 INSURANCE	6
A - 14 ACCIDENT REPORTING	6
A - 15 DISCHARGE OF OIL	6
A - 16 DISPOSAL OF PLASTICS & OTHER GARBAGE	7
A - 17 MARPOL TREATY	7
BOATING SAFETY	1
B - 1 GENERAL	1
A. Required Safety Equipment	1
B. Personal Floatation Devices (PFD's)	1
C. PFD Types	1
D. PFD Pointers	2
E. Emergency Stop Switch	2
F. Fire Extinguisher	3
G. Visual Distress Signal Devices	3
H. Sound Signaling Devices	4
I. Navigation Lights	4
J. Additional Recommended Equipment	4
B - 2 CARBON MONOXIDE	4
A. Properties and Characteristics of Carbon Monoxide	5
B. What Makes Carbon Monoxide	5
C. How a Person is Affected by Carbon Monoxide	5

	D.	Effects of Carbon Monoxide	5
	E.	Symptoms	5
	F.	Treatment (Evaluate, Ventilate, Evacuate, Investigate, Take Corrective Action)	6
	G.	Inspection	6
	H.	Operation	6
	I.	Boathouses, Sea Walls and Other Boats	6
	J.	Backdrafting (Station Wagon Effect)	7
	K.	Cabin Appliances	8
	L.	Ventilation of Accommodation Spaces	8
	M.	Altitude and Sea Conditions	8
	N.	Running of Engines in Idle	8
	O.	Portable Generator Sets	8
	P.	Maintenance - Engine Performance	8
	Q.	Maintenance - External Conditions	9
B - 3		SAFE BOATING PRACTICES	9
	A.	Drugs and Alcohol	9
	B.	Safe Operation	9
	C.	Passenger Safety	10
	D.	Propeller	10
	E.	First Aid	10
	F.	Operation By Minors	10
	G.	"Rules of the Road"	10
	H.	Voluntary Inspection	10
	I.	Safe Boating Courses	10
B - 4		WATER SPORTS	11
	A.	Water Sport Guidelines	11
	B.	Water Skiing	11
BASIC SEAMANSHIP			1
C - 1		GENERAL	
	A.	Boating Regulations	1
	B.	Rules of Seamanship	1
C - 2		NAVIGATIONALAIDS	3
	A.	International Association of Lighthouse Authorities System B (IALA-B)	3
	B.	Lateral Markers	3
	C.	Safe Water Markers	3
	D.	The Uniform State Waterway Marking System	4
	E.	A Special Sign	4
	F.	Noise	4
C - 3		RECOMMENDED READING	4
C - 4		CONTACTS	4
C - 5		OWNER'S LOGS AND RECORDS	5
C - 6		NAVIGATIONALAIDS CHART	5
WARRANTY AND SERVICE			1
D - 1		FOUR WINNS WARRANTY POLICY	1
D - 2		DECK/HULL STRUCTURE WARRANTY	1
D - 3		WARRANTY REGISTRATION	1
D - 4		TRANSFER OF WARRANTY	1
D - 5		PRE-OWNED UNIT REGISTRATION	1
D - 6		INSURANCE COVERAGE	2
D - 7		SERIAL NUMBER RECORD	2
D - 8		PRE-DELIVERY SERVICE	2

D - 9	REPLACEMENT PARTS	2
D - 10	OWNER'S RESPONSIBILITIES	3
D - 11	CONSTRUCTION STANDARDS	3
D - 12	WINNGEAR™	3
ENGINES AND INSTRUMENTATION		1
E - 1	GENERAL	1
E - 2	ENGINE EXHAUST	1
E - 3	ENGINES	2
E - 4	PROPELLERS	2
	A. Diameter	2
	B. Pitch	2
	C. Prop Slip	2
E - 5	RUNNING ANGLE & POWER TRIM/TILT	3
	A. Power Trim	3
	B. Power Tilt	3
E - 6	ENGINE INSTRUMENTATION	3
	A. Tachometer	4
	B. Speedometer	4
	C. Temperature Gauge (4-in-1 Gauge)	5
	D. Oil Pressure Gauge (4-in-1 Gauge)	5
	E. Voltmeter (4-in-1 Gauge)	5
	F. Fuel Gauge (4-in-1 Gauge)	5
	G. Power Trim Gauge	5
	H. Depthsounder	5
	I. Ignition Switch	6
	J. Emergency Stop Switch	7
	K. Engine Hour Meter	7
	L. Alarm Systems	7
	M. Instrument Maintenance	7
CONTROL SYSTEMS		1
F - 1	GENERAL	1
F - 2	CONTROL OPERATION	1
	A. Carbureted Engines	1
	B. Fuel Injected Engines (EFI)	2
F - 3	NEUTRAL SAFETY SWITCH	2
F - 4	CONTROL SYSTEM MAINTENANCE	2
STEERING SYSTEMS		1
G - 1	GENERAL	1
	A. Rotary Steering	1
	B. Tilt Steering	1
	C. Power Steering	1
G - 2	PROPELLER TORQUE	2
G - 3	STEERING SYSTEM MAINTENANCE	2
	A. General Maintenance	2
	B. Rotary System Maintenance	2
	C. Winter Storage	3

ELECTRICAL SYSTEMS	1
H - 1 GENERAL	1
H - 2 BATTERY SYSTEM	1
A. Single Battery System	1
B. Dual Battery w/ Switch - Optional	1
C. Battery Switch Operation	2
H - 3 12 VOLT ELECTRICAL EQUIPMENT	3
A. Helm Equipment	3
B. Installation of Additional 12 Volt Equipment	3
C. Interior Equipment	4
H - 4 ELECTRICAL SYSTEM MAINTENANCE	4
A. Battery Maintenance	4
B. Electrical Wiring Maintenance	4
H - 5 STRAY CURRENT CORROSION	5
A. General	5
B. Galvanic Corrosion	5
C. Corrosion Prevention	6
FUEL SYSTEMS	1
I - 1 GASOLINE FUEL SYSTEMS	1
A. System Testing	1
B. Fuel Fills	1
C. Anti-Syphon Valves	2
D. Fuel Gauge	2
E. Fuel Senders	2
F. Fuel Filters	3
G. Use and Maintenance	3
I - 2 FUEL STANDARDS	3
A. Problems With Alcohol in Gasoline	3
B. Recommendations	4
I - 3 FUELING INSTRUCTIONS	4
WASTE AND WATER SYSTEMS	1
J - 1 GENERAL	1
J - 2 DISINFECTING THE WATER SYSTEM	1
J - 3 FRESH WATER SYSTEM	2
A. Integrated Sink - 214 & 234 Funships™	2
B. Refreshment Center - 264 Funship™	2
C. Forward & Aft Showers (Washdowns)	3
J - 4 HEADS	3
A. Funship™ Enclosed Heads	3
B. Pump Out Option	3
J - 5 SYSTEM MAINTENANCE	4
A. Clean Vents and Screens	4
B. Winterizing the Water System	4

VENTILATION AND DRAINAGE SYSTEMS	1
K - 1 ENGINE COMPARTMENT VENTILATION	1
A. Gravity Ventilation System	1
B. Forced Air Ventilation	1
C. Engine Ventilation System Maintenance	1
K - 2 HULL DRAINAGE SYSTEMS	1
A. Transom Drain	1
B. Bilge Pumps	1
C. Liner Drains	2
D. Bilge Compartment Drainage	2
INTERIOR EQUIPMENT	1
L - 1 INTEGRATED SINK - 214 FUNSHIP™	1
L - 2 INTEGRATED SINK & COOLER - 234 FUNSHIP™	1
L - 3 BUILT-IN ICE CHESTS	1
L - 4 REFRESHMENT CENTER - 264 FUNSHIP™	2
L - 5 HEADS	2
L - 6 STEREO	2
L - 7 BURLWOOD HELM ENHANCEMENTS	2
L - 8 ANCHOR/LADDER STORAGE	2
L - 9 IN-FLOOR STORAGE LOCKER	2
L - 10 BOW STORAGE	3
L - 11 BOW FILL-IN CUSHIONS	3
L - 12 STERN SEAT STORAGE	3
L - 13 STARBOARD CONSOLE STORAGE LOCKER	3
L - 14 SWIM PLATFORM - LADDER	3
L - 15 TRANSOM WALK-THRU BACKREST DOOR	4
L - 16 WALK-THRU DOORS	4
EXTERIOR EQUIPMENT	1
M - 1 RAILS & DECK HARDWARE	1
A. Rails	1
B. Cleats	1
C. Transom Ski Tow	1
D. Anchor/Ladder Locker	1
E. Maintenance	1
M - 2 WINDSHIELDS	2
M - 3 EXTENDED SWIM PLATFORM - LADDER	2
M - 4 TRANSOM WALK-THRU BACKREST DOOR	2
M - 5 ANCHOR & ANCHORING	3
M - 6 DEPTHSONDER	4
M - 7 TRANSOM STORAGE	4
UPHOLSTERY	1
N - 1 EXTERIOR SEATING	1
A. Cockpit Tables	1
B. Bow Table - Optional	1
C. Bow Seating	1
D. Bucket Seats	2

	E.	U-Shaped Lounger Seating	3
	F.	Motorhood (Engine Hatch)	3
N - 2		EXTERIOR UPHOLSTERY CARE	4
N - 3		REPLACEMENT UPHOLSTERY	5
N - 4		CARPET CARE	5
	A.	Interior and Exterior Carpet	5
	B.	Cleaning and Maintenance	5
	C.	Stain Removal Testing	5
	D.	Stain Removal Procedures	5
WEATHER COVERS			1
O - 1		GENERAL INFORMATION	1
	A.	Bimini Top (Aft/Main)	1
	B.	Forward Bimini Canvas (234 & 264 Funships™)	2
	C.	Camper Canvas	2
	D.	Forward Cover	3
	E.	Cockpit Cover	3
	F.	Mooring Cover	3
O - 2		TRAILERING	3
O - 3		WINTER STORAGE	4
O - 4		CARE & MAINTENANCE	4
O - 5		CARBON MONOXIDE	5
FIBERGLASS AND HULL INFORMATION			1
P - 1		HULL DESIGN INFORMATION	1
P - 2		FIBERGLASS CONSTRUCTION	1
P - 3		EQUIPMENT INSTALLATION	1
P - 4		FIBERGLASS CARE & MAINTENANCE	1
	A.	General Maintenance	2
	B.	Weathering Effects on Gel Coat	2
	C.	Stains	3
P - 5		FIBERGLASS REPAIRS	3
	A.	Scratches	3
	B.	Gouges & Cracks	4
	C.	Osmotic Blistering	4
P - 6		ANTIFOULING PAINT	5
P - 7		HULL SUPPORT	5
WOODWORK AND COMPOSITES			1
Q - 1		HIGH-PRESSURE LAMINATE CARE	1
Q - 2		STAR BOARD	1
Q - 3		BURLWOOD MAHOGANY ENHANCEMENTS	1
Q - 4		CORIAN® MATERIAL	1
Q - 5		LAMINATED FIBERGLASS	1
GENERAL MAINTENANCE			1
R - 1		WINTERIZATION	1
	A.	Prior to Lifting for Winter Lay-up	1
	B.	After Lifting	1
	C.	Prior to Winter Storage	2

R - 2	ENGINE FLUSH OUT	2
R - 3	GENERAL MAINTENANCE SCHEDULE	3-5
TRAILERS		1
S - 1	GENERAL TRAILER INFORMATION	1
	A. Regulations	1
	B. Load Carrying Capacity	1
	C. Hitches	2
S - 2	TRAILER COMPONENTS	2
	A. Bunk Supports	2
	B. Tongue	2
	C. Swivel Jack	3
	D. Coupling Assembly	4
	E. Surge Disc Brakes	4
	F. Winch	5
	G. Tires & Wheels	6
	H. Spare Tire Carrier	6
	I. Lights	7
	J. Tie-downs	7
S - 3	OPERATION	8
	A. Hitching Trailers	8
	B. Backing Up With Surge Disc Brakes	9
S - 4	TRAILERING	10
	A. Checklist	10
	B. Tactics	10
S - 5	MAINTENANCE	11
	A. Care of Exterior Finish	11
	B. Bunks	11
	C. Swivel Jack	11
	D. Brake Actuator & Coupling Assembly	11
	E. Winch	11
	F. Lights	11
	G. Tie-downs	12
	H. Wheels	12
	I. Brakes	12
	J. Bearings	12
S - 6	AXLE INSPECTION & REPAIRS	12
	A. Removal of Hub	13
	B. Bearing/Seal Inspection and Replacement	13
	C. Hub Reinstallation	13
PRELAUNCH AND UNDERWAY		1
T - 1	LAUNCH AND CRUISE CHECKLIST	1
T - 2	FUELING	2
	A. Recommendations	2
	B. Preliminary Guidelines	2
	C. Pumping Fuel	2
	D. After Fueling	2
T - 3	LOADING PASSENGERS AND GEAR	3

T - 4	STARTING PROCEDURES	4
	A. Preliminary Checks	4
	B. Starting	4
T - 5	MANEUVERING	4
	A. Leaving the Dock	5
	B. Stopping	5
T - 6	ACCELERATION	5
T - 7	TRIMMING YOUR BOAT	6
	A. Tilt/Trim Control Switches	6
T - 8	NAVIGATION LIGHTS	6
T - 9	HAZARDOUS CONDITIONS	7
	A. Storms	7
	B. Fog	7
	C. Running Aground	8
	D. Warning Markers	8
T - 10	REACTING TO EMERGENCIES	8
	A. Flooding	8
	B. Capsizing and Man Overboard	8
	C. Capsizing	8
	D. Man Overboard	8
	E. Collision	9
	F. Fire	9
	G. Medical Emergency	10
	H. Propulsion Failure	10
	I. Control Failure	10
	J. Steering Failure	10
	K. Additional Underway Information	10
T - 11	RETURNING TO SHORE	10
	A. Docking	10
	B. Mooring	11
	GLOSSARY	1-7
	FLOAT PLAN	1
	FUEL LOG	1-3
	SERVICE LOG	1-3
	SERVICE INFORMATION	1
	ELECTRICAL SCHEMATICS	1-7

OPERATION

A - 1 GENERAL

Before starting the boat, become familiar with all of the various systems and related operations. Be sure all necessary safety equipment is on-board. Know the "Rules of the Road". Have an experienced operator brief you on the general operation of your new boat. Perform a "Pre-Cruise Systems Check". This manual is a part of your boat's equipment. Always keep it on board.

A - 2 COMPONENT SYSTEMS

Before you can really enjoy your boat, a thorough understanding of its systems and their operation is essential. This manual and the associated manufacturers information are included in the owner's packet. This information is provided to enhance your knowledge of the boat. Read this information carefully.

After becoming familiar with the boat and its systems, reread this manual. Maintenance and service tips are included to help keep the boat in like-new condition.

A - 3 SAFETY EQUIPMENT

Besides the equipment installed on the boat by Four Winns, certain other equipment is required for passenger safety. A brochure listing the Federal equipment requirements is included in the owner's packet or is available through your local U.S. Coast Guard Station. Remember that these laws are for your protection and are minimum requirements. Check your local and state regulations, also. More information on safety equipment is provided in Section B.

Items like a sea anchor, working anchor, extra dock lines, flare pistol, a line permanently secured to your ring buoy, etc. could at some time save your passengers lives, or save your boat from damage.

The Coast Guard Auxiliary offers a "Courtesy Examination." This inspection will confirm the boat is equipped with all of the necessary safety equipment.

A - 4 PASSENGER SAFETY

You are responsible for the safety of your passengers as well as for their behavior while aboard. Make sure:

1. Each passenger is properly instructed in Personal Flotation Device (PFD) use and keeps one within reach in case of emergency. All non-swimmers and children should wear a PFD at all times when underway.
2. Passengers do not sit on gunwales, open decks, elevated pedestal seats or on seat backs when the boat is underway. This could cause them to be thrown overboard during a sudden maneuver.
3. At least one other person knows how to operate the boat in case of an emergency.

A - 5 "RULES OF THE ROAD"

As in driving an automobile, there are a few rules that must be known if safe boating operation is to be maintained. The Coast Guard, Coast Guard Auxiliary, Department of Natural Resources or your local boat club sponsor courses in boat handling, including "rules of the road". Such courses are strongly recommended. Books on this subject are also available from local libraries.

A - 6 LIGHTNING

When boating, it is important to be aware of the weather around you. When the weather changes for the worse, DO NOT jeopardize your safety by trying to "ride out the storm". If possible, return to safe harbor and dock your vessel immediately.

If caught in a storm, seek shelter inside the cabin and wait for the storm to pass. With open bow models, suntops and campers will provide some protection, but should not be relied on if you are able to return to shore. Exercise care when high winds are present!

**WARNING**

DO NOT swim or dangle legs or arms into the water during a lightning storm. Stay out of the water!

Lightning will seek a ground when it strikes. Avoid contact with metal parts such as bow rails, control handle, or windshield.

A - 7 DRUGS AND ALCOHOL

Please keep in mind that along with the fun of boating comes responsibility. As the owner or operator of a pleasure boat, you are obligated (morally and legally) to use good judgement while underway in providing for the safety and well-being of your passengers and other boaters around you.

A common and flagrant violation of good judgement and the law by mariners involves the use of alcohol or drugs. Each year, about half of all accidents involving fatalities involve the use of alcohol or drugs.

It is a federal offense to operate a boat while intoxicated. Criminal penalties may include the termination of operating privileges for up to one year. Many states have passed similar laws.

Alcohol or drugs have an inhibiting effect on the judgement and reaction time of the boat operator and his/her passengers. Heed the advice of experts and statisticians...DO NOT drink or use drugs when operating a boat. NEVER allow an obviously intoxicated person to take the helm.

Have fun in your Four Winns® boat but also, have the good sense to be mentally alert and physically capable of operating the boat in a safe manner.

A - 8 PRE-CRUISE SYSTEM CHECK

Before leaving the dock, the following items should be checked:

A. Before Starting The Engine

1. Check the weather forecast. Determine if the cruise planned can be made safely.

2. Be sure all necessary safety equipment is on board and operative. This includes items such as the running lights, horn, spotlight, life saving devices, etc.
3. Check the bilge water level and bilge pump operation. Check the engine and drive fluid levels. Look for other signs of potential problems. Check for the scent of fuel fumes.
4. Activate the Bilge Blower. Check the blower output.

**WARNING**

Gasoline vapors can explode resulting in injury or death. Before starting the engine, check engine compartment bilge for gasoline or vapors. Operate blower for four minutes, and verify blower operation. ALWAYS run the blower when the vessel is operating below cruising speed.

5. Ensure an adequate amount of fuel is on board.
6. Be sure you have sufficient water and other provisions on board for the cruise planned.
7. Leave a written message listing details of the planned cruise with a close friend ashore.

B. After Starting The Engine

1. Visibly check the engine to be sure there are no apparent water or oil leaks.
2. Check the gauges. Make sure the oil pressure, water temperature, voltmeter, etc. are reading normally.
3. Have a safe cruise and enjoy yourself.

A - 9 ENGINE OPERATIONAL PROCEDURES

Notice: Additional engine information is located in Section T.

A. Before Starting

1. Check the engine compartment for water, gas, and/or oil leaks of any kind. Keep the bilge in a clean condition to prevent blower and bilge pump damage, and fire hazards.
2. Check the fluid levels of the engine oil and power steering system daily. Fill oil or steering fluid as required by the indications on the dip sticks. Refer to the Table 1: "SAE Viscosity Chart" and your engine

manual included in the owner's packet. DO NOT USE MULTIGRADE OIL. Power steering and power trim use automatic transmission fluid. Check the fluid levels in the vertical drive units or transmission as often as practical.

IF THE LOWEST ANTICIPATED TEMPERATURE IS*	THE FOLLOWING SAE VISCOSITY OILS ARE RECOMMENDED
32° F (0° C) and above	SAE 30
0° F (-18° C) to 32° F (0° C)	SAE 20W-20
Below 0° F (-18° C)	SAE 10W
*Temperature range you expect to operate. Note: Use only single viscosity oils.	

Table 1: SAE Viscosity Chart

3. Start and operate the bilge blower system for at least four (4) minutes before start-up.
4. Lower the vertical outdrive units (on applicable models) making sure the water intakes are under the water.

B. Cold Engine Start (Carbureted Engines)

1. The engine may require priming prior to starting. To prime the engine, proceed as follows:
 - a. Place ignition switch in the OFF position.
 - b. Disengage shift mechanism.
 - c. Move control handle to the full throttle position; this operates accelerator pump and primes the engine.
 - d. Repeat priming, if necessary.
 - e. Return the control handle to fast idle position.
2. Turn key switch to START position and hold until engine starts. DO NOT hold in START position for more than ten seconds. In colder weather, more priming may be necessary. However, too much priming may flood engine.

If engine floods:

- Disengage shift. Move handle to full throttle position.

- Turn key switch to the START position.
- Immediately move the control handle to the idle position when the engine starts.

NOTICE

Failure to move the control handle to the idle position immediately when engine starts will allow engine to “over-rev” and engine damage could result. “Over-revving” engine after off-season storage could also damage the water pump impeller. **When starting engine for the first time after off-season storage, always idle engine for one minute to allow the water pump to prime.**

3. As soon as engine starts:
 - a. Release key to the ON or RUN position.
 - b. Move control handle to the fast idle position to warm up engine. DO NOT exceed 1000 RPM.

NOTICE

Cold engine starting procedures are different for EFI engines. Priming is not necessary. Refer to the engine owner's manual for additional information.

C. Warm Engine Starting

1. Move control handle to the neutral detent position.
2. Turn key switch to START position and hold until engine starts, but DO NOT hold in start position for more than ten seconds. If engine does not start, let go momentarily, then try again.
3. As soon as engine starts, release key to the ON or RUN position.

NOTICE

NEVER turn key to START position when engine is running.

NOTICE

Warm engine starting procedures are different for EFI engines. Refer to the engine owner's manual for additional information.

D. Shifting and Control Speed

1. Move control handle to the neutral detent (idle) position. This will engage neutral start switch and allow engine to start.

 **CAUTION**

DO NOT shift into FORWARD or REVERSE unless engine is running. Damage to the shift system could result from trying to shift without the engine running. Carefully check function of all control and engine systems before leaving the dock.

2. To go FORWARD - actuate the neutral lock mechanism and briskly move the shift handle forward. Throttle movement will begin after forward gear engagement.
3. To go in REVERSE - actuate the neutral lock mechanism and briskly move the shift handle rearward. Throttle movement will begin after reverse gear engagement.

 **WARNING**

DO NOT shift from forward to reverse when the boat is planing.

NOTICE

DO NOT shift if engine speed is above 800 RPM.

4. To go from FORWARD to REVERSE, or REVERSE to FORWARD; always pause at NEUTRAL and allow engine speed to return to idle.
5. After shifting is completed, continue to move the control handle slowly in the desired direction to increase speed.

 **WARNING**

Any time the boat is operated, be aware of changes in shift system operation. A sudden increase in shift effort at the remote control handle, or other abnormal operation, indicates a possible problem in the shift system. If this occurs, the following precautions must be taken:

- With engine running and boat securely tied to the dock, shift drive into forward and reverse to ensure there is gear engagement.
- When docking the boat, all docking maneuvers must be performed at slow speed. Pay special attention to other boaters. Passengers should be informed of potential problems and precautions taken.

If you suspect there is a problem, see your Volvo Penta/Mercruiser dealer as soon as possible for proper diagnosis and required service or adjustment. Continued operation could result in damage to the shift mechanism and loss of control.

E. Stopping Engine

1. Move control handle to the NEUTRAL position.
2. Turn ignition key to the OFF position.

NOTICE

DO NOT stop engine at speeds above idle or "speed up" engine while turning off ignition. Engine damage could result.

A - 10 GROUNDING AND TOWING

 **WARNING**

If the boat should become disabled, or if assisting another craft that is disabled, great care must be taken. The stress applied to a boat during towing may become excessive. Excessive stress can damage the structure of the boat and create a safety hazard for those aboard.

Four Winns® boats are not designed nor intended to be used as a towing vessel. The mooring cleats on Four Winns® boats are not designed or intended to be used for towing purposes. These cleats are specifically designed as mooring cleats for securing the boat to a dock, pier, etc. DO NOT use these fittings for towing or attempting to free a grounded vessel.

Freeing a grounded vessel or towing a boat that is disabled requires specialized equipment and knowledge. Line failure and structural damage caused by improper towing have resulted in fatal injuries. Because of this, Four Winns strongly suggests that these activities be left to those who have the equipment and knowledge such as the U.S. Coast Guard, to safely accomplish the towing task.



CAUTION

Running aground can cause serious damage to a boat and associated underwater gear. If the boat should become grounded, distribute personal flotation devices and inspect the boat for possible damage. Thoroughly inspect the bilge area for signs of leakage. An experienced service facility should check the hull and underwater gear at the first opportunity. DO NOT continue to use the boat if the condition of the hull or underwater equipment is questionable.

If towing or being towed is absolutely necessary, use the strongest lines available, and attach them to the bow eyes or stern eyes only. Have all passengers slip on life jackets and take a seat in the cabin or other protected area.



WARNING

Lines can snap or other hardware can be loosened or broken while towing. Under certain conditions, this can cause severe injury or fatality.

A - 11 BOATING EDUCATION

A. Boating Courses

Boating education classes are offered throughout the country. The United States Coast Guard Auxiliary offers free courses on different topics usually during the off-season. The most popular course is the "Boating Skills & Seamanship Course," and information can be obtained by calling 1-800-336-BOAT.

The United States Power Squadron also offers free courses ranging from basic seamanship to celestial navigation. For information, contact your local Power Squadron, or write: U.S.P.S., P.O. Box 30423, Raleigh, NC 27622.

The Red Cross offers power boating and canoeing classes. Contact: Director of Water Safety, American National Red Cross, 17th & D Streets N.W., Washington, DC 20006.

The Canadian Power and Sail Squadron offers seamanship courses. Information can be obtained by calling 1-800-268-3579 (Canada only).

B. Boating Manuals or Literature

A good source of information is the U.S. Coast Guard's home study book called "The Skipper's Course". This book may be purchased through: Superintendent of Documents, U.S. Government Printing Office, Washington, DC 20402, Stock # 050-012-00159-6.

Another good source of boating information is Chapman's "Piloting, Seamanship and Small Boat Handling". Also, check the local library or bookstore for additional information on boating.

C. Charts and Maps

U.S. nautical charts are sold throughout the country at Governmental Printing Office stores and other agents. A chart catalog is available by writing to: National Oceanic and Atmospheric Administration, National Ocean Survey, Rockville, MD 20852.

In addition, many federal agencies publish recreational maps, including the U.S. Army Corp of Engineers, the Forest Service, the National Park Service, and the Tennessee Valley Authority.

Addresses of all state boating agencies are listed in "A Boater's Guide". For a free copy, write to: National Marine Manufacturers Association, 401 N. Michigan Avenue, Chicago, IL 60611.

D. Laws and Regulations

The U.S. Coast Guard is the authority of the waterways; they are there to help the boating public. State boating regulations are enforced by local authorities. You are subject to marine traffic laws and "Rules of the Road" for both federal and state waterways; you must stop if signaled to do so by enforcement officers, and permit to be boarded if asked.

There are many pamphlets, prepared by the Coast Guard, available to you. These pamphlets explain "Rules of the Road," signal lights, buoys, safety, international and inland regulations and other information which goes beyond the scope of this manual. For more information contact your local U.S. Coast Guard Unit or call the Coast Guard Boating Safety Hotline at 1-800-368-5647.

A - 12 BOAT OWNER REGISTRATION

Federal and state laws require that every boat equipped with propulsion machinery of any type must be registered in the primary state of usage. Registration numbers and validation stickers must be displayed on the boat according to regulations. In most states, this means registration with the designated state agency. In a few jurisdictions, the Coast Guard retains registration authority. Your dealer will either supply registration forms or tell you where they may be obtained. The registration agency will issue you a certificate that must be carried on board when the boat is in use. Some states require additional registration when an out of state boat is used within their boundaries.

Your boat has a hull identification number on the starboard side of the hull. Figure A1 shows a typical identification number. Use this hull identification number for registration and to identify your boat for warranty service.

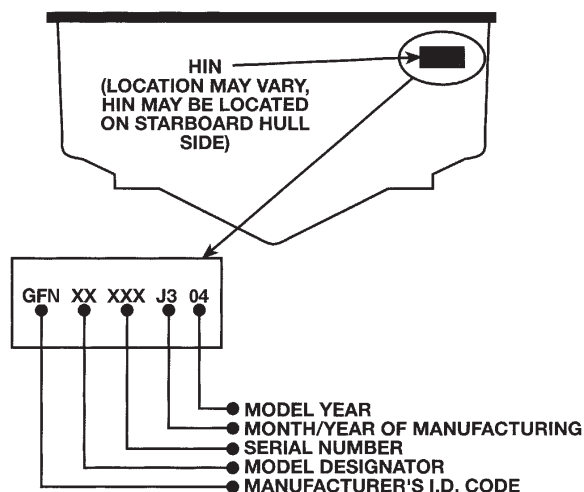

Figure A1: HIN

A - 13 INSURANCE

In most states, the boat owner is legally responsible for damages or injuries he or she causes, even if someone else is operating the boat at the time of the accident. Common sense dictates that you carry adequate personal liability and property damage insurance on your boat, just as you would on an automobile. You should also protect your investment by insuring your boat against physical damage or theft.

A - 14 ACCIDENT REPORTING

The operator of the boat is responsible for filing a report with the appropriate authorities. In general, reports are necessary for accidents involving loss of life, injury, or damage over \$500. In the case of accidents with reportable injuries or death, a formal report is required within 48 hours. If only property damage is involved, a report must be made within ten days. The 1971 Boating Safety Act may impose a \$1,000 civil fine for people who fail to submit a boating accident report. Ask your insurance agent for more information.

If you see a distress signal, you must assume it is a real emergency and render assistance immediately. The master or person in charge of a boat is obligated by law to provide assistance to any individual in danger at sea. However, you should not put your boat or crew in a dangerous situation which exceeds your capabilities or those of your boat. The 1971 Boating Safety Act grants protection to a Good Samaritan boater offering good faith assistance, and absolves a boater from any civil liability arising from assistance given.

A - 15 DISCHARGE OF OIL

The Federal Water Pollution Control Act prohibits the discharge of oil waste into or upon the navigable waters of the United States or the waters of the contiguous zone if such discharge causes a film or sheen upon or a discoloration of the surface of the water or causes a sludge or emulsion beneath the surface of the water. Violators are subject to a penalty of \$5,000.

A - 16 DISPOSAL OF PLASTICS & OTHER GARBAGE

Plastic refuse dumped in the water can kill fish and marine wildlife and can foul boat propellers and cooling water intakes. Other forms of waterborne garbage can litter our beaches and make people sick. U.S. Coast Guard and most state regulations prohibit the dumping of plastic refuse or other garbage mixed with plastic into the water anywhere, and restrict the dumping of other forms of garbage within specified distances from shore.

A - 17 MARPOL TREATY

Boats 26 feet or longer must display a sign stating the disposal regulations of the Federal Water Pollution Control Act. The U.S. Coast Guard has issued these regulations to implement Annex V of the International Convention for the Prevention of Pollution from Ships, 1973, commonly known as Annex V of the MARPOL (Marine Pollution) Treaty 73/78. They apply to all U.S. boats wherever they operate (except waters under the exclusive jurisdiction of a State) and foreign boats operating in U.S. waters out to and including the Exclusive Economic Zone (200 miles). It is important to know these regulations and adhere to them.

The regulations require U.S. recreational boaters, if your boat is 26 feet or more in length, to affix one or more USCG Trash Dumping Restrictions placards to your boat. The placard warns against the discharge of plastic and other forms of garbage within the navigable waters of the United States and specify discharge restrictions beyond the territorial sea. (The territorial sea generally ends three nautical miles from the seashore.) In addition, the placard must contain the warning that a person who violates these requirements is liable to civil (\$25,000) and criminal (Imprisonment) penalties. The placard also must note that State and local regulations may further restrict the disposal of garbage.

Operators shall display one or more placards in a prominent location and in sufficient numbers so they can be observed and read by crew and passengers. These locations might include embarkation points, food service areas, galleys, garbage handling spaces and common deck spaces frequented by crew and passengers. We recommend that these placards may be purchased from local marinas, boat dealerships and marine equipment suppliers. A special placard is available for boats operating on the Great Lakes.

IMPORTANT: It is illegal to discharge waste from your marine sanitary device (toilet) into the water in most areas. It is your responsibility to be aware of and adhere to all local laws concerning waste discharge. Consult with the Coast Guard, local marina or your dealer for additional information.

NOTE: Some states and localities have legal limits on speed, noise and trailer specifications. It is your responsibility to be aware of these laws and limits and to insure that your boat (and trailer) comply. Consult with your local Marine Patrol or local Coast Guard office.

BOATING SAFETY

B - 1 GENERAL

As the owner/operator of the boat, you are responsible for assuring that all required safety equipment is aboard. You should also consider supplying additional equipment as needed for your safety and that of your passengers. Check state and local regulations and call the U.S. Coast Guard Boating Safety Hotline at 1-800-368-5647 for information about required safety equipment.

A. Required Safety Equipment

Most of the safety equipment required by federal regulations is provided as standard equipment. Personal Floatation Devices (life jackets) must fit the person wearing it. If local regulations require additional equipment, it must be approved by the U.S. Coast Guard (USCG). Minimum requirements include the following:

- Personal Floatation Devices
- Visual Distress Signal
- Bell or Whistle
- Fire Extinguisher
- Navigation Lights

B. Personal Floatation Devices (PFD's)

Federal regulations require that you have at least one Coast Guard approved personal floatation device (PFD) for each person in a recreational boat. You should not use your boat unless all PFDs are in serviceable condition, readily accessible, legibly marked with the Coast Guard approval number, of an appropriate size (within the weight range and chest size marked on the PFD) for each person aboard.

A PFD provides buoyancy to help keep your head above the water and to help you remain in a satisfactory position while in the water. Body weight and age should be considered when selecting a PFD. The buoyancy provided by the PFD should support your weight in water.

The size of the PFD should be appropriate for the wearer. Body weight or chest size are common methods used to size PFDs. It is your responsibility to ensure that you have the proper number and types of PFD's on board and that your passengers know where and how to use them.

C. PFD Types

Five types of PFDs have been approved by the U.S. Coast Guard. The PFDs are described as follows:

PFD Type 1, Wearable (Figure B1) has the greatest required buoyancy. Its design allows for turning most unconscious persons in the water from face down position to a vertical or slightly backward, face-up position. It can greatly increase the chances of survival. Type 1 is most effective for all waters, especially offshore when rescue may be delayed. It is also the most effective in rough waters.



Figure B1: Type I, Wearable

PFD Type II, Wearable (Figure B2) turns its wearer in the same way as Type I, but not as effectively. The Type II does not turn as many persons under the same conditions as a Type I. You may prefer to use this PFD where there is a probability of quick rescue such as in areas where other people are commonly involved in water activities.



Figure B2: Type II, Wearable

PFD Type III, Wearable (Figure B3) allows the wearer to place themselves in a vertical or slightly backward position. It does not turn the wearer. It maintains the wearer in a vertical or slightly backward position and has no tendency to turn the wearer face down. It has the same buoyancy as a Type II PFD and may be appropriate in areas where other people are commonly involved in water activities.



Figure B3: Type III, Wearable

PFD Type IV, Throwable (Figure B4) is required in addition to the PFDs previously discussed. The most common Type IV PFD is a buoyant cushion or ring buoy. It is designed to be thrown to a person in the water, grasped and held by the user until he or she is rescued. A Type IV PFD should always be in serviceable condition and immediately available for use. Grasping this PFD may be difficult if the rescue is delayed or if the user is overcome by hypothermia (loss of body heat).



Figure B4: Type IV, Throwable

PFD Type V, Wearable (Figure B5) when inflated, it provides buoyancy equivalent to Type I, II, or III PFDs. When it is deflated, however, it may not support some people.



Figure B5: Type V, Wearable

D. PFD Pointers

The purpose of a PFD is to help save your life. If you want it to support you when you are in the water, it needs to fit, float, and be in good condition.

1. Try the PFD on and adjust it until it fits comfortably in and out of the water. Mark your PFD if you are the only wearer.

2. To make sure the PFD works, wear it in the water. This will show you how it works and give you confidence when you use it.
3. Teach children how to put a PFD on and allow them to try it in the water. That way, they know what the PFD is for and how it works. They will feel more comfortable with it if they suddenly find themselves in the water.
4. If the PFD is wet, allow it to dry thoroughly before storing it. Do not dry it in front of a radiator or heater. Store it in a well ventilated area.
5. Keep PFDs away from sharp objects which can tear the fabric or puncture the floatation pads.
6. For their own safety and the safety of others, all nonswimmers, poor swimmers, and small children should wear PFD's at all times, whether the boat is stationary or moving.
7. Check the PFD frequently to make sure that it is not torn, that floatation pads have no leaks, and that all seams and joints are securely sewn.
8. If a PFD contains kapok, the kapok fibers may become waterlogged and lose their buoyancy after the vinyl inserts are punctured. If the kapok becomes hard or if it is soaked with water, replace it. It may not work when you need it.

E. Emergency Stop Switch

This safety device automatically stops the engine if the lanyard is attached to the operator and the operator falls from his work station. Refer to the engine manual for detailed information about using this switch.

The emergency stop switch (Figure B6) incorporates a shutoff switch, switch clip, lanyard, and lanyard clip. The lanyard clip must be securely attached to the operator's PFD, clothing, arm, or leg. Be sure to attach the lanyard to a place where it is free of obstructions and to something that will move with the operator if he or she leaves the helm station. If the engine shuts down because this switch was activated, the clip may have to be reinstalled on the interrupter switch before the engine can be started.

WARNING

Keep emergency stop switch lanyard free from obstructions that could interfere with its operation. Do not modify or remove emergency stop switch or bypass its safety features. The proper use of the emergency stop switch will prevent a runaway boat situation which can cause severe personal injury or death.

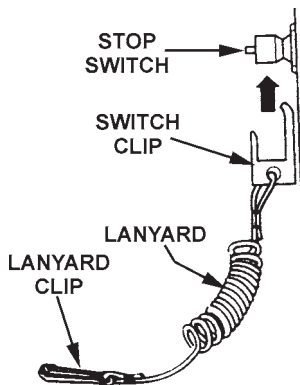

Figure B6: Emergency Stop Switch

F. Fire Extinguisher

As the owner/operator of the boat, you are responsible for supplying a fire extinguisher approved by the U.S. Coast Guard.

NOTICE

As the owner/operator of the boat, you are responsible for assuring that all required safety equipment is aboard and meets the boating regulations as prescribed by both federal and local authorities in your area.

Hand-held portable extinguisher(s) should be mounted in a readily accessible location(s) away from the engine compartment. All persons aboard should know the location(s) and proper operation of the fire extinguisher(s).

WARNING

Fire!

In case of fire do not open the engine compartment. Shut down engine(s), generator(s), and blower(s). Discharge entire contents of fixed fire suppression system, if equipped. If using portable CO2 fire extinguisher continuously discharge entire contents. On European models, discharge contents through fire port.

NOTICE

Using a portable fire extinguisher with an access/fire port in the engine compartment is preferred to opening the engine compartment to fight the fire. However, using a portable extinguisher in this way provides less protection against fire than a fixed suppression system.

NOTICE

Do not test fire extinguishers by squirting small amounts of the extinguishing compound. The fire extinguisher might not work when you really need it.

The Funship™ models are considered to be Class 1 powerboats (16 to less than 26 feet). Since they have permanently installed fuel tanks, they are required to carry one (1) B-1 type hand portable fire extinguisher. If the boat is equipped with a fixed fire extinguishing system in the engine compartment, one (1) B-1 type hand portable fire extinguisher is still required.

G. Visual Distress Signal Devices

Visual distress signal devices approved by the U.S. Coast Guard are required on all recreational boats operating on coastal waters and to boats owned in the United States when they are operating on the high seas. Coastal waters include territorial seas and those waters directly connected to the Great Lakes and the territorial seas up to a point where the waters are less than two miles (3.2km) wide. Visual distress signal equipment may be of the pyrotechnic or non-pyrotechnic type. Regulations prohibit display of visual distress signals on the water under any circumstances except when assistance is required to prevent immediate or potential danger to persons on board a vessel.

The equipment must be approved by the U.S. Coast Guard, be in serviceable condition, and be stowed in a readily accessible location. Equipment having a date for serviceable life must be within the specified usage date shown. Careful selection and proper stowage of visual distress equipment is very important if young children are aboard.

DAY USE ONLY	NIGHT USE ONLY	DAY AND NIGHT USE
Three orange smoke signals (one hand held and two floating) or one orange flag with black square and disk.	One S-O-S electric distress light.	Three flares of the hand held, meteor or parachute type.

Distress Signal Table

The minimum visual distress signals required in coastal waters for a Class 1 powerboat is the following:

One orange flag with black square-and disc (daytime); and an S-O-S electric light (night-time); or three orange smoke signals, hand held or floating (daytime); or three red flares of hand held, meteor, or parachute type (daytime/night-time).

NOTICE

No single signaling device is appropriate for all purposes. Consider keeping various types of equipment on board.

H. Sound Signaling Devices

Class 1 powerboats (16 to less than 26 feet) are required to carry a hand, mouth or power operated horn or whistle. It must produce a blast of two-second duration and audible at a distance of at least one-half (1/2) mile.

The following are standard whistle signals:

- One Prolonged Blast Warning Signal
- One Short Blast Pass on my Port Side
- Two Short Blasts Pass on my Starboard Side
- Three Short Blasts Engines in Reverse
- Five or More Blasts Danger Signal

I. Navigation Lights

Navigation lights are intended to keep other vessels informed of your presence and course. If you are out on the water between sunset and sunrise, you are required to display appropriate navigation lights.

J. Additional Recommended Equipment

Four Winns recommends that you acquire additional equipment for safe, enjoyable cruising. This list, which is not all inclusive, includes items you should consider acquiring.

Basic Gear

- | | | |
|--|---------------------|---------------|
| Flashlight | Spare batteries | Tow line |
| Oar, paddle | Mooring lines | Compass |
| Dock fenders | Distress signals | First aid kit |
| Boat hook | VHF radio | EPIRB* |
| Sunscreen | Extra warm clothing | Charts |
| Second anchor & line | | |
| Dewatering device (pump or bailer) | | |
| Emergency supply of drinking water and food. | | |

*Emergency Position Indicating Radio Beacon

Tools

- | | | |
|-------------------|-----------------|-----------------|
| Spark plug wrench | Hammer | Screwdriver |
| Jackknife | Pliers | Electrical tape |
| Adjustable wrench | Lubricating oil | Prop wrench |
| Duct tape | | |

Spare Parts

- | | | |
|-----------------------|-------------|-------------|
| Extra bulbs | Spare prop | Extra fuses |
| Extra drain plug | Spark plugs | Spare wire |
| Extra prop nut/washer | | |

Gear For Extended Cruises

- | | | |
|---|-----------------|----------|
| Foul weather gear | Parallel rulers | Dividers |
| Loran or Global Positioning System navigation equipment | | |

B - 2 CARBON MONOXIDE



Carbon Monoxide!

Carbon monoxide (CO) can be harmful or fatal if inhaled. Brain damage or death can result from prolonged exposure to carbon monoxide. Keep exhaust outlets clear of blockage. Provide adequate ventilation. Open hatches, doors, windows and vents to insure adequate ventilation. Close engine compartment doors and hatches when engine or generator is running. Avoid operating the boat for extended periods of time at idle speed, and be sensitive to weather conditions that may prevent CO from dissipating into the air.

Carbon monoxide accumulation is affected by many variables (e.g., boat geometry, hatch, window and door opening, ventilation openings, proximity to other structures, swim platforms, canvas enclosures, location of exhaust outlets, vessel attitude, wind direction, vessel speed, boat systems maintenance, etc.) The technical information included in this section is to inform the boat owner of possible cause and effects of carbon monoxide exposure. This information has been reprinted with permission from the American Boat and Yacht Council's (ABYC) technical information report: "[Educational Information About Carbon Monoxide](#)". This information pertains to all gasoline powered boats manufactured by Four Winns.

NOTICE

The boat owner should be aware that other factors may contribute to carbon monoxide accumulation. The most common ones are listed in this section. If a person is exhibiting carbon monoxide-type symptoms (Refer to B-2E Symptoms), be sure to take the necessary precautions as prescribed later in this section.

NOTICE

Boats fueled by diesel have limited carbon monoxide present in the exhaust in comparison to gasoline engine exhaust. However, the boat owner should still be aware of the causes and effects of carbon monoxide which may occur in different boating situations.

A. Properties and Characteristics of Carbon Monoxide

1. Carbon monoxide is a colorless, odorless and tasteless gas. It is commonly referred to as CO.
2. Its weight is about the same as air so it cannot be expected to rise or fall like some other gases, but will distribute itself throughout the space.

NOTICE

DO NOT rely on the use of smell or sight of other gases to detect CO, because it diffuses in the air much more rapidly than easily detectable (visible and odorous) gases.

B. What Makes Carbon Monoxide

Any time a material containing carbon burns such as gasoline, natural gas, oil, propane, coal, or wood, CO is produced.

Common sources of carbon monoxide are:

1. Internal combustion engines.
2. Open flame devices such as:
 - a. Cooking ranges
 - b. Central heating plants
 - c. Space heaters
 - d. Water heaters
 - e. Fireplaces
 - f. Charcoal grills

C. How a Person is Affected by Carbon Monoxide

Carbon monoxide is absorbed by the lungs and reacts with blood hemoglobin to form carboxyhemoglobin, which reduces the oxygen carrying capacity of the blood. The result is a lack of oxygen for the tissues with the subsequent tissue death and, **if prolonged, death of the individual.**

D. Effects of Carbon Monoxide

Carbon monoxide in high concentrations can be fatal in a matter of minutes. Lower concentrations must not be ignored because the effects of exposure to CO are cumulative and can be just as lethal.

Certain health related problems and age will increase the effects of CO. People who smoke or are exposed to high concentrations of cigarette smoke, consume alcohol or have lung disorders or heart problems, are particularly susceptible to an increase in the effects from CO. However, all occupants' health should be considered. Physical exertion accelerates the rate at which the blood absorbs CO.

E. Symptoms

One or more of the following symptoms can signal the adverse effect of CO accumulation:

1. Watering and itchy eyes
2. Flushed appearance
3. Throbbing temples
4. Inattentiveness
5. Inability to think coherently
6. Ringing in the ears
7. Tightness across the chest
8. Headache
9. Drowsiness

10. Incoherence
11. Nausea
12. Dizziness
13. Fatigue
14. Vomiting
15. Collapse
16. Convulsions

NOTICE

The order of the above list is generally the sequence of appearance of symptoms. However, the order of appearance may change for different people.

NOTICE

The symptoms of Carbon monoxide poisoning may easily be mistaken for seasickness.

F. Treatment Treatment (Evaluate, Ventilate, Evacuate, Investigate, Take Corrective Action)

1. Move the person to fresh air.
2. Administer oxygen if available.
3. Contact Medical help.
4. If the victim is not breathing, perform artificial respiration per approved CPR procedures until medical help arrives and takes over.

NOTICE

Prompt action can make the difference between life and death.

5. Ventilate area.
6. Investigate source of CO and take corrective action.

G. Inspection

Look and listen for leaks in the exhaust systems of both the generator and propulsion engine(s). Look for discoloration around joints in the system (water leaks, carbon, stains, etc.).

1. Make sure all exhaust clamps are in place and secured.
2. Make sure ventilation systems work and are not obstructed or restricted.

3. Make sure gaps around the engine room plumbing and cableways and exhaust system doors, hatches, and access panels are minimized to reduce the opportunity for CO to enter the accommodation space(s).

H. Operation

Cold Start vs. Warm Start: CO production is greater while the combustion chamber surfaces and gas passages are cold versus when they are warm. A boat operator should:

1. Pay attention to ventilating the boat.
2. Orient the boat so it will allow the maximum dissipation of CO.
3. Minimize the time spent on getting underway.

 **WARNING**

The following are examples of possible situations where carbon monoxide can accumulate within your boat while docked, anchored, or underway. Become familiar with these examples and their precautions to prevent **dangerous** accidents or death.

I. Boathouses, Sea Walls and Other Boats

A boat operator should be aware that dangerous concentrations of CO can accumulate when a boat, generator or other engine operated device is operated while the boat is moored in a confined area such as:

1. Boathouses,
2. Proximity to sea walls, or
3. Proximity to other boats.

Orient the boat for maximum dissipation of the exhaust or **DO NOT** run the boat or boat equipment for extended periods under these conditions. See Figure B7.

Dangerous levels of carbon monoxide can also accumulate around the outside of the boat when the boat engine or generator is running. Do not run the engine or generator when anyone is in the water around your boat.

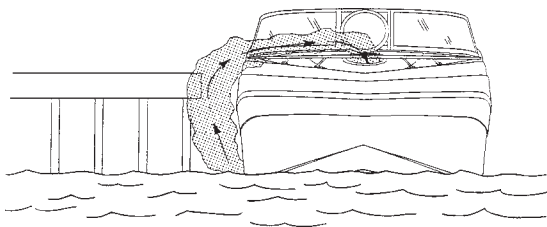

Figure B7: The effect of sea walls and other confined spaces.

A boat operator should be aware that carbon monoxide is emitted from any boat's exhaust. The operation, mooring, and anchoring in an area containing other boats may be in an atmosphere containing CO not of the operator's making. An operator likewise needs to be aware of the effect of his actions on other boats. Of prime concern is the operation of an auxiliary generator with boats moored along side each other. Be aware of the effect your exhaust may have on other vessels and be aware that the operation of other vessel's equipment may affect the carbon monoxide concentration on your vessel. See Figure B8.

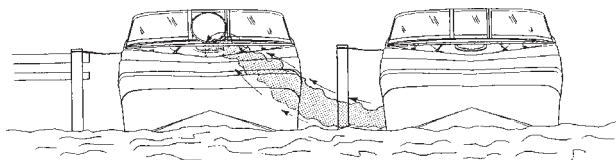

Figure B8: The effect of boats moored along side.

J. Backdrafting (Station Wagon Effect)

Backdrafting or the "station wagon effect" is caused by air movement over or around a boat creating a low pressure area of suction area around the stern which can increase CO level on the boat. Backdrafting can be affected by relative wind direction, boat speed, and boat trim angle. See Figure B9 Backdrafting - Airflows Over Boat and Behind Transom".

Under certain speed and operating conditions the low pressure area may form in other regions and permit carbon monoxide to enter the hull through openings that are not on the back of the vessel. Boat factors which may affect CO concentration:

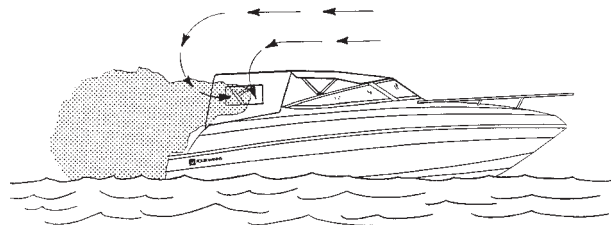

Figure B9: Backdrafting - Air flows over boat and behind transom.

1. Inefficient trim angle. See Figure B10.
2. Excessive or unequally distributed weight.

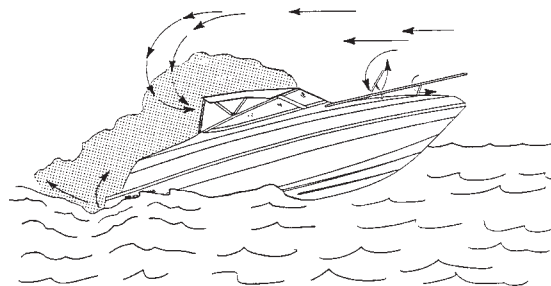

Figure B10: Inefficient trim angles.

3. Canvas Configurations - Under various conditions, adding or removing canvas may raise or lower CO levels. See Figures B9, B10 & B12.

⚠ WARNING
Exhaust Fumes!

Hull exhaust from your boat can cause excessive accumulation of poisonous carbon monoxide gas within cockpit areas when using protective weather coverings (while underway or while stationary). Provide adequate ventilation when the canvas top, side curtains and/or back (aft) curtains are in their closed protective positions.

4. Opening and closing ports, hatches, doors, and windows may raise or lower CO levels on board a boat. See Figures B11 and B12.

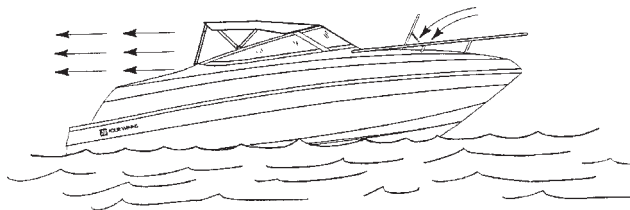

Figure B11: Desired air flow through the boat.

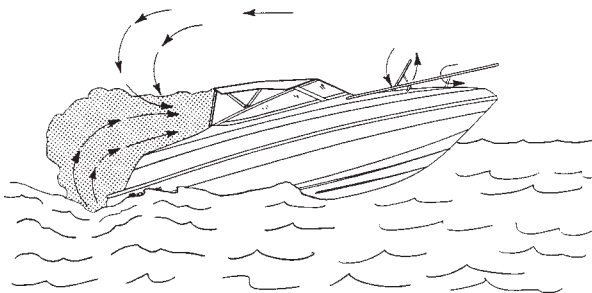

Figure B12: The effect of canvas configurations.

K. Cabin Appliances

Boats having fuel burning appliances in accommodation areas should be provided with adequate ventilation and maintained to function properly.

L. Ventilation of Accommodation Spaces

Accommodation spaces need to be ventilated to introduce fresh air into the spaces. Ventilation method; e.g. windows, hatches, doors, and blowers; used to accomplish this may, under certain conditions, bring hazardous levels of CO into the accommodation spaces. Care should be taken to be aware of all prevailing conditions when using these ventilating methods.

M. Altitude and Sea Conditions

Changes in altitude greater than 5,000 feet contribute to inefficient engine performance and may require adjustments to the ignition systems, fuel systems, or changing the propeller's size.

1. Failure to make adjustments to ignition systems, fuel systems, and propeller size may cause an increase in CO production.
2. Heavy sea conditions tend to load engines resulting in reduced performance and thereby increasing their CO production.

N. Running of Engines in Idle

Engines running in idle exhaust carbon monoxide that can accumulate near the hull of the boat. Do not stand or swim near the engine exhaust or outdrive when engines are idling or generator is running.

O. Portable Generator Sets

Gasoline powered portable generators are available in the marine market place and are not an option available through Four Winns. Portable generators will produce CO. These sets discharge their exhaust products in locations which can lead to an increase in the accumulation of carbon monoxide in the accommodation space. This equipment is not recommended for use on Four Winns® boats.

P. Maintenance - Engine Performance

Efficient engine performance is vital to minimizing CO production and decreasing hydrocarbon emissions that pollute the air and water. The following items are those considered to have the greatest effect on increased CO production:

1. Fuel Systems - Fuel that is contaminated, stale or incorrect octane number.
2. Carburetors/Injectors
 - a. Dirty or clogged flame arrester.
 - b. Malfunctioning automatic choke plate or faulty adjustment of manual choke plate.
 - c. Worn float needle valve and seat.
 - d. High float level.
 - e. Incorrect idle mixture adjustment.
 - f. Dirty or worn injectors.
3. Ignition System
 - a. Fouled or worn spark plugs.
 - b. Worn points or incorrect gap on points.
 - c. Shorted or opened circuit high tension spark plug cables.

- d. Incorrect ignition timing.
- 4. General
 - a. Worn piston rings and valves.
 - b. Engine temperature - Cold running engines increase CO production. Engine cooling water system design and selection of thermostat(s) are primary considerations affecting engine operating temperature. Generally, an engine produces less CO if it operates at a relatively high temperature within manufacturer's specifications.
 - c. Exhaust Back-Pressure - Certain alterations to the exhaust system may increase engine exhaust back pressure and CO production.
 - d. Restricted engine room or compartment ventilation.

Q. Maintenance - External Conditions

External conditions that contribute to inefficient engine performance are:

- 1. Fouled hull bottom.
- 2. Damaged and fouled running gear (propeller and trim tabs).
- 3. Incorrect selection of propeller size.

B - 3 SAFE BOATING PRACTICES

NOTICE

YOU are responsible for your own safety, the safety of your passengers, and the safety of fellow boaters.

A. Drugs and Alcohol

 **WARNING**

Alcohol consumption and boating do not mix! Operating under the influence endangers the lives of your passengers and other boaters. Federal laws prohibit operating a boat under the influence of alcohol or drugs.

Do not use drugs or drink alcohol while operating a boat. Like driving a car, driving a boat requires sober, attentive care. Operating a boat while intoxicated or under the influence of drugs is not only dangerous, but it is also a Federal offense carrying a significant penalty. These laws are vigorously enforced. The use of drugs and alcohol, singly or in combination, decreases reaction time, impedes judgement, impairs vision, and inhibits your ability to operate a boat.

B. Safe Operation

Safe operation means that you do not misuse your boat nor do you allow your passengers to do so. Safe operation means using good judgement at all times. It includes, without limitation, the following actions:

- Observe all safety signs and warnings both inside the boat and in the immediate boating area.
- Become familiar with, and adhere to, the "Rules of the Road".
- Maintain boat speed at or below the legal limits. Avoid excessive speed or speeds not appropriate for operating conditions.
- Be sure at least one other passenger is familiar with the operation and the safety aspects of the boat in case of an emergency, and knows how to use and locate all safety equipment.
- Load the boat within the limits listed on the capacity plate. Balance loads bow and stern and port to starboard. Passengers are to sit only on seats, not seat backs, gunwales, engine cover, or any other unsafe locations.
- Do not use the boat in bad weather or sea conditions beyond the skill or experience of the operator or the comfortable capability of the boat or passengers.
- Make sure the passengers and gear do not obstruct the operator's view or impede his ability to move.
- Do not exceed the maximum engine power rating stated on the certification plate located inside the boat.

C. Passenger Safety

Before getting underway, show all passengers where emergency and safety equipment is stowed, and explain how to use it. Everyone aboard should wear rubber-soled shoes which resist slipping on wet surfaces. While underway, passengers should remain seated inside the deck rails and gates. Do not allow passengers to drag their feet or hands in the water. Always use handholds and other safety hardware to prevent falls. All nonswimmers, poor swimmers and small children should wear PFDs at all times.

D. Propeller



WARNING
Personal Injury!

Do not allow anyone near a propeller, even when the engine is off. Propeller blades can be sharp and continue to turn even after the engine is shut off. Do not allow anyone near the propeller when the throttle is in neutral position. Accidentally engaging the shift can result in a serious injury or death. (See actual ladder warning labels and helm boarding ladder warning label below.)



DANGER

Never approach or use ladder when motor is running. Severe injury or death will result from contact with rotating propeller.

Ladder Warning Label



DANGER

Shut off motor when near swimmers. Severe injury or death will result from contact with rotating propeller.

Helm Boarding Ladder Warning Label



WARNING

When pulling skiers do not turn on the engine until you are at least a boat length away from the person in the water. When approaching a downed skier, turn off the engine at least one boat length away before reaching the skier in the water.

E. First Aid

As a boater, you should be familiar with the basic first aid procedures that may be needed while you are out far

from help. Fish hook accidents or minor cuts and abrasions may be the most serious mishaps on board a boat but you should also learn the proper procedures and be ready to deal with the truly serious problems like mouth-to-mouth resuscitation, excessive bleeding, hypothermia, and burns. First aid literature and courses are available through most Red Cross chapters.

F. Operation By Minors

Minors should always be supervised by an adult whenever operating a boat. Many states have laws regarding the minimum age and licensing requirements of minors. Be sure to check local laws or contact the state boating authorities for information.

G. "Rules of the Road"

As a responsible boater, you must comply with the "Rules of the Road," the marine traffic laws enforced by the U.S. Coast Guard. Navigating a boat is much the same as driving an automobile. Operating either one responsibly means complying with a set of rules intended to prevent accidents. Just as you assume other car drivers know what they are doing, other boaters assume you know what you are doing. Information regarding navigational rules and the "Rules of the Road" are discussed in further detail in C-1 & C-2 of the next section.

H. Voluntary Inspections

State boating officials in many states or the U.S. Coast Guard Auxiliaries offer courtesy inspections to check out your craft. They will check for compliance with safety standards and required safety equipment. You may voluntarily consent to one of these inspections, and you are allowed to make corrections without prosecution. Check with the appropriate state agency or the Coast Guard Auxiliary for details.

I. Safe Boating Courses

The local U.S. Coast Guard Auxiliary and the U.S. Power Squadrons offer comprehensive safe boating classes several times a year. You may contact the Boat/U.S. Foundation at 1-800-336-BOAT (2628) or, in Virginia, 1-800-245-BOAT (2628) for a course scheduled in your area. Also contact the U.S. Coast Guard Auxiliary or Power Squadron Flotilla for the time and place of their next scheduled class.

B - 4 WATER SPORTS



WARNING

Personal Injury!

Four Winns® boats are not designed for and should not be used for pulling parasails, kites, gliders or any device which can become airborne. Use boat only for appropriate water sports. (See Preface for actual warning label.)

Water skiing, kneeboarding, or riding a towed, inflatable apparatus are some of the more popular water sports. Taking part in any water sport requires increased safety awareness by the participant and the boat operator. If you have never pulled someone behind your boat before, it is a good idea to spend some hours as an observer, working with and learning from an experienced driver. It is also important to be aware of the skill and experience of the person being pulled. Always have a second person on board to observe the person in the water so the driver can concentrate on operating the boat.

A. Water Sport Guidelines

Everyone participating in a water sport should observe these guidelines:

1. Allow only capable swimmers to take part in any water sport.
2. Always wear a personal flotation device (PFD) approved by the U.S. Coast Guard. Wearing a properly designed PFD helps a stunned or unconscious person stay afloat.
3. Be considerate of others you share the water with.
4. Give immediate attention to a person who has fallen. He or she is vulnerable in the water alone and may not be seen by other boaters.
5. Approach a person in the water from the lee side (opposite the direction of the wind). **Turn off the motor at least a boat length from the person.**
6. Turn engine off and anchor before swimming.
7. Always participate in water sports in safe areas. Stay away from other boats, beaches, restricted areas, swimmers and heavily traveled waterways.

8. Swim only in areas designated as safe for swimming. These are usually marked with a swim area buoy (see Figure B13). Do not swim alone or at night.



Figure B13: Swim Area Buoy



WARNING

Rotating Propeller!

Rotating propeller can cut or sever causing serious injury or death. Shut engine off and remove ignition key when anyone is swimming nearby. (See Section B-3D.)

9. Do not allow anyone near the propeller(s), even when the engine is off. Propeller blades are sharp and can continue to turn even after the engine is off. Stay at least 150 feet away from areas marked by diver down float. See Figure B14.



Figure B14: Diver Down Float

10. Do not drive the boat directly behind a water skier. At 25 miles per hour, the boat will overtake a fallen skier who was 200 feet in front in about 5 seconds.

B. Water Skiing

The popular sport of water skiing has brought a special set of safety precautions to observe in boating. The following guides help prevent accidents while water skiing.

1. Water ski only in safe areas, away from other boats and swimmers, out of channels, and in water free of underwater obstructions.

2. Allow no one who can not swim to water ski. Skiers must wear a USCG approved floatation device. A Type III water-ski vest is an approved and practical PFD.
3. Have a second person aboard to observe the skier and inform the driver about the skier's hand signals (Figure B15). The driver must give full attention to operating the boat and the waters ahead.
4. Give immediate attention to a fallen skier. Be careful not to swamp the boat while taking the skier on board.
5. Always participate in water sports in safe areas. Stay away from other boats, beaches, swimmers, and heavily traveled waterways.
6. Be considerate of others you share the water with.
7. Give immediate attention to a person who has fallen. He or she is vulnerable in the water alone and may not be seen by other boaters.
8. Approach a person in the water from the lee side (opposite the direction of the wind). Stop the motor at least a boat length from the person.
9. Turn off engine and anchor your boat before swimming.

**WARNING****Rotating Propeller!**

Rotating propeller can cut or sever causing serious injury or death. Switch engine off before skiers enter the water and before taking skiers aboard. **Do not leave engine running in neutral.** Accidentally engaging shift can seriously injure skier.

10. Do not water ski between sunset and sunrise. It is illegal in most states.

For more information about water skiing, please contact the American Water Ski Association, 799 Overlook Drive, Winter Haven, FL. 33884 or call 1-800-533-2972.

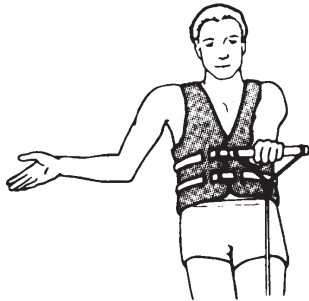

FASTER—
Palm of one hand pointing upward.



SLOWER—
Palm pointing down.



SPEED OK—
Arm upraised with thumb and finger joined to form circle.

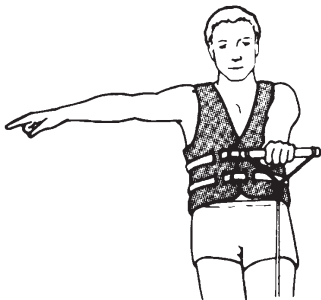

RIGHT TURN—
Arm outstretched pointing to the right.

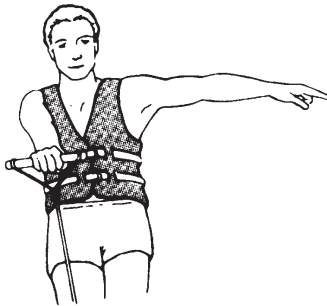

LEFT TURN—
Arm outstretched pointing to the left.



RETURN TO DROP-OFF AREA —
Arm at 45 degree from body pointing down to water and swinging.



CUT MOTOR—
Finger drawn across throat.

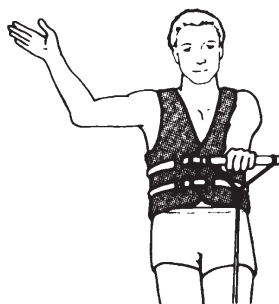

STOP—
Hand up, palm forward, policeman style.



SKIER OK. AFTER THE FALL—
Hands clenched together overhead.

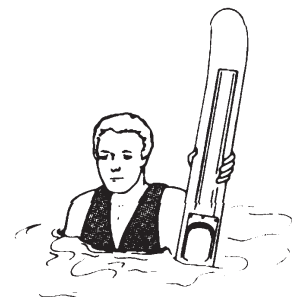

PICK ME UP OR FALLEN SKIER, WATCH OUT—
One ski extended vertically out of water.

Figure B15: Skiing Signals

BASIC SEAMANSHIP

C - 1 GENERAL

Basic rules of seamanship, general information about navigational aids, and sources for additional reading and boater education are presented in this portion of your owner's manual.

A. Boating Regulations

The U.S. Coast Guard is the authority of the waterways. State boating regulations are enforced by local authorities. Your boat is subject to the marine traffic laws known as "Rules of the Road," which are enforced by the U.S. Coast Guard. You are subject to marine traffic laws and "Rules of the Road" for both federal and state waterways; you must stop if signaled to do so by enforcement officers, and permit them to board if asked. The "Rules of the Road" can be obtained from the local U.S. Coast Guard Unit or the United States Coast Guard Headquarters by calling (202) 512-1800 or faxing your request to (202) 512-2250, and asking for the publication titled "Navigational Rules, International-Inland.

Many pamphlets prepared by the Coast Guard are available. They explain signal lights, buoys, safety, international and inland regulations and other information which goes beyond the scope of this manual. "Aids to Navigation" (U.S. Coast Guard pamphlet #123) explains the significance of various lights and buoys. Because of proposed alterations to buoys and markers, contact the U.S. Coast Guard to stay informed of changes. Other pamphlets, including the "Boating Safety Training Manual" and "Federal Requirements For Recreational Boats," are also available from the U.S. Coast Guard Headquarters.

NOTICE

The spoken word "MAYDAY" is the international signal for distress. "MAYDAY" should **NEVER** be used unless there is grave or imminent danger, and you are in need of immediate assistance.

B. Rules of Seamanship

1. Right-of-way

In general, boats with less maneuverability have right-of-way over a more agile craft. You must stay out of the way of the following vessels:

A vessel not under command or aground.	These vessels have no maneuverability.
A vessel restricted in its maneuverability.	These vessel are performing work which limits their maneuverability such as surveying, dredging, laying pipe or cable, servicing navigational markers among others.
A vessel engaged in fishing.	These include boats fishing with lines, trawl or nets; but not trolling lines.
Sailboats	Sailboats have the right-of-way over power boats; however, if a sailboat is using a propeller to move forward, it is considered a power boat even if its sails are up.

2. Meeting Head-On

When two boats meet head-on neither boat has right-of-way. Both boats should decrease speed and pass; port to port. However, if both boats are on the left side of a channel, each vessel should sound two short horn blasts and pass to starboard to starboard. See Figure C1.

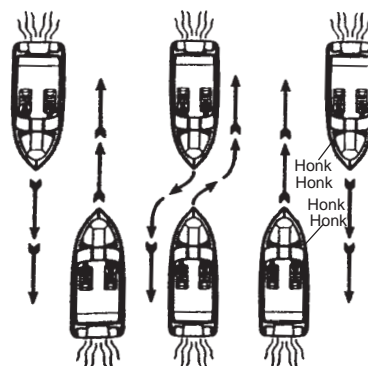

Figure C1: Meeting Head-On

3. Crossing Situations

In a crossing situation, the boat on the right from the 12-4 o'clock position has the right-of-way. It must hold course and speed. The boat without the right-of-way must keep clear and pass to the stern. See Figure C2.

Stand-on (Privileged) Vessel holds course and speed.

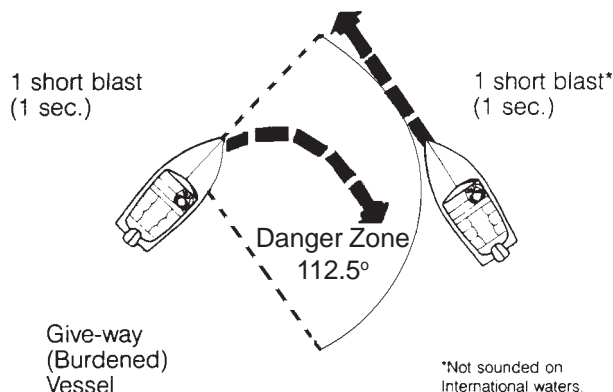

Figure C2: Crossing Situation

4. Overtaking

The boat overtaking the one ahead must yield the right-of-way to the boat being passed. The overtaking boat must make necessary adjustments to keep out of its path. The boat being passed should hold its course and speed. See Figure C3.

Inland Rules

"I want to pass you on your port side."

2 short blasts (1 sec.)

"Proceed"

2 short blasts (1 sec.)

International Rules

"I am altering my course to port."

2 short blasts (1 sec.)

International Rules in Narrow Channels

"I intend to pass you on your port side."

2 prolonged blasts (4-6 sec.)
2 short blasts (1 sec.)

"Proceed."

1 prolonged, 1 short
1 prolonged, 1 short

Stand-on (Privileged) Vessel Being Overtaken

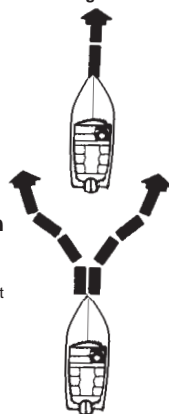

Give-way (Burdened) Vessel Overtaking

Inland Rules

"I want to pass you on your starboard side."

1 short blast (1 sec.)

"Proceed"

1 short blast (1 sec.)

International Rules

"I am altering my course to starboard."

1 short blast (1 sec.)

International Rules in Narrow Channels

"I intend to pass you on your starboard side."

2 prolonged blasts (4-6 sec.)
1 short blast (1 sec.)

"Proceed."

1 prolonged, 1 short
1 prolonged, 1 short blast

Figure C3: Overtaking

5. The General Prudential Rule

The general prudential rule regarding right-of-way is that if a collision appears unavoidable, neither boat has right-of-way. As prescribed in the "Rules of the Road", both boats must act to avoid collision.

6. Night Running

Boats operating between sunset and sunrise (hours vary by state), or in conditions of reduced visibility, must use navigational lights. Nighttime operation, especially during bad weather or fog, can be dangerous. All "Rules of the Road" apply at night, but it is best to slow down and stay clear of all boats regardless of who has right-of-way.

To see more easily at night, avoid bright lights when possible. Also, it is helpful to have a passenger keep watch for other boats, water hazards, and navigational aids.

To determine the size, speed and direction of other vessels at night, you should use running lights. A green light indicates the starboard side, and the red light indicates the port side. Generally, if you see a green light, you have the right-of-way; if you see a red light, give way to the other vessel. See Figure C4.

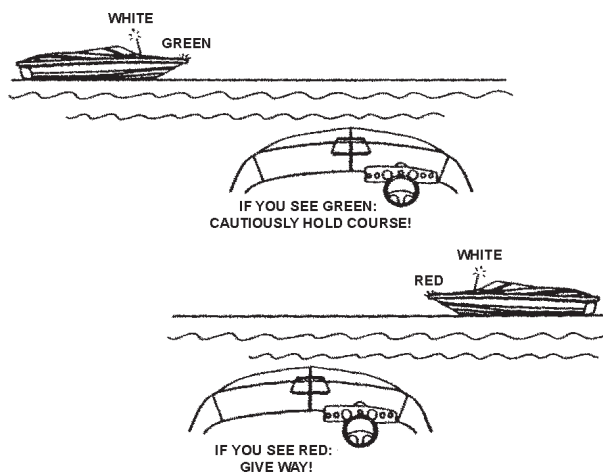

Figure C4: Night Running

7. Whistle Signal

Out on the water, whistle signals are commonly used. Although using a whistle signal is not necessary every time a boat is nearby, operators must signal their intentions when necessary to avoid potentially confusing or

hazardous situations. Use whistle blasts early enough to be noticed and understood by other boaters.

It is customary for the privileged boat to signal first and the yielding boat to return the same signal to acknowledge she understands and will comply. Use the danger signal (five or more short and rapid blasts) if intent is not clear. A short blast is one or two seconds long. A long blast is 4 to 6 seconds long. The Navigational Aids Chart at the end of this section lists the meanings of the various whistle signals.

C - 2 NAVIGATIONAL AIDS

Aids to navigation (ATONS) help you to travel safely on the water. They help you get from one place to another and are most helpful if you have a nautical chart. A navigational aids chart is at the end of this section.



WARNING

NEVER tie your vessel to an ATON. It is illegal because it blocks the ATON from view of other boaters. Decreased visibility can contribute to a serious accident which may result in property damage, personal injury, or death.

There are two ATON systems. The system used on federal waters is known as the International Association of Lighthouse Authorities System B (IALA-B). The Coast Guard maintains this system. The second system is the Uniform State Waterway Marking System (USWMS). This system is maintained by state authorities.

A. International Association of Lighthouse Authorities System B (IALA-B)

IALA-B uses four types of ATONS. This section discusses the two most common markers: lateral markers and safe water markers. Other federal markers include special markers and isolated danger markers. The Navigational Aids Chart at the end of this section shows these aids.

B. Lateral Markers

Lateral markers indicate the sides of navigable channels. They consist of lighted can or nun buoys and daymarks. Each has a number and is either red or green. The numbers on the green markers are odd. Red markers have even numbers.

Buoys are red or green floating ATONS. If lighted, they have either red or green lights. Unlighted green buoys, called cans, look like cylinders. Unlighted red nun buoys have a cone shaped top with their points cut off. Do not pass too close to a buoy. You may foul the propeller in its chain.

NOTICE

Buoys are anchored floating objects and may not always be in exactly the same position.

Daymarks are red or green boards with numbers. They are on posts or groups of pilings tied together and called dolphins. Daymarks and their supports are daybeacons. Daybeacons may or may not have lights. If a red or green daybeacon has a light, it is the same color as the marker-red or green. Red daymarks are triangular and have even numbers. Green daymarks are square and have odd numbers.

Red, Right, Returning is a basic rule to assist you in using lateral markers. When you are returning from seaward, keep red markers on the starboard (right) side when you pass them. Keep green markers to the port side.

Returning from seaward is very clear if you have been on the ocean. You are returning to port. By agreement, going upstream on a navigational river is returning from seaward. The outlet ends of the Great Lakes are also the seaward ends. Traveling from a large body of water to a smaller one is considered returning from seaward.

C. Safe Water Markers

Safe water markers have vertical red and white stripes and mark the center of navigable channels and fairways. Safe water markers included both lighted and unlighted buoys and daymarks. If a marker is lighted, the light is white and flashes the letter "A" is Morse Code.

Preferred Channel markers have horizontal red and green bands. If lighted, the color of the light is the same as the top of the band. They show the preferred channel for you to use at a junction point. Be sure to notice the color of the top of the band, and treat it as any other marker you would of that color. If the band is red and you are returning from seaward, keep the marker to the right.

Most lights on markers flash on and off. Others such as lights on aids with no lateral significance are fixed. They

stay on all night. ATON lights flash in regular patterns. For example, they may flash every three seconds, or in groups such as two flashes and a pause. There are a number of flashing patterns, which help you identify the light at night. To identify a light, note its color and pattern or timing of flashes, and compare it to your chart to find its location.

D. The Uniform State Waterway Marking System

This section discusses three kinds of markers in this system: Regulatory, Informational, and Lateral.

Regulatory markers in this system are either signs or buoys. Signs are square with orange borders. Regulatory buoys are white and shaped like cylinders. They have horizontal orange bands near their tops and just above the water's surface. An orange circle on a marker means a controlled area. A message such as "No Wake, Idle Speed, No Skiing, or 5 M.P.H." may appear on a marker. An orange diamond means danger. If a diamond has an orange cross inside it, do not enter the area. The reason you should stay out, such as "Swim Area" may be printed in black on the marker.

Informational Markers are white signs with orange borders. They give information such as direction, distance, and location.

Lateral markers in the USWMS system are either numbered red or black buoys. Black buoys may have green reflectors or lights. They are the equivalent of green buoys in the IALA-B system. Red buoys may have red reflectors or lights. They are the same as red buoys in the IALA-B system. Red or black buoys are usually found in pairs - pass between them.

E. A Special Sign

In Florida, you may see a special sign: "Caution, Manatee Area". When you see this sign, slow down to idle speed. Manatees, an endangered species, are passive, large, slow-moving mammals. Many Manatees are seriously injured or killed each year by boat propellers.

F. Noise

Always be aware of local laws on noise limits. Noise means engine noise, radio noise or even yelling by people on your boat. Good seamanship demands that you operate your boat quietly so as not to infringe on the rights of others. Do not use thru-hull exhaust unless you are well offshore.

C - 3 RECOMMENDED READING

We recommend that you read the boating literature published by your state boating agency and the U.S. Coast Guard. Other suggested reading includes the following:

Damford, Don. Anchoring. (ISBN 0-915160-64-1). Seven Seas.

United States Coast Guard Auxiliary. Boating Skills and Seamanship. LC74-164688.(illus.). (ISBN 0-930028-00-7). U.S. Coast Guard.

Bottomley, Tom. Boatman's Handbook, (illus.). 316 p. (ISBN 0-688-03925-1, Hearst Marine Book). Morrow.

Whiting, John and Bottomley, Tom. Chapman's Log and Owner's Manual. 192 p.(ISBN 0-686-96737-2). Hearst Marine Book.

Chapman, Charles F. and Maloney, E.S. Chapman's Piloting, Seamanship and Small Boat Handling. (illus.). 62 p. (ISBN 0-87851-814-2, Pub. by Hearst Bks.); deluxe ed. (ISBN 0-87851-815-0). Morrow.

National Fire Protection Association. Fire Protection Standard for Pleasure and Commercial Motor Craft. (ISBN 0-317-07388-5, NFPA 302). National Fire Protection Association.

Brotherton, Miner. Twelve- Volt Bible. (ISBN 0-915160-81-1). Seven Seas.

C - 4 CONTACTS

There are many good boating publications that have information about your area and what other boats are doing, such as clubs and other activities. Education programs are sponsored by publications and organizations such as the U.S. Power Squadron, U.S. Coast Guard Auxiliary and the American Red Cross. See your dealer about special courses available in the area. For detailed information contact:

American Red Cross
Local address (see local telephone directory)

Boat U.S. Foundation for Boating Safety Hotline
1-800-336-BOAT
1-800-245-BOAT (in Virginia)

U.S. Coast Guard Info Line
1-800-368-5647

NMMA Sources of Waterways Information - National Marine Manufacturers Association has five (5) booklets which list sources for safety, cruising, and local waterway information. Each covers a different region of the U.S. (North Central, South Central, Northeastern, Southeastern and Western). For single copies, write Sources of Waterways information, NMMA, 401 N. Michigan Avenue, Chicago, Illinois 60611. Ask for the booklet for your region.

Skippers Course
GPO Superintendent of Documents
Washington, DC 20012
202-512-1800
202-512-2250 (fax)

United States Coast Guard Auxiliary
Local Flotilla or contact appropriate Coast Guard
District Headquarters

United States Coast Guard Headquarters
2100 2nd St., SW
Washington, D.C. 20593-0001
202-267-1060

United States Power Squadron
P.O. Box 30423
Raleigh, NC 27617

C - 5 OWNER'S LOGS AND RECORDS

At the end of this owner's manual are several forms which you will find very helpful.

The **Float Plan** provides a record of your destination, departure and return times, boat description, passenger list, and other information about the trip you have planned. At the bottom of the form is space for listing emergency telephone numbers in case your return is delayed past the expected time. It also has space for indicating information about the person filing this report. Leave the completed form ashore with a responsible person. We recommend you make several copies of this form each boating season to assure an ample supply.

The **Fuel Log** is a handy way to record information covering engine hours, fuel consumption, miles traveled, as well as RPM (revolutions per minute), average M.P.H. (miles per hour) and GPH (gallons per hour).

The **Service/Maintenance Log** provides a record of maintenance work completed, the date of completion, and the engine hour reading. This log also helps you identify the frequency of routine maintenance work, such as engine oil changes. If you should decide to sell your boat, it demonstrates to perspective buyers that you have done a good job taking care of it.

The **Service Information Sheet** allows you to record all the pertinent information regarding your Four Winns® boat. This sheet will be extremely helpful when ordering additional/optional parts for your boat or when having service work done.

C - 6 NAVIGATIONAL AIDS CHART

The illustrated Navigational Aids Charts contain information concerning whistle signals, storm warnings, bridge signals, and buoy descriptions. See Figure C5 on the following page.

Navigational Aids Chart

REMEMBER THESE RULES

1. OVERTAKING - PASSING: Boat being passed has the right-of-way. KEEP CLEAR.
2. MEETING HEAD ON: Keep to the right.
3. CROSSING: Boat on right has the right-of-way. Slow down and permit boat to pass.

<p>← PORT</p> <p>Yield right-of-way to boats in your DANGER ZONE!</p> <p>STARBOARD →</p> <p>DANGER ZONE (Dead ahead to 2 points abeam to your starboard beam)</p>	<p>STORM WARNINGS</p> <table border="0"> <tr> <td></td> <td></td> <td></td> <td></td> </tr> <tr> <td>RED FLAG Small craft (winds to 33 knots)</td> <td>2 RED FLAGS Gale (winds up to 47 knots)</td> <td>SQUARE RED FLAG BLACK BOX (Storm)</td> <td>2 SQUARE RED FLAGS BLACK BOX (Hurricane)</td> </tr> </table>					RED FLAG Small craft (winds to 33 knots)	2 RED FLAGS Gale (winds up to 47 knots)	SQUARE RED FLAG BLACK BOX (Storm)	2 SQUARE RED FLAGS BLACK BOX (Hurricane)																							
RED FLAG Small craft (winds to 33 knots)	2 RED FLAGS Gale (winds up to 47 knots)	SQUARE RED FLAG BLACK BOX (Storm)	2 SQUARE RED FLAGS BLACK BOX (Hurricane)																													
<p>WHISTLE SIGNALS</p> <p>ONE LONG BLAST: Warning signal (Coming out of slip)</p> <p>ONE SHORT BLAST: Pass on my port side</p> <p>TWO SHORT BLASTS: Pass on my starboard side</p> <p>THREE SHORT BLASTS: Engine(s) in reverse</p> <p>FOUR OR MORE BLASTS: Danger signal</p>	<p>BRIDGE SIGNALS</p> <table border="0"> <tr> <td rowspan="2">SOUND</td> <td>VESSEL: Open</td> <td></td> <td rowspan="2">VISUAL</td> <td>DAY (Flag)</td> <td></td> <td>NIGHT (Lights)</td> <td></td> </tr> <tr> <td>BRIDGE: OK</td> <td></td> <td>VESSEL: Open</td> <td></td> <td></td> <td>Same</td> <td>Same</td> </tr> <tr> <td></td> <td>No</td> <td></td> <td>BRIDGE: OK</td> <td>Same</td> <td>Same</td> <td>No</td> <td></td> </tr> <tr> <td></td> <td>VESSEL: Replies:</td> <td></td> <td>No</td> <td></td> <td></td> <td></td> <td></td> </tr> </table> <p>RADIO: VHF CH. 13</p>	SOUND	VESSEL: Open		VISUAL	DAY (Flag)		NIGHT (Lights)		BRIDGE: OK		VESSEL: Open			Same	Same		No		BRIDGE: OK	Same	Same	No			VESSEL: Replies:		No				
SOUND	VESSEL: Open			VISUAL		DAY (Flag)		NIGHT (Lights)																								
	BRIDGE: OK		VESSEL: Open				Same	Same																								
	No		BRIDGE: OK	Same	Same	No																										
	VESSEL: Replies:		No																													

LATERAL AIDS AS SEEN ENTERING FROM SEAWARD

<p>PORT SIDE ODD NUMBERED AIDS</p> <p>GREEN LIGHT ONLY</p> <p>FLASHING </p> <p>OCCULTING </p> <p>QUICK FLASHING </p> <p>ISOPHASE </p> <p>LIGHTED BUOY (9) G "9" FI G 4sec</p> <p>CAN (7) G C "7"</p> <p>DAYMARK (1) G "1"</p>	<p>SAFE WATER MID-CHANNELS OR FAIRWAYS NO NUMBERS — MAY BE LETTERED</p> <p><input type="checkbox"/> WHITE LIGHT ONLY <input type="checkbox"/> MORSE CODE</p> <p>Mo (A) <input type="checkbox"/> <input type="checkbox"/> <input type="checkbox"/> <input type="checkbox"/> <input type="checkbox"/> <input type="checkbox"/> <input type="checkbox"/> <input type="checkbox"/></p> <p>SPHERICAL (G) RW SP "G"</p> <p>MR (A) RW "A"</p> <p>LIGHTED AND OR SOUND (N) RW "N" Mo (A)</p> <p>PREFERRED CHANNEL</p> <p>COMPOSITE GROUP FLASHING (2 + 1) <input type="checkbox"/> <input type="checkbox"/> <input type="checkbox"/> <input type="checkbox"/> <input type="checkbox"/> <input type="checkbox"/> <input type="checkbox"/> <input type="checkbox"/></p> <p>GREEN LIGHT ONLY</p> <p>RED LIGHT ONLY</p> <p>LIGHTED</p> <p>PREFERRED CHANNEL TO STARBOARD TOPMOST BAND GREEN GR "C" FI (2 + 1) CAN GR C "L"</p> <p>PREFERRED CHANNEL TO PORT TOPMOST BAND RED RG "B" FI (2 + 1) NUN RG N "W"</p> <p>DAYMARK (A) GR "A"</p> <p>DAYMARK (B) JR "B"</p> <p>DAYMARK (B) RG "B"</p>	<p>STARBOARD SIDE EVEN NUMBERED AIDS</p> <p>RED LIGHT ONLY</p> <p>FLASHING </p> <p>OCCULTING </p> <p>QUICK FLASHING </p> <p>ISOPHASE </p> <p>LIGHTED BUOY (8) R "8" FI R 4sec</p> <p>NUN (6) R N "6"</p> <p>DAYMARK (2) TR "2" R "2"</p>
--	---	---

Figure C5: Navigational Aids Chart

WARRANTY AND SERVICE

D - 1 FOUR WINNS WARRANTY POLICY

The Four Winns Winning Edge™ Owner Protection Plan, provides the new Four Winns purchaser with one of the most comprehensive corporate commitments in the marine industry today. The Four Winns Owner Protection Plan defines the warranty coverage on all units manufactured by Four Winns. It thoroughly describes the warranty policies and those procedures to be followed to obtain warranty coverage. Review the Four Winns Owner Protection Plan and limited warranty statements carefully.

All engines utilized in the Four Winns® product are warranted by the engine manufacturer. Your Four Winns dealer is authorized to repair your engines and will work closely with the engine manufacturer to resolve any problems you have.

D - 2 DECK/HULL STRUCTURE WARRANTY

Each unit manufactured by Four Winns is encompassed by a separate warranty providing specific coverage on the deck/hull structure. The Four Winns Owner Protection Plan thoroughly describes this coverage.

D - 3 WARRANTY REGISTRATION

A Four Winns Warranty Registration Card is attached to the Four Winns Owner Protection Plan statement. Your Four Winns dealer is responsible for completing and mailing the warranty card at the time of purchase. The receipt of the warranty card is the sole basis for establishing proof of ownership of the boat and corresponding warranty validation.

By signing the warranty registration card you, the new owner, indicate an understanding of the terms and conditions of the Limited Warranty. The warranty registration card should be properly completed by the dealer, signed by the new owner, and returned to us within fifteen (15) days after the original purchase in order to validate the warranty. Be sure to keep the Owner's Registration Card for your records.

All boat manufacturers are required by The Federal Boat Safety Act of 1971 to notify first time owners in the event any defect is discovered "which creates a substantial risk of personal injury to the public." In order for us to comply with this law if it becomes necessary, it is essential that your warranty registration card with the owner's name, address, and boat serial number be completed and mailed to Four Winns L.L.C., 925 Frisbie Street, Cadillac, MI 49601.

Other equipment manufacturers also require that their products be registered with the respective companies. Warranty registration cards are provided in the owner's information packet.

D - 4 TRANSFER OF WARRANTY

Four Winns confidence in the product and our warranty commitments can extend after the original purchaser may choose to move on to a new boat. The remainder of the Four Winns warranty coverage is transferable to the second owner of the boat for a fee. The warranty may be transferred only once. Registration of the second owner is required and the amount of the transfer fee is indicated on the warranty statement of the Warranty Registration Card. Transfer of the remainder of the warranty must occur within five (5) years of the original retail sale. The transfer fee must be paid within fifteen (15) days of purchase of the used boat by check, money order or cashier's check payable to Four Winns. Proof of purchase date is required. We will notify the appropriate engine manufacturer of the engine warranty transfer. The Four Winns Owner Protection Plan thoroughly describes the action required to transfer warranty coverage.

D - 5 PRE-OWNED UNIT REGISTRATION

Section D-4 Transfer of Warranty discusses the need to properly register the purchase of a pre-owned boat with Four Winns in order to transfer applicable warranty coverage.

Purchasers of all Pre-Owned Four Winns® models, regardless of the decision to transfer warranty coverage, are encouraged to register ownership with Four Winns. To register ownership of a "Pre-Owned Four Winns®

boat,” provide Four Winns with your name, address, daytime phone number, e-mail address, purchase date, and hull serial number of the boat purchased. The hull serial number plate is permanently affixed to the starboard side of the transom.

Registration of a Pre-Owned Four Winns® boat does not extend or in any way affect or modify the specific terms of the Four Winns Owner Protection Plan or Limited Warranties.

We provide this service to the purchasers of Pre-Owned Four Winns® boats in the interest of better boating. Four Winns welcomes every purchaser of a Four Winns® boat, new or used, to our family.

D - 6 INSURANCE COVERAGE

One of your responsibilities as a new boat owner is to acquire proper insurance protection. Insurance should include comprehensive and general liability coverage appropriate to your financial needs. Please contact your local agent for assistance on insurance coverage.

D - 7 SERIAL NUMBER RECORD

The manufacturer, model, and serial number of major components are recorded during the assembly of each Four Winns® boat. A copy of this form is included in the owner's packet. Using this form, you may want to have your dealer help you complete the service information form at the back of this manual. A copy of the serial number record should be made and kept by the dealer in his records. This can assist the dealer in processing warranty claims, or obtaining necessary information. The original copy of the serial number record should be kept in the owner packet. The service information form should remain in the owners manual for easy reference.

D - 8 PRE-DELIVERY SERVICE

Four Winns makes every effort to deliver your boat in “turn key” condition to the dealer. The process of transporting and handling the boat necessitates certain inspections and adjustments prior to delivery to you. Also, various aspects of operation must be checked and adjusted immediately prior to final delivery and use.

The selling Four Winns dealer must perform this thorough review of the boat and its numerous systems during the commissioning or “dealer pre-delivery service” of the craft.

A Four Winns Pre-Delivery Inspection Form is part of the Warranty Registration Card. It lists the many items encompassed by the pre-delivery service previously described. The dealer is to check off the items as they are completed, and complete the form as indicated providing specific performance related information appropriately.

Your Four Winns dealer will sign the Pre-Delivery Inspection Form of the Warranty Registration Card upon completion of the work. You will also be asked to sign the Pre-Delivery Inspection Form upon accepting delivery of the boat. You are to retain the two copies marked “Boat Owner”. Your dealer is to retain the copy marked “Dealer copy” for his records. The Manufacturer's copy is to be mailed to the Four Winns Customer Service Department.

D - 9 REPLACEMENT PARTS

Four Winns dealers are equipped with a Four Winns parts manual that details the components of each model and their appropriate part numbers. Many Four Winns dealers inventory common replacement components.

In addition, Four Winns maintains specific records on the components used in the manufacture of each unit and makes a concerted effort to maintain components specifically to fill replacement part needs.

The Four Winns dealer from whom you purchased your boat is in the best position to meet your needs. If the dealer does not have the needed item, the dealer has the capability, through direct contact with the Four Winns Customer Service Department, to obtain it quickly. Four Winns will only sell replacement parts to established Four Winns dealers. If you relocate and cannot find a Four Winns dealer close to you, contact the Four Winns Customer Service Department for information on the nearest dealer in your area.

D - 10 OWNER'S RESPONSIBILITIES

1. Sign the warranty registration card verifying your address, model and hull serial number. The dealer is responsible for mailing the warranty registration card to us.
2. Inspect the boat at the time of delivery to verify that all systems and components are operating safely and acceptably. Read all manuals and instructions.
3. Operate all equipment in compliance with the manufacturer's instructions.
4. Review the pre-delivery checklist for the boat and engine with your dealer when you take delivery.
5. Schedule your 20-hour boat and engine checkup with your dealer.
6. Know how to safely operate your boat and the rules of the road before you use your boat.

IMPORTANT: Make sure that your dealer checks the engine alignment during your boat's 20-hour checkup. The engine alignment check should be performed in accordance with recommended procedures as stated by the engine manufacturer in your engine owner's manual. Failure to do so could result in drive train damage which is not covered under the warranty.

7. We recommend that you review your engine owners manual and warranty certificate for break-in advice, initial inspection and service requirements.
8. Perform or provide for the scheduled maintenance checks outlined in this manual and all related service guides and manuals.
9. You are responsible for any modifications made to the boat or its equipment that could affect the safe operation of the boat.

Along with boating, comes responsibility. Responsibility for safety, boating laws, and the environment. Please think about the future of our waterways, oceans and marine life while you're out enjoying them and take all necessary measures to help protect what natural habitats we have left. Keeping our waterways and marine habitats free from debris, and showing consideration for the creatures who thrive in these environments are some ways you can help assure the pleasure of boating for years to come.

The operator is also responsible for complying with the following procedures and operational requirements:

- State registration
- Insurance
- Warranty registration
- Warranty terms and conditions
- Rules of the road
- Break-in procedure
- Proper maintenance of the boat and its systems
- Safety equipment
- Safety training of passengers and crews
- Knowledge of boat systems
- Seaworthiness/operational inspection
- Safe operating practices
- Avoiding use of drugs/alcohol
- Environmental regulations
- Accident reporting

D - 11 CONSTRUCTION STANDARDS

All our boats meet or exceed the construction standards set by the U.S. Coast Guard and the American Boat and Yacht Council (ABYC) concerning:

- Navigational lights
- Factory installed fuel systems
- Engine and fuel tank compartment ventilation
- Flotation
- Steering systems
- Backfire flame arresters

We recommend that you see your dealer if you wish to modify factory-installed equipment or add new equipment. Your dealer is qualified to make such modifications or additions without placing the safety or design integrity of your boat at risk and without invalidating the warranty.

D - 12 WINN GEAR™

Show your colors! Four Winns offers a complete line of sports clothing designed to complement your new boat. Your Four Winns dealer has a complete catalog and pricing. Our Winn Gear line is also on display on our website at www.fourwinns.com.

ENGINES AND INSTRUMENTATION

E-1 GENERAL



WARNING

DO NOT attempt to service any engine without being totally familiar with the safe and proper service procedures. Do not attempt to maintain or adjust an engine while it is running. Certain moving parts are exposed and failing to shut off the engine can result in serious injury or death.

Four Winns does not manufacture engines. Because of the technical nature of the engines, all manufacturers of these items require that warranty and service problems be taken directly to an authorized dealer for resolution. The Four Winns® dealer from whom you purchased your boat will handle all warranty and service matters with the engine manufacturer for you.

In compliance with the Federal Boat Safety Act of 1971, all engine manufacturers require their products to be registered. A registration card is furnished with each new engine. When selling a Four Winns® boat, the dealer, along with the purchaser, should complete the information requested on these cards and return them to the respective engine manufacturers. Engine registration cards are provided with the engine and will usually be found with the owner's information packet.

Each manufacturer of the various marine power components provides an owners information manual with their product. This publication is included with this manual. It is important that you read the manual(s) carefully and become completely familiar with proper care and operation of the engine system. Be sure to read the section on winterization. Replacement costs associated with frozen engine components are quite substantial.

Also review the other sections in this manual, especially Sections I on Fuel Systems, and Section F on Control Systems.

E-2 ENGINE EXHAUST

The carbon monoxide in exhaust fumes can be hazardous. It is important for you and your passengers to be aware of the potential safety hazard created by exhaust fumes. Familiarize yourself with the symptoms of individuals overcome by carbon monoxide, and most importantly, ways you can protect yourself and your guests.



WARNING

DO NOT inhale exhaust fumes! Exhaust contains carbon monoxide which is colorless and odorless. Carbon monoxide is a dangerous gas that is potentially lethal.

Persons overcome by carbon monoxide may exhibit the following symptoms:

- a. Watering and itchy eyes
- b. Flushed appearance
- c. Throbbing temples
- d. Inattentiveness
- e. Inability to think coherently
- f. Ringing in the ears
- g. Tightness across the chest
- h. Headache
- i. Drowsiness
- j. Incoherence
- k. Nausea
- l. Dizziness
- m. Fatigue
- n. Vomiting
- o. Collapse
- p. Convulsions

IF YOU THINK EXHAUST FUMES ARE ENTERING YOUR BOAT, DETERMINE THE CAUSE AND HAVE IT CORRECTED IMMEDIATELY!

The following suggestions can help prevent exhaust fumes from entering the boat:

1. DO NOT allow the boat to remain stationary with the engine running for an extended period of time. Do not stand or swim near the exhaust output or outdrive when the engine is idling.

2. Use extreme caution while operating the engine in confined areas such as enclosed slips or congested piers. Operation under such conditions could easily lead to exhaust gasses (carbon monoxide) entering even though you may have all the hatches, windows, doors and portholes closed.
3. Persons sleeping can be easily overcome by carbon monoxide because they are unaware of its presence. Sleeping while the engine is running is not recommended. If persons are sleeping aboard while underway, those awake should monitor for carbon monoxide accumulation in the cabin; especially the sleeping areas.

WARNING

NEVER operate the propulsion engine while everyone on-board is sleeping. Fatal carbon monoxide poisoning can occur.

For additional information, refer to Section B-2 Carbon Monoxide.

E - 3 ENGINES

Consult the Engine Owners Manual included in the owner's packet for additional operation and maintenance information.

E - 4 PROPELLERS

Knowledge of the propeller is most easily gained through better understanding of the terminology used to refer to the aspects of propeller size and performance.

NOTICE

Never run with a damaged propeller. You can damage the engine or drive unit. Keep a spare propeller on board.

A. Diameter

Diameter is twice the distance from the center of the prop shaft to the extreme tip of a propeller blade. Increasing or decreasing propeller size will have a direct bearing on the rpm's (revolutions per minute) an engine will develop. This is due to the greater amount of propeller blade surface in contact with the water. See Figure E1.

B. Pitch

Pitch is a measure of helix angle, or angle of attack, of the rotating blade. Pitch is easily understood if one imagines the propeller rotating through a semisolid such as butter or jello. The distance the propeller will travel in one revolution is called "Pitch." Increasing or decreasing pitch will also have a direct bearing on engine rpm's because of the greater bite taken by the blade with each rotation. See Figure E1.

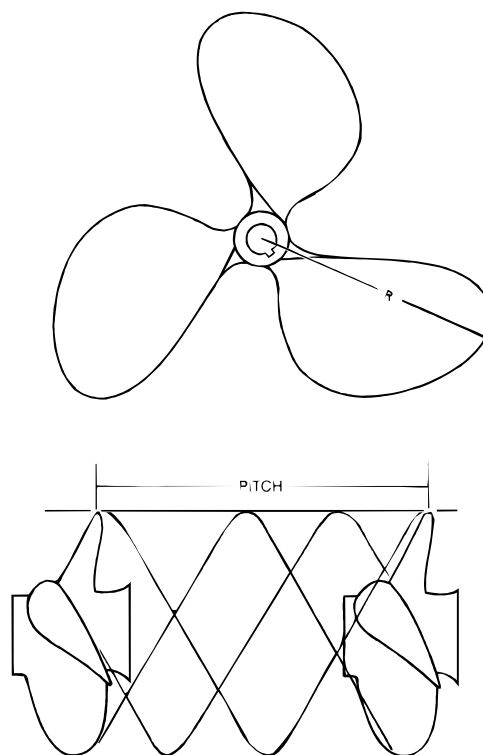

Figure E1: Propeller Pitch & Diameter

C. Prop Slip

When traveling through water a propeller is unable to get a complete bite because of the fluidity of water. "Prop Slip" is usually expressed as a percent of the computed theoretical speed. Fifteen to twenty-five percent prop slip is common for a sport-type boat operating at cruising speed.

Four Winns® boat provide the best general performance based on data obtained from on-the-water testing of that model. Variations in load, operating conditions, environment, the individual engine and hull performance may necessitate the purchase and use of another propeller(s).

Under your normal load conditions the engine(s) should turn within the maximum rpm range when at full throttle. If the engine(s) exceeds the recommended rpm, an increase in pitch and/or diameter is required. If the engine rpm is too low, a decrease in pitch and/or diameter is required.

An engine that is not developing full power and the load carried in a boat will directly affect performance of the engine. Always be sure the engine is properly tuned and load conditions are those normally experienced, before changing propellers.

For additional information on factors affecting performance, please consult your Four Winns® dealer.

E - 5 RUNNING ANGLE & POWER TRIM/TILT

Hull planing surfaces have the least amount of drag at a three to five degree angle with the water. This is the preferred running angle when boating. The running angle has a significant impact on top speed and handling. See Figure E2. Heavy load or certain water conditions may make it difficult to achieve the optimum running angle. The running angle can be controlled through the use of the power trim.

A. Power Trim

Trim angle is how far in or out, the drive or outboard motor is positioned in relation to the bottom of the boat. The trim angle of the drive has a distinct affect on the running angle of the boat.

The power trim system permits control of the trim angle of the drive relative to the boat, at the touch of a button. It allows the drive to be raised for shallow water operation. Power trim also allows the operator to adjust the drive while underway to provide the ideal running angle for a given load and water condition. Additional information can be found in the engine operator's manual included in the owner's packet.

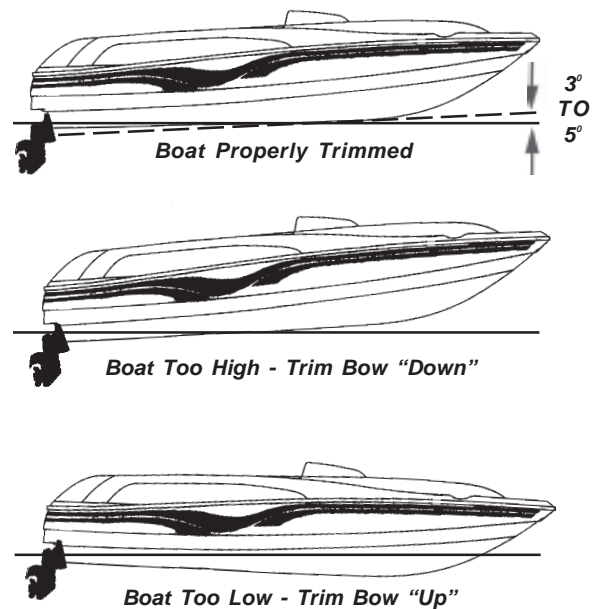

Figure E2: Running Angle

B. Power Tilt

Power tilt allows the operator to raise and lower the drive for trailering, launching, and beaching. Additional information on power tilt can be found in the engine operator's manual included in the owner's packet.

NOTICE

DO NOT operate the motor with the water intakes out of the water. Severe damage to the engine systems can result. Consult the engine operator's manual for specific information.

E - 6 ENGINE INSTRUMENTATION

The helm station on Funships™ is equipped with a complete set of individual engine instrument gauges. These instrument gauges allow the boat operator to constantly monitor the operational condition of the engine. Close observation of these instrument gauges could save the engine from damage. See Figure E3.



Figure E3: Funship™ Dash Panel

A. Tachometer

The tachometer indicates the speed of the engine in revolutions per minute (rpm). This speed is not the boat speed or necessarily the speed of the propeller. The tachometer may not register zero with the ignition key in the OFF position.

NOTICE

Never exceed the maximum recommended operating rpm of your engine. Maintaining maximum, or close to maximum rpm for extended periods can reduce the life of the engine.

Some engines are equipped with devices that limit engine rpm in accordance with the oil pressure, or engine temperature. Refer to the engine manual included in the owner's packet for additional information.

The tachometer must be set for different engines installed. This is typically done at the factory. The tachometer gauge for the Funships™ is shown along with the table detailing the tachometer settings. See Figure E4.

FARIA TACHOMETER SETTINGS

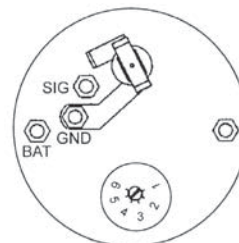

Set switch to match your engine.

CAUTION: Depress switch slightly while turning.

TACHOMETER SETTINGS	
NUMBER OF CYLINDERS	ENGINE SETTING
4*	1
6*	2
8*	3
12 POLE	4
(OB ALT)	
* 4 CYCLE ONLY	

Note: Setting information is labeled on the back of the tachometer.

Figure E4: Funship™ Tachometer - Rear View

B. Speedometer

The Funship™ speedometer is a water pressure sensitive unit. It has a pick-up (pitot tube) assembly mounted on the transom and a small plastic hose (speedo tube) that connects it to the speedometer gauge on the dash. See Figure E5. The pitot tube extends below the hull. Water strikes the tube inlet and creates positive pressure. The faster the boat speed, the greater the pressure, and the higher the speed indication on the speedometer.

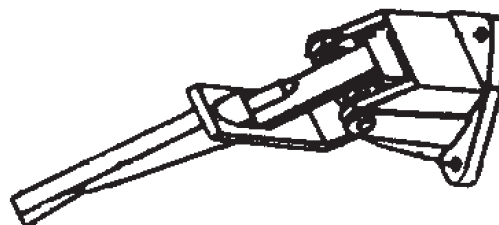

Figure E5: Funship™ Speedo Sender

If the pick-up becomes clogged, the speedometer will not register. Clean the opening with a piece of wire or disconnect the tubing and blow out the pick-up with compressed air.

When winterizing the boat, the speedometer tubing must be drained of water. Disconnect the speedometer hose at the pick-up assembly and at the gauge and blow through the tubing to remove the water.

NOTICE

Speedometers are not precision instruments. The indications are relative and should never be used for navigational purposes or similar critical situations.



CAUTION

DO NOT rely on the speedometer when trying to achieve a “NO WAKE” condition in a harbor or other enclosed waterway. ALWAYS reduce throttle! Speedometers are not effective at measuring low operational speeds. You are responsible for damage caused by the wake of your boat.

C. Temperature Gauge (4-in-1 Gauge)

The temperature gauge included in the 4-in-1 gauges monitor the cooling system of the engine. A sudden increase in the temperature could be a signal of a blocked cooling passage or a water pump malfunction.

NOTICE

Operation of an overheated engine can result in engine seizure. If an unusually high temperature reading occurs, shut the engine off immediately.

D. Oil Pressure Gauge (4-in-1 Gauge)

The oil pressure gauge indicates the pressure in the engine lubrication system. A significant drop in oil pressure is a possible indication of an oil pump or other leakage problem.

If the engine has been equipped with an audible engine alarm, the alarm should sound if the oil pressure drops below the normal operating range of the engine. Please see your engine owner’s manual for specific engine information.

NOTICE

Operation of an engine with abnormally low oil pressure can lead to engine damage and possible seizure. Have the engine serviced immediately upon a reduced oil pressure indication.

E. Voltmeter (4-in-1 Gauge)

The voltmeter monitors battery condition and thus alternator performance. See Section H for additional information regarding electrical systems.

F. Fuel Gauge (4-in-1 Gauge)

The fuel gauge displays the level of fuel that is present in the fuel tank. The fuel gauge will operate when the ignition switch supplying power to the fuel gauge is in the RUN position.

Due to the mechanical nature of the fuel sender, variations in readings during various speeds of operation may occur. This system is merely a relative indication of the available fuel supply and not a calibrated instrument. Relative adjustments can be made by your Four Winns dealer by bending the fuel sender float arm. Refer to Section I-1E Fuel Senders for additional information.

NOTICE

Use only clean fuel of the type and grade recommended by the engine manufacturer. The use of incorrect or contaminated fuel can cause engine malfunction and serious damage. Refer to Section I Fuel Systems for additional information.

G. Power Trim Gauge

Boats equipped with stern drives also have a “power trim gauge.” This gauge provides a visual indication of the inward-outward (trim angle) position of the outdrive. There is not a trailer travel mode on the gauge.

H. Depth Sounder

The depth sounder may be an available option on your Funship™ model. If so equipped, it consists of two main components, the transducer and the depth sounder. The transducer is mounted to the hull and the depth sounder is installed in the dash. The transducer and depth sounder communicate by means of a cable, and are powered by your boat’s 12-volt DC battery. The transducer and depth sounder use the basic principle of sonar to indicate the water’s depth. Please read the manufacturer’s literature

with the owner's packet for information regarding operation and maintenance.

General Description:

1. The depth finder will read to 199 ft. or the corresponding number of meters or fathoms. If the reading is less than 19.9 ft., meters or fathoms, 1/10th increments will be displayed. If the reading is more than 19.9 ft., all readings will be in whole numbers.

2. The depth finder has an audible and LCD display depth alarm with adjustable shallow and deep limits and a depth below keel offset feature. These settings once made are stored in memory and will remain even if the battery is disconnected.

Operation:

1. Power on. The depth sounder will activate automatically when the power to it is initially turned on. You do not have to press the combination "ON/OFF MODE" keypad. The LCD will illuminate showing the depth and will also show the type of units selected, feet (FT), meters (M), or fathoms (F). To turn the depth sounder off, press and hold the "ON/OFF MODE" keypad for 4 seconds. Press the "ON/OFF MODE" keypad again will reactivate the unit.

NOTE: The instrument is designed to have the internal LED lighting remain on as long as power is supplied even if the unit is turned "off" at the keypad.

2. Depth alarm. Shallow mode: Pressing the "ON/OFF MODE" keypad again displays the "SH" shallow depth alarm setting. This is the shallowest water that will activate the alarm. Press and hold the up or down arrow keypads to adjust the reading to the desired depth.

Deep mode: Pressing the "ON/OFF MODE" keypad again displays the "DP" deep depth alarm setting. This is the deepest water that will activate the alarm. Press and hold the up or down arrow keypads to adjust the reading to the desired depth. When the shallow depth setting is read by the depth sounder, the "SH" will flash on the LCD and the audible alarm will sound rapidly. When the deep depth setting is read by the depth sounder, the "DP" will flash on the LCD and the audible alarm will sound at 2 beeps per second.

NOTE: To fully deactivate an alarm, reset it to zero. Pressing the "ON/OFF MODE" keypad temporarily deactivates the alarm. To reactivate the alarm press the

"ON/OFF MODE" keypad until the depth reading appears.

3. Keel offset: Pressing the "ON/OFF MODE" keypad again displays the "KL" keel offset setting. This can be set so that the depth sounder either shows the depth below the keel or the depth below the transducer. Press the up or down arrow keypad to adjust the reading to the desired depth no more than 19.9 ft. For example if the bottom of the keel is 2 ft. below the transducer and you want the depth sounder to read the depth below the keel, the display should be adjusted to read 2.0 FT.

NOTE: Once a keel offset is programmed, the shallow and deep alarms will be activated by the depth below the keel.

4. Units. Pressing the "ON/OFF MODE" key pad again displays "Un" on the LCD indicating the units mode. Press either the up or down arrow keypads to set the units desired to feet (FT), meters (M), or fathoms (F). These units once set, will remain the same for all modes. Pressing the "ON/OFF MODE" keypad again returns the depth sounder to normal operation.

I. Ignition Switch

The ignition switch for the Funship™ models have four positions: OFF, RUN, ACCESSORIES, and START. The START position is spring loaded and the key should be held in this position until the engine starts. The key will return to the RUN position once released. Always turn the key to the OFF position when the engine is not running. This will prevent discharging of the battery(s). The ACCESSORIES position allows the operator to run the stereo without activating the other ship's systems. Additional information on ignition switch operation is covered in Section A Operation, of this manual.

J. Emergency Stop Switch

This safety device automatically stops the engine if the lanyard is attached to the operator and the operator falls from his work station. Refer to the engine manual for detailed information about using this switch.

The emergency stop switch (Figure E6) incorporates a shutoff switch, switch clip, lanyard, and lanyard clip. The lanyard clip must be securely attached to the operator's PFD, clothing, arm, or leg. Be sure to attach the lanyard to a place where it is free of obstructions and to something that will move with the operator if he or she leaves the helm station. If the engine shuts down because this switch was activated, the clip may

have to be reinstalled on the interrupter switch before the engine can be started.

WARNING

Keep emergency stop switch lanyard free from obstructions that could interfere with its operation. Do not modify or remove emergency stop switch or bypass its safety features. The proper use of the emergency stop switch will prevent a runaway boat situation which can cause severe personal injury or death.

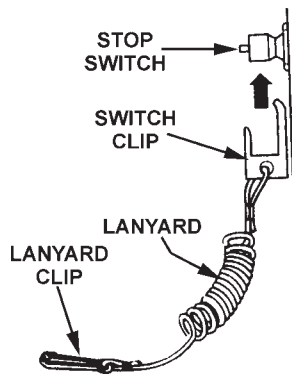

Figure E6: Emergency Stop Switch

The emergency stop switch can only be effective when in good working condition. Observe the following:

1. Lanyard must always be free of entanglements that could hinder its operation.
2. Once a month, check the switch for proper operation. With engine running, pull lanyard. If the engine does not stop, see your Four Winns dealer.
3. Once a month, inspect both the clip and lanyard for cuts, breaks or wear. Replace worn or damaged parts.

In an emergency situation, any occupant of the boat can restart the engine. Just press in and hold the emergency stop switch button, then follow normal starting procedures. When the button is released, the engine will stop.

CAUTION

Avoid knocking or pulling the clip or lanyard from the switch during regular boating operation. Occupants may be thrown forward or possible engine damage may occur by the sudden loss of engine power.

K. Engine Hour Meter

Engine hour meter is optional on all Funship™ models and provide a numeric record of elapsed engine operating time. This information is important in determining scheduled maintenance intervals, ships log data, cruise information, etc. If so equipped, the hour meter will be located in the engine compartment.

The hour meter is connected to the ignition switch. Be sure the ignition switch is in the OFF position when the engine is not operating or the hour meter will record additional time.

L. Alarm Systems

Engine alarm systems are available on certain engine options for the Funship™ models. The alarm is audible and is actuated by various engine sensors. The sensors monitor such things low oil pressure, high water temperature levels and high exhaust manifold temperatures. Consult your engine owner's manual for information regarding the specific systems monitored by the alarm if so equipped.

M. Instrument Maintenance

Electrical protection for instruments and ignition circuitry is provided by fuses. The fuse block is located underneath the starboard dash on the Funship™ models.

Periodically, spray the ignition switch with a contact cleaner. The ignition switch and all instruments, controls, etc. should be protected from the weather when not in use. Four Winns offers appropriate weather covers for each model. Excessive exposure can lead to gauge and ignition switch difficulties.

CAUTION

DO NOT use a product such as WD-40 as a contact cleaner. Be sure to read the label before using any product

Electronic gauges are affected by static electricity that builds-up on the glass face. Periodic washing on the gauge face with warm water and mild liquid detergent will help eliminate the static electricity problem and improve gauge accuracy.

CONTROL SYSTEMS

F - 1 GENERAL

Control systems permit operation of the engine's throttle and shift mechanisms. They consist of three major components; the control, and the throttle and shift cables.

Your Four Winns® boat is equipped with a single lever concealed side mount control. This allows you to select forward or reverse gear, regulate engine speed, and ensure shifting is done at low engine speed.

A "start-in-neutral-only" feature which prevents starting in gear is included. Refer to F-3 Neutral Safety Switch in this section.

Also, the side mount control has a neutral lock button to prevent accidental shifting. It must be squeezed to permit shifting from neutral to forward or reverse.

Built into the control is a trim control which you can use to adjust the position of the outdrive. Pressing the switch in the UP position moves the outdrive out and away from the transom. Pressing the switch in the DOWN position moves the outdrive in closer to the transom. The switch returns to its center neutral position when released. For additional information see Section E-5.

Neutral is in the center or straight up position. Rotating the control forward shifts the engine into forward. Rotating the control aft shifts the engine into reverse. Moving the lever further forward or aft increases engine speed.

NOTICE

When shifting, ensure engine speed is below 800 RPM to avoid damaging the shifting mechanism.

NOTICE

Allow the engine to warm up before engaging the shift control. Monitor all instruments while engine is idling during warm-up.

Specific information on controls and their operation can be found in the section on "Starting and Operation" in the engine manufacturer's manual included in the owner's packet.

F - 2 CONTROL OPERATION

A. Carbureted Engines

The shift mechanism on the controls can be disengaged to allow for easier starting and engine warm-up. See Figure F1. To disengage:

1. Place control handle in neutral position (B).
2. Press both neutral lock button (A) and shift disengage button (C).
3. Move control handle forward to increase throttle.

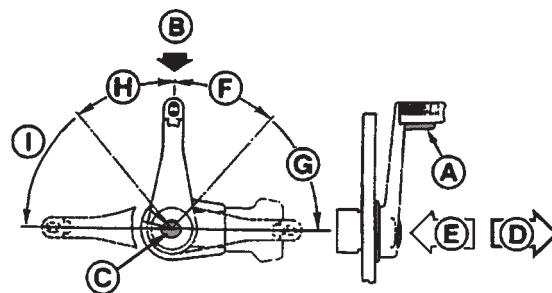

Figure F1: Control Operation

The neutral lock and shift mechanism will automatically engage when the control handle is returned to the neutral position.

4. Shift Mechanism Engaged (D).
5. Shift Mechanism Disengaged (E).
6. Reverse Shift Range (F).
7. Reverse Throttle Range (G).
8. Forward Shift Range (H).
9. Forward Throttle Range (I).

Refer to the engine manual, included in the owner's packet, for additional information on control operation.

B. Fuel Injected Engines (EFI)

On fuel injected engines, starting the engine is much easier and faster. It is not necessary to use the throttle while in neutral to cold-start the engine. Simply turn the key and allow the engine to warm up.

For additional information, refer to the section on “Starting and Operation” in the engine manufacturer’s manual included in the owner’s information packet.

F - 3 NEUTRAL SAFETY SWITCH

Control systems usually incorporate neutral safety switches within their design. This device prevents the engine from being started while the shift lever is in any position other than the neutral position. If the engine will not start, slight movement of the shift lever may be necessary to locate the neutral position and disengage the safety cut-out switch. Control or cable adjustments are required to correct this condition should it persist. See your Four Winns dealer for necessary control and cable adjustments.

F - 4 CONTROL SYSTEM MAINTENANCE

Periodic inspections of the control, cables, and all connections should be made. Signs of looseness, rust, corrosion, wear, cable jacket cracks or other deterioration require immediate system servicing. Replace all damaged components.

Generally, periodic lubrication of all moving parts and connections with a light, waterproof grease is in order. Cables can be lubricated by positioning them to their fullest extension and applying light grease to the inner cable near the jacket. Working the cables back and forth will distribute the grease in the inner cable. Reapply the grease if necessary.

Lubrication should be performed as often as necessary to keep the system operating smoothly. Cable manufacturers such as Teleflex and Morse often offer special tools to make cable lubrication easier.

Cable and control adjustments may become necessary. Adjustment screws in the control, on the cables and in the linkage are provided.



DO NOT attempt control adjustments unless you are familiar with control systems service procedures. Control misadjustment can cause loss of control.

Other lubrication, adjustment and maintenance instructions are provided by the control manufacturer and are included in the owner’s information packet.

STEERING SYSTEMS

G - 1 GENERAL

Four Winns® boats are equipped with rotary or hydraulic type steering systems. Tilt and power steering are features which are available on most models.

A. Rotary Steering

In the rotary system, a rotary drum assembly is mounted under the dash behind the steering wheel with a one piece cable running through the boat into the engine compartment. At the transom, the cable turns and is connected to the engine. Additional information on steering operation can be found in Section A-9.

B. Tilt Steering

The Funship™ models are equipped with tilt steering. To operate, depress the release lever (adjusting tab) with your thumb to tilt the steering wheel. Be sure to hold the top of the wheel to assist in positioning. Release the lever once the steering wheel is in the position desired. See Figure G1. Refer to the steering manufacturer's literature, included in the owner's packet, for additional information.

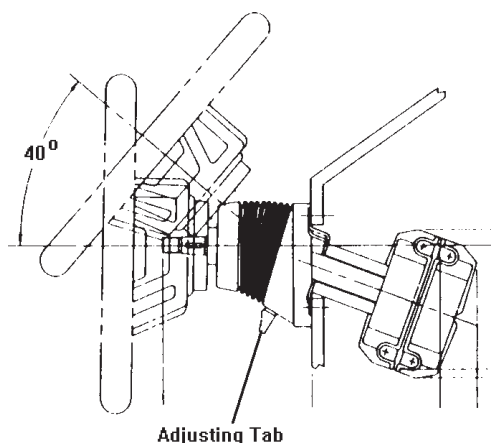

Figure G1: Tilt Steering Option

WARNING

The tilt mechanism should not be adjusted when the boat is moving. Sudden boat movement may cause loss of balance resulting in loss of control and/or injury.

WARNING

The tilt mechanism is spring loaded. Due to the variation in steering wheel offerings, the wheel may spring up rapidly when depressing the release lever. **ALWAYS KEEP ONE HAND ON THE WHEEL DURING TILT ADJUSTMENT OR INJURY MAY OCCUR.**

C. Power Steering

Power steering is also available. It is comprised of an engine mounted pump, hoses and steering cylinder. Power steering works in conjunction with the helm and steering cable to move the transom mount tiller arm and vertical drive more smoothly.

This is a "power assist" system and can greatly reduce steering effort required. It is not, however, a full power steering system as is used in automobiles. Some steering tension remains in the system.

On models with power steering, restricting movement of the steering cable will limit or stop the steering system's hydraulic assist.

NOTICE

DO NOT interfere with or restrict steering cable movement through the last 90° of bend at the engine. DO NOT use cable retainers, clamps or tie straps. Using one or all of these could restrict the cable movement near the engine. DO NOT tie wiring harnesses or other control cables to the steering cable. Make sure the deck coaming pads and bulkheads allow for steering cable movement in all positions of trim.

If the power steering becomes inoperative, steering will be harder and more effort will be needed to steer the boat. Check for a broken or loose belt on the power steering pump. Also, low fluid levels in the power steering pump reservoir will cause hard steering. If these items are not the source of the problem, check for equipment or other items lying on or up against the steering cable at the back of the boat. The cable must be free and clear to slide back and forth. Any item blocking free movement of the cable will result in harder steering and possible damage to the steering cable.

If the power steering system cannot be corrected on board, proceed at a reduced speed. The boat will be steerable, but with increased effort. Return the boat to your Four Winns dealer as soon as possible to correct the power steering system.



CAUTION

If equipped with power steering, check the fluid level in the reservoir periodically. Low power steering fluid levels may increase steering difficulty.



CAUTION

After the first two hours of running time, check the entire steering system for loose bolts, nuts and fasteners which could adversely affect steering control.

NOTICE

When storing equipment in the engine compartment, be sure to avoid contact with the steering cable. Cables may become kinked or damaged and may increase steering effort.

Most Four Winns® boats equipped with stern drives are equipped with power steering. This is a “power assist” system and can greatly reduce steering effort required.

NOTICE

DO NOT force the steering unit to either extreme. This can place undue strain on the unit and can lead to hydraulic line or seal failure.

It is important that the power steering fluid be maintained to the proper level. If equipped with a power steering unit, please consult the engine manual for additional information. The engine manual is included in the owner’s packet.

For additional information, refer to the steering manufacturer’s literature included with this manual. Also, refer to the section on Steering in your engine manual.

G - 2 PROPELLER TORQUE

The propeller rotation of a single engine with single propeller installation will exert a directional force on the steering system. This can cause the steering to be harder in one direction than the other, and is called propeller torque. If this occurs, adjust the drive trim. Refer to the engine manual, included in the owner’s packet, for information on adjusting the trim.

Propeller torque can also cause the boat to wander (not follow a straight line) when operated at low speeds. This condition is normal and can be corrected only by increasing engine rpm. Wind, water currents and play in steering components can cause equivalent effects.



CAUTION

Steering effort can vary significantly with engine acceleration, steering angle, trim angle, and sea condition. Be prepared for additional steering loads at all times.

G - 3 STEERING SYSTEM MAINTENANCE

A. General Maintenance

A periodic inspection of all steering cables, linkage and helm assemblies should be made. Signs of corrosion, cracking, loosening of fastenings, excessive wear, or deterioration should be immediately corrected. Failure to do so could lead to steering system failure and corresponding loss of control.

NOTICE

Check all bolts, nuts and fasteners for tightness.

B. Rotary System Maintenance

The helm and cable assembly should be so adjusted that the steering wheel is centered with the drive or outboard engine in the straight ahead position. There should be an equal number of turns to port and starboard from the straight ahead position. If adjustment becomes necessary, see your Four Winns dealer.

Check all metal parts at the cable output end for corrosion. Remove any old grease from the cable ram and motor swivel connections using a mild solvent such as WD-40. Spray the cleaned areas with a moisture-displacing lubricant and apply a light coat of good quality marine grease. Do this with the ram fully extended. See Figure G2.

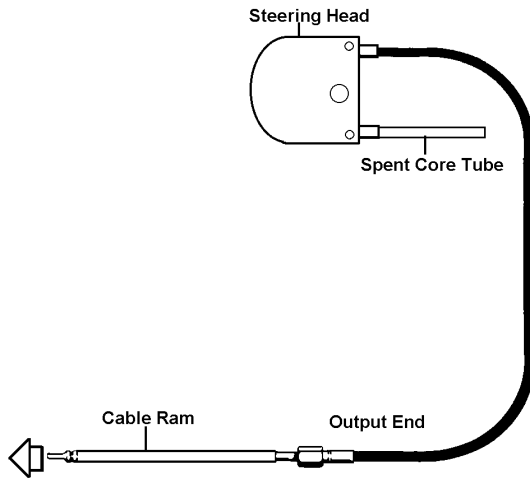

Figure G2: Steering Cable

C. Winter Storage

If the boat is placed in winter storage or used infrequently, clean the cable ram as instructed above. Cycle the steering several times when applying lubricant. If at any time the steering system becomes stiff, has an excessive amount of freeplay or shows any change in its operating characteristics, contact your Four Winns dealer to have the system inspected.

ELECTRICAL SYSTEMS

H - 1 GENERAL

All electrical equipment on Four Winns® boats operate on 12 volt DC electrical power.

WARNING

Fire or Explosion Hazard!

Electrical system parts are designed by and manufactured to comply with the U.S. Coast Guard requirements to minimize risks of fire or explosion. **Never substitute automotive parts for marine parts.** Automotive parts do not provide the necessary ignition spark protection.

WARNING

To prevent equipment or electrical wiring damage, DO NOT tamper with any electrical connection, panel or harness, or attempt installation of any electrical equipment unless thoroughly familiar with the systems and are experienced in making such installations.

For detailed information on the electrical system, electrical schematics are located in the back of this manual.

H - 2 BATTERY SYSTEM

A. Single Battery System

A single battery is provided as standard equipment (12 volt DC) per Section H-1 above. The dash components are protected by a fuse panel. Refer to Figure H1 and to the wiring schematics in the back of this manual.

When installing the battery, proceed as follows:

1. Connect the red (positive) cable running from the engine starter solenoid to the positive (+) battery terminal.
2. Connect the black (negative) battery cable running from the engine block to the negative (-) battery terminal.

CAUTION

When disconnecting the cables from the battery, make sure all switches are off and disconnect the black negative cable first to prevent spark.

NOTICE

DO NOT disconnect the battery while the engine is running. Alternator damage could result.

Monitor the battery's condition regularly with the voltmeter in the dash panel. For additional information, refer to Section H-4 Electrical System Maintenance.

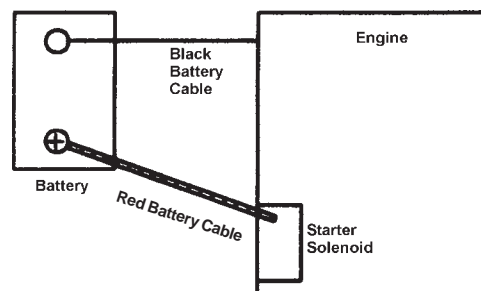

Figure H1: Single Engine-Single Battery Installation

B. Dual Battery w/ Switch - Optional

Dual batteries with a selector switch is optional on certain Funship™ models. This allows DC power to be used from either one or both batteries. Refer to Figure H2.

When installing dual batteries, proceed as follows:

1. Connect each of the red battery cables leading from the battery selector switch to the positive (+) terminal on each of the two batteries.

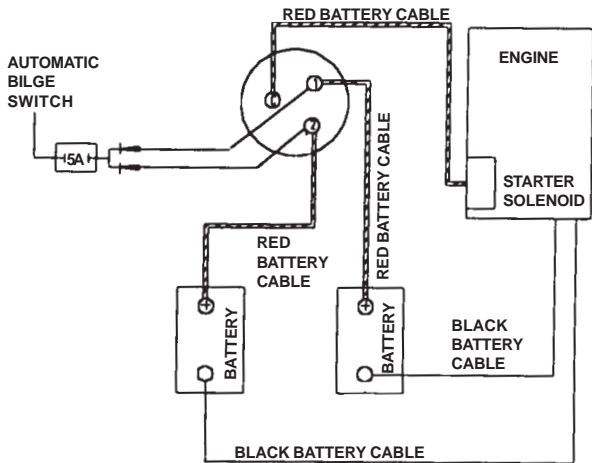

Figure H2: Single Engine-Dual Battery Installation

NOTICE

Be sure both cables are installed on the positive (+) battery terminals.

2. Connect the black battery cable to the port negative (-) battery terminal (see Section H-2 above). Connect the other black battery cable to the starboard negative (-) battery terminal.

WARNING

When disconnecting the cables from the battery, make sure all switches are off and disconnect the black negative cable(s) first to prevent spark.

C. Battery Switch Operation

Power to the engine and all 12 volt electrical equipment (except the automatic bilge pump) is controlled by the battery selector switch. See Figure H2.

Battery selector switch positions for the Funships™ equipped with this option are as follows:

“OFF” - With the battery selector switch in the “OFF” position, all 12 volt power to the boat is shut off completely except to the automatic bilge pump. A separate fuse is provided on the battery switch panel for the automatic bilge pump. Always turn the battery selector switch to the “OFF” position when the boat is removed from the water.

NOTICE

DO NOT turn the battery selector switch to the “OFF” position while the engine is running. Alternator and wiring damage could result.

“1” - Turning the switch to position “1” will use battery #1 to power the engine and 12 volt equipment. Battery #2 will be isolated and remain in reserve. Only battery #1 will be charged by the alternator.

“2” - Turning the switch to position “2” will use battery #2. Battery #1 is isolated and remains in reserve. Only battery #2 will be charged by the alternator.

“ALL” - With the battery selector switch in the “ALL” position, the batteries are connected in parallel. Both batteries will be used by the engine and all 12 volt equipment. Both batteries will be charged by the alternator. However, the batteries will charge at a slower rate compared to setting the switch in the other positions.

The use of one battery at a time is recommended. Position the battery selector switch to either the #1 or #2 position.

Under normal conditions, avoid using the “ALL” position. Use the “ALL” position only when a single battery is not capable of starting the engine.

Four Winns recommends alternating between batteries during boating. Depending upon boating use, this may increase battery longevity. Use battery #1 for the first day of a cruise and switch to battery #2 on the second day.

Position the battery selector switch to the battery that has sufficient power to start the engine (normally position “1”). After the engine is running, turn the battery selector switch to the battery that has the lowest charge. This will allow the alternator to charge the low battery. Utilizing the battery selector switch in this manner (instead of using the “ALL” position) will supply a greater charge to the battery.

FOR EXAMPLE: If battery #1 is fully charged and battery #2 is in need of a charge, use battery #1 to start the engine. After the engine is running and warmed-up, turn the battery selector switch to the #2 position. This will permit the alternator to charge the low, #2 battery.

H - 3 12 VOLT ELECTRICAL EQUIPMENT

A. Helm Equipment

The ignition, DC outlet, and panel switches are protected by a separate fuse panel located underneath the helm console. Access to the fuse panel may be gained by going underneath the helm console. Descriptions of individual switches are describe in the following:



CAUTION

To avoid equipment damage or electrical fires, use only replacement fuses that are of equal rating to the original fuse. Refer to the electrical schematic included with this manual for proper sizes.

Horn - To sound the horn, push the HORN button.

12 Volt DC Receptacle - Permits the use of additional 12 volt equipment such as a cell phone. Using the appropriate adaptor, the equipment draws power from the boat's battery.

Aft Bilge Pump - The PUMP switch at the dash is used to manually activate the bilge pump in the engine compartment. The bilge pump is used to remove water from the bilge (bottom of the hull) area of the boat by pumping the accumulated water overboard.

On all Funship™ models, the aft bilge pump is equipped with an automatic bilge switch and will operate whenever bilge water rises above the pump stop level. This will cause the internal float to move upward and activate the pump.

When leaving your boat unattended for an extended period, check the charge on the battery(s) periodically. Also check the water level in the bilge and make sure the float switch is functional.

If the automatic bilge pump must be disabled, disconnect the wiring plug near the bilge pump.

Bilge Blower- The BLOWER switch is used to activate the bilge blower. The bilge blower is used to remove any gas vapors that may have accumulated in the bilge or engine areas.



WARNING

Gasoline vapors can explode resulting in injury or death.

1. Before starting the engine, check the engine compartment bilge for gasoline or vapors.
2. Operate blower for four (4) minutes, and verify blower operation. Run blower when vessel is operating below cruising speed.

To verify blower is operating place your hand over the vents. DO NOT rely on the sound of the blower. Be sure a substantial amount of air is being exhausted by the bilge blower. Check the bilge blower system often, preferably before each cruise.

Navigation & Anchor Lights - Moving the NAV/ANC LTS switch towards the NAV position activates the bow lights and the all-around light or both portions of the mast light. Move the switch to the ANC position to activate the all-around light or both the fore and aft portion of the mast light. The center switch position is OFF.

Wipers - The WIPER switch activates the windshield wiper. This is an option for the starboard side only.

Accessories - Additional 12 volt equipment may be added to the boat using an accessory switch. Certain accessories may be wired directly to the fuse block below the dash. For more information, refer to Section H-3B Installation of Additional 12 Volt Equipment.

Cockpit Lights - The CKPT LTS switch is used to activate the cockpit (courtesy) lights.

B. Installation of Additional 12 Volt Equipment

On the fuse panel, non-factory installed 12 volt accessory equipment can be connected to the "ACC" (Accessory) terminal. Accessory equipment can also be wired directly to the newly installed "ACC" switch on the dash.

 **CAUTION**

Be sure to provide proper fuse protection for all 12 volt equipment that is installed. Accessory current should be limited to 15 amp if the connection is made to the fuse block. If the "ACC" switch is used, the current should be limited to 15 amp. Gauge and 12 volt equipment may operate improperly and cause possible internal damage at higher levels.

C. Interior Equipment

Stereo - On the Funship™ models, the stereo is mounted on the starboard console, at the walk-thru area, above the storage compartment door. The stereo remote is mounted to the dash. For stereo operation, please refer to the manufacturer's manual included in the owner's information packet.

NOTICE

Please note that when the ignition switch is placed in the off position the stereo is also shut off.

H - 4 ELECTRICAL SYSTEM MAINTENANCE

A. Battery Maintenance

Be sure to keep the batteries charged. Also, keep the batteries clean, especially the terminals and connection lugs. The battery cables must be fastened securely while in use.

Check the battery fluid level often, especially when a charger/converter is being used. Recharge a battery indicating a low voltage. Determine the reason for the discharge. Alternating battery usage with dual batteries (if applicable) is important. Refer to the Electrical System section in the engine manufacturer's manual for additional information on care and maintenance of batteries.

 **DANGER**

Batteries produce hydrogen and oxygen gases when being charged. These explosive gases escape through the vent/fill caps and may form an explosive atmosphere around the battery if the ventilation is poor. This gas may remain around the battery for several hours after charging. Sparks or flames can ignite the gas and cause an explosion.

 **WARNING**

Fire or Explosion Hazard!

Only qualified personnel should install batteries and perform electrical system maintenance. Do not expose batteries to open flame or sparks. Do not smoke near batteries.

 **WARNING**

Poison!

Sulfuric acid in batteries can cause severe burns. Avoid contact with skin, eyes, or clothing. Wear goggles, rubber gloves and protective apron when working with batteries. In case of skin contact, flush with water at least 15 minutes. If swallowed, drink large quantities of water or milk. Follow with Milk of Magnesia, beaten egg or vegetable oil. Get medical attention immediately.

 **WARNING**

Disconnect the battery before working on electrical or ignition system to prevent electrical shock and accidental ignition.

B. Electrical Wiring Maintenance

Periodically, inspect all wiring for nicks, chaffing, embrittlement, improper support, etc. Spraying the electrical connections with an electrical connection cleaner will reduce corrosion and improve electrical continuity.

 **CAUTION**

DO NOT allow corrosion to build up on connections. This can cause equipment to operate improperly.

The American Boat and Yacht Council (ABYC) has published a standard for the color coding of boat wiring. Four Winns voluntarily complies with these standards so the owner of the new boat can easily install new equipment or troubleshoot the electrical system. The following table summarizes the color code system:

Wire Color	Wire Designation
Red	Wires on positive (+) side of battery that go to starter. This wire is non-protected.
Red/Purple Stripe	50 amp protected wire that runs from the engine to the fuse panel at the helm.
Yellow with Red Stripe	Wire from starter switch to starter solenoid.
Yellow	Power lead to bilge blower from a fuse or switch.
Dark Gray	Sensor wire from tachometer sender to tachometer.
Brown/Red	Leads to bilge pump from switch.
Brown/Orange	Leads to auto bilge pump.
Purple	Wire between ignition switch and coil. Wire from ignition switch through distribution panel to electrical instruments.
Orange	Accessories
Dark Blue	Wire from switch to instrument lights.
Light Blue	Sensor wire from engine oil pressure sender to oil pressure gauge.
Tan	Sensor wire from water temperature sender to water temperature gauge.
Pink	Sensor wire from fuel tank level sender to fuel gauge.
Purple/White	Trim position
White/Green	Trim down
White/Blue	Trim up
White/Red	Trim power
Black	Ground
Gray/Green	Bow light
Gray/Blue	Stern light

Note: Some of these colors can serve more than one type of circuit.
Wiring Color Codes

H - 5 STRAY CURRENT CORROSION

A. General

Electrically induced underwater corrosion occasionally affects boats and their related components. This is referred to as “Stray Current Corrosion” and appears as surface pitting or deterioration. Stray current corrosion is the

decomposition of chemical compounds by electric current.

Stray current corrosion can be caused by the polarity of the dockside wiring system of the boat being reversed from the power source (reversed polarity) or surrounding boats, an improperly wired battery installation, other boats that are in close proximity that have electrical power leakages, or any other source close to the boat that has electrical power leakage into the water. Stern drive units are especially vulnerable to stray current corrosion.

Periodically inspect the drive components and thru-hull fittings to determine if stray current corrosion damage exists. If corrosion damage is found, determine and correct the cause of stray current to prevent further damage. Consult an experienced marine electrician or contact your Four Winns dealer for assistance.

The use of some shore power battery chargers, while the boat is in the water and the battery is connected to the system, can cause stray current corrosion. Have an experienced marine electrician review any battery charger installation to ensure a stray current corrosion problem will not develop. An improper battery connection is a common cause of stray current corrosion.

NOTICE

Use only “Coast Guard” approved battery chargers. Consult your Four Winns dealer for his recommendations.

Corrosion is usually more prevalent in polluted or salt water than in clean water. It is also more likely to occur when dockage is in an area with steel piers, large metal boats, or where shore power is in use.

B. Galvanic Corrosion

Galvanic corrosion results from a potential electrical difference existing between dissimilar metals immersed in a conductive solution (e.g., salt water). If these metals touch or are otherwise electrically connected, this potential difference produces an electron flow between them. The attack on the more active metal is usually increased and the attack on the less active metal is decreased, as compared to when these metals are not touching.

C. Corrosion Prevention

Anti-corrosion anodes are attached to the bottom of the gimbal housing to prevent corrosion to your stern drive and underwater parts. These anodes will be slowly eroded away by galvanic action and require periodic inspection. Please refer to the section on “Anti-Corrosion Anodes” in your engine manufacturer’s manual for additional information. The engine manual is included in the owner’s packet.

FUEL SYSTEMS

I - 1 GASOLINE FUEL SYSTEMS

Gasoline fuel systems used in Four Winns® boats are designed to meet or exceed the requirements of the U.S. Coast Guard, the National Marine Manufacturers Association, and the American Boat and Yacht Council in effect at the time of manufacture.

Tanks on Four Winns® boats are located forward of the aft bilge compartment below the floor. Below is a list of fuel tank capacities by model.

Fuel Tank Capacities

MODELS	CAPACITY
214 Funship	50 GAL/189 L
234 Funship	65 GAL/246 L
264 Funship	80 GAL/302 L

NOTICE

Use only clean fuel of the type and grade recommended by the engine manufacturer. Engine damage resulting from the use of a lower octane gasoline is considered misuse of the engine and will void the engine warranty. Refer to the section on Gasoline Requirements in the engine manual for information on octane specifications.

A. System Testing

All gasoline fuel systems have been factory inspected and pressure tested in accordance with regulations in effect at the time of manufacture. Additionally, each fuel tank must pass rigid tests and inspections performed by the fuel tank manufacturer.

Prior to taking delivery, it is important that a full inspection be made of the entire fuel system by the selling dealer. An entry on the Four Winns® Pre-Delivery Inspection Form portion of the Warranty Registration Card will attest to the dealer's performance of this service.

B. Fuel Fills

Fuel fill deck plates are located either on the aft deck or side decks, and are marked "GAS". To open, push the tab in and lift up on the cap. Be sure to utilize the proper type and grade of fuel. See Section I-3 for additional information.

The fuel fill fitting allows for venting below the fill cap. While the tank is being filled, the air displaced by the fuel escapes through the fuel fill/vent. This reduces the amount of fuel spillage. **Always** open the lid slowly to allow air to escape. See Figure I1.

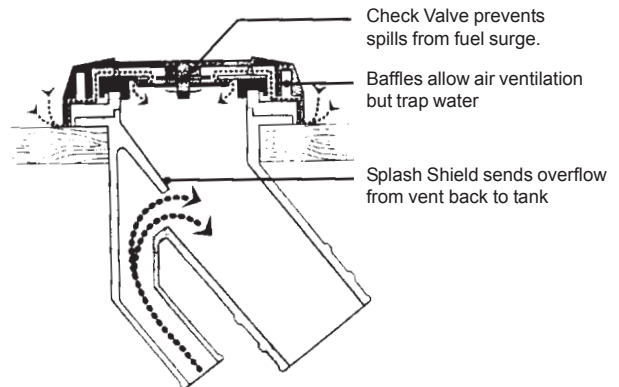

Figure I1: Fuel Fill

The gasket seal on the fuel fill cap assists in sealing when closed. A missing or damaged gasket can allow water on the surrounding surfaces to run into the tank. Periodically inspect the gasket and the fuel deck plate for damage.

WARNING

DO NOT confuse GAS deck fill plate with WATER or WASTE deck plates. Deck fill plates are labeled according to the intended use.

WARNING

Spilled fuel is a fire hazard. DO NOT overfill or overflow the tank, or allow fuel spills into the hull or bilge. If spillage occurs, clean up immediately and dispose of soiled rags/towels in a proper container.

NOTICE

When fueling at a marina, DO NOT overfill. Fuel may spill into the water.

After fueling, replace the fill cap, and wash the areas around the fuel fill plate. Residual fuel left on the deck and hull sides can be dangerous, and will yellow the fiberglass. It will also damage the tape stripes and logos.

C. Anti-Syphon Valves

The fuel withdrawal line is equipped with an anti-syphon valve where the line attaches to the fuel tank. This valve prevents gasoline from syphoning out of the fuel tank should a line rupture. See Figure I2 for anti-syphon location.

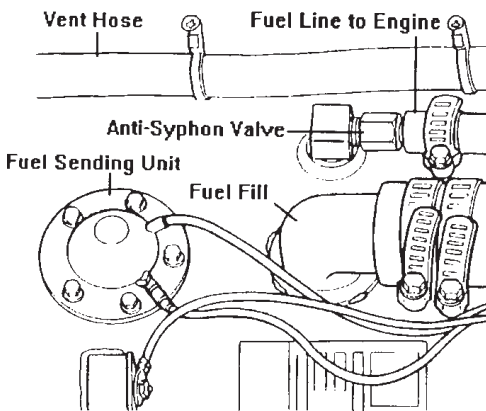

Figure I2: Fuel Tank Fittings

CAUTION

The fuel withdrawals are positioned in the fuel tanks to achieve optimum fuel usage, and fuel line routing. At certain speeds and hull trim angles, the fuel supply at the withdrawal tank location can increase or decrease accordingly. Be extremely careful when attempting to operate the boat on a minimum amount of fuel. Though some fuel may be in the tank, the relative trim angle of the boat may cause the fuel to flow away from the withdrawal.

NOTICE

Access plates or lids are provided in the floor for easier access to the fuel pick-up, anti-syphon valve and sender.

D. Fuel Gauge

The fuel gauge indicates the amount of fuel in the tank. See Section E-6F Fuel Gauge for additional information on fuel gauge use.

E. Fuel Senders

The fuel sender consists of a mechanical arm with float which measures the fuel in the tank. The sender arm adjusts with the amount of fuel in the tank and sends a signal to the fuel gauge. See Figure I3.

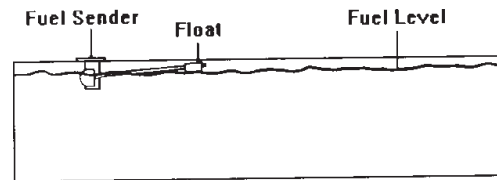

Figure I3: Fuel Sender Operation

Due to the mechanical nature of the fuel sender, variations in readings during various speeds of operation may occur. This system is merely a relative indication of the available fuel supply and not a calibrated instrument. Relative adjustments can be made by your Four Winns® dealer by bending the fuel sender float arm.

The gauge readings will also vary with the trim angle of the boat. When sitting at a dock and the boat is nearly level, the fuel gauge will register accurately. Refer to Figure I3. When boating, the trim angle of the boat changes and affects the gauge readings. Under these conditions, the fuel sender will register “full” for the first few hours of running time until the fuel level drops below the 3/4 or 1/2 mark. This is caused by the angle of the fuel in the tank as shown in Figure I4.

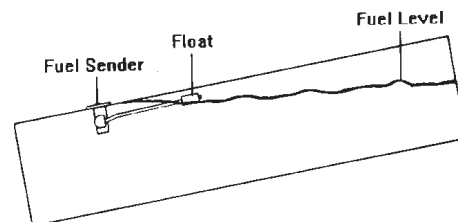

Figure I4: Effects of Trim Angle

It is very important to keep track of hours and fuel consumption to obtain an average gallon per hour consumption figure. Refer to the fuel log located at the back of this manual. This will prevent any problems with running out of fuel on the water.

Dealers are equipped with some general figures on consumption which can be used as a guide until specific information on your boat is determined. Because of boating conditions, speed, weight and other factors common to your situation, fuel consumption will vary between your boat and consumption figures developed by Four Winns®.

When the fuel gauge begins to register below the “full” mark, the gauge readings will drop much faster until it reads “empty”. When this occurs, the trim angle has affected the sender reading. When the gauge registers “empty”, the sender has bottomed out and there may be 3 to 4 gallons of fuel in the tank. See Figure I5.

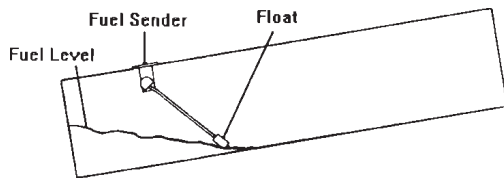

Figure I5: Trim Angle Effect with Low Fuel

F. Fuel Filters

Fuel filters are installed on each engine. Filters should be cleaned or changed frequently to assure an adequate supply of fuel to the engine. Refer to the engine manual for additional information. The engine manual is included in the owner’s information packet.

NOTICE

Canister-type filters should be changed annually.

G. Use and Maintenance

 **WARNING**

DO NOT let the odor of gasoline go unchecked. If the odor of gasoline is noted, DO NOT START ENGINE. If engine is running, SHUT OFF ENGINE, ELECTRICAL AND HEAT GENERATING EQUIPMENT. Investigate and correct the situation immediately! Have all passengers put on personal flotation devices and keep fire extinguishers at hand until the situation is resolved.

 **WARNING**

Avoid serious injury or death from fire or explosion resulting from leaking fuel. Inspect systems for leaks at least once a year.

 **WARNING**

To help guard against damage, avoid the storage or handling of gear near the fuel lines, fittings and tanks.

The warning label below is placed in areas that are large enough to accommodate a six gallon portable fuel tank.

 **WARNING**

No ventilation is provided. Fuel vapors are a fire and explosion hazard. To avoid injury or death **do not store** fuel or flammable liquids here.

I - 2 FUEL STANDARDS

Be cautious when using gasoline that contains alcohol. Refer to the section on gasoline requirements in your engine manual for additional information.

 **CAUTION**

To conform to Federal Air Quality Standards, the petroleum industry reduced the amount of tetraethyl lead in gasoline. Alcohol is being blended with gasoline to help restore the octane rating lost when the lead was removed. While blending alcohol with gasoline increases the octane level of the fuel, it can also create certain safety and performance related problems for boaters.

A. Problems With Alcohol In Gasoline

Below is a list of problems which may be experienced when using blended gasoline.

1. Premature deterioration of fuel system components may occur. Alcohol will attack rubber fuel hoses, fuel tanks, fuel filters, fuel pumps and rubber gaskets. This deterioration will lead to fuel system leakage.

2. Phase separation of fuel will cause contamination. Water which accumulates in the tank through contamination or condensation will be absorbed by the alcohol. This water-heavy alcohol will settle at the bottom of the tank. This phase separation will lead to fuel tank corrosion. This may also result in a lean mixture to the carburetor and cause engine stalling or possible engine damage.

The use of alcohol additives in gasoline has become more widespread. Regulations on public notification of the existence of additives is currently controlled by the Environmental Protection Agency (EPA). Some states do require that gasoline pumps display information on additives (especially alcohol). If alcohol content is not posted, ask and avoid using fuel containing alcohol if possible.

B. Recommendations

Assume blended gasoline is being used and follow these recommendations below.

1. Inspect fuel hoses often. A deteriorated hose containing alcohol blended gasoline will normally be soft and swollen. A deteriorating hose containing no fuel will normally be hard and brittle. In both cases the hose should be replaced.
2. Ventilate the engine compartment before starting the engine(s). Operate the engine compartment blower for four (4) minutes. Then, prior to starting the engine(s), check the bilge area for the scent of gasoline fumes; DO NOT start the engine(s) if the odor of gasoline is detected.
3. Frequently inspect the fuel system fittings. Inspect the fuel tank, pump and filter for signs of leaks or corrosion. Visually inspect for deteriorating metal fittings at the fuel hose connections.



WARNING

Avoid serious injury or death from fire or explosion resulting from leaking fuel. Inspect system for leaks at least once a year.

If areas are found within the fuel system that appear questionable, have a qualified marine technician inspect the system. A thorough fuel system examination should be made by an experienced marine technician at least once a year.

I - 3 FUELING INSTRUCTIONS

1. Avoid fueling at night except in emergencies.
2. When moored at fueling pier:
 - a. Do not smoke, strike matches, or throw switches.
 - b. Stop all engines, motors, fans, and devices that could produce sparks.
 - c. Put out all lights.
3. Before starting to fuel:
 - a. Ensure that boat is moored securely.
 - b. Be sure the proper type and grade of fuel as recommended by your Engine Owners Manual is used.
 - c. Determine how much additional fuel is required to avoid overflow.
4. During fueling:

Keep the fill nozzle in contact with the fuel opening at all times to guard against possible static spark. See Figure I6.



WARNING

Spilled fuel is a fire or explosion hazard. DO NOT overflow the tank or allow fuel spills into the hull or bilges. Avoid overboard spills. Visually monitor the fuel vent located on either the transom or side of the hull. When the tank is full, fuel will flow from the fuel vent.

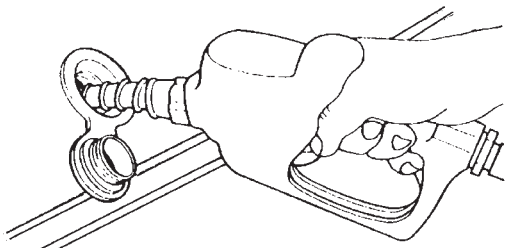

Grounding the fuel hose - Proper
(Nozzle in contact with fuel opening)

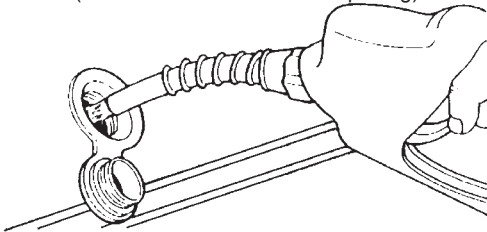

Not grounding the fuel hose - Improper
(Nozzle not in contact with fuel opening)

Figure 16: Grounding Fuel Hose

5. After fueling:
 - a. Replace all fill caps securely.
 - b. Wipe up any spilled fuel.
 - c. Determine that there is no odor of gasoline in the engine compartment or below decks before starting machinery, turning on lights or lighting stove. Operate the bilge blower system for at least four (4) minutes before engine start-up.
 - d. Be prepared to cast off moorings as soon as engine is started.

WASTE AND WATER SYSTEMS

J - 1 GENERAL

Some Four Winns® models are equipped with a fresh water supply system. This system consists of a water supply tank, water distribution lines and a distribution pump. Refer to Figure J7 at the end of this section for general water system diagram. The water fill deck plate for the fresh water system is located on the deck. Always fill the tank slowly.

The approximate location of the water fill for each model is listed below.

Water Fill Locations

MODELS	DECK WATER FILL LOCATION
214 Funship	Stbd side of deck, towards the stern.
234 Funship	Port side of deck, at the stern.
264 Funship	Port side of deck, at the stern.



CAUTION

The water deck plate is appropriately labeled. DO NOT fill the system with anything other than water. Should the system become contaminated with fuel or other toxic solution, component replacement may be necessary.

The water tank is equipped with an overboard vent. Maintain a close visual watch on the overboard vent while filling the water tank. Always fill the tank slowly. When the tank is almost full, water will spurt out of the vent.

NOTICE

When filling the tank, never seal the hose to the deck plate. The tank would become pressurized and could rupture.

The following is the capacity and location of water supply tanks.

NOTICE

DO NOT overfill the water tank. Tank damage may result. Water capacity and tank location may vary due to other equipment that may be installed on the boat.

Water Tank Capacities

MODELS	TANK CAPACITY	LOCATION
214 Funship	7 gal./26.5 l	Stbd side, in bilge compartment.
234 Funship	7 gal./26.5 l	Port side, in bilge compartment.
264 Funship	7 gal./26.5 l	Port side, in bilge compartment.

The materials from which the components of the water system are made may give the water supply a peculiar taste, especially when new. This condition is normal and can be reduced somewhat through the use of a water filter; such as that produced by Ametek®, Inc. Also, chemicals such as Sudbury's Aqua-Fresh™ and Pettibone's Aquabon™ are effective. The taste will completely dissipate in time.

J - 2 DISINFECTING THE WATER SYSTEM



CAUTION

The fresh (potable) water system should be disinfected prior to initial use.

The water system should be disinfected before first use and at the beginning of each season. The following information is a general guide to disinfecting the fresh water system.

1. Flush the boat's water system thoroughly with fresh water. Make sure all antifreeze is removed from the system.
2. The water system should be drained completely.

3. To disinfect the water system, use one gallon of water and 1/4 cup of Clorox or Purex household bleach (5% sodium hypochlorite solution). This is recommended for each 15 gallons of tank capacity.
4. Allow to stand for three (3) hours. If time is a factor, greater concentrations of chlorine solution will be needed to disinfect the water system.
5. Drain the system.
6. Flush the system thoroughly with fresh water.
7. Fill the system with fresh water.

To remove excessive chlorine taste or odor which might remain in the system, prepare a solution of one quart vinegar to five gallons water and allow this solution to agitate in the tank for several days during boating. Then drain tank and refill with fresh water.

The cockpit sinks are equipped with traps, and the water will drain slowly. If the system is not operating properly, have it checked by your authorized Four Winns dealer.

J - 3 FRESH WATER SYSTEMS

A. Integrated Sinks - 214 & 234 Funships™

The 214 Funship™ has an integrated sink and trash receptacle located in the bow area. The 234 Funship™ also has an integrated sink, trash receptacle and cooler located in the bow area. See Figures J1 and J2. The excess water from the sink will drain overboard. The water pump and water tank for the sink are located in the bilge compartment and will draw water when the switch is operated. See Figure J5. The switch to operate the water pump is located inside the enclosed head and is marked "FRESH WATER". After the tank has been filled, operate the pump switch until water comes out of the faucet. After all the air has been purged from the system and a steady flow of water is coming from the faucet, turn off the pump switch.



Figure J1: 214 Funship™ Sink & Faucet



Figure J2: 234 Funship™ Integrated Sink, Cooler & Trash Receptacle

NOTICE

If the line is routed improperly, kinked or is disconnected, the water pump may not operate properly. Inspect and correct the hose routing (if necessary). If a problem still exists, contact your Four Winns dealer for assistance.

NOTICE

DO NOT operate the pump with an empty tank. Damage to the water pump may result. Be sure the pump switch is off when not in use.

B. Refreshment Center - 264 Funship™

The 264 Funship™ comes equipped with an refreshment center located on the starboard side, behind the helm seat. The refreshment center includes a built-in ice chest, Corian® countertop, trash receptacle, sink with pressurized water, and underneath slider storage for the 36 quart removable Igloo® cooler. The switch to operate the faucet is located inside the enclosed head and marked "FRESH WATER". The same fresh water pump is utilized by both the sink and forward/transom washdowns. See Figure J3.



Figure J3: 264 Funship™ Refreshment Center

C. Forward and Aft Showers (Washdowns)

Forward and aft showers are standard on all Funship™ models. The shower system can be used for showering or washdown purposes at either the bow or transom areas. The switch to operate the washdown is located inside the enclosed head marked “Fresh Water”. See Figures J4 & J5.



Figure J4: Funship™ Transom Washdown

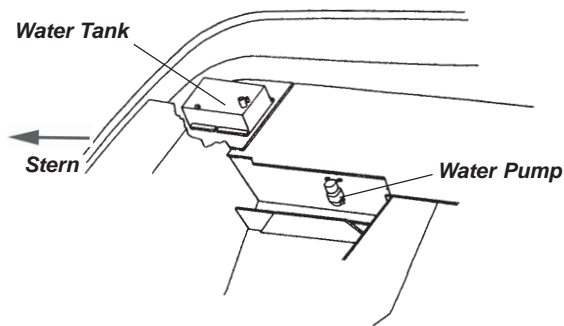

Figure J5: 234/264 Funship™ WaterTank Location

The fresh water tank has a seven gallon capacity and is located in the rear bilge compartment either on the port or starboard side of the Funship™ models. See Figure J4. The water fill deck plate is located either on the port or starboard side of the deck, near the stern of the boat. The fresh water deck fills are clearly mark “WATER”.

A fuse to protect the water pump is located in the fuseblock under the starboard helm. The pump is also located in the rear bilge compartment in close proximity to the water tank.

Models equipped with the transom and/or forward washdown will use the same fresh water pump used for the refreshment sink. With the pump switch “ON”, push the spray nozzle button to purge any air that may be in the system. When a steady flow of water is com-

ing from the washdown nozzle, release the spray nozzle. As the pressure builds, the pump will automatically shut off at 35 psi.

When properly primed and activated, the pressurized water system can be used in the same manner as the water system in a home. An automatic pressure sensor in the water pump keeps the system pressurized. Simply operate the spray nozzle and water will be delivered. If the system has been recently filled, or has not been used for an extended period of time, air bubbles may accumulate at the pump. If this should happen, re-priming may be necessary.

J - 4 HEADS

A. Funship™ Enclosed Heads

On all Funship™ models, an enclosed head is a standard feature. These roomy heads include a porta potti, overhead lighting, opening port light, removable carpet. See Figure J6.



Figure J6: Funship™ Enclosed Head

B. Pump Out Option

When equipped with the pump out option, the waste can be removed from the tank at a pumping station. A deck plate fitting labeled “WASTE”, is provided for this purpose. The pump out option is available on all Funship™ models. Most marina fueling facilities provide service for waste pump out.

To pump out the holding tank:

1. Connect the dockside pump out connection to the WASTE plate located on the deck.

NOTICE

Usually the dockside pump out connection will screw into the waste deck plate or has a rubber sleeve that inserts into the plate and must be held in position during the pump out operation.

2. Have the pumping station operator activate the pumping equipment. The waste will be drawn from the holding tank and into the pumping stations disposal tank.
3. Remove the pump out connection from the deck plate. Add 1 gallon of clean water to the holding tank through the waste deck fitting using a dockside water hose.
4. Repeat steps 1 & 2 above to pump out the water used in step 3 to flush the holding tank.
5. Add waste holding tank treatment chemical available from the dockside pumping station operator to the head. Flush at least twice.



CAUTION

Be careful when handling and storing treatment chemicals. Not only are they toxic, but they will also stain and damage surrounding surface.

It will be necessary to remove the top holding tank of the portable head to fill with water.

J - 5 SYSTEM MAINTENANCE

Be sure the batteries in the boat are properly charged. Operating the pressure pump from a battery with a low charge will result in pump cycling. This could lead to premature pump failure.



WARNING

The decomposition of waste produces a colorless, odorless gas, methane, that is lighter than air, combustible, and extremely lethal. Always provide sufficient ventilation when effecting repairs to the waste system and allow no odor from the waste system to go unresolved.

A. Clean Vents and Screens

Periodically remove the vent caps and check the water tank vent(s). Clean the thru-hull vent fitting(s) of any dirt, wax, plastic particles, etc. Always replace the caps after cleaning.

NOTICE

Failure to keep the water tank vent fitting clean will cause excessive pressure buildup within the tank during filling. This can cause water tank damage.

B. Winterizing the Water System

Winter lay-up service procedures should include a thorough draining of the water system. Disconnect all accessible fittings. Blow out all lines. Be sure the water tank, waste tank, pumps and lines are completely dry. Freezing water can cause severe damage to all water system components.

NOTICE

It may be necessary to disconnect the hose below the faucet to remove excess water in the lines to prevent freeze damage.

NOTICE

Always winterize the fresh water system prior to winterization of the hull drainage (bilge pump) system.

Draining the system as mentioned can be very tedious and an incomplete job can result in expensive repairs. The use of nontoxic antifreeze (such as R.V. antifreeze) designed for fresh water systems considerably reduces the work necessary and is a more positive means of winterizing the system. Follow the directions included with the antifreeze solution.

To winterize:

1. Turn on the water pump/faucet and drain the water tank. The water tanks on some models can be drained by removing the withdrawal hose from the tank and allowing water to drain into the bilge.

NOTICE

DO NOT run the water pump without water in the system. Pump damage can result. Be watchful and turn the pump off as soon as the tank becomes empty.

2. Add 1/2 gallon of R.V. antifreeze to the water tank.
3. Turn ON the pump until undiluted antifreeze is seen.



DANGER

Use only nontoxic antifreeze solutions such as R.V. antifreeze. DO NOT use ethylene glycol solutions; the type that is used in engine coolant systems. These are toxic.

NOTICE

Be sure to wipe up any antifreeze that has been spilled on the fiberglass surfaces to prevent possible discoloration or damage to the gel coat.

Depending upon options and model, additional information by the equipment manufacturers is included in the owner's packet. Also, refer to Section R for Maintenance.

WATER SYSTEM

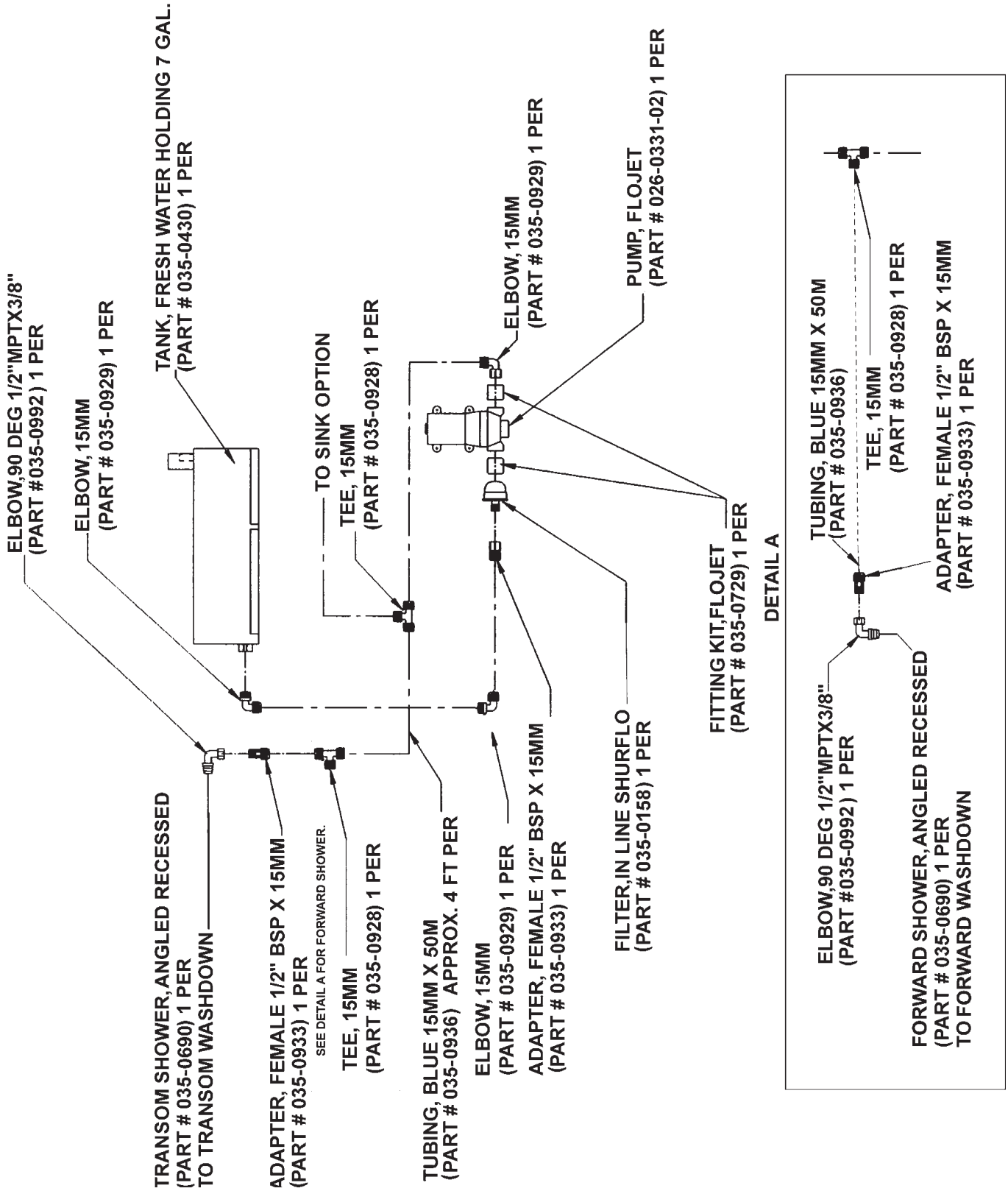

Figure J7: General Water System Diagram

VENTILATION & DRAINAGE SYSTEMS

K - 1 ENGINE COMPARTMENT VENTILATION

All Four Winns® stern drive models are equipped with engine compartment ventilation. This system is designed to meet or exceed the requirements (in effect at the time of manufacture) of the U.S. Coast Guard, the National Marine Manufacturers Association, and the American Boat and Yacht Council.

A. Gravity Ventilation System

This system includes air intake and exhaust components. The exhaust ducting reaches to the lower bilge area. This provides adequate air movement while underway and during bilge blower operation.

B. Forced Air Ventilation

All Four Winns® models except outboards are equipped with an electric bilge blower. The bilge blower provides the ventilation required prior to starting the engines and while at idle. See Section H Electrical Systems for blower operation instructions.



WARNING

Gasoline vapors can explode resulting in injury or death. Before starting the engine, check the engine compartment bilge for gasoline or vapors, and operate blower for four (4) minutes, and verify blower operation. Run blower when vessel is operating below cruising speed. ALWAYS operate the bilge blower while the engines are at idle.

C. Engine Ventilation System Maintenance

Periodic inspection and cleaning of the ventilation ducts is necessary to ensure adequate air circulation. A buildup of leaves, twigs, or other debris can severely reduce ventilation. Be sure bilge water does not accumulate to a level that would obstruct the ventilation ducts.

Blower operation can be tested by placing a hand over the vents. DO NOT rely on the sound of the blower. Be sure a substantial amount of air is being exhausted by the bilge blower. Check the bilge blower system often, preferably before each cruise.

Should blower noise and vibration be excessive, loosening the bilge blower mounting screws and then tightening evenly usually reduces noise considerably.

K - 2 HULL DRAINAGE SYSTEMS

A. Transom Drain

A transom drain with plug is provided in the engine compartment to allow water drainage. When the boat is out of the water, the boat and trailer should be positioned so any bilge water accumulation during dry storage will flow towards the transom.



CAUTION

Be sure the drain plug is securely in place prior to launching the boat. Upon shipment of the boat, the drain plug is usually taped to the steering wheel.

B. Bilge Pumps

Bilge pumps are provided in the bottom of the hull to remove miscellaneous water accumulations that might occur during normal boating or weather conditions. The bilge pump is controlled by the Bilge Pump Switch on the dash panel. See Section H-3 for a detailed description of the bilge pump switches.

Bilge pumps equipped with automatic switches are standard on all Funship™ models. As the water level rises, the automatic float switch will activate the pump.

When leaving the boat unattended for long periods of time or during excessive rain storms, it is a good idea to check on the boat for excessive water accumulation. Be sure both the bilge pump and automatic float switch are operating properly. The operating time of the bilge pump will be limited to the battery capacity.

NOTICE

While at rest, any bilge water accumulation may flow forward. Therefore, operate the bilge pump shortly after getting underway and while the boat is at a substantial running angle. DO NOT allow bilge water to accumulate. Damage to the engine or other components may result.

Periodically, clean the bilge pump strainers. DO NOT allow dirt and debris to clog the bilge pump intakes. Check operation of the bilge pump float switch often to ensure movement of the switch is not restricted by debris, portions of the hull, etc.

Wipe up any oil accumulation in the bilge prior to activation of the bilge pump. Pumping oil overboard will pollute the water, and is subject to fine.

After winterization of the fresh water systems, be sure the bilge area, bilge pump and associated hoses are thoroughly dry. Damage to the hull, bilge pump and other equipment could occur if water is allowed to freeze in the bilge.

C. Liner Drains

Liner drains are provided on models with fiberglass liners or floors. Fiberglass liners can be cleaned easily by hosing the floor. The water will drain into the bilge and be pumped overboard.

D. Bilge Compartment Drainage

Certain bulkhead areas of Four Winns® boats are sealed in accordance with U.S. Coast Guard regulations effective at the date of manufacture. Drainage is provided and water can be removed with the bilge pump.

INTERIOR EQUIPMENT

L - 1 INTEGRATED SINK - 214 FUNSHIP™

The 214 Funship™ has an integrated sink and trash receptacle located in the bow area. The excess water from the sink will drain overboard. The lid for the trash receptacle consists of Corian® material and includes a finger-pull to allow easy access. See Figure L1.



Trash Receptacle Lid

Sink & Faucet

Figure L1: 214 Funship™ Integrated Sink & Trash Receptacle

L - 2 INTEGRATED SINK & COOLER- 234 FS

The 234 Funship™ has an integrated sink, trash receptacle and cooler located in the bow area. The excess water from the sink and cooler will drain overboard. The cooler lid and countertop consists of Corian® material and includes a finger-pull in the cooler lid to allow easy access. See Figure L2.



Trash Receptacle

Sink & Faucet

Cooler

Figure L2: 234 Funship™ Integrated Sink, Cooler & Trash Receptacle

L - 3 BUILT-IN ICE CHESTS

The Funships™ have a built-in ice chest located in the bow, underneath the center bow cushion. Along with the integrated ice chest, a 36 quart removable cooler(s) is included. The cooler can be stored beneath the port hinging seat for the Funship™ models. The 264's second removable cooler can also be stored in a specially designed cooler slider insert underneath the entertainment center. See Figure L3 & L4. The 234 FS also has another built in ice chest/storage compartment located between the two bucket seats.



Removable Cooler

Figure L3: 214/234 Funship™ Cooler Storage



Removable Cooler

Figure L4: 264 Funship™ Cooler Storage

L - 4 REFRESHMENT CENTER - 264 FUNSHIP™

The 264 Funship™ comes equipped with an refreshment center located on the starboard side, behind the helm seat. The refreshment center includes a built-in ice chest, Corian® countertop, trash receptacle, sink with pressurized water, and underneath slider storage for the 36 quart removable Igloo™ cooler. See Figure L5 and Section J-3B for more details.



Figure L5: 264 Funship™ Refreshment Center

L - 5 HEADS

On all Funship™ models, an enclosed head located in the port console is standard. These roomy heads offer overhead lighting, opening port light with screen, and porta-potti. See Figure L6.



Figure L6: Funship™ Enclosed Head

L - 6 STEREO

Four Winns offers a CD stereo as standard equipment on the all of the Funships™. The stereo includes a removable face and remote display at the helm. The stereo is mounted on the starboard console, at the walk-thru area, above the storage compartment door. The stereo is placed inside a plastic box to help protect it from the elements. The radio box has a sliding door to allow access to the controls. For stereo operation, please

refer to the manufacturer's manual included in the owner's information packet.

The speakers are installed within the side bulkheads or seat bases.

For additional information on stereos, refer to Section H-3C of this manual and the manufacturer's literature included in the owner's packet.

L - 7 BURLWOOD HELM ENHANCEMENTS

A standard feature on the Funship™ models is the burlwood wood grain accent. This consists of finished synthetic mahogany for the instrument panel and ignition switch panel. For care and upkeep information, refer to Section Q-3 Burlwood Mahogany in this manual.

L - 8 ANCHOR/LADDER STORAGE

The Funship™ models have a built-in anchor/ladder locker. It is located at the bow of the boat. Simply lift the anchor lid to gain access to the anchor/ladder locker. The ladder located inside is a 4-step ladder which provides a deep-reach and allows for easier boarding. The anchor/ladder lid provides hand holds that make boarding easier. See Figure L7 below and Section M-1D for additional information.



Figure L7: Bow Ladder

L - 9 IN-FLOOR STORAGE LOCKER

A standard feature on all Funships™ is an in-floor storage locker. The 264 Funship™ has two. The locker(s) allows for storage of skis, tow ropes, personal floatation devices, etc. The storage lid(s) is hinged and includes a gas assist shock for ease of use. The lid is design to stay in place in choppy water. See Figure L8.



Figure L8: Funship™ In-Floor Storage Locker

L - 10 BOW STORAGE

The port and starboard bow seat cushions are removable on all Funship™ models. Underneath each cushion is additional storage for all types of gear.

L - 11 BOW FILL-IN CUSHIONS

Utilizing the standard bow fill-in cushions you can turn the bow of your Funship™ into a sundeck. These bow fill-in cushions can be easily removed or installed in a matter of minutes. The bow cushions may be stored in the in the starboard storage locker. See Figure L9.



Figure L9: Funship™ Bow Fill-In Cushions

L - 12 STERN SEAT STORAGE

Additional storage space is provided under the stern seating area. This allows you to store necessary equipment without taking up usable space. See Figure L10.



Figure L10: Stern Seat Storage

L - 13 STARBOARD CONSOLE STORAGE LOCKER

The Funships™ feature a starboard console storage locker. The storage locker provides the storage space needed for all the essentials one needs to make an all day boating adventure a success. See Figure L11.



Figure L11: Starboard Console Storage

L - 14 SWIM PLATFORM - LADDER

Four Winns provides an integrated fiberglass swim platform fore and aft on all Funship™ models. For better footing, a skid-resistant surface is provided. The swim platform is recessed for the ladder and a hinging ladder lid is provided. With this design, the ladder is concealed and you do not lose valuable platform space.

The ladder is “deep” and “angled” mounted which makes it easier to climb. The stern ladder’s starboard location means you’re not approaching a down skier on your “blind side”.

WARNING

Keep hands and fingers away from ladder hinges to prevent injury.

WARNING

Never approach or use ladder when the motor is running. Severe injury or death will result from contact with rotating propeller.

WARNING

Shut off motor when near swimmers. Severe injury or death will result from contact with rotating propeller.

NOTICE

Always secure the ladder before boating. Damage to the ladder may otherwise result.

WARNING

Prevent falls overboard. Secure transom walk-thru backrest and stay inside cockpit while underway.

WARNING

To prevent personal injury, swim platform must not be occupied and transom walk-thru backrest door must be in place while engines are running.

CAUTION

To prevent personal injury, DO NOT sit on the transom walk-thru backrest door.

L - 15 TRANSOM WALK-THRU BACKREST DOOR

A transom walk-thru backrest door is removable to allow easy access from the swim platform to the cockpit. To secure the backrest walk-thru door to the transom, simply slide it between the two sets of cleats. To prevent a possible man overboard situation, make sure the transom walk-thru backrest door is in place before each cruise. See Figure L12.

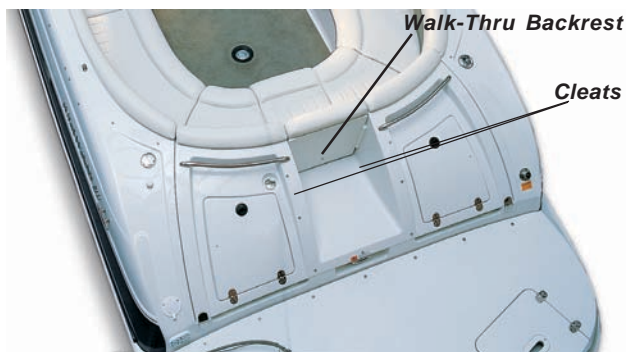

Figure L12: Transom Walk-Thru Backrest Door

L - 16 WALK-THRU DOORS

Walk-thru doors are standard features on the Funship™ models. The walk-thru doors are designed to keep out the wind and weather, making for a warmer cockpit area. See Figure L13.



Figure L13: Walk-Thru Doors

EXTERIOR EQUIPMENT

M - 1 RAILS & DECK HARDWARE

A. Rails

Grab handles have been installed to provide security for passengers in the cockpit. Limiting passenger movement while underway is recommended. All those on board should be safely seated whenever possible. Additional care must be taken when in rough seas or foul weather.

The rail system and hardware fittings have been selected and installed to perform specific functions. Fenders or mooring lines should not be secured to the rails or stanchions. Be certain that a clear lead exists when running dock lines or an anchor line. A line inadvertently threaded around a stanchion or over the rail could cause damage.

B. Cleats

The cleats that have been installed are specifically designed and are intended to be used as mooring cleats. Their purpose is for securing the vessel to a dock, pier, mooring, or anchor.



WARNING

Four Winns® Boats are not equipped with any hardware designed for towing purposes. The mooring cleats that are installed on the boat are not to be used for towing another vessel or having the boat towed. Refer to Section A Operation for additional precautions regarding grounding and towing.

C. Transom Ski Tow

The transom ski tow is mounted on the transom above the integrated platform. It is available on all Funship™ models. All these models should pull up two skiers under normal boating conditions. However, Four Winns recommends no more than two skiers be pulled behind the boat at any time.



WARNING

Do not use ski tow fitting for lifting or parasailing. Fitting could pull out of deck resulting in serious injury or death.



WARNING

To prevent personal injury or damage to the boat, DO NOT tow more than two water skiers with the transom mounted ski tow ring.

NOTICE

Skier's weight, boating conditions, amount of gear, and operator's experience will affect the number of skiers which can be pulled.

D. Anchor/Ladder Locker

The Funship™ models have a built-in anchor/ladder locker. It is located at the bow of the boat. Simply lift the anchor/ladder lid to gain access to the anchor locker. The compartment should be inspected after each use, and kept clean of dirt and debris to prevent plugging of the drain hole. For information on anchors, refer to Section M-5.

E. Maintenance

The majority of the hardware installed is made of stainless steel. Regardless of the type of hardware used, periodic maintenance is necessary.

The manufacturer of our hardware recommends the following when washing your boat:

1. Rinse the hardware with fresh water after each exposure to saltwater.
2. Periodically wash the hardware with mild soap, warm water, and a sponge. Then dry it with a soft cloth.
3. Avoid cleaners, abrasives, waxes, and most of all, do not use steel wool.

NOTICE

All fittings must be periodically inspected for loosening, wear, and damage. Problems should be corrected immediately!

M - 2 WINDSHIELDS

The windshield on all Funship™ models is standard equipment. The windshield consists of tempered safety glass and the windshield frame consists of a powder coated aluminum. For easy accessibility to and from the bow, a walk-thru center windshield is standard. Stainless steel supports or braces are used in all of the windshield assemblies.

CAUTION

We recommend you close and secure the walk-thru windshield while underway. Damage to the windshield could result.

CAUTION

Secure windshield with strap when in open position. Securing the walk-thru windshield will help prevent the windshield from accidentally slamming closed due to high wind and/or wake condition, thus reducing the chance of damage to windshield or injury.

Windshields made of tempered glass can be cleaned with automotive glass cleaners or dishwashing soap and water. Use a clean cloth to prevent scratching the glass.

Aluminum can be cleaned with similar products or with nonabrasive cleaners such as Fantastik™.

NOTICE

Read the label before using any product. DO NOT use abrasive cleaners.

M - 3 EXTENDED SWIM PLATFORM - LADDER

Four Winns provides an extended fiberglass swim platform on all Funship™ models. The platform extends the existing swim platform creating more space for water sport activities. Just like the integrated swim platform the extended swim platform has a skid-resistant surface. The swim platform is recessed for the ladder and a hinging ladder lid is provided. With this design, the ladder is concealed and you do not lose valuable platform space. In addition, a hand hold has been placed in the ladder lid to assist in boarding. See Figure M1.



Figure M1: Extended Swim Platform

The ladder is “deep” and “angled” mounted which makes it easier to climb. Its starboard location means you’re not approaching a down skier on your “blind side”.

WARNING

Keep hands and fingers away from ladder hinges to prevent injury.

WARNING

Never approach or use ladder when the motor is running. Severe injury or death will result from contact with rotating propeller.

WARNING

Shut off motor when near swimmers. Severe injury or death will result from contact with rotating propeller.

NOTICE

Always secure the ladder before boating. Damage to the ladder may otherwise result.

M - 4 TRANSOM WALK-THRU BACKREST DOOR

A transom walk-thru backrest door is removeable to allow easy access from the swim platform to the cockpit. To secure the backrest walk-thru door to the transom, simply slide it between the two sets of cleats. To prevent a possible man overboard situation, make sure the transom walk-thru backrest door is in place before each cruise. See Figure M2.



Figure M2: Transom Walk-Thru Backrest Door



WARNING

Prevent falls overboard. Secure transom walk-thru backrest and stay inside cockpit while underway.



WARNING

To prevent personal injury, swim platform must not be occupied and transom walk-thru backrest door must be in place while engines are running.



CAUTION

To prevent personal injury, DO NOT sit on the transom walk-thru backrest door.

M - 5 ANCHOR & ANCHORING

Anchors are available in different shapes, sizes and weights to fit different boats, uses, and conditions. The weight of the anchor and diameter of anchor line should be governed by the size and weight of your boat. Four Winns recommends a “Danforth style” 8 pound, Attwood® “Penetrating” anchor, with a 3/8” line be used on all the Funship™ models. The recommended line length is 100-150 feet. Because of differences in style, a larger anchor may be needed for different bottom or boating conditions. Your Four Winns dealer can tell you which anchor will work best for your boat.

Keep anchor secure while underway to prevent damage or injury due to sudden shifting in the boat’s attitude.

Use two or more anchors if anchoring overnight or for extended periods. If not using two anchors, make cer-

tain there is sufficient clearance for your boat to swing in a full circle to prevent damage in case of shifting winds.

Make certain you have enough anchor line (or scope) for the depth of water. Your anchor line should be 6 to 7 times the depth of water anchored in. For example, if you are in 20 feet of water, use 120 to 140 feet of anchor line.



CAUTION

Secure anchor line to bow eye or deck cleat. Never tie anchor line to a rail, rail fitting or other hardware not designed to support this stress.

To drop anchor:

Approach your selected anchoring site from downwind and come to a dead stop over the spot where you want to drop anchor. Lower the anchor. Lower the anchor.

Maneuver the boat slowly backwards until length of anchor line is 6 or 7 times the depth of the water.

Fasten the anchor line around the bow eye or deck cleat. Anchor flukes should dig in and catch. Watch for anchor drag by checking shoreline landmarks at the time the anchor is dropped and one-half hour later. If the boat has drifted away from these reference marks, the anchor is dragging and must be reset.

To weigh anchor:

Start the engine running before pulling in anchor.

Slowly maneuver the boat forward to reduce tension on the line and make retrieval of the anchor line easier. Raise and secure the anchor.



WARNING

Always be sure to raise and secure the anchor prior to operating your boat. Failure to raise and secure anchor before getting underway could result in severe injury or damage to boat from rebounding anchor.

If the anchor becomes stuck, attach the vertical line to the mooring cleat. Wave action on the bow may lift flukes from the bottom and free the anchor. If the anchor is still stuck, feed out a few feet of line and attach it to the bow cleat. Maneuver the boat around the anchor, keeping the line firm. Determine the angle that will work to pull the anchor free.

Anchors are usually a dealer installed option. Please check with your Four Winns dealer for recommendations.

M - 6 DEPTHSOUNDER

The depthsounder is standard equipment on all the Funship™ models. The depthsounder has both audible and visual alarms. See Sections E-6H of this manual for additional information.



WARNING

Do not rely on depthsounder to avoid submerged objects. Depth sounders provide a relative indication of water depth only.

NOTICE

DO NOT depend solely upon the depthsounder for water depth. It is important to have navigational charts of the waters in which you are operating.

M - 7 TRANSOM STORAGE

Transom storage is standard on the Funship™ models. The transom storage provides storage for dock fenders and other equipment. The latches are flush mounted to prevent injury or accidental opening while underway. To open, lift the handle. See Figures M3 & M4.



Figure M3: 214 Funship™ Transom Storage



Figure M4: 234/264 Funship™ Transom Storage

UPHOLSTERY

N - 1 EXTERIOR SEATING

A. Cockpit Tables

The Four Winns “Signature” cockpit table with mount (displayed in Figure N1) is standard equipment on all Funship™ models. Table bases are “flush” mounted for convenience and safety. Table legs are removable for easy storage. To remove the table leg, simply unscrew or unlock the leg from the floor and table mounts.

B. Bow Table - Optional

An optional bow table is available on all Funship™ models. The 214 Funship™ bow table provides convenient table space in the bow area. It works in the same manner as does the aft cockpit table. The table leg can be easily removed from the floor and table mounts for easy storage. See Figure N1.



Figure N1: 214 Funship™ Forward/Bow Table

The 234 and 264 Funships™ utilize a special mounting bracket. This bracket allows for the positioning of the table as desired. The table may also be folded down out of the way when not in use, or can be easily removed from the mounting plate and stored altogether. See Figure N2.

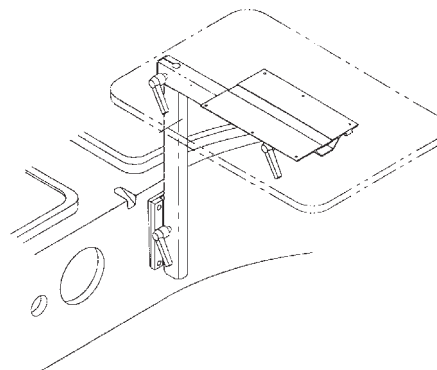

Figure N2: 234 & 264 Funship™ Bow Table

C. Bow Seating

Bow seating is provided on the Funship™ models. The cushions are removable for accessing the storage areas below. See Figure N3.



Figure N3: Funship™ Bow Seat Storage

Bow fill-in cushions are either standard or optional depending on the Funship™ model and year. Please consult with your Four Winns dealer regarding availability for your particular model.

When installed, the fill-in cushions help form a sundeck across the bow area. These cushions may be stored in the walk-thru storage or head areas. See Figure N4.



Figure N4: Funship™ Fill-In Cushions

D. Bucket Seats

The bucket seats or captain's chairs are adjustable. To adjust, lift up on the seat adjustment lever under the seat. Slide the seat forward or aft to the desired position. The seat will adjust approximately six (6) inches. See Figure N5.



Lift adjustment lever up to move forward and back.

Figure N5: Bucket Seat Slider

The driver's side and the port side can swivel and face the stern of the boat. When pulling a water skier, this permits the spotter to be in the proper position to observe.

The bucket seat also comes standard with flip-up bolster. By simply flipping up the bolster the driver is able to sit higher in the seat. This is designed to give the driver greater flexibility, increased visibility, and riding comfort.

NOTICE

The bucket seats may or may not rotate completely 180°. The amount and direction of swivel available depends on the model you have.

NOTICE

When rotating the bucket seat, damage to seat, steering wheel (if applicable), and/or coaming pad may result if attempting to rotate in the wrong direction or over-rotating. DO NOT USE FORCE to rotate the chair.

To rotate the bucket seat to face the aft position:

1. Tilt the steering wheel (if applicable) as far forward as possible.
2. Slide the seat completely forward or rearward (as needed to clear coaming/side pad or seat cushion) by using the lever located underneath the seat. See Figure N5.
3. Locate the lever on the right side of the bucket slider mechanism and lift upward to release the pin from the pedestal. This will allow you to rotate the seat. See Figure N6.
4. Rotate the bucket seat inboard (towards the center of the boat) until it faces as far aft as possible or desired. Once in position, push down on locking lever to lock seat in position. See Figure N7.

WARNING

After rotating, lock seat in place securely. Sudden acceleration with seat unlocked could cause loss of balance and possible injury.

Pull lever to up position to rotate seat.



Friction Adjustment Knob

Figure N6: Swivel Position

Once in desired position push lever down to lock seat in place.



Figure N7: Locking Position

To return the bucket seat to the bow facing position:

1. Slide the seat completely forward or rearward (as needed to clear coaming/side pad or seat cushion) by using the lever located underneath the seat. See Figure N5.
2. Locate the lever on the right side of the bucket slider mechanism and lift upward to release the pin from the pedestal. This will allow you to rotate the seat. See Figure N6.
3. Rotate the bucket seat inboard until it is in the forward facing position. Once in position, push down on locking lever to lock seat in position. See Figure N7. In addition, **DO NOT USE FORCE** to rotate the chair.
4. Position the seat forward or aft according to the needs of the individual by using the lever located underneath the seat. See Figure M5.
5. Tilt the steering wheel (if applicable) to the desired position using the tilt lever knob on the steering column.

 **WARNING**

DO NOT sit on the backrest portion of any cockpit seat. The operator could lose control of boat or passengers could be thrown from boat. Also, the seat may be damaged from improper use.

E. U - Shaped Lounger Seating

U-shaped seating is found in the Funship™ models. Large amounts of storage space are located under either the removeable seat cushions (214) or the hinged seat cushions (234 & 264).

F. Motorhood (Engine Hatch)

The motorhood is incorporated in the U-shaped seating arrangement. To gain access to the engine follow the instructions listed:

1. The Funship™ models feature a motorhood or engine hatch with an electric screw jack. The screw jack lifts and lowers the engine hatch by pressing the switch located on the dash. The screw jack runs off the boat's battery. The prop rod should **always** be utilized to help support the weight of the engine hatch and to provide added safety while working on the engine. See Figure N8.



Figure N8: 214 Funship™ Electric Motorhood Lift

To raise the engine hatch:

1. Press the engine hatch switch or manually raise the engine hood to its open position.

NOTICE

The motorhood can not be manually closed when the electric motorhood lift was used to raise the motorhood. You must also use the electric motorhood lift to lower the motorhood.

 **CAUTION**

The engine hatch can be lifted and lowered without the screw jack. Use care and proper lifting techniques to prevent possible back injury.

2. Place the prop rod into the u-shape holder in the hatch and lower the hatch so the prop rod supports the hatch. Note: Ensure you lower the screw jack enough to allow the engine hatch to rest on the rod.

 **CAUTION**

Always use the engine hatch's prop rod when working on the engine. This provides added safety while helping to prolong the life of the screw jack and engine hatch.

NOTICE

Never operate or trailer your boat with the engine hatch in its open position. Doing so could result in damage to the engine hatch, hardware, and/or loss of cushions.

NOTICE

If manually lowering the motorhood, do not allow the motorhood to "slam" shut. Gently guide the motorbox into the "closed" position. Allowing the motorbox to "slam" shut can damage the fiberglass motorbox.

NOTICE

Never operate your boat with the engine lid in its open position. Doing so could result in damage or loss of cushion and hardware. This is also true when trailering your boat. **Cushions, if not properly stored and secure, will blow out of the boat.**

N - 2 EXTERIOR UPHOLSTERY CARE

The vinyl material used on the exterior upholstery can be easily cleaned using mild detergent and water. Be sure to thoroughly rinse the seats after washing to remove all soap film. Periodic spraying of the seats with Lysol Spray Disinfectant™ will help retard mildew.

NOTICE

DO NOT apply vinyl protectants such as Armorall™. The manufacturer does not recommend this product because it removes the oils present in vinyl that keeps vinyl soft.

A recommended “Cleaning Kit” includes:

- Ivory Dishwashing Liquid™ and water
- Clean, white towels
- Medium-soft brush
- Fantastik Spray Cleaner™
- Denatured Alcohol
- Tough Duty Cleaner™
(to locate the nearest distributor, call 800-537-8990)
- Ammonia and hydrogen peroxide

To remove stains, follow the guidelines below.

1. Basic Stains/Grease/Pencil/Dirt:

Ivory Soap™ and water or Fantastik Spray Cleaner™ applied with a medium-soft brush.

2. Tough Stains/Adhesive/Teak Oil/Rust:

Tough Duty Cleaner™, rinse with soap and water.

NOTICE

To prevent possible damage to the vinyl, rinse with soap and water after applying the Tough Duty Cleaner™.

3. Ink:

Denatured alcohol.

4. Mildew Stains:

To kill bacteria creating the mildew, vigorously brush the stained area with a 4 to 1 mixture of water and ammonia; rinse with water.

5. Tough Mildew Stains:

Apply a mixture of one (1) teaspoon ammonia, one-fourth (1/4) cup of hydrogen peroxide, and three-fourths (3/4) cup of distilled water; rinse with water.

NOTICE

ALWAYS CLEAN STAINS IMMEDIATELY! DO NOT use 409 Cleaner™ or Armorall™ on vinyl. All cleaning methods must be followed by a thorough rinse with water.

Certain household cleaners, powdered abrasives, steel wool and industrial cleaners can cause damage and discoloration and are not recommended. Dry cleaning fluids and lacquer solvent should not be used as they will remove the printed pattern and gloss. Waxes should be used with caution. May contain dyes or solvents that can permanently damage the protective coating.

Additional cleaning information is provided by the manufacturer and is included with this manual.

Four Winns offers a variety of optional weather covers for protection of the boat and associated equipment. Continued exposure can damage the upholstery and seating. The seating can become thoroughly saturated with water if not adequately protected. Refer to Section O on Weather Covers for more information.

NOTICE

The appearance and longevity of the exterior upholstery will be affected by water saturation. Protect these items appropriately.

N - 3 REPLACEMENT UPHOLSTERY

Should upholstery become severely soiled, torn, or in some manner damaged, replacement upholstery cushions are available. Larger upholstery items have separate component parts for easier serviceability.

Depending upon the year and model of the boat, most upholstery parts can be obtained through your Four Winns servicing dealer within a short period of time.

N - 4 CARPET CARE

A. Interior and Exterior Carpet

The Funship™ models use a high quality exterior grade carpeting with rubber-type backing in the cockpit. Vacuuming and occasional rug shampooing are recommended for extended life and appearance. The snap-in carpet is 100% UV stabilized Olefin™ Polypropylene fiber.

NOTICE
DO NOT dry carpeting in an automatic dryer.

The snap-in carpet may be periodically washed with mild laundry soaps or shampooed, dried and reinstalled. Additional information is listed below.

B. Cleaning and Maintenance

The following information should be useful in helping you keep your carpet looking well maintained.

Carpet made with Olefin™ fiber possesses built-in stain and soil release for easy, less costly maintenance. Regular vacuuming and occasional shampooing help it stay attractive and serviceable.

C. Stain Removal Testing

Even the most stubborn stains can be removed from Olefin™ fiber following the procedures outlined. A total of thirty-four stains were selected as being representative of spills commonly occurring on carpets. Stains were pressed into the carpet to simulate foot pressure following a spill. Stains were applied to a two-inch square section and allowed to penetrate. Removal was performed after two weeks. Carpets were tested for stain removal by an independent laboratory. Stain removal was effective for all 34 stains. Results are shown in the table.

D. Stain Removal Procedure

Regular maintenance such as vacuuming, hosing or washing should be performed. Most stains and mildew are easily removed from carpet made with Olefin™ fiber using common household cleaners. Refer to Table I. Olefin™ fiber is so resistant to chemical attack that Clorox Bleach™ may be used to clean up any mildew that may result from excessive wetness.

Code for stain removal procedure (See Table 1):

“A” Apply hot water and detergent.

“B” Apply volatile dry solvent, work with bone spatula, blot.

“C” Flush by hot water extraction.

Recommended reagents:

- Carpet detergent such as Mintex™ (Hydromaster®) or any carpet detergent suitable for hot water extraction.
- Volatile dry solvent such as Carbona™, Energene™, or Picrin™ (Street®).
- Oily type paint remover such as nail polish remover, Energene™ or Pyrotex™ (Street®).
- Neutral lubricant such as Streetex Spray Spotter™ (Street®) or alternate treatment with detergent and Energene™.

STAIN	REMOVAL PROCEDURE
Automotive Grease	A
Automotive Oil (New or Used)	A
Bacon Grease	A
Berry Stain	A
Blood	A
Butter	A
Catsup or Mustard	A
Chewing Gum	A, B (Repeat)
Chlorine Bleach (5%)	A
Chocolate (Melted)	A
Clay (Red)	A
Coffee or Tea	A
Cola	A
Crayon	A, B, C
Egg	A
Feces	A
French Dressing	A
Furniture Polish	A
Grape Juice	A
Gravy	A
Ink (Permanent Black)	A, B, C
Ink (Scripto, Ballpoint)	A, B, C
Iron Rust	A
Lipstick	A, B
Mayonnaise	A
Milk	A
Shaving Cream or Lotion	A
Urine	A
Vomit	A
Wine	A

Table I: Stain Removal

WEATHER COVERS

O - 1 GENERAL INFORMATION

Weather covers for the cockpit areas are available on all Funship™ models. Four Winns covers are designed and intended to provide protection of the cockpit seating areas.

Four Winns utilizes acrylic-type material for all its covers. All Funship™ canvas except mooring covers consist of 100% acrylic material and is color matched to the boat. The mooring covers are made of 10 ounce acrylic and come in dark tan (mica) only.

WARNING

Never use any form of open flame cooking device while under, in any area fully enclosed, or near any acrylic weather cover. This material is flammable.

During the manufacture of the weather covers, the smallest possible needle and highest quality UV stabilized, bonded polyester thread is used in the stitching.

The weather cover is water repellent but not water proof. During a hard rain, you may notice a light mist permeating through a weather cover. This is normal. If the seams leak, they can be sprayed with Scotchguard™ or similar water repellent or a seam sealing compound can be applied. Keep objects from contacting the inside of the cover. Leakage may occur at point of contact.

Weather covers must be installed taut or will be damaged by accumulation of rain water.

NOTICE

Periodically check weather covers for accumulation of water. Damage to the bow assemblies may otherwise result. Make sure cover is taut to avoid puddling of water.

After use, the top canvas should be rolled up into the boot (if supplied) and secured.

NOTICE

NEVER fold or store a wet weather cover. This can lead to mildew or shrinkage. Roll rather than fold the enclosure curtains. Sharp folds increase the chance of cracking the clear vinyl.

NOTICE

DO NOT use the weather covers for outdoor winter storage. The weight of the snow or heavy rain can cause severe damage to the material or top structure. Refer to O-3 Winter Storage in this manual for more information.

When snapping covers to the boat, apply direct downward pressure on the snap. When unsnapping, rotate the snap and cover upward at each snap location.

NOTICE

Remove snaps one at a time to prevent damage. DO NOT rip off or pull the weather cover as a whole; acrylic material may tear at snaps.

A. Bimini Top (Aft/Main)

A bimini top is standard on all the Funship™ models. This style is a “freestanding” top and supported only by the bow assembly. Refer to Figures O1 & O2.

To install:

1. Attach the bimini main bow to the deck mounts.
2. Attach the forward nylon straps (214FS) or the brace rods (234/264FS) to the strap eyes or deck mounts located on the deck respectively.

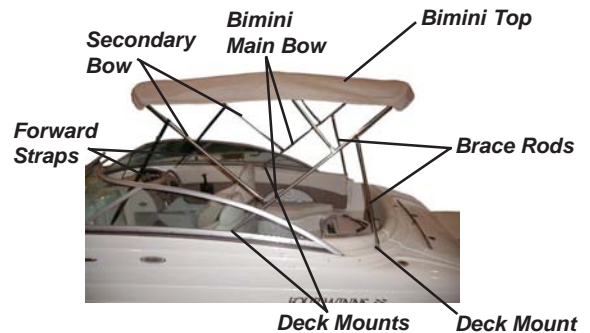

Figure O1: 214 FS Bimini Top

3. Attach the brace rods to the stern deck mounts.
4. Adjust the straps (214 FS) for tautness.

You may choose to run your Funship™ with the bimini top either fully deployed or folded together (closed) and secured with the boot provided. Either way it is designed to remain mounted. No storage is provided for this top in your boat.

NOTICE

Use two people to remove the bimini top (winter storage). This will help minimize the risk of injury and help prevent damage to the upholstery, the bimini top, and/or the boat.

NOTICE

Aft/Main bimini canvas deployment should only be utilized at or below moderate cruising speed (approximately 0-40 mph). Avoid full throttle operation of boat while having canvas deployed. Four Winns recommends booting the canvas before running at or close to maximum speed. In so doing you will help to maintain the life of the canvas and hardware. Also, the wind should be taken into consideration when determining operating speed with canvas deployed. The boat speed plus (+) wind speed should not be exceed 40 mph.

B. Forward Bimini Canvas (234 & 264 Funships™)

A forward bimini top is optional on the 234 & 264 Funship™ models. The forward bimini provides shade for persons occupying the bow area. The forward bimini attaches to the standard rear bimini. See Figure O2.

To Install:

1. Attach the forward bimini main bow to the deck mounts.
2. Zip the forward bimini top to the aft bimini top.
3. Attach the forward brace rod to the deck mounts located on the deck.

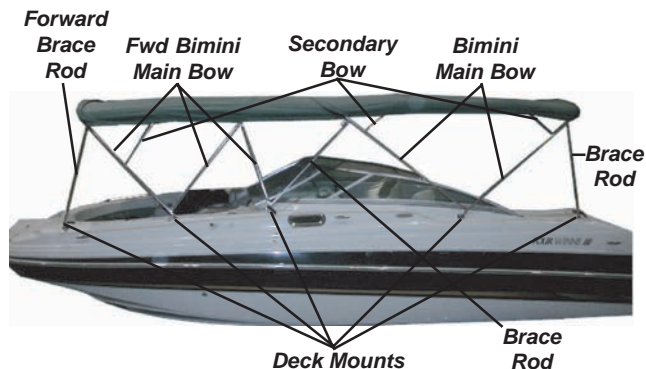

Figure O2: 234/264 FS Forward Bimini & Bimini Top

C. Camper Canvas

The camper canvas is an option available on the Funship™ models which encloses the cockpit area and allows for overhead space. The 214 Funship™ camper utilizes the existing aft bimini top, forward cover, forward connector, side curtains, and aft camper curtain. The 234/264 Funship™ campers also utilize the existing aft bimini top, side curtains, forward bow curtain and aft camper curtain. Covers roll up to expose the window screens. See Figure O3. Your Four Winns dealer will gladly assist you with your canvas selection as well as the installation.

To install:

1. Install bimini top(s) as previously instructed.
2. Zip the side curtains and forward connector (214 FS only) or forward bow curtain (234/264 FS only) to the bimini top(s). Snap the bottom portion of these curtains to either the top edge of the windshield or the deck respectively.
3. Unroll the aft camper curtain and attach forward edge of aft camper canvas to bimini zipper.
4. Depending on which the model you have either snap the bottom portion of the aft curtain to the transom and/or attach shock cords to deck.



CAUTION

Do not operate your 234/264 Funship™ with the camper canvas fully deployed. Visibility is greatly reduced when bimini/camper canvas is deployed. Remove and boot canvas prior to beginning your cruise. The camper canvas is designed for use while at rest only. Damage to canvas, mounting hardware, boat and/or injury may otherwise occur.



Figure O3: 234/264 Funship™ Camper Top

D. Forward Cover

The forward cover is optional on all Funship™ models. It is installed over the bow seating area and is snapped to the deck and to the cockpit cover at the walk-through. An adjustable pole is provided to adjust the canvas for tautness.

E. Cockpit Cover

The cockpit cover is used to cover the complete cockpit area and is intended as a short term storage cover. The cockpit cover is available on all Funship™ models.

To install:

1. Snap the forward edge of the cockpit cover to the walk-through on the windshield. Windshield snaps will slide to adjust to the canvas.
2. Secure the rear corners.
 - a. If the canvas has snaps along the aft edge, secure the corners.
 - b. If the canvas has shock cords along the aft edge, attach to knobs as shown in Figure O4.

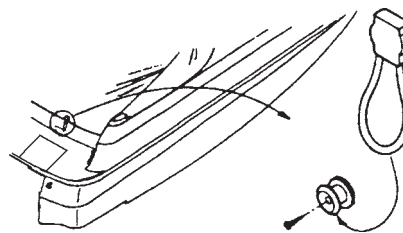

Figure O4: Shock Cords

3. Snap the cockpit cover sides and rear (if applicable) to the deck.

An adjustable pole is provided to adjust the canvas for tautness.

F. Mooring Cover

Mooring covers, available for all the Funship™ models, are intended for longer term storage and spread over the entire boat. If used in areas with snow accumulation, be sure to support the canvas adequately and inspect frequently for snow loads or damage will occur. Refer to O-3 Winter Storage for additional information. To install:

1. Spread mooring cover over entire boat.
2. Install adjustable poles in bow area and in the rear cockpit. Be sure the canvas is taut and no pockets exist.
3. Tie off at the transom.
4. Nylon loops are provided for attaching rope or bungee cords to the trailer or from side to side (under the boat).

O - 2 TRAILERING

High winds encountered during trailering your boat can severely damage most weather covers. If an extended trip at highway speeds is planned, the top and other weather covers should be in the down position or removed entirely. This will prevent damage and loss.

NOTICE

DO NOT tow your boat at highway speeds with weather covers in place. High winds encountered during trailering your boat can severely damage most weather covers. Damage to weather covers incurred as a result of trailering your boat is not covered under warranty.

O - 3 WINTER STORAGE

The boat must be properly protected during winter dry dock storage. A winter storage cover is advisable. Many marine dealers offer shrinkwrap enclosures for outdoor storage. See a Four Winns dealer for information on the availability of winter storage covers or other alternatives for storage.

When storing outdoors, make sure the supporting framework keeps the weight of the snow and rain from accumulating on the storage cover. Proper ventilation must also be provided or dry rot and mildew will occur. See Section R General Maintenance for additional winter storage information.

O - 4 CARE & MAINTENANCE



FOUR WINNS

RECOMMENDED CARE AND MAINTENANCE FOR YOUR FOLDING TOP AND ACCESSORIES

Your top and accessories should never be folded or stored wet. To clean top material, see manufacturers label for instructions. Occasionally your zippers and snap fasteners should be lubricated: White candle wax works well. The boat should never be trailered with the top erected. Side and aft curtains should be rolled with out creases in clear vinyl. Replacement parts are available through your dealer.

YOUR FOLDING TOP IS NOT WARRANTED AGAINST NEGLIGENCE OR MISUSE.

MODEL _____

DATE _____

WARNING: Do Not Operate Boat with Stern Curtain Closed. Cockpit must Be Open for Legal Fuel Compartment Ventilation.

Figure O5: Canvas Care & Maintenance Tag

Moisture, dirt, chemicals from industrial fallout, heat, ultraviolet rays and in some cases, salt water are factors which affect the longevity of acrylic covers.

1. Moisture can cause shrinkage and mildew. Allow the cover to dry thoroughly before disassembling tops. Keep it clean and well ventilated to prevent mildew. Spraying the weather cover with Lysol Disinfectant™ or similar product will help prevent mildew.
2. Dirt creates a starting point for mildew when moisture is present. Clean the top with a sponge or soft scrub brush and mild detergent when the cover is installed. Make sure cover is taut to help prevent shrinkage.
3. Chemicals cause decay if allowed to accumulate for long periods of time. Keep the cover clean to prevent decay.
4. Heat can cause cracks in vinyl components and stiffening of fabric when enclosed in plastic or polyethylene. DO NOT store the weather cover in polyethylene under direct sunlight or high temperature situations.
5. Ultraviolet degradation may occur under prolonged exposure to direct sunlight. Store the top in the boot when not in use.
6. Salt water can corrode brass, aluminum, or stainless steel fittings and fasteners. Keep fittings clean, lubricated, and waxed to prevent corrosion.

Clear vinyl curtains and windows demand extra care to prevent scratching. DO NOT use cloth or chamois skin. Dirt or grit in the cloth will scratch the vinyl window. Hose clean water onto vinyl to rinse off salt, dirt, or grime.

NOTICE

DO NOT use hot water. DO NOT dry in an automatic dryer. DO NOT dry clean or steam press.

Leakage after cleaning may be the result of insufficient rinsing. Re-rinse. If leakage continues, apply a coat of silicone air drying water repellent, such as Scotchguard™. See your Four Winns dealer for additional information on weather covers.

O - 5 CARBON MONOXIDE

When the boat is underway, a natural vacuum may exist with the right wind and sea conditions to draw the exhaust gases (which includes carbon monoxide) into the boat. When the side curtains are installed, this compounds the possibility of this occurring. See carbon monoxide canvas warning label below. Carbon monoxide may also be present when mooring or near sea walls. For more information, refer to Section B-2 Carbon Monoxide in this manual.

The carbon monoxide in exhaust fumes can be hazardous. It is important for you and your passengers to be aware of the potential safety hazard created by exhaust fumes. Familiarize yourself with the symptoms of individuals overcome by carbon monoxide, and most importantly, ways you can protect yourself and your guests.

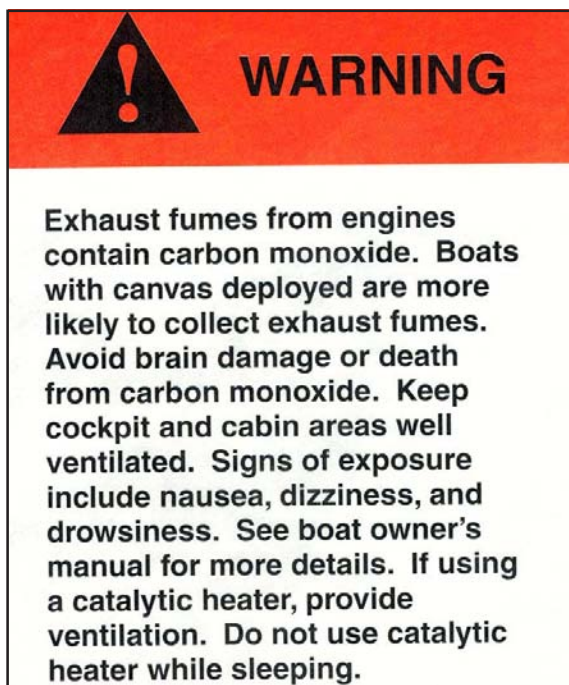

Carbon Monoxide Canvas Warning Label

FIBERGLASS AND HULL INFORMATION

P - 1 HULL DESIGN INFORMATION

Four Winns® boats are designed using the sound engineering and mathematical principles of hydrostatics, hydrodynamics, structure, and strength of materials. The materials utilized provide optimum strength at the lightest possible weight. The exact fiberglass laminate schedule and construction techniques of each part is determined in accordance with the strength and rigidity required.

P - 2 FIBERGLASS CONSTRUCTION

The fiberglass components of Four Winns® boats are of the finest quality materials, workmanship and construction techniques available. This ensures the structural integrity to provide years of boating enjoyment with minimal maintenance.

The construction of a Four Winns® hull begins with the application of gel coat to the mold. The gel coat is approximately 25 mils thick. A coat of resin and chopped fiberglass is then sprayed into the hull and carefully hand rolled until it is securely affixed to the gel coat.

A number of fiberglass layers and woven roving are applied to the above laminate. Each layer is hand laid and hand rolled. The keel and chine areas have fiberglass woven roving overlapped in these areas to provide additional strength. Some models utilize encapsulated end-grain balsa core or coremat laminates to achieve additional rigidity. Others utilize additional laminations of woven roving to maintain strength and rigidity.

The hull support stringers are located using special tools, and are fiberglassed into place. This ensures a strong, rigid hull, permanently formed into a solid assembly, free of distortions.

Fiberglass cockpit liners and seat base are constructed similar to the hull. Balsa core or coremat laminations are utilized when necessary.

In addition to a thorough visual inspection of each fiberglass component, samples are measured using special equipment, for fiberglass reinforcement to resin ratio, laminate configuration, weight and thickness. By these procedures Four Winns ensures proper composition.

P - 3 EQUIPMENT INSTALLATION

Many boats are used for specific purposes or under conditions which require the addition of special equipment to the hull or deck. Special care must be taken during the installation of any equipment to a fiberglass component. A polysulfide or butyl based sealant should be used to seal installations below the water line. Silicone "marine" seal or similar bedding compound should be used elsewhere.

NOTICE

DO NOT install any item onto or through the hull without adequately sealing the hull area penetrated by the installed item or related fasteners. Improper installations could cause leakage or allow water absorption and thus cause serious hull damage.

Always predrill fastening holes with a proper size bit. Predrilling will help prevent the fiberglass from splintering and thus causing unsightly damage. Also, countersink holes to prevent the gel coat from chipping.

Any equipment which will be subjected to cyclic loading or significant force should be through-bolted to a fiberglass component. A butt block or backing plate should be used to strengthen any area onto which an item will be mounted.

P - 4 FIBERGLASS CARE & MAINTENANCE

Fiberglass is affected by weathering processes and requires maintenance on a periodic basis to help maintain the beauty and shine. The effects upon the gel coat will be dependent upon boating conditions, storage, type of use, and the care given to the boat during the boating season.

Four Winns® utilizes fade-fighting gel coat in the exterior finish. It is specially formulated to resist fading and yellowing, and retain more of its original gloss than better grade gel coats. However, it is still important to maintain the gel coat to protect the finish.

A. General Maintenance

For fresh water use, the boat should be washed once or twice a month. When using in a salt water environment, considerable more care will be necessary. Be careful when selecting a cleaning agent. Hand dishwashing detergents are usually gentle and are recommended for cleaning gel coat. Cleaning products such as Ivory or Dawn hand dishwashing liquid can be safely used. Always read the label before using any product.

NOTICE

DO NOT use acetone, paint thinner, solvents, or strong alkaline based detergents, nor cleaners with a “gritty” and abrasive texture. Avoid products which contain sodium phosphate. Common examples of these types of household cleaning agents are: Tide™, Oxydol™, Janitor-in-a-Drum™, Fantastik™, Clorox™, etc. Always read the label before using an agent.

There are several products available which are specifically designed to clean fiberglass exterior finishes. Many companies like Johnson & Johnson®, Turtle Wax®, etc. manufacture cleaning fluids mild enough to clean without stripping the wax.

NOTICE

Treading on a soiled fiberglass surface can severely scratch and mar the finish. Keep the fiberglass as clean as possible.

When cleaning nonskid areas, DO NOT attempt to use a wire brush or sandpaper because this will remove the nonskid gel.

Apply wax once or twice a year to maintain gel coat lustre. Read the label before using any product. Make sure product is formulated for gel coat surfaces. Also, consult a Four Winns dealer for their recommendations.

NOTICE

Do not use carnuba based waxes. This type of wax yellows over time and makes the fiberglass appear yellow.

CAUTION

Waxing decks, cockpit floors or other areas on which one walks is not recommended. Waxing will produce a very slippery surface, especially when wet. Wax may also buildup in the nonskid surfaces. Be sure all persons wear deck shoes while aboard the boat. Footing will be improved and feet will be protected from accidental cuts and bruises.

A darkening or discoloration of the nonskid surfaces can sometimes occur as a result of wax buildup. Exposure to the sun and elements can turn the wax darker, or occasionally can cause it to become flaky or powdery. To remove, use fine rubbing compound and a low RPM buffer (1200 to 2000 RPM). Apply light pressure and keep the buffer moving at all times to prevent heat build up. Read the directions before using any equipment.

B. Weathering Effects on Gel Coat

Weathering occurs from direct sunlight, water, chemicals, and dust. Some of the terms below describe the changes that can occur to the gel coat surface.

Chalking is a result of the gel coat's top surface being broken down into an extremely fine powder. When this happens, the color whitens. The chalk is present on the surface only.

Fading is the uniform change in color. This happens when the actual pigments have changed color, especially from excessive chalking, or when the gel coat has either been stained or bleached by something.

Yellowing is gel coat which has a yellow cast and streaking usually deals with a stain or contact with another surface.

Gloss refers to the shine of the surface. This can change from sanding action, chalk, residues, or exposure.

Blistering refers to a condition in which the unprotected gel coat surface below the waterline has absorbed water and formed bubbles. See Section P-5 for additional information.

Follow the instructions below for boats that have weathered and chalked.

1. Wash.
2. Wax. If this does not work, then use a fine rubbing compound. If this does not work use 400 or 600 wet or dry sandpaper, followed by fine rubbing compound and wax.

When using wax or fine rubbing compounds, make sure to read the label and follow the directions. Some helpful tips are listed below.

1. Avoid working in direct sunlight. This dries out the wax or compound, and can stain the surface.
2. Use clean pads or cloths to apply a thin coating of wax or rubbing compound to a small area such as three feet by three feet. Remove any excess, and then rub the area with a buffing pad, or power buffer. Apply pressure only as necessary to restore the surface finish. Applying too much pressure or buffing in one place too long can permanently damage the surface.
3. After applying compound, always follow with waxing.

NOTICE

If using a power buffer, use a low RPM buffer with light pressure. Keep the pad wet and the buffer moving at all times to prevent heat build up.

NOTICE

When sanding, DO NOT use a power or belt sander to prevent gouges, uneven areas, or other damage. For best results, block sand the gel coat.

C. Stains

Stains can appear anywhere on the exterior of the boat and may be a result of contact with tar, plant sap, leaves, rust from metal fittings, and other materials. Surface stains may be removed with hand dishwashing soap, mild cleansers, or some household detergents. DO NOT use chlorine or ammonia products. These products can affect the color of gel coat. Commercial car washes use strong cleaners and should be avoided.

To remove stains, refer to the procedures below.

1. Wash area with hand dishwashing soap.

2. Begin with a small area such as three feet by three feet and apply a mild cleanser.
3. Rinse with clean water.
4. Follow with compound and waxing as outlined in procedure above.

If the stain is not removed by the hand dishwashing soap or mild cleanser, then the next procedure is to use either denatured or rubbing alcohol. If this does not work, consult your Four Winns dealer for professional assistance.

NOTICE

DO NOT use acetone, ketone, or other solvents to remove stains. These chemicals are flammable and may damage the gel coat.

P - 5 FIBERGLASS REPAIRS

Fiberglass is one of the most durable, strong, and forgiving construction materials afloat. It is resilient and normal repairs can be made without affecting the strength or structural integrity of the boat.

 **WARNING**

Striking docks, other boats, or submerged objects could create a very hazardous situation or severely damage the fiberglass. In the event an object is struck below or near the waterline, proceed directly and cautiously to the nearest service facility and remove the boat from the water. Closely inspect the hull for damage. If the outer fiberglass laminate was penetrated, repairs must be made prior to relaunch.

Occasionally, blisters, crazing, scratches, or damage to the fiberglass can occur. Repairs may be necessary to correct the problem.

A. Scratches

Scratches occur during normal use. Below is a step by step procedure to repair scratches.

1. Clean area with soap and water.
2. Apply a fine rubbing compound and buff.
3. Wax.

If this does not work, clean the area and sand lightly with 400 to 600 wet or dry sandpaper and follow with rubbing compound and wax.

B. Gouges & Cracks

Stress cracks and crazing are the appearance of hairline cracks in the gel coat surface. When present, these problems usually occur in the gel coat finish or the outer “skin coat” fiberglass laminate. The appearance of these cracks does not pose a threat to the structural integrity of the boat. In most cases, they are cosmetic and can be treated.

Cosmetic surface damage can be repaired as follows:

1. Sand the surrounding area with medium or fine grit sandpaper. Clean all marine growth, dirt, antifouling paint, etc. from the immediate area. **DO NOT** excessively scratch or gouge the surrounding area.
2. Use a hard, pointed tool to open the gel crack. Take care not to damage the surrounding gel coat.
3. Sand the crack or gouge so the edges are smooth and will allow proper “feathering” of the area.
4. Clean the area thoroughly. Make sure the area is dry before proceeding.

NOTICE

Be sure the structure and the ambient temperature are above 60 degrees F (15 degrees C) and the relative humidity below 70% immediately before, during, and after the repair.

5. If the nick or gouge is deep and penetrates through the gel coat, fill the area with fiberglass patching paste. Follow the directions on the can when mixing the paste with the catalyst.
6. After the gouge is filled and has dried, sand the patched area. Begin by using medium-fine grade sandpaper. Progressively use finer grade sandpaper until the surface is very smooth. If necessary, add filler and then sand the surface again.
7. Apply two or three light coats of matching fiberglass gel coat to the repaired area. Enough gel coat should be used so that the entire area is covered.

The gel coat must be catalyzed using up to 2% MEK Peroxide which can be purchased at a supplier handling fiberglass reinforced products. Contact your Four Winns dealer for assistance.

8. After ample drying time, sand the area using very fine wet/dry sandpaper. If the appearance of the area is still not satisfactory, repeat steps 2 through 8 as necessary.
9. If above the waterline, polish the area using a fiberglass rubbing compound and then wax. If the repaired area is below the waterline, the area should be primed and painted in accordance with the anti-fouling paint manufacturer’s instructions.

Gel coat, like paint, will change colors with time and exposure to sunlight (ultraviolet). For this reason, “matching” gel coat obtained from Four Winns may not match the gel color of a boat that has been exposed. However, this is the closest match commercially available. A fiberglass technician can tint the gel to be used in the repair to provide a closer color match.

More severe fiberglass damage, especially when structural, requires the expertise of an experienced fiberglass repair technician. See your Four Winns dealer for assistance.

NOTICE

Improper repair techniques can lead to further fiberglass component damage.

C. Osmotic Blistering

Osmotic blistering or “boat pox” is an unfortunate but not uncommon occurrence in fiberglass boats. Fiberglass is water retardant, not waterproof. When a boat is left in the water for a period of time, the fiberglass will absorb water. It is a natural process that can not be eliminated in production methods or material selection and usage. However, there are ways to control and possibly prevent blisters (see Section P-6). If you do encounter blisters, be assured that the blisters are merely cosmetic. They do not indicate a defect in the boat structure or lamination. Four Winns, along with most boat manufacturers, regard gel blisters as a standard maintenance item.

The repair procedure for gel coat blisters is similar to the procedures outlined in the previous section on cracks and gouges. There is an exception however, in that the hull must dry out for several days or possibly weeks before repairs can proceed.

To determine if the hull has dried sufficiently, tape one square foot of household plastic wrap securely to the hull bottom. Make sure all edges are sealed and let it stand for twenty-four hours. If condensation has accu-

mulated under the plastic, the hull is still “wet” and must be allowed to dry longer before repairing.

When the repair is completed, an application of an epoxy barrier coat should be considered. This will help prevent the possibility of reoccurrence of blisters. Your Four Winns dealer or local ship store will have information on barrier coat products.

P - 6 ANTIFOULING PAINT

Four Winns recommends antifouling or bottom paint for boats which will be kept in the water for extended periods of time. Antifouling paint reacts with water to retard the growth of algae, barnacles and other marine growth on the hull. In addition to marine growth, it offers protection against excessive water pollution.

Antifouling paint begins reaction upon contact with water. After a season’s use or sooner under certain conditions, the antifouling paint may appear to be dissolving. This is due to the paint’s chemical emission that in turn retards marine growth. When this occurs, refinishing is in order.

Four Winns recommends reapplication of the antifouling paint seasonally. The effectiveness of the paint will be drastically reduced if used longer. Though Four Winns has found the antifouling paints used to provide good marine growth protection in most water, other paints may be more effective in certain water conditions. See a Four Winns dealer for recommendations on antifouling paint use in your area.

NOTICE

During surface preparation, the hull should be sanded only enough to remove any foreign matter, and loose paint. DO NOT sand deeply into the gel coat, fiberglass cosmetic problems could later result. After sanding, the surface should be wiped with a rag treated with a cleaner recommended by the antifouling paint manufacturer. The surface must be clean and slightly rough to ensure paint adhesion.

Prior to application of the antifouling paint, the boat owner may consider coating the hull bottom with an epoxy coating. Four Winns recommends this procedure as a preventive and effective means of controlling osmotic blistering. Most major antifouling paint manufacturers also supply a line of epoxy undercoatings. Consult your Four Winns dealer for recommendations on epoxy undercoatings.

P - 7 HULL SUPPORT

Proper support of the hull while it is out of the water is imperative. Due to the design complexities, Four Winns does not recommend trailers or storage cradles be home-made. The boat is a valuable piece of equipment. DO NOT risk permanent damage to the hull structure in an attempt to save the cost of an adequate support. Improper support can lead to serious and permanent hull deformation.

 **CAUTION**

Failure to adequately support the hull may result in permanent hull structure damage and will invalidate the hull structure warranty.

NOTICE

When attempting to raise the hull, never allow one end of the boat to rise first, while letting the opposite rest momentarily on the outdrives or underwater gear. Serious damage to these components could result. DO NOT place lifting straps on underwater gear. Be sure the strap is against the hull surface only.

A trailer, or storage cradle designed for a larger or smaller boat will not provide proper support for the hull. This could lead to hull deformation and thus serious performance deficiencies.

Four Winns® trailers are available for all Funship™ models. Refer to Section S - Trailers for additional information.

WOODWORK AND COMPOSITES

Q - 1 HIGH-PRESSURE LAMINATE CARE

Table tops consist of a high pressure laminate, “formica” like material. The laminate has a “matte texture” finish and can be cleaned with hand dishwashing soap and water or other cleaning solutions such as Fantastik™. Always read the label before using any product.

NOTICE

DO NOT use abrasive cleaners or solvents on formica. DO NOT use Soft Scrub™ soap or similar cleaning products; they will scratch the surface and remove the shine.

NOTICE

DO NOT use table tops as a cutting board. The knife will leave gouges/marks in the surface of the table.

Q - 2 STAR BOARD

Star board is a high density polyethylene (plastic) and is very durable and fade resistant. Star board requires little maintenance, and is being used in place of wood in many areas of the boat. It is currently being used for ski rack facers, ski locker lids, and seat supports.

To clean star board, use a solvent-free, nonabrasive cleaner such as hand dishwashing soap or Fantastik™. Read the label before using any cleaning product.

NOTICE

Star board will stain when exposed to certain oils or chemicals. Always wipe up any spills immediately.

Q - 3 BURLWOOD MAHOGANY ENHANCEMENTS

Mahogany enhancements are standard on the Funship™ models. They consist of a finished synthetic burlwood mahogany. This mahogany is found in the instrument panels and ignition switch panels of the Funships.

To clean, a damp cloth will usually suffice.

Q - 4 CORIAN® MATERIAL

Corian® material is utilized in some of the entertainment and lid covers on some of the Funship™ models. The Corian® gives the Funships® a rich look and makes for an extremely strong yet lightweight top. It can be cleaned with hand dish washing soap and water, or other cleaning solutions such as Fantastik™. Always read the label before using any product.

Q - 5 LAMINATED FIBERGLASS

The Funship™ models come with a cockpit table standard which consist of a laminated fiberglass material. See Figure Q1. It can be cleaned with hand dish washing soap and water. Always read the label before using any product.

NOTICE

DO NOT use abrasive cleaners or solvents on cockpit table. DO NOT use Soft Scrub™ soap or similar cleaning products; they will scratch the surface and remove the shine.

NOTICE

DO NOT use cockpit table as a cutting board. The knife will leave gouges/marks in the surface of the table.



Figure Q1: Cockpit Table

GENERAL MAINTENANCE

R - 1 WINTERIZATION

A. Prior to Lifting for Winter Lay-up

1. Pump out the head (dockside discharge if applicable), and be sure the holding tank is empty. Flush the head holding tank with soap, water and a deodorizer (e.g., Lysol Liquid™). Add more water if necessary. Have the cleaning solution pumped out.
2. Have the fuel tank either full or completely empty. See the Engine Owner's manual for recommendations. Also, check with the dry dock operators for recommendations. If winter storing with a full fuel tank, gasoline winterizer such as Sta-bil® Fuel Conditioner will reduce varnishing, condensation, etc.

NOTICE

If the fuel has been treated with winterizer, run engines for ten minutes to make sure the treated fuel is present in all lines and parts of the engine.

3. Drain water from the fresh water system (if applicable).
4. Winterize the engine and drive systems as recommended in the Engine Owner's manual. Portions of this winterization procedure may require that the boat be lifted.
5. If the boat is to be lifted or taken off the trailer, see Section P-7 Hull Support in this manual for additional details.

B. After Lifting

1. Remove the drain plug.
2. Thoroughly wash the fiberglass exterior, especially the hull bottom. Remove as much marine growth as possible. Wax lightly.
3. Lower boat onto cradle properly or place boat on trailer. Be sure boat is adequately supported. The boat should be raised slightly under the forward supports or trailer tongue to improve drainage to the transom drain.

4. Be sure all the water is completely drained from the fresh water system. Disconnect all hoses, check valves, etc. and blow all the water from the system using very low air pressure. The use of nontoxic, fresh water system antifreeze is recommended as an alternative to disassembling the water system. Refer to Section J-5 System Maintenance in this manual for information on winterizing the water system.
5. Winterize the head as recommended by the head manufacturer. If the boat is equipped with a holding tank, mix some antifreeze solution and pour it into the head. Transfer some of the antifreeze to the holding tank by flushing the head. Also, refer to Section J-5 System Maintenance for additional information.
6. Ensure that all water is removed from the bilge pump and bilge pump lines. Dry the hull bilge, and self-bailing cockpit drain troughs. Water freezing in these areas could cause damage. See Section K-2 Hull Drainage Systems.
7. Remove the battery(s) and store in a cool place. Clean the batteries using clear, clean water. Be sure the battery has sufficient water and clean terminals. Keep the battery(s) charged throughout the storage period. **DO NOT** store the battery(s) on a concrete floor or other damp or conductive surface.
8. Remove the butane canister from the stove (if applicable) and store in a cool, dry place away from heat or spark.
9. Clean the boat interior thoroughly. Vacuum carpets.
10. Wash exterior fiberglass components, wax lightly.
11. Clean exterior upholstery with mild soap and water. Rinse and dry thoroughly.
12. Remove all oxidation from exterior hardware and apply a light film of moisture - displacing lubricant.

C. Prior to Winter Storage

1. Remove as many cushions as possible. Remove storage lids or hatches. Open as many locker doors, as possible. Leave these areas open to improve ventilation.
2. Spray the weather covers and the boat upholstery with Lysol Spray Disinfectant™. Enclosed areas such as storage locker areas should also be sprayed with Lysol Disinfectant™.
3. Place small dishes of rodent poison such as D-Con™ in a number of areas around the boat. Be sure dishes are placed near the head and the engines, as rodents will destroy upholstery, water intake and discharge hoses.
4. If the boat will be in outside storage, properly support a storage cover and secure it over the boat. DO NOT secure the cover tightly to the boat. This does not allow adequate ventilation and can lead to dry rot. DO NOT store the boat in a damp storage enclosure. Excessive dampness can cause electrical problems, corrosion, and dry rot.
5. DO NOT use the bimini top or camper top as a winter storage cover. The life of these covers may be significantly shortened if exposed to harsh weather elements for long periods.

 **WARNING**

Placing an electric or fuel burning heating unit in the bilge of the boat during cold weather could cause fire or explosion and is not recommended.

NOTICE

Boats stored outside in areas with heavy snow accumulation are more susceptible to damage, and should be inspected regularly during the winter months

6. **Engine should be winterized according to the engine manufacturers manual.**

R - 2 ENGINE FLUSH OUT

The optional engine flush out should be used to clean the engine of unwanted salt, mud, sludge, etc. which may have accumulated in the engine cooling system. Before winterizing the engine, flush out the system for at least five minutes.

 **CAUTION**

Make sure that no section of flush hoses are in contact with moving or hot engine parts or abrasive surfaces such as screw threads, sharp edges, etc., which could damage the hoses. Damage to the hoses could cause leaks and possible flooding of the engine compartment. Periodically check hoses for abrasions.

NOTICE

The flush out kit should only be used with the boat in the water and the engine OFF.

To flush out the engine, follow the instructions below.

1. **Do not run engine during flushing procedure.**
2. Remove cap from coupling and attach swivel connector.
3. Attach water supply hose to swivel connector.
4. Turn water on and allow water to flush the engine and exhaust manifold for five to ten minutes.
5. Turn water off. Disconnect hose; replace and tighten cap securely.

 **CAUTION**

Reinstall cap onto coupler after flushing. Flooding of the engine compartment will occur if the cap is not installed and tightened.

R - 3 GENERAL MAINTENANCE SCHEDULE

SERVICE	AT LAUNCH AND FIRST OPERATION*	25 HOUR CHECK EACH SEASON*	BI-SEASONALLY OR EVERY 6 MONTHS OR EVERY 100 HOURS*	SEASONALLY OR EVERY 12 MONTHS OR EVERY 200 HOURS*
Engine and Instrumentation	Refer to Section E			
Engine Maintenance	As Recommended by the Manufacturer			
Inspect Exhaust System Hoses and Connections				
Check Propellers				
Check All Thru-Hull Fittings				
Test Emergency Shut-Off Switch				
Gauge Cleaning				
Controls Systems	Refer to Section F			
Throttle and Shift Adjustment				
Neutral Safety Switch Test				
Cable and Control Lubrication				
Steering Systems	Refer to Section G			
Linkage and Connection Inspection				
Stern Drive Torque Tab Adjustment				
Power Steering Service	As Recommended by the Manufacturer			
Steering Adjustments				
Steering System Lubrication				
Electrical Systems	Refer to Section H			
Inspect Battery Connections				
Check Battery Water				
Battery Cable Inspection				
12 Volt Electrical Equipment Operation				
12 Volt Wiring and Connection Inspection				
Fuel System	Refer to Section I			
Inspect for Leaks				
Fuel Sender Inspection				
Fuel Filter Inspection				
Fuel Tank Inspection				

* Or as Required

 — Shaded areas indicate the time frame when service/inspection should be conducted.

SERVICE	AT LAUNCH AND FIRST OPERATION*	25 HOUR CHECK EACH SEASON*	BI-SEASONALLY OR EVERY 6 MONTHS OR EVERY 100 HOURS*	SEASONALLY OR EVERY 12 MONTHS OR EVERY 200 HOURS*
Water Systems	Refer to Section J			
Inspect All Water Systems				
Fresh Water Tank Inspection				
Drain & Flush Fresh Water System				
Ventilation and Drainage	Refer to Section K			
Blower Operation				
Blower Vent System Cleaning				
Bilge Pump Operation and Cleaning				
Check Transom Drain Plug				
Deck Hatch & Porthole Operation				
Interior Equipment	Refer to Section L			
Head Maintenance	As Recommended by the Manufacturer			
Thru-Hull Fitting Inspection				
Clean Cooler				
Stereo Head Cleaning and Demagnetizing				
Exterior Equipment	Refer to Section M			
Check PFD's for Serviceability and Correct Number	As Required			
Check Charge of Fire Extinguishers	As Required			
Check Compass for Magnetic Deviation				
Check Trim Tab Fluid Level				
Check Trim Tab System for leakage				
Upholstery	Refer to Section N			
Clean Upholstery				
Clean Carpet				
Spray Upholstery with Lysol				
Check Seat Hinges and Mounting Hardware				

* Or as Required

— Shaded areas indicate the time frame when service/inspection should be conducted.

SERVICE	AT LAUNCH AND FIRST OPERATION*	25 HOUR CHECK EACH SEASON*	BI-SEASONALLY OR EVERY 6 MONTHS OR EVERY 100 HOURS*	SEASONALLY OR EVERY 12 MONTHS OR EVERY 200 HOURS*
Weather Covers	Refer to Section O			
Wash Weather Covers				
Spray Weather Covers with Lysol				
Fiberglass Components and Hull	Refer to Section P			
Check All Fastenings (securing rails, seats, etc.)				
Clean Fiberglass Thoroughly				
Wax Hull Sides and All Non-Tread Areas				
Inspect Fiberglass Areas for Damage				
Perform Minor Touch-Up Repairs				
Sand Hull and Re-Apply Anti-Fouling Paint				
Woodwork & Composite Maintenance	Refer to Section Q			
Clean Star Board	As Needed			
Clean Cockpit Tables	As Needed			
Trailers	Refer to Section S			
Wax Trailer				
Lubricate Trailer Jack				
Lubricate Trailer Coupler				
Lubricate Trailer Winch				
Brake Operation	Before Every Use			
Brake Inspection				
Inspect Hubs/Disc Brakes				
Inspect Bearings & Seals				
Lubricate Bearings				
Springs, Hangers & Suspension Parts				
Wheel Lug Nut				
Wheels				
Tire Pressure & Condition	Before Every Use			

* Or as Required

— Shaded areas indicate the time frame when service/inspection should be conducted.

TRAILER INFORMATION

S - 1 GENERAL TRAILER INFORMATION

The trailer must properly “match” the boat’s weight and hull design. Four Winns® trailers are designed specifically for each boat model. Four Winns® trailers meet or exceed the National Marine Manufacturers Association’s trailer requirements.

Four Winns manufactures bunk type trailers. The bunks are located specifically for Four Winns® boats and adequately support all parts of the boat. It is a “drive-on” type trailer which means winching the boat from the water is not necessary.

NOTICE

When winching the boat onto the trailer, **be sure the bunks are wet to prevent damage to the boat or trailer.** DO NOT attempt to winch the boat forward when out of the water. Damage to the winch stand/assembly or tongue could occur.

Four Winns offers both painted and galvanized trailers. The painted trailer is intended to be used in fresh water and the galvanized trailer in salt/brackish water.

NOTICE

Four Winns does not recommend the usage of painted trailers for salt/brackish water conditions, as trailer life may be substantially reduced.

A. Regulations

Federal law requires that the trailer and tire registration information be compiled and recorded. The Four Winns® boat registration card includes trailer registration information. A trailer tire warranty card included in the owner’s packet, is to be filled out and returned to the tire manufacturer.

NOTICE

The warranty of the tire is administered by the manufacturer of the tire. The manufacturer of the tires on your trailer is Carlisle Tire. Please call 1-800-260-7959 regarding any warranty concerns relating to your tires.

Laws covering such items as trailer brakes, lights, safety chains, etc., will vary from state to state. Please contact the motor vehicle department in your state for additional information.

B. Load Carrying Capacity

The certification label shows the maximum load-carrying capacity and is located on the port forward side of the trailer. The Gross Vehicle Weight Rating (GVWR) is the load-carrying capacity plus the weight of the trailer itself. DO NOT exceed the GVWR rating for the trailer.

NOTICE

When using or choosing a tow vehicle with the correct GVWR, you must consider not only the weight of the boat and trailer but also the weight of the fuel, water, equipment, etc. Refer to Table 1 below:

EQUIPMENT	WEIGHT (AVERAGE)
Battery	50 Lbs.
Fuel	6.5 Lbs./Gal.
Water	8 Lbs./Gal.
Accessories	150 Lbs. (Approximate)

Table 1: Average Equipment Weight

If selecting a trailer from another manufacturer, check the load-carrying capacity. A trailer with a load-carrying capacity that is too low will be unsafe on the highway and could cause sudden failure of critical trailer components or abnormal tire wear. A trailer with too high of a load-carrying capacity that is sprung for heavy loads can damage a lighter boat.

NOTICE

DO NOT overload your trailer by placing camping gear or other heavy equipment in the boat. DO NOT exceed the GVWR rating. Damage to the hitch, coupler, or trailer may occur.

Improper weight distribution can place excessive strain on the towing vehicle and trailer. It can also cause the trailer to “fishtail” (sway side to side). Be sure gear and other items are distributed evenly in the boat.

C. Hitches

The load-carrying capacity of trailer hitches will vary between manufacturers and must equal or exceed the GVWR. Four Winns® trailers use surge disc brake systems and require a fixed hitch. Refer to Section S-2E Surge Disc Brakes for more information.

Before hitching the trailer to the vehicle, make sure the proper size hitch ball is installed to match the coupler. Please refer to the coupler or actuator on the trailer for ball size. Four Winns® 214 Funship™ IO trailers require a 2" diameter hitch ball and a 2 5/16" diameter hitch ball is required for the 234/264 Funship™ trailers. Refer to Section S-3 Operation for additional information on hitches. Also, consult your Four Winns dealer for his recommendation before purchasing a trailer hitch for your towing vehicle.

WARNING

To help guard against a sudden failure while in use, **do not use a worn hitch ball.** Replace all worn or damaged parts.

S - 2 TRAILER COMPONENTS

A. Bunk Supports

All bunk boards are made of pressure treated wood. This wood is rot resistant. All boards are covered with a high quality exterior grade carpet to protect the boat from damage during normal use.

Bunk supports run parallel to the keel and support the hull, extending beyond the transom. See Figure S1.

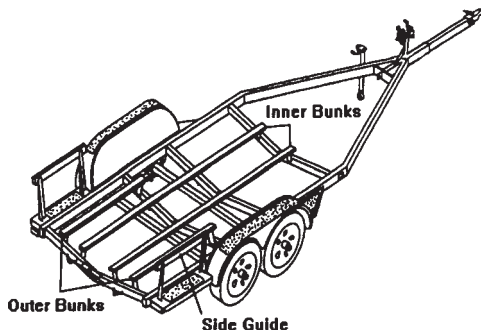

Figure S1: Trailer Bunks

Outer bunk supports provide stability for the boat. The inside bunks are the main weight bearing members. Side guide-on supports help to keep the boat straight while driving the boat onto the trailer. Keeping the tie-downs tightly fastened will prevent the boat from bouncing against the bunk supports.

NOTICE

Improper trailer setup can cause hull damage.

B. Tongue

Four Winns® trailers are designed with tongue weights between 5% and 10% of the total weight of the boat, fuel, gear and trailer. If the downward weight on the coupling ball does not fall within this range, coupler failure and towing instability may occur. If using another manufacturer’s trailer, have the dealer check the tongue weight before trailering.

NOTICE

DO NOT use a bent or damaged tongue or coupler. Replacement parts may be ordered through a Four Winns dealer.

The trailer tongue is hinged on our painted trailers and removable on our galvanized trailers. This allows for easier storage. The tongue is attached with two clevis pins with locking hair pins to the trailer frame. Refer to Figure S2.

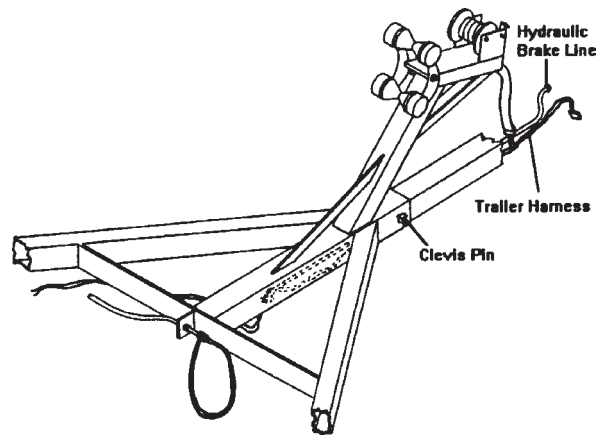

Figure S2: Trailer Tongue Assembly

To pivot the tongue on painted trailers for storage:

1. Make sure the trailer jack is supporting the trailer load properly. Refer to Section S-2C on Swivel Jacks for additional information.
2. Unplug the wire harness at the trailer cross member.
3. Disconnect the brake line coupler.
4. Remove the locking hair pins and clevis pins. Please note, the locking hair pins must be rotated away from clevis pin and then removed.

NOTICE

The tongue will exert some pressure on the clevis pins. It may be necessary to lift, push or wiggle the tongue to remove the clevis pins.

5. Slide trailer tongue out of receiver until the hinge is exposed. Pivot the tongue towards the trailer as far as it will go.

To reinstall, follow this procedure in reverse order.

1. Pivot the tongue so that it extends straight and is in alignment with the receiver.

NOTICE

When extending tongue ensure that the brake line and wire harness are not pinched. Failure to check could result in damage.

2. Slide the trailer tongue into the receiver until the clevis pin holes are aligned.
3. Insert clevis pins with washers and locking hair pins.

NOTICE

The tongue will exert some pressure on the clevis pins. It may be necessary to lift, push or wiggle the tongue to insert the clevis pins.

4. Reconnect the brake line coupler.
5. If towing the trailer, remember to plug the 5-wire tongue harness to the trunk connector wire harness of your tow vehicle.

 **CAUTION**

Make sure the trailer tongue is secure before hitching to the towing vehicle.

To remove the tongue on galvanized trailers:

1. Make sure the trailer jack is supporting the trailer load properly. Refer to Section S-2C on Swivel Jacks for additional information.
2. Unplug the wire harness at the trailer cross member.
3. Disconnect the brake line coupler.
4. Remove the ring cotters and clevis pins.

NOTICE

The tongue will exert some pressure on the clevis pins. It may be necessary to lift, push or wiggle the tongue to remove the clevis pin.

5. Slide trailer tongue out of receiver and store in a proper place. If the trailer has brakes, store the tongue upright to prevent brake fluid from leaking.

To reinstall, follow this procedure in reverse order.

 **CAUTION**

Make sure the trailer tongue is secure before hitching to the towing vehicle.

C. Swivel Jack

The jack is designed to lift, lower and support the tongues of the trailers when not connected to the towing vehicle. Before unhitching the trailer, use the following guidelines when setting up the jack.

1. Pull on the lock pin. See Figure S3.
2. Swivel jack to the vertical position.

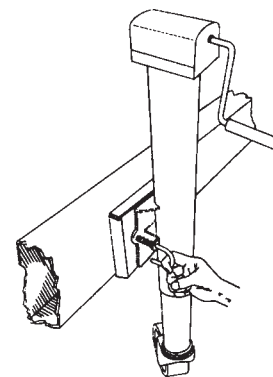

Figure S3: Swivel Jack

3. Release the lock pin and make sure the pin fully engages the attached tongue bracket.



CAUTION

Be sure dirt, sand, ice, etc., does not obstruct the proper seating of the lock pin.

4. When raising or lowering the jack, prevent the caster from rotating while cranking. Make sure the jack is planted on a firm and level surface before unhitching the trailer.



WARNING

To prevent personal injury or damage to the boat and trailer, observe the following:

- NEVER pull on the lock pin when any trailer weight is on the trailer jack.
- DO NOT move the trailer when resting on the swivel jack. Use towing vehicle to move the boat and trailer.
- Keep body and feet clear of trailer tongue when raising or lowering jack.

Always remember to swivel jack to the horizontal position before towing the trailer. Damage to the caster and jack may result.

The swivel jack provided on the Four Winns® trailer can be removed from the trailer to allow for maintenance or repairs. Follow the manufacturer's recommendations provided in the owner's packet.

D. Coupling Assembly

To unlock the coupler, pull the locking trigger upward with your index finger and lift the locking lever. To lock, push the locking lever down. See Figure S4.

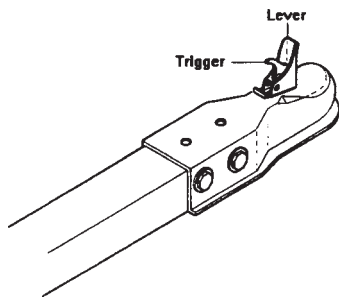

Figure S4: Coupling Assembly

and Coupling Assembly.

E. Surge Disc Brakes

Surge disc brakes are available on model trailers manufactured by Four Winns. Surge disc brakes operate automatically when the tow vehicle's brakes are applied. When the tow vehicle slows down or stops, the forward momentum or "surge" of the trailer against the hitch ball applies pressure to a master cylinder in the trailer coupler. The master cylinder supplies hydraulic pressure through the hydraulic system which activates the trailer's disc brakes. See Figures S5 and S6. Please refer to the manufacturer's literature included in your owner's packet for further details regarding operation and maintenance.

The benefits of disc brakes in comparison to drum brakes:

- Fewer moving parts.
- Longer life due to fewer moving parts.
- Friction pads are easily accessible.
- Easy access to caliper for cleaning and maintenance.
- Calipers are self-adjusting allowing smoother braking operation.
- Braking performance less likely to be affected by dirt, water, or rust contamination.
- Fade resistant.

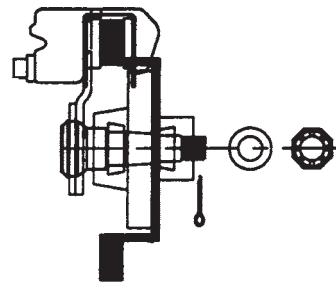
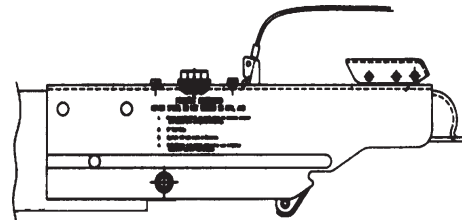

Figure S5: Brake Actuator & Coupling Assembly and Disc Brake

For boat models with the Surge Brake Actuator and Coupling Assembly shown in Figure S6, lift the release handle to unlock the coupler. Push down on the release handle/locking lever to lock the trailer to the ball hitch. The locking pin, provided with the trailer, or a padlock **must be inserted** in the locking lever hole. This ensures the coupler's locking lever remains in the locked position during towing of the trailer. Refer to Section S-3 Operation for additional information on couplers and hitching to the tow vehicle.

NOTICE

Anti-sway devices as used on recreational vehicles (RV's) are not applicable to surge brake systems and should not be used on Four Winns® trailers.

DO NOT use a trailer hitch with moving parts. The brakes could activate when traveling downhill. Always use a fixed hitch.

If the brakes are wet from loading, travel at a slow speed and apply the brakes on your towing vehicle several times to "dry" out the trailer brakes.

Release handle must be in open position to remove from or place on ball.

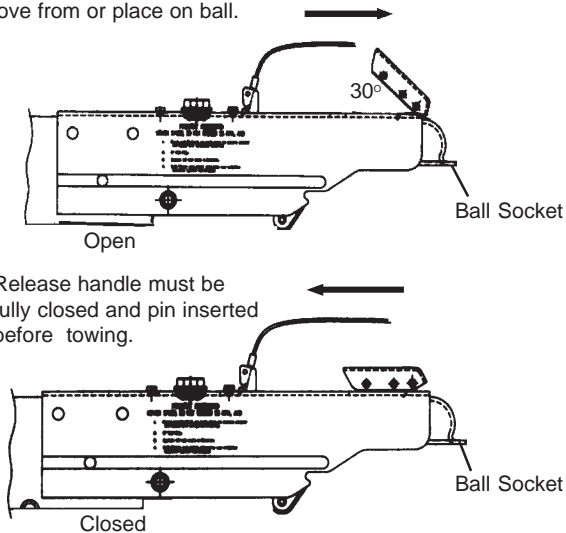

Figure S6: Surge Brake Actuator & Coupling Assembly

The brake actuator and coupling assembly comes with a 5-wire plug for connecting to the tow vehicle's trailering harness. Figure S7 depicts the 5-wire plug, the color of the individual wires, and the designated circuit for each wire.



Figure S7: 5-Wire Plug Harness

For maintenance and other information, refer to the manufacturer's literature included with in the owner's packet.

F. Winch

Winch operating instructions are listed below.

To release the winch, place the ratchet in the REVERSE or NEUTRAL position. The winch handle may spin when pulling on the winch line.

CAUTION

To prevent personal injury, observe the following:

A spinning winch handle can cause injury. Be sure the area is clear.

DO NOT release the handle when the ratchet is disengaged. Be sure the ratchet is engaged or no load is on the winch before releasing the handle.

CAUTION

To prevent personal injury, ALWAYS inspect the winch line and hook before each use. NEVER use line that is worn or frayed. NEVER let anyone stand in or behind a boat while pulling with the winch.

To rewind the winch, ALWAYS engage the ratchet first. Turn the handle in the appropriate direction to rewind the line.

CAUTION

A clicking sound will be heard when the winch is properly engaged. If a clicking sound is not heard, DO NOT release the handle. Handle may spin backwards. Lower the load into a safe position before releasing the handle.

Refer to the manufacturer's literature, included in the owner's packet, for more information on winch operation.

G. Tires & Wheels

Trailer wheel rims are available in three types of finishes: white, aluminum and galvanized. The white, powder coat finish is standard. Aluminum rims (Mags) are optional on painted trailers. Galvanized trailers are equipped with matching galvanized rims. Spare tire covers are available as an option and will match the trailer.

The tires installed on Four Winns® trailers meet the trailer load requirements for each model. Before trailering, make sure the tires are inflated according to the manufacturer's recommendation. Tire pressure information is noted on the tire and in the manufacturer's literature included in the owner's packet.

NOTICE
Carlisle Tire Registry

Ensure to fill out your name and address on the tire registration form provided in your owner's packet. Mail it to the tire manufacturer for the purposes of compliance with Federal defect notification regulations.

Mag wheels include a locking-type nut to help deter theft. This nut requires a special key or socket to remove. The socket will be included with your trailer when mag wheels are ordered. Refer to Figure S8.

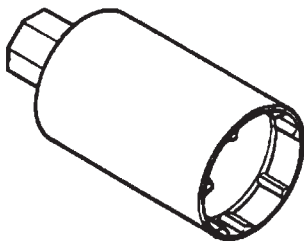

Figure S8: Mag Wheel & Mag Wheel Key (Socket)

NOTICE

DO NOT use an air wrench or other power equipment to install lug nuts on aluminum (Mag) wheels. Damage to the wheel may result. Lug nuts should be torqued to 85 foot pounds.

Examine the tires frequently for snags, bulges, excessive tread wear, separations or cuts.

Refer to the manufacturer's literature included in the owner's packet for more information.

NOTICE

The warranty of the tire is administered by the manufacturer of the tire. The manufacturer of the tires on your trailer is Carlisle Tire. Please call 1-800-260-7959 regarding any warranty concerns relating to your tires.

H. Spare Tire Carrier

Spare tires are optional on all Four Winns® trailers. A spare tire carrier is bolted to the trailer frame and is available in painted or galvanized finish. A spare tire carrier and wheel can be ordered from your Four Winns dealer. Refer to Figure S9.

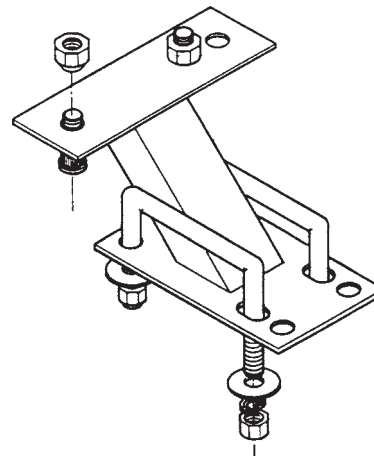

Figure S9: Spare Tire Carrier

I. Lights

Four Winns® trailers are equipped with taillights, brake lights, turning signals, and clearance lights. All lights are sealed to prevent moisture from entering. However, the taillight bulb assembly may be replaced. The bulb is assembled in a sealed housing and can be replaced. Contact your Four Winns dealer for assistance.

NOTICE

Use a heavy duty turning signal flasher on towing vehicles. Check with your local auto parts store or ask your Four Winns dealer for assistance.

Consult your dealer for state trailer regulations concerning lighting and other optional equipment.

J. Tie-downs

The boat should be secured to the trailer by tie-downs to prevent damage to the hull. The boat may shift or bounce against the bunks or hull supports if not secured. It may also slide or fall off the trailer while being towed.

There are two types of tie-downs being used:

1. **Bow Tie-downs:** A bow stop to hold the front of your boat in place is located on the winch stand. It should be positioned so that the winch line pulls straight and is parallel to the trailer frame. A separate tie-down should then be attached to hold the boat. See Figure S10.

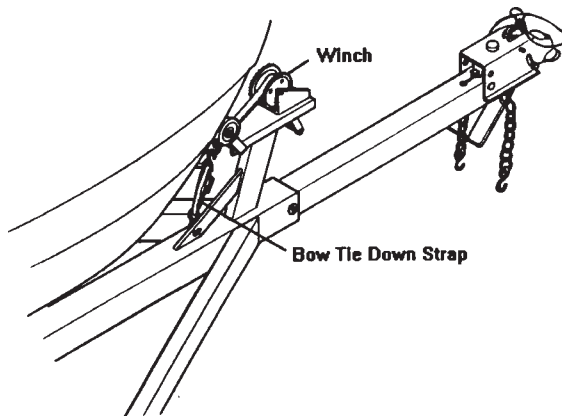
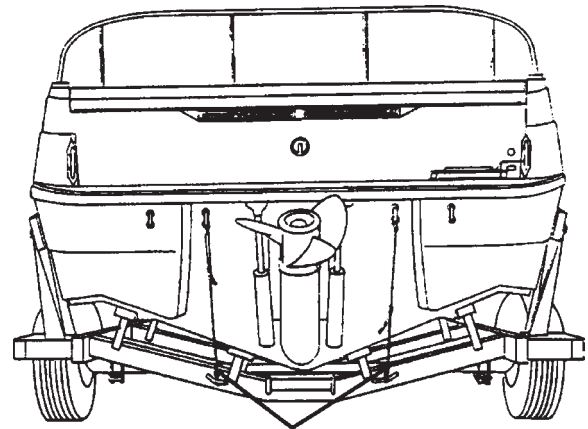

Figure S10: Bow Tie Down Strap

NOTICE

DO NOT rely on the winch cable (or line) alone to hold the bow of the boat against the bow stop. A bow tie-down is provided with the Four Winns® trailer.

2. **Rear Tie-downs:** It is very important that the transom is resting securely on the bunk supports at the rear of the trailer. Rear tie-downs are provided to secure the boat to the trailer. Tighten the tie-downs to prevent the boat from moving. See Figure S11.



Rear Tie Down Straps

Figure S11: Rear Tie Down Straps

The tie-down is a mechanical ratchet device. To allow line out, follow the procedures below:

1. Place two fingers on spring-loaded release, and pull release away from spindle/gear.
2. Open tie-down to a flat, 180° position.

NOTICE

Spring-loaded release should click into a notch on the painted handle. Both spring releases should clear the inner gear.

3. Pull line out. The inner spindle/gear should move freely.

To ratchet line or tighten down the strap on the boat:

1. Place two fingers on spring-loaded release, and pull release away from spindle/gear.

- Bring both handles together. Both handles should ride on the inner gear.
- Open (to approximately 110°) and close handles to ratchet. Leave in closed position to maintain pressure on line.

S - 3 OPERATION

A. Hitching Trailer

Before towing, the trailer must be properly hitched to the tow vehicle.

WARNING

To ensure proper engagement of the actuator's coupler to the tow ball, **DO NOT** use a multi-piece ball, an incorrectly sized ball, or a worn/damaged ball. **Four Winns® 214 Funship™ IO trailers require a two inch (2") diameter tow ball. A two & five-sixteenths (2 5/16") diameter tow ball is required for the 234/264 Funship™ trailers.**

- Position actuator ball socket above ball hitch.
- Lift up on release handle fully (approximately 30° for a trailer with brake actuator and coupler assembly) to allow the ball latch to rotate open. The handle will remain up to indicate that it is not yet attached to the ball. See Figure S6.
- Lower trailer tongue until ball is seated or rests in ball socket.
- Close release handle. If it is a trailer with brake actuator and coupler assembly the handle will snap to its closed position when properly seated.

The release handle will close freely with finger pressure when ball is properly seated in socket. **If the handle does not close freely or does not snap to its closed position properly, do not tow trailer. DO NOT** force handle into closed position, otherwise damage could result. Inspect actuator for bent parts or cause of improper operation.

NOTICE

Keep the coupler clean and lubricated to prevent damage to the coupler.

- Make sure the actuator is secure. If unsure, extend the trailer tongue jack to the ground and lift (with the jack) the car and trailer combination approximately 2" to 4". If the ball does not disengage and remains secured, the actuator is latched properly.

NOTICE

To prevent back injury, **DO NOT PHYSICALLY LIFT** the trailer tongue when loaded.

- The locking pin, provided with the trailer, or a padlock **must be inserted** in the locking lever hole. This ensures the coupler's locking lever remains in the locked position during towing of the trailer. Use of a padlock will help to deter theft.
- Connect break-away cable S-hook securely to one of the tow vehicle hitch's safety chain connection points. The cable should hang clear of trailer tongue and be long enough to permit short radius turns without pulling break-away cable forward. **DO NOT** loop the break-away cable around a bracket and loop it back onto itself.
- Make sure the break-away lever is fully rotated to the rear with the break-away catch pin securely located under the break-away spring. The break-away catch pin will be in the lever's uppermost notch. See Figure S12.

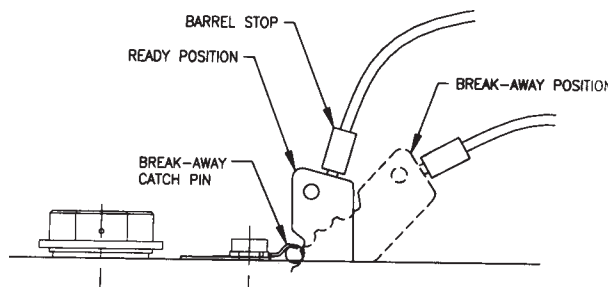

Figure S12: Break-away Cable

CAUTION

The Break-away system is not designed to operate if the trailer does not separate completely from the tow vehicle, or if the trailer tongue "submarines" and goes beneath the tow vehicle. **DO NOT** use break-away cable as a parking brake.

- Safety chains are provided and must be used. Cross the safety chains under the coupling and attach to the towing vehicle's frame or bumper. See Figure S13. Always allow slack for turns. Four Winns provides securement clips for the safety chain hooks and recommends you use them. Regulations vary from state to state. Please check the local laws in your state.

WARNING

The trailer safety chains' length **MUST** be set short enough so the actuator's break-away cable is **NOT** pulled if the coupler separates from the tow vehicle's hitch but remains connected by the safety chains. The break-away system should only be activated after **BOTH** the trailer's coupler and safety chains have failed and allowed the trailer to completely separate from the tow vehicle. Provide just enough slack in the trailer safety chains to allow short radius turns. The chains should not drag on the ground. **Safety chains must be used.**

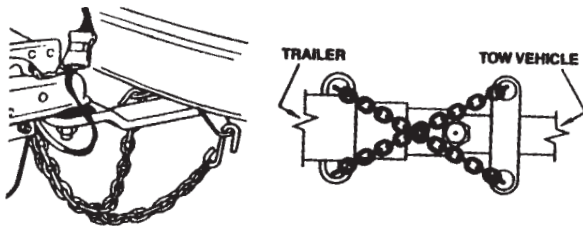

Figure S13: Crossing the Safety Chains

WARNING

To reduce the risk of Break-away accidents, be sure coupler is seated and safety chains criss-crossed before trailering.

NOTICE

Rubber safety chain straps are included on the "S" hooks to prevent chains from bouncing off of the tow vehicle and **must be used.**

- Retract jack fully and place in trailering or horizontal position.

WARNING

Be sure the tow vehicle and trailer are level and have a positive tongue load. This will allow the brake actuators to function properly on trailer models having such braking systems.

Be sure to read the manufacturer's literature, included in the owner's packet, before towing your Four Winns® boat and trailer.

B. Backing Up With Surge Disc Brakes

Follow the steps listed above for hitching the trailer before backing up.

- Before backing up a slope or through soft ground, pull the trailer forward slightly to assure the actuator socket is in the fully forward position.
- Back the trailer up.

CAUTION

Avoid sharp turns. This could bend, create extreme stress or fracture either the actuator or trailer tongue.

NOTICE

Be sure to check for obstacles or persons behind the trailer before backing up. Also, adjust your mirrors for clear view of the area behind the trailer.

- If the trailer is to be uncoupled from the tow vehicle after backing, block all trailer wheels and pull forward slightly to take strain off the actuator.

Uncouple the actuator by lifting the release handle and raise the trailer tongue with the jack.

For most trailering conditions, the brake actuator will allow you to back up normally. However, if the coupler is not wired or if there is a failure the trailer can still be backed up by using the manual brake lockout.

To use your lockout, check that no force is being applied to the actuator. This is achieved by positioning the towing vehicle and the trailer on a flat service, or with the trailer downhill from the tow vehicle. Set the vehicle's parking brake.

Rotate the lockout assembly forward and up. See Figure S14. Then push it rearward, so the pin ends will rest in the notches in the sides of the outer case. The actuator is now "locked out" and will not apply any noticeable pressure to the trailer brakes as you back up. If you can not rotate the assembly forward enough to reach the notch, make sure the actuator's coupler case assembly is pulled fully forward out of the outer case.

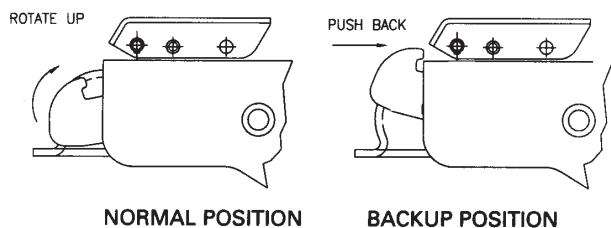

Figure S14: Brake Lockout Mechanism

NOTICE
Trailer components may be different between models and may change during the model year. Be sure to read all manufacturer's literature supplied with your Four Winns® trailer.

S - 4 TRAILERING

A. Checklist

Before trailering, the trailer should be inspected for the following:

1. Check tires for proper inflation. Under-inflated tires heat up rapidly and may blowout or cause uncontrolled swaying. Also, make sure lug nuts are tight.
2. Be sure the coupler is secured to the trailer hitch and safety chains are attached.
3. Be sure trailer taillights and turning signals are operational.
4. Check the brakes for proper operation prior to departure.
5. Check lug nuts for proper tightness.
6. Check tie-downs and make sure boat is secured to the trailer.
7. Check the springs and under carriage for loose parts.
8. Before towing, close and secure all hatches, doors, and windows. Securely store all equipment and canvas. Installed tops, side curtains, and aft curtains can be damaged while towing.
9. Carry a spare tire for both the trailer and towing vehicle. On extended trips, carry spare wheel bearings, seals, and races. Be sure and carry the proper tools to complete the repairs.
10. Before trailering, inspect the bearings for wear and adequate lubrication. When traveling, check the wheel hubs during stops at gas stations, restaurants or other places. If the hub feels abnormally hot, the bearing should be inspected before continuing the trip.

 **WARNING**

To avoid bearing failure and possible wheel loss, keep wheel bearings properly lubricated. Inspect the wheel bearings periodically and check for damage.

B. Tactics

NOTICE

Be sure to check the towing vehicle manufacturer's literature for recommendations on towing.

1. Install outside rear view mirrors on both sides of the towing vehicle to improve vision. Check the rear view mirrors at frequent intervals to be sure trailer and boat are riding smoothly.
2. Allow at least one car and trailer length between vehicles for each 10 mph. **DO NOT** tailgate.
3. Use low gear (on manual transmissions) when traveling up steep hills or over sand, gravel, or dirt roads.
4. Use care if shifting to a lower gear while traveling downhill. This could activate the trailer's surge brakes for the duration of the downhill run and cause overheating. Extended overheating could result in complete loss of the trailer brakes.

To help prevent overheating, slow down while approaching the crest of a hill and maintain a slow, controlled downhill speed. Apply brakes in short intervals to allow time between braking for the brakes to cool off.

5. When rounding turns on highways or streets, DO NOT cut corners. Also, travel slowly over railroad tracks.
6. If the trailer begins to “fishtail” when accelerating, reduce speed until it ceases. If the trailer “fishtails” again during acceleration, stop to investigate the cause of the problem. Check for improper trailer load and uneven weight distribution inside the boat. Check the winch line and tie-downs. Also check the tires for proper inflation or damage. If necessary, redistribute the load before continuing.

For additional information on trailering, refer to the “Boating Basics” manual included in the owner’s packet.

S - 5 MAINTENANCE

A. Care of Exterior Finish

When using the trailer, keep in mind the paint can scratch and become marred during normal use. In most cases, touch-up paint can be ordered. Please contact a Four Winns dealer for assistance.

Some maintenance is required to maintain the finish and minimize rusting. The trailer should be washed and rinsed with clean water immediately after each use. On galvanized trailers, rinse only with clean water. Depending upon use, waxing is recommended twice a year. Use paste wax designed for enamel paint.

B. Bunks

The bunks should be replaced if they are cracked, warped, or evidence of dry-rot is found. The replacement boards should be treated lumber of the same length and width.



CAUTION

DO NOT burn damaged or broken bunks. Toxic fumes will be released. Dispose of bunks properly.

C. Swivel Jack

Keep the swivel jack clean of dirt, tar, and mud. Lubricate every six months. The swivel jack’s inner ram should be lubricated with SAE 30 weight oil. The top cover may be removed to lubricate the gears with wheel bearing grease.

Replace all worn and damaged parts. ALWAYS use the manufacturer’s replacement parts. Replacement parts may be ordered through your Four Winns dealer.

For more information on maintenance, refer to the manufacturer’s literature included in the owner’s packet.

D. Brake Actuator & Coupling Assembly

When storing or parking your trailer, keep the brake actuator and coupling assembly (coupler) off the ground to prevent dirt buildup in the ball socket. Keep the coupler clean of dirt, tar, and mud. Lubricate the coupler with SAE 30 weight oil every six months or as often as necessary. Replace any worn or defective parts. If the coupler is damaged, contact your Four Winns dealer for replacement parts. DO NOT use a damaged or bent coupler assembly.

For more information on maintenance, refer to the manufacturer’s literature included in the owner’s packet.

NOTICE

The trailer should be set up at a slight angle to allow for water to drain aft in the boat.

E. Winch

The winch should be kept clean of dirt, ice, paint, etc., and the spur gears should have a film of grease on them at all times. Apply several drops of SAE 30 weight oil to the ratchet pawl mechanism, bushings and pinion shaft threads twice per season.

Replace any worn or damaged parts. For more information on maintenance, refer to the manufacturer’s literature included in the owner’s packet.

F. Lights

Inspect wiring for cuts or bare wire which could cause electrical shorts. Repair or replace defective wiring. Replace cracked or damaged lens and always carry spare bulbs. Replacement parts may be ordered through a Four Winns dealer.

G. Tie-downs

Replace frayed or damaged tie-downs. Periodically, lubricate the ratchet mechanism with a fine oil or silicone spray. Replacement parts may be ordered through a Four Winns dealer.

H. Wheels

Some maintenance is required to maintain the finish and retard rusting of painted rims. The wheels should be cleaned with dishwashing soap and water and rinsed with clean water immediately after each use. Waxing is recommended three to four times each year.

Aluminum wheel rims may be cleaned with dishwashing soap and water. However, cleaning products specifically for aluminum are available and can be used. Cleaners may be obtained from Four Winns dealers and your local auto parts stores. The Mag wheel manufacturer recommends a product by Priority One® called Pro-Long Aluminum/Chrome Wheel Protectant™. Galvanized rims should be rinsed only with clean water immediately after each use.

NOTICE

ALWAYS read the manufacturer's instructions on the label before using any product.

I. Brakes

Keep the actuator clean of dirt, tar, and mud. The actuator and internal parts should be lubricated at all times with SAE 30 weight oil. The hitch ball may be lubricated with automotive grease or lubricant made for hitch balls.

Periodically inspect the brake system for leaks. Check all hoses for cuts or wear. Replace all defective hoses. The master cylinder should be filled within 1/2 inch from the top of the reservoir.

At the beginning of each year, inspect the brakes for excessive wear, have linings replaced if necessary.

If the brakes need bleeding, consult your Four Winns dealer for assistance. If unavailable, a brake or auto repair facility can perform the repair.

Refer to the manufacturer's literature included in the owner's packet for additional information on the brake system.

J. Bearings

Wheel bearings and seals should be inspected at the same time as brakes. Have worn or defective parts replaced. Grease bearings and seals at this time and at the end of the boating season. Bearing Protectors should be greased three to four times a year. A grease fitting is provided.

Four Winns uses the Accu-Lube™ bearing protection system on its trailers. The Accu-Lube™ design is submersible and provides for grease flow that completely repacks and protects the bearings. This lubrication system disallows water entry, thus extending the life of the bearings, spindle and hub.

Lubricate the bearings as follows:

1. Remove the rubber plug.
2. Insert the grease gun into the grease fitting. Pump grease until old grease comes back out the front.
3. Remove old grease and reinstall rubber plug.

NOTICE

Most bearing failures are due to improper maintenance. Be sure to inspect bearings and seals as noted in Section S-6B and refer to the manufacturer's literature included with your trailer.

S - 6 AXLE INSPECTION & REPAIRS

As a general rule, repairs and maintenance should be performed by qualified servicing personnel. Our axle manufacturer recommends that a certified mechanic should be consulted on the following items:

1. Broken axle
2. Broken spring
3. Worn spring eye bushing parts
4. Sagging springs
5. Welding fatigue
6. Serious leakage of seal
7. Tire wear
8. Loose or worn suspension parts
9. All brake related adjustments, inspections and problems

A. Removal of Hub

The following instructions pertain only to trailers manufactured by Four Winns. To remove the hub to inspect the bearings and seals, refer to Figure S15 and the following instructions:

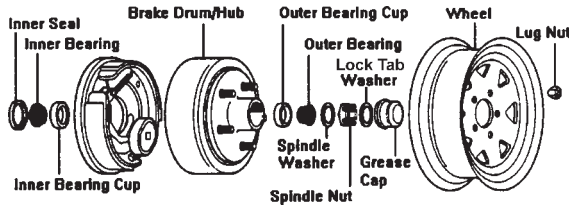

Figure S15: Axle Components

1. Remove lug nuts.
2. Remove wheel.
3. Remove grease cap.
4. Remove lock tab washer.
5. Unscrew the spindle nut counter clockwise.
6. Remove spindle washer.
7. Remove hub from spindle.

B. Bearing/Seal Inspection and Replacement

When inspecting bearings or seals:

1. Inspect the grease seal for damage, tears, or cracks. If there is no damage or leakage in not occurring, the seal is in good condition.

If the seal is torn or cracked, then it should be replaced. The seal can be pried out of the hub with a screw driver. Be sure to replace the seal using the recommended replacement parts. Parts can be obtained from your Four Winns dealer.
2. When inspecting the bearing, check for corrosion and wear. If any rust or wear exists on the bearing, then remove and replace with the recommended parts listed in the table above.

3. If the bearings are in good condition, repacking the grease should be done at this time. Hand pack each bearing individually using a premium water resistant wheel bearing grease.

C. Hub Reinstallation

1. To reinstall hub, reverse the procedures listed above.
2. It is important to tighten the spindle nut to approximately 50 ft. lbs. (12" wrench with full hand force). Loosen the nut then finger tighten.
3. Replace the cotter.
4. When reinstalling wheel, the following tightening procedure is recommended by the manufacturer:
 - a. Place wheel lug nuts on by hand to start.
 - b. Tighten initially to 15 - 20 ft. lbs. (Apply 20 pounds of pressure to wrench 12" long) using cross tightening sequence. Proceed to finish tightening to 85 ft. lbs. (Applying 85 pounds of pressure to wrench 12" long will yield 85 ft. lbs. of torque).
 - c. Re-torque after first 50 miles of use.

Refer to Section S-2G for additional information on wheel requirements.

PRE-LAUNCH AND UNDERWAY

T - 1 LAUNCH AND CRUISE CHECKLIST

- Get a current weather report. If the weather will not be favorable, postpone your trip.
- If your boat has been out of the water, check to see that all bilge water has drained out.
- Install hull drain plugs.
- Inspect the hull and propeller for damage. Excessive dirt or marine growth will effect your boat's performance and fuel efficiency.
- Check the electrical system and navigation lights.
- If your boat has been in the water, run the bilge pump until the flow of water stops.
- Check that all required safety equipment is on board and in good working condition. Examples include personal flotation devices (PFDs), horn, fire extinguisher, visual distress signals, etc. Take along a gallon of drinking water.
- Check that other important equipment is on board. Examples include mooring lines, anchor and line, tool kit, first aid kit, etc.
- Open engine compartment. Inspect for fuel odors and visible leaks in the fuel, oil, coolant, exhaust and power steering systems.
- Visually inspect engine for cracked hose, defective belts, or other signs of engine problems. Check engine oil and battery water levels. Check power steering fluid level. Check battery electrolyte range.
- Check fuel level. Fuel tanks should be filled to slightly less than capacity. Allow for fuel expansion.
- Check that all engine drains are closed (stern drives).
- Make sure navigation charts and equipment are on board.
- Check operation of steering system, navigation lights, and operation of horn.
- Make sure passengers and crew know what to do in case of an emergency and how to operate safety equipment.
- Make sure all required documents are on board.
- File a float plan with a responsible party ashore.
- Keep an eye on the weather. Be aware of possible changing conditions by monitoring local weather broadcasts prior to departure. The captain or first mate should personally monitor strong winds and electrical storms.
- Always keep accurate up-to-date charts of your boating area on board.

T - 2 FUELING**WARNING**

Do not smoke, extinguish all open flames, STOP all engines and other devices that could cause sparks, including the bilge blower. Do not use electrical switches or accessories. Shut OFF all stoves that may produce a spark or flame. Close all openings into the cabin area of the boat.

A. Recommendations**WARNING**

When fueling or having your boat fueled by an attendant, be sure the waste pump-out or fresh water fitting is not mistaken for the gas fill.

Although alcohol boosts the octane level of gasoline, it also attacks the rubber fuel distribution lines and even metal fuel system components. Alcohol will permeate most fuel hoses and other components such as fuel pump, gaskets and seals, and can also contribute to fuel system contamination.

The hoses we use in our boats are alcohol-resistant as are the materials used by the engine manufacturers. If only fuel containing alcohol is available, or the presence of alcohol is unknown, you must perform more frequent inspections for leaks and abnormalities. Any sign of leakage or deterioration requires your immediate attention. Refer to the engine manufacturer's recommendations on fuel type and octane ratings.

B. Preliminary Guidelines

1. Safely secure your boat to the dock.
2. Close all hatches, windows, doors and compartments to prevent accumulation of fuel vapors.
3. Ensure that a fire extinguisher is readily available.
4. Do not store fuel in areas that are not adequately ventilated.
5. Use only fuel lubricants recommended by the engine manufacturer.

C. Pumping Fuel**WARNING**

Follow engine manufacturer's recommendations for types of fuel and oil. Use of improper products can damage the engine and void the warranty.

1. Be sure to fuel in a well-lit area gasoline spills are unnoticeable under poor lighting or in the dark.
2. Remove the gas fill cover.
3. Insert the fuel supply nozzle, keeping it in contact with the fuel fill plate to guard against static produced sparks.
4. Stand away from the fuel tank vent and gas fill during fueling. Splashback may occur and can be an eye irritant and/or a fire hazard.
5. Avoid spillage. Wipe up any excess fuel immediately.
6. After pumping approximately 10 gallons of fuel into the fuel tank, inspect the engine and fuel tank area for any signs of leakage. If no leaks or other problems are detected, resume fueling.
7. Allow space at the top of the tank for thermal expansion.
8. If fuel cannot be pumped in at a reasonable rate, check for fuel vent blockage or a kink in the line.

D. After Fueling

1. Replace the gas fill cover and wipe up any fuel spilled. Discard rags used in a safe place ashore.
2. Open the engine compartment and all hatches, windows, doors and other compartments that were closed during fueling. Inspect these areas for the odor of fuel vapors and visible fuel leakage.

**WARNING**

Investigate and correct any sign of fuel leakage or indication of vapors before starting engine. Do not run blower or operate any electrical switch until problem is corrected. Fire or explosion may result.

T - 3 LOADING PASSENGERS AND GEAR

NOTE: All boats under 26 feet in length must have a capacity rating plate showing the recommended person capacity as well as the maximum capacity of the boat including persons, engine and gear.

When loading your boat, remember to distribute the load evenly. Keep the load low and do not overload. The capacity plate affixed to your boat states the maximum load capacity. The plate shows in pounds, the amount of persons and gear that the boat will safely handle under normal conditions. The U.S. Coast Guard establishes these load capacity ratings. Position passengers and gear so that the load is balanced.

When loading, always step into the boat, never board by jumping. Have someone on the dock pass your gear aboard. Secure all gear firmly so it doesn't move or in-

terfere with operation of the boat. Passengers should board the boat one-at-a-time and be seated. Passengers should remain seated during loading of the boat to maintain an even trim.

 **WARNING**

Passengers seated in the bow area should not obstruct the driver's vision.

IMPORTANT: Passengers are prohibited from riding on the bow with feet hanging over the side or ride while sitting on the stern, gunwales or seatbacks. The Coast Guard considers these acts to be negligent or grossly negligent operation. They are prohibited by law because falls from moving boats are a major cause of fatal recreational boating accidents.

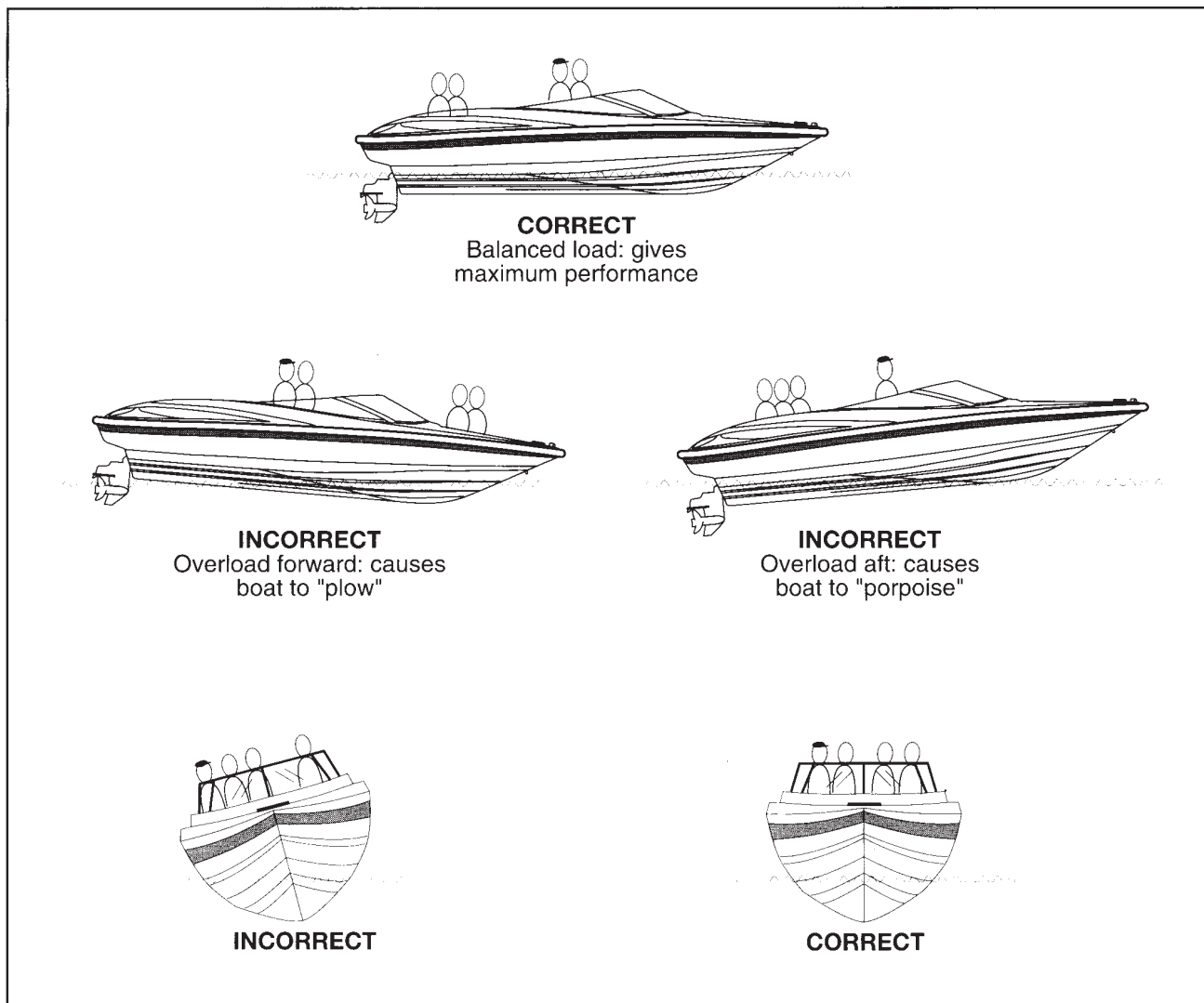

Figure 7.1: Loading Passengers and Gear

IMPORTANT: The presence of the capacity plate does not relieve the boat operator from the responsibility of using common sense or sound judgment. Turbulent waters and adverse weather conditions will reduce the maximum load capacity rating of the boat.

T - 4 STARTING PROCEDURES

The operation and maintenance manual supplied with your engine provides pre-start, starting and cold-starting instructions. The following information is merely a guide and not intended to explain in detail all starting procedures and instructions. Refer to your engine owner's manual.

A. Preliminary Checks

1. Secure boat to the dock before attempting to start engine. The boat should be kept secure until the engine is running and warmed up.
2. Operate the bilge pump until the flow of water stops.
3. Make sure the throttle is in the neutral position and stern drive or outboard is lowered into water.
4. Make sure passengers seated in the bow area do not obstruct the driver's vision.

B. Starting

 **DANGER**

To prevent excessive exposure and reduce the possibility of carbon monoxide accumulation in the cockpit areas of the boat, the operator should provide adequate ventilation in each of these areas. Utilize hatches, doors, windows and side vents to increase air movement. See Section B-2 for information about the dangers of Carbon Monoxide.

Notice: Additional starting information is located in Section A.

1. Check all electrical systems and navigation lights.
2. If your boat is equipped with an optional battery selector switch, turn the battery switch to 1, 2 or ALL position.
3. Attach the ignition interrupt lanyards securely to your body. In the event that you move away from the helm area and beyond the length of the lanyard, the engine will be turned off.

4. If your boat has fuel injection, turn the key to start the engine. Engine will not turn over if throttle is not in the neutral position.

If your boat does not have fuel injection, depress the engine warmup button to advance the throttle several times and leave it in the SLOW/START position. This will actuate the carburetor accelerator pump and feed fuel to the engine. Turn ignition key to START position.

5. When engine is cold, run engine approximately one (1) to two (2) minutes at fast idle speed (1200 to 1500 RPM). This step is not necessary with fuel injected engines.
6. Once engine has warmed up, check water temperature gauge to ensure engine temperature stays within optimum range. If temperature reading is abnormally high, stop engine immediately and inspect for cause of high reading.
7. With engine running, voltmeter should show a reading between 12 and 15 volts.
8. Check steering operation. Turn steering wheel full to port and starboard while observing outdrive movement.
9. Inspect for fuel odors and visible leaks in the fuel, oil, coolant, exhaust and power steering systems.
10. Make sure boat is securely moored to the dock and engine is idling. Then move the throttle forward and then aft and back to neutral to check for proper operation of the shifting motion. Be careful. Leave the engine in gear for only a second or two.

T - 5 MANEUVERING

 **WARNING**

Boat steering is not self-centering. Steering is effected by engine and propeller torque, trim tab setting, wave and current action and the speed of the hull through the water. Constant attention to steering is required for safe operation.

When all your pre-departure checks have been completed and the engine has warmed up, you will be ready to leave the dock. Take into account the amount of wind,

tide current, and other forces that may affect your maneuvering as you leave the dock. Idle speeds work best when maneuvering to and from the dock. Do not forget to release the mooring lines.

A. Leaving the Dock

You are ready to leave the dock after the engine has warmed up. Check all gauges for appropriate readings before casting off. If oil pressure is abnormally low or engine temperature is abnormally high, stop the engine immediately. Check voltmeter to be sure the charging system is working properly. Check for fuel, oil, and exhaust leaks. Correct the cause of any abnormal condition before getting underway.



WARNING

Make sure passengers sitting in the bow area do not obstruct the operator's vision when casting off or while underway.

After making sure your boat is ready, check wind, tide, current and other forces that will affect the way you maneuver your boat away from the dock. Throw mooring lines off to your boat. Shift your boat's engine into forward or reverse depending on whether you want to move the bow or the stern away from the dock first. Run your engine at a slow speed as you move away from the dock. If you move the bow out first, watch that the stern of the boat does not swing into the dock or a piling.

Once away from the dock, devote some time to learning how to maneuver. Practice docking using an imaginary dock. Practice stopping and reversing.

B. Stopping

Boats have no brakes. Stopping is accomplished by backing down on the throttle. Practice stopping maneuvers and learn early how your boat reacts. From forward motion, pull the throttle back towards NEUTRAL. Depending on your speed, the distance the boat travels until it comes to a complete stop will vary. The ability to measure the distance will only be acquired through experience.

Once the boat has slowed and motor is idling, place the shift in REVERSE. Gradually increasing reverse power with the throttle will allow you to stop the boat in a very short distance.

NOTE: A boat will not respond to steering in reverse nearly as well as it does when going forward, so do not expect to accomplish tight turning maneuvers when backing up.

Remember that all boats steer by the stern (the feeling is much like steering your automobile in reverse). This means that the stern of your boat will swing in the direction opposite to your turn. For example, when you turn the helm wheel to the left, the stern of your boat will swing in the direction opposite to your turn. This is especially important to keep in mind when docking, operating in close quarters with other boats, or when approaching a swimmer or downed skier in the water.

Always look behind you and to both sides of the boat before slowing down. Tell your passengers your intentions to allow them time to make adjustments to their balance or positions.

Slowly pull back on throttles, glance back and see if a large following wave is approaching the transom. If so give the engines a little throttle as the wave arrives to keep wave from rolling over the transom.

Once you have spent enough time practicing maneuvers and have a feel for how the boat handles, you will be ready to run in open waters.

T - 6 ACCELERATION



WARNING

Before accelerating to bring your boat on plane, be sure that the area in front of your boat is clear. The bow will rise out of the water momentarily before you plane and may temporarily obstruct your vision.

If you have never had your boat on plane before, choose a calm day for your first on plane experience. Never boat beyond your ability and experience.

Before bringing your boat "on plane", check the entire area to make sure you have a clear, safe path. As you throttle up to accelerate, your boat will increase its angle of trim, causing the bow to ride high. From a maximum angle, the boat will level out to its planing attitude with continued acceleration. This maximum angle is known as the "hump". Because visibility, handling, and performance are reduced, it is advisable to get "over the hump" as soon as possible. A few seconds at full throttle should get the boat over the hump and into its planing attitude.

After getting over the hump, accelerate until reaching a comfortable plane, then throttle down to cruising speed. This also will provide for better fuel efficiency.

T - 7 TRIMMING YOUR BOAT

A. Tilt/Trim Control Switches

NOTE: Trim refers to the angle of the lower unit in relation to the bottom of the boat. With respect to trimming, the words in, down, under, and forward, have the same meaning as do up, out, and aft.

1. The standard trim control switch is located on the control lever handle.
2. The switch controls the position of the stern drive or outboard motor. Proper trim is very important in boating.
3. In the case of low or heavy bow attitude, the boat tends to “plow” (Figure 7.2). The lower unit is trimmed too far under or forward. Trim the unit UP (out) to correct this situation.
4. If the bow is too high, the boat tends to “porpoise” (Figure 7.4). The drive unit is trimmed up or out too far. Trim DN (in) to correct.

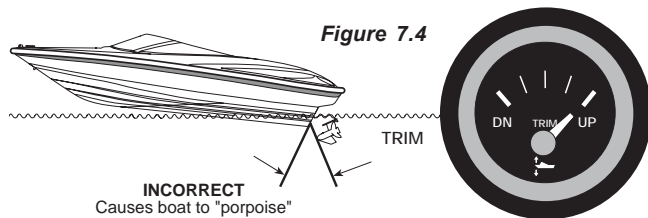
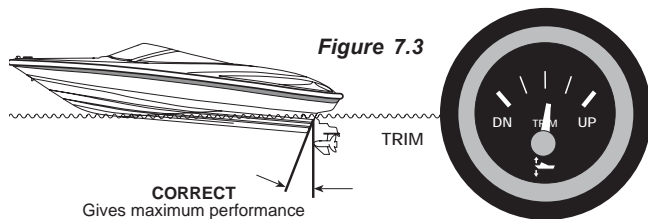
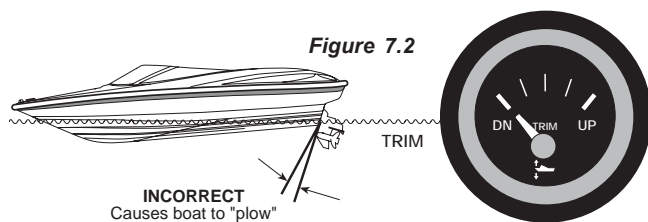

Figures 7.2-7.4: Trimming the Boat with Outdrive

5. A good practice is to get underway (especially when fully loaded or pulling a skier) with the unit trimmed all the way DN (under). After the boat is on plane, adjust the trim out slightly to obtain the proper bow attitude and engine speed.
6. Trim also affects propeller selection and fuel efficiency. All models should be “propped” to be in the upper half of the maximum RPM range with the boat lightly loaded and the drive trimmed up to maximum. This configuration allows the engine to operate within the recommended RPM range with a heavy load.

The power unit should never be trimmed up to a point where the propeller cavitates (or slips). A rapid increase in engine RPM's is evidence of cavitation. If this occurs accidentally while running at full throttle, immediately lower the drive trim and reduce the throttle until the slipping stops. If necessary, have your dealer reset the trim limit switch (if provided) to avoid overtrimming in the future.

If the prop slips at lower planing speeds, the drive may be trimmed too high. Immediately lower the drive unit until the prop grabs again to restore efficiency.

7. Trimming out, in addition to raising the bow, also lifts the boat higher, gaining speed because less hull is in the water.
8. The trailering position of some stern drives is controlled by a separate switch on the dash switch panel or throttle/shift control. **Do not activate this switch while engine is running. Doing so can severely damage the lower unit and engine.**

NOTE: Refer to the control instructions regarding the power trim controls installed on your boat.

T - 8 NAVIGATION LIGHTS

Although night activities are limited, cruising at night can be very pleasurable. It can also be dangerous if you don't pay close attention to water levels and obstacles. Be especially careful of shallow waters and watch for submerged debris, rocks and other obstacles in the water. Your navigation lights are intended only to prevent collision, not to improve your night vision. You may choose to use a spotlight instead.

NOTE: It is illegal to use your spotlight as a headlight. Use it only temporarily to check the position of your

boat and the surrounding area.

Your boat has one white (stern), one red (port) and one green (starboard) light. The stern light may be a removable pole light. To use the light, line up the two-prong plug in the pole with the receptacle in the base. Plug the light in, and lock it into place with lever/slide lock. When not in use, stow the light inside your boat for safekeeping. This light can be turned on or off at the helm.

Check lights for proper operation before heading out at night. You should also learn to identify the running light combinations for other vessels. We recommend that you participate in a boating safety course to further learn about navigation lights and safe boating practices.

The anchor lights and navigation lights are controlled by a switch at the helm. The anchor light switch allows you to turn on just the stern (white) light when anchored or moored. While underway, use the navigation light switch to turn on the stern (white), port (red) and starboard (green) lights. Lights are off when switches are in the OFF position.

T - 9 HAZARDOUS CONDITIONS

A. Storms

Storms sometimes appear without advance notice. Although weather information from meteorological observation and reporting stations is available, weather bureaus are known to have failures in their predictions or information gathering equipment. There is no substitute for a strong understanding of what action to take when the weather takes a turn for the worse. Many marinas fly weather signals. You should learn to recognize these signals and monitor your local weather forecasts before leaving port.

The present and forecasted weather conditions are of primary consideration, but a threat of possible storms should always be a concern. Observance of the following information will help in your safety afloat if storms do occur:

- Keep a watch on the horizon for approaching storm indicators.
- Turn radio ON. Dial in local weather station and monitor forecast. If your boat has a VHF radio, check the weather channels.

- The best possible situation is to return to a safe port if time allows.
- Close and secure all portals and hatches. Stow all loose gear below deck and tie down any gear required to remain on deck.
- Reduce speed as the seas build. Make sure all passengers are wearing their PFDs.
- If you lose power, keep the boat headed into the waves by rigging a sea anchor off the bow. If there is no sea anchor on board, use a canvas bucket or any object that will offer resistance.
- Radar reflectors (if installed on your boat) should be 18 inches diagonally and placed 12 feet above the waterline.

B. Fog

Fog is a result of either warm surface or cold surface conditions. You can judge the likelihood of fog formation by periodically measuring the air temperature and dew point temperature. If the spread (difference) between these two temperatures is small, you likely will incur a fog situation. Remember the following guidelines:

- Turn on running lights.
- As fog sets in, take bearings and mark your position on the chart while continuing to log your course and speed.
- Make sure all persons aboard are wearing their PFDs.
- If your boat has depth finding equipment, take sounding and match them with soundings on your charts.
- Station a person forward on the boat as a lookout.
- Reduce your speed. From time to time, stop engine and listen for fog signals.
- Sound the proper horn or fog bell at proper intervals to warn other boaters.
- If there is any doubt in continuing boat movement, anchor. Listen for other fog signals while continuing to sound the proper fog horn or bell for a boat at anchor.

C. Running Aground



WARNING

To prevent boat damage, DO NOT use deck hardware or water ski pylon for towing. Use a commercial towing service.

Operating in shallow water can present a number of hazards. Sand bars in narrow inlets are constantly shifting, making it difficult to mark them with buoys. Sometimes sand bars are indicated by waves as they form into breakers when passing over sand bars. In coastal areas, tides can change water levels by as much as 30 feet. Check with local marinas or Coast Guard stations for tide tables and current charts.

If your boat runs aground, first check persons aboard for injury. Then check for damage to the boat. If the drive unit strikes an underwater hazard, check for boat and drive unit damage. If the engine vibrates excessively after striking an underwater obstruction, it may indicate a damaged propeller. If vibration is noticeable, return to port slowly to prevent further drive and engine damage from an out-of-balance condition. Watch the temperature gauge to make sure you do not overheat the engine.

If the boat is not taking on any water, it may be possible to rock the boat by shifting the weight of the passengers and gear and by raising the drive unit while reversing the engine.

If you ground your boat on a sand bar, shut down the engine and seek help from another boater or radio for help. See your dealer as soon as possible, as sand ingested in the engine cooling system can cause major engine damage.

D. Warning Markers

It is a good idea to find out about hazardous areas and how they are marked by asking your local authorities.

- Boaters must also recognize the flag designs which indicate that scuba divers are present and keep well clear of the area.
- Watch for swimmers. Swimming areas may not be marked. Steer clear from the area and always remain alert.
- Distress flags indicate a fellow boater is in need of assistance.

- Navigation markers serve as a means of identifying navigable routes and indicate water hazards. Boaters should become familiar with navigation markers and stay within marked boundaries and clear of hazards.

T - 10 REACTING TO EMERGENCIES

Be prepared to deal with emergencies before they happen. Try to formulate a plan for each type of emergency in advance so that decisions can be made quickly and without hesitation. Precious moments lost can mean the difference between losing and saving a life.

A. Flooding

If your boat starts taking on water, activate the bilge pump immediately. Make sure all passengers are wearing their PFDs. Open the engine compartment, look for the cause of the flooding. Check all hoses, through hull fittings, seacocks and strainers. If flooding occurs as a result of collision or grounding damage, call for assistance and head for shore if possible.

B. Capsizing and Man Overboard

By far, the largest number of boating fatalities involve capsizing and falling overboard accidents. By being prepared ahead of time with an appropriate plan of action, you can greatly lower your chances and your passengers' chances of becoming seriously injured.

C. Capsizing

Wear PFDs or have them readily available at all times. If your boat capsizes, and others were on board, locate them and guide them to the safety of the hull. Even if the boat floats in an upside-down position, stay with it. The boat hull is much easier for rescuers to spot than a human head sticking out of the water. DO NOT attempt to swim ashore, it may be further than it looks.

D. Man Overboard

Think through and follow these procedures if someone in your boat falls overboard.

- Remember, every second counts, you must act fast.
- Move throttles to idle position immediately and yell "MAN OVERBOARD."

- Throw some floating object overboard immediately. Keep your required Type IV PFD accessible at all times for such an emergency.
 - Keep the person in the water in sight at all times. Have a passenger do nothing but watch the person. Do not go into the water to help the victim. One person in the water is enough trouble.
 - Circle around quickly, approaching into the wind and waves. When the person is alongside, put the engine in neutral and throw them a Type IV PFD with a line attached or extend a paddle or boat hook within his/her reach.
2. If the fire is small, attempt to put it out with your fire extinguisher. If the fire is in the engine compartment, turn off the bilge blower. Do not open the engine compartment. This feeds oxygen to the fire and may cause it to flare up.
 3. If the fire gets out of control, execute a distress signal and call for help if equipped with a ship-to-shore radio.
 4. All persons aboard should jump overboard and swim a safe distance away from the flames.

IMPORTANT: All persons aboard should know the location and proper operation of the fire extinguishers.

E. Collision

If a serious collision occurs, you should first check the condition of all passengers aboard, then inspect your boat to determine the extent of damage.

1. Make sure all persons aboard are wearing their PFDs.
2. If you need help and your boat has a ship-to-shore radio, first contact the U.S. Coast Guard (VHF Channel 16) or other rescue authorities immediately.
3. Prepare to assist the other vessel unless your passengers and/or boat are in danger.
4. If the bow of the other boat penetrated your boat's hull, prepare to block the opening once the boats are separated.
5. Shore up the hole with a spare PFD or bunk cushion from your boat.
6. While blocking the hole, trim the boat so that the hole is out of the water.

F. Fire

Most fires are caused by electrical problems or careless fueling practices. A fire on board your boat is a serious emergency. You must work quickly to implement safety procedures. If a fire occurs, immediately stop the engine.

1. Make sure all persons aboard are wearing their PFDs.

Guidelines

- Use only approved marine cooking and heating systems.
- Open flames demand constant attention.
- Keep flammable materials in approved containers in a overboard vented locker sealed from the interior of the boat.
- Ensure ventilation systems are unobstructed.
- Remove mooring covers before starting engine.
- Check the bilge for fuel leaks.
- Extinguish smoking materials carefully.
- Use special care with flame or high temperatures around urethane foam.
- Check cleaning products for flammability.
- Ventilate when cleaning or painting.
- Disconnect electrical system from its power source before performing maintenance.
- Replace breaker or fuse with same amperage device.
- Electrical appliances must be within rated amperage of boat circuits. Observe the boat carefully while the electrical system is being energized.

- Allow only a qualified marine electrician to service the boat's electrical system.

G. Medical Emergency

Accidents while boating can and may happen. Be prepared to handle these emergencies when they happen. Keeping a first aid kit and dry blankets on board can assist during these situations. It is also a good idea to contact your local Red Cross for information and training on first aid and CPR.

H. Propulsion Failure

Before you call for help regarding an engine or drive unit failure, it is a good idea to eliminate the possibility of simple problems. Turn off the engine and check to see that (1) there is fuel in the tank; (2) the engine cooling intakes on the outdrive are not clogged; (3) props are clean and free of weeds, netting, etc.; (4) no hoses are leaking; (5) there is oil in the engine.

Once you have checked out the possibilities listed above and find they are not the problem, call for help giving your position and a detailed description of your boat.

I. Control Failure

In the unlikely event of a shift/throttle failure, shut down the engine immediately. Carefully check the control connections in the engine compartment to see if they are secure. If not, try to locate the attaching hardware and reassemble. If that is not possible, try to use whatever is available such as paper clips, hair clips, tape, etc., to secure the connections. If a temporary repair is made, return to port at the slowest steerable speed and be prepared to take emergency action should the temporary repair fail also. Have your dealer make repairs before using the boat again.

J. Steering Failure

If a problem with the steering occurs, shut down the engine immediately. Check the connections to the drive unit in the engine compartment. Some boats have a push/pull cable while others will have hydraulic hose connections. With cable connections, check the attaching hardware and tighten it if necessary. If you have hydraulic hose connections, check to see if they are leaking. If so, tighten the connections and check the hydraulic fluid reservoir level. Most stern drives are power assisted and have their own hydraulic reservoir and engine mounted drive pump; check the level of reservoir

and drive pump belt. If the steering is not operating properly, do not operate the boat and call for assistance.

K. Additional Underway Information

- Always be aware of local laws on noise limits. Noise means engine noise, radio noise or even yelling by people on your boat. Good seamanship demands that you operate your boat quietly so as not to infringe on the rights of others. Don't use thru-transom exhaust unless you are well off shore.
- You are responsible for any damage or injury caused by your boat's wake. Observe no wake speed zone warnings. Operate your boat with regard for the safety of other boats and people in your boating area.
- Keep your engine well tuned to decrease exhaust hydrocarbon emissions that pollute the air and water.

T - 11 RETURNING TO SHORE

A. Docking

Always approach the dock slowly. Think before acting. If you are wondering whether your boat will fit in a space against a dock, remember that pilings are often (but not always) spaced 10 feet apart.

Remember that it is easier to control a boat in reverse because a boat steers from the stern. When backing into a slip, back so that bow swings into the wind if possible. You will have more control.

If possible, come in against the wind or current, whichever is stronger. Approach the dock at a 30-45° angle.

As the boat nears the dock, slowly swing parallel to it. Tie the bow line first; then the stern.

If wind or current is moving toward the dock, move parallel to the dock further out. Let the wind or current push you in. Tie the stern first, then the bow.

Use extreme caution if wind or current is from your stern. Back in towards the dock slowly at a slight angle with engine in slow reverse. Gently swing parallel. Tie stern first, then the bow.

If the weather looks bad, use spring-lines from the bow and stern to dock amidships of the boat. Tie up on the downwind side of the dock. If the wind is changeable, place fenders over the side between the boat and the dock.

B. Mooring

After you have positioned your boat next to the dock, you must secure it with mooring lines to keep it in position. Mooring lines must be long enough to secure your boat in any docking situation. For example, the length of the lines for a 16-foot runabout should be at least 15 feet. An eye splice at the end of each line works well with bow or stern cleats.

The mooring lines you will use most often are the bow line, the stern line, and spring lines as shown on Figure 7.5. Each line has a specific purpose. The bow line and the stern line secure your boat's bow and stern. The two spring lines keep your boat from moving forward or backward when you are moored alongside a dock.

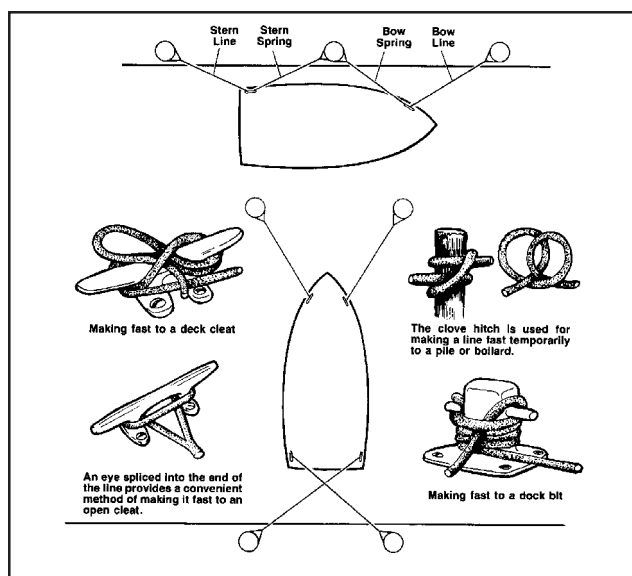

Figure 7.5: Mooring Lines

If you are mooring your boat for a short time, bow and stern lines may be the only lines you will need. If you are mooring your boat for a longer time or the currents are swift, you should use spring lines. The stern spring line leads from the boat's stern cleat forward to the piling or cleat on the dock. The bow spring line leads from the bow cleat aft to the dock.

If you are mooring your boat in a slip, bow and spring lines, port and starboard, will keep your boat in position.

NOTE: If tides are a consideration, be sure to leave slack in the lines to make up for the rise and fall of the water while your boat is docked.

GLOSSARY

ABAFT - Toward the rear of a boat.

ABEAM - At right angles to the keel of the boat.

ABOARD - On the boat.

ABREAST - Side by side.

ADRIFT - Loose, not on moorings or towline.

AFT - Moving toward the stern, you are going aft.

AGROUND - Stuck fast to the bottom.

AHEAD - In a forward direction.

ALEE - Away from the direction of the wind; opposite of windward.

ALOFT - Above the deck.

AMIDSHIPS - 1. An object or area midway between the bow and stern. 2. An object or area midway between the port side and the starboard side of a vessel.

AMPERE - The standard unit used to measure the draw of an electrical current.

ANCHOR RODE OR ROPE - The line (chain) connecting a vessel to its anchor.

ANCHOR BALL - A black, circular, day signal hoisted to show that a vessel is anchored. Replaced at dusk by the anchor light.

ASTERN - Anywhere behind the boat, a reverse direction, opposite of ahead.

ATHWARTSHIPS - A line, or anything else, running perpendicular to the fore-and-aft center line of a boat.

BATTEN - A strip of wood or metal used to secure tarpaulin(s) in place over a hatch. To batten down means to secure for rough weather.

BEAM - 1. The widest distance across a boat from the outside skin on one side to the outside skin on the other. 2. A transverse structural member that stiffens and supports a portion of the deck.

BEAM WIND - A wind blowing against the side of the vessel, perpendicular to the long axis of the vessel.

BILGE - The lowest interior area of a hull, used to collect water that has entered.

BILGE PUMP - A pump intended for removal of spray, rainwater, and the normal accumulation of water due to seepage and spillage; not intended for damage control.

BINNACLE - The stand or support for a magnetic compass occasionally used to mean helm.

BITT - A heavy and firmly mounted piece of wood or metal used for securing lines.

BLOCK - A wooden or metal case enclosing one or more pulleys and having a hook, eye, or strap by which it may be attached.

BOLLARD - A single post (wood, metal, or concrete) on a dock, pier, or wharf used to secure a vessel's lines.

BONDING - The electrical connection of exposed metallic, non-current carrying components to a common point on the main engine block.

BOW - The front end of the boat.

BOW LINE - A docking line leading from the bow.

BREAKER - A single breaking, plunging or spilling wave.

BREAKER LINE - The outer limit of the surf. However, all breakers may not be in a line. They can occur outside the breaker line.

BRIDGE - The main vessel control station.

BROACH - The turning of a boat parallel to the waves, subjecting it to possible capsizing.

BULKHEADS - The interior walls of a boat.

BULWARK - The side of a vessel when carried above the level of the deck.

BUOY - An anchored float used for marking a position on the water, a hazard, or a shoal.

CAPSIZE - To turn over.

CAPSTAN - A machine that moves a cylindrical device on a shaft for the purpose of hauling up an anchor.

CAST OFF - To let go.

CATAMARAN - A twin-hulled boat, with the hulls being side-by-side.

CHINE - The intersection of a boat's bottom and side. If this intersection is rounded, it is a "soft" chine. If the intersection is squared off, it is a "hard" chine.

CHOCK - 1. A fitting or hole in a railing or deck through which a mooring or anchor line is routed. 2. A wedge used to secure an item in place.

CIRCUIT BREAKER - A device used to interrupt an electrical circuit when current flow exceeds a predetermined level.

CLEAT - A double-ended deck fitting to which lines are secured; usually anvil-shaped.

COAMINGS - Raised lips around cockpits or hatches used to keep water from entering

COCKPIT - An exposed deck area (usually aft) that is substantially lower than the adjacent deck.

COMBER - A wave on the point of breaking. A comber has a thin line of white water on its crest, known as "feathering."

COMPANIONWAY - The steps or ladder leading downward from a deck.

COMPARTMENTS - Rooms divided by bulkheads.

COUNTER - The overhang at the stern of a boat.

CRADLE - A framework, generally made of wood, used to support a boat when it is out of the water.

CREST - The top of a wave, breaker or swell.

CUDDY - A small sheltered cabin in a boat.

CURRENT -1. The movement of water, 2. The flow of electrical charge.

DEAD AHEAD - Directly in front of the boat.

DEAD RECKONING - A plot of courses steered and distances traveled through the water.

DECK - A permanent covering over a compartment, hull or any part thereof.

DINGHY - A small, open boat used for ship to shore transportation.

DISPLACEMENT - The weight of water displaced by the hull of a vessel.

DISPLACEMENT HULL - A hull that "displaces" a volume of water equal to the weight of the boat. A hull designed to run in the water rather than on top of the water. When a displacement hull moves through the water, it pushes that water out of the way. Water will then flow around the hull and fill the "hole" the boat leaves astern.

DOCUMENTED VESSEL - Documented yachts have been specially registered with the U.S. Coast Guard. All documented yachts must have their name and home (hailing) port marked on some conspicuous place on the hull. Numbering is not required. Advantages include legal authority to fly the yacht ensign, privilege of recording bills of sale, and other instruments of title with federal officials, and preferred status for mortgages. Documentation does not exempt the unit from any State or Federal taxes. All safety and equipment regulations still apply.

DOLPHIN - A group of piles driven close together and bound with wire cables into a single structure.

DRAFT - 1. The depth of a boat from the actual water line to the bottom of the lowest part of the boat (e.g., the propeller tip or rudder). 2. The depth of water necessary to float a boat.

DROGUE - Any device streamed astern to check a vessel's speed, or to keep its stern up to the waves in a following sea.

DYE MARKER - A brightly colored chemical that spreads when released into water; normally used to attract attention.

EBB TIDE - A receding tide.

EVEN KEEL - To be floating evenly without listing to either side.

EXHAUST SYSTEM - The means by which the hot engine (or generator) exhaust gases are moved from the engine to an outboard port and then released into atmosphere.

EYE SPLICE - A permanent loop spliced in the end of a line.

FAST - Said of an object that is secured to another.

FATHOM - Six feet.

FENDER - A device (usually constructed of rubber or plastic) positioned so as to absorb the impact between vessels or dock.

FETCH - The unobstructed distance that the wind can blow over the water to create waves.

FLARE - 1. Outboard curve of the hull as it comes up the side from the waterline; the reverse of tumble home. 2. A pyrotechnic device used for emergency signaling.

FLAT - A small deck that is built below decks, specifically to support a piece of equipment.

FLEMISH - To coil down a line or rope on deck in a flat, circular, concentric arrangement.

FLOTSAM - Floating wreckage, trash or debris.

FLUKE - The palm of an anchor.

FOAM CREST - The top of the foaming water that speeds toward the beach after a wave has broken, commonly referred to as "white water."

FOLLOWING SEA - A sea (waves) moving in the same direction as a vessel.

FORE-AND-AFT - A line, or anything else, that runs parallel to the longitudinal center line of a boat.

FOREFOOT - The portion of a vessel's keel that curves upward to meet the stem.

FOREPEAK - A compartment in the bow of a boat.

FORWARD - Toward the bow.

FREEBOARD - The minimum vertical distance from the surface of the water to the gunwale.

FREQUENCY - The number of crests passing a fixed point at a given time.

FRONTS - Where opposing warm and cold air masses meet, generally producing a band of wet, stormy weather wherever they meet.

GALLEY - The kitchen area of a boat.

GALVANIC CORROSION - A potential electrical difference exists between dissimilar metals immersed in a conductive solution (e.g., salt water). If these metals touch or are otherwise electrically connected, this potential difference produces an electron flow between them. The attack on the less corrosion resistant metal is usually increased and the attack on the more resistant metal is decreased, as compared to when these metals are not touching.

GANGWAY - The area of a ship's side where people board and disembark.

GASKET - A strip of sealing material, usually rubber, set along the edge of a water or gas tight door, port, cover or hatch.

GELCOAT - The thin outer layer of pigmented plastic covering a fiberglass vessel.

GLAND - The movable part of a stuffing box, which when tightened, compresses the packing.

GROUND - Electrical term meaning the electrical potential of the earth's surface, which is zero.

GROUND SPEED - A vessel's speed made good over the earth's surface along a course or track.

GROUND TACKLE - The anchor, anchor rode, and other fittings that are used to secure a vessel at anchor or dockside.

GUNWALE - 1. The line where the upper deck and the hull meet. 2. The upper edge of a boat's side.

HALYARD - A line used to hoist a flag or pennant.

HATCHES - Cover on hatchways.

HATCHWAYS - Access ways through decks.

HARDTOP - A permanent cover over the cabin or cockpit.

HAWSER - A heavy rope or cable used for mooring or towing.

HEAD - A toilet or lavatory area.

HEADING - The direction that a vessel is going with reference to true, magnetic, or compass north.

HEADWAY - The forward motion of a vessel through the water.

HEAVE TO - To bring a vessel up in a position where it will maintain little or no headway, usually with the bow into the wind.

HEAVY WEATHER - Stormy weather with high seas and strong winds.

HEEL - To tip to one side.

HELM - The wheel or tiller that manually controls the boat's steering system.

HELMSMAN - The individual steering the vessel.

HIGHS - A center of pressure surrounded by lower pressure on all sides. Caused by a mass of cooler, sinking, drier air. This raises the area ground level air pressure and provides clear skies.

HULL - The main body of a boat.

INBOARD - 1. From either the port or starboard side of a boat toward the fore-and-aft centerline of a boat. 2. The dock side of a moored boat.

INLAND RULES - Nautical "Rules-of-the-Road" that apply in U.S. lakes, rivers, and coastal waters.

INTERNATIONAL RULES - Nautical "Rules-of-the-Road" that are in effect by international agreement to the high seas.

ISOBARS - Lines of equal air pressure that connect all the local points on a weather map. These lines are usually closed and define high or low pressure air masses.

ISOTHERMS - Isotherms are lines that are similar to isobars except that isotherms connect all the points that are of equal temperature.

JETSAM - Refuse that sinks when discharged overboard.

KEDGE(S) - One or more anchors set out from a grounded vessel, usually astern, to 1) keep it from being driven further aground and 2) to aid in refloating.

KEEL - 1. The centerline of a boat hull bottom running fore and aft, 2. The backbone of a vessel.

KNOT - 1. A maritime unit of speed equal to one nautical mile per hour (6076 feet). 2. A term for hitches and bends.

LANYARD - A short line made fast to an object to secure it.

LATITUDE - The measure of angular distance in degrees, minutes, and seconds, north or south of the equator.

LAZARETTE - Storage compartment in the deck at the stern.

LEADLINE - A weighted line used to take depth measurements.

LEE - The direction opposite that of the wind.

LEEWARD - Away from the wind.

LIST - A vessel that inclines to port or starboard.

LORAN - Long Range Navigation. An electronic system whereby a navigator can determine position regardless of weather.

LONGITUDINAL - Running lengthwise.

LOWS - A region of low atmospheric pressure. Hurricanes are extremely concentrated low pressure systems.

LUBBER LINE - A mark or line on the compass parallel to the keel indicating forward.

MAST - A spar that is set upright to support lighting, rigging, or sails.

MOORING - An arrangement for securing a boat to a mooring buoy or pier.

NAVIGATION LIGHTS - A set of red and green or white lights which must be shown by all vessels between dusk and dawn.

OVERHEAD - A ceiling or roof of a vessel.

OVERBOARD - Over the side of the boat.

OUTBOARD - 1. From the fore-and-aft centerline of a boat toward both the port and starboard sides. 2. The seaward side of a moored boat. 3. An engine that is mounted externally onto the transom of a boat.

PAINTER - A line to the bow of a small boat used for making fast.

PASSAGEWAY - A corridor or hallway aboard ship.

PENNANT - The line by which a boat is made fast to a mooring buoy; also pendant.

PERSONAL FLOATATION DEVICE (PFD) - A life preserver.

PIER - A loading platform that extends at an angle from the shore.

PILASTER - A rectangular structural support column that is an extension of the port and starboard aft cabin sides and which supports the hardtop and flybridge.

PILING - Support, or protection for wharves, piers, etc.

PITCH - 1. The vertical (up and down) motion of a bow in a seaway, about the athwartships axis. 2. The axial advance of a propeller during one complete revolution.

PITCHPOLING - A boat being thrown end-over-end.

PLANING HULL - At slow speeds, a planing hull will displace water in the same manner as a displacement hull. As speed is increased, the hull provides a lifting effect up onto the surface of the water.

POINT - One of 32 points of the compass that is equal to 11-1/4 degrees.

PORT - 1. Looking forward, the left side of a boat, 2. A harbor, 3. An opening for light or ventilation or passage of material in the side of a boat.

PORT BEAM - The left-center of a boat.

PORT BOW - Facing the bow, the front left side.

PORT QUARTER - Looking forward, a vessel's left rear section.

QUARTER - The sides of a boat aft of amidships.

QUARTERING SEA - Sea coming on a boat's quarter.

RED-RIGHT-RETURNING - A term for helmsmen that buoys and day markers are on the right when returning from seaward.

REEF - A shallow underwater barrier.

REEVE - To pass a line through a block or other opening.

RIDGES - High pressure fingers extending out from a high.

RODE - The anchor line or chain.

RUNNING LIGHTS - Lights required to be shown on boats underway between sundown and sunup.

RUDDER - A vertical plate for steering a boat.

SALON - The main social cabin on a vessel, usually the largest area, occasionally referred to as the deckhouse.

SCREW - A propeller.

SCUPPER - A drain from the edge of a deck that discharges overboard.

SEACOCK - A positive action shut-off valve connected directly to the hull seawater intake and discharge piping.

SERIES - A group of waves which seem to travel together and at about the same speed.

SHACKLE - A "U" shaped connector with a pin or bolt across the open end.

SHAFT - The long, round member that connects the engine or transmission to the propeller.

SHAFT LOG - A fitting at the hull bottom where the shaft connecting an engine to its propeller penetrates the hull. A shaft log permits the shaft to rotate while simultaneously preventing water from entering the hull.

SHEER - The top of the hull's curvature at the deck line from the bow to the stern.

SHEER STRAKE - The upper edge of the hull, immediately below the deck.

SHEET BEND - A knot used to join tow ropes.

SHOAL - An area of shallow water.

SILENCER - A baffled chamber installed in an exhaust system to reduce the noise.

SOLE - Term for deck, cabin or cockpit floor.

SPAR - A general term for booms, masts, yards etc.

SPRING LINE - A pivot line used in docking, undocking, or to prevent the boat from moving forward or astern while made fast to a dock.

STARBOARD - Looking forward, the right side of a boat.

STARBOARD BEAM - The right-center of a boat.

STARBOARD BOW - When facing the bow, the front right side.

STARBOARD QUARTER - When looking forward, the right rear section of the boat.

STEERAGEWAY - The lowest speed at which a vessel can be controlled by the steering wheel.

STEM - The leading edge of a boat's hull.

STERN - The back of a boat.

STRINGER - A fore and aft continuous member used to provide a vessel longitudinal strength.

STRUT - A propeller shaft support that is below the hull.

SUMP - A pit or well into which water is drained.

SUPERSTRUCTURE - Deck houses and other structures extending above the deck.

THWART - A seat or brace running laterally across a boat.

THWARTSHIPS - At right angles to the centerline.

TILLER - A bar or handle for turning a boat's rudder, or motor.

TOPSIDE - To go up to the top deck.

TRANSOM - The stern cross-section of a square sterned boat.

TRANSVERSE - Across the vessel; athwartships.

TRIM - Fore and aft balance of a boat.

TROUGH - 1. The valley that exists between waves. 2. A trough is the opposite of a ridge in that it is an elongated low-pressure area extending out from a low. A trough normally indicates unsettled weather.

TUMBLE HOME - The opposite of flare. The shape of the hull as it moves outboard going down from the gunwale to the waterline or chine.

UNDERWAY - Movement. Usually referring to a vessel proceeding forward.

V-BOTTOM - A hull with the bottom section in the shape of a "V."

V DRIVE - A drive system that has the output of the engine facing forward and coupled to a transmission. The prop shaft is then coupled to the transmission.

WAKE - Moving waves, track or path that a boat leaves behind it when moving across the water.

WATER LINE - The line of the water on the hull when the vessel is afloat.

WATCH - A 4 hour duty period while at sea.

WAVES - Waves are periodic disturbances of the sea's surface, caused by wind, seaquakes, and the gravitational pull of the moon and the sun.

WAVE GRADIENT - A wave's slope or angle from trough to crest with respect to the horizon.

WAVE HEIGHT - From the bottom of a wave's trough to the top of the crest.

WEATHER DECK - A deck with no overhead protection.

WET EXHAUST - This term refers to an exhaust system where the cooling seawater is mixed with the exhaust gases just after the riser. This mixture is then ejected through the drive or ports located in the transom or hull sides.

WHARF - A man-made structure bounding the edge of a dock and built along the shoreline.

WHIPPING - The act of wrapping the end of a piece of rope with small line, tape or plastic to prevent it from fraying.

WINDLASS - A device used to raise and lower the anchor.

WINDWARD - Toward the direction from which the wind is coming.

YAW - 1. To swing off course, as when due to the impact of a following or quartering sea. 2. Any motion about a vertical axis.

FLOAT PLAN

Copy this page and fill out before going boating. Leave the completed copy with a reliable person who can be depended upon to notify the Coast Guard, or other rescue organization, should you not return as scheduled. DO NOT file this plan with the Coast Guard.

Name _____ Telephone _____

Description of Boat _____ Type _____ Color _____ Trim _____

Registration Number _____

Length _____ Name _____ Make _____

Four Winns® Hull Identification Number _____

Other Information _____

Persons Aboard: Name	Age	Address	Telephone

Engine Type _____ HP _____

Number of Engines _____ Fuel Capacity _____

Survival Equipment:

PFDs _____ Flares _____ Mirror _____

Smoke Signals _____ Flashlight _____ Food _____

Paddles _____ Water _____ Anchor _____

Raft or Dinghy _____ EPIRB _____ Sea Anchor _____

Navigation Equipment:

Compass _____ Loran _____ GPS _____ Radar _____

Radio: Yes _____ No _____ Type _____ Frequency _____

Phone: Yes _____ No _____ Phone Number _____

Destination _____ Estimated Time of Arrival _____

Expected to Return By _____

AutoType _____ License No. _____ Where _____

If not returned by _____ call the Coast Guard, or _____

Local Marine Authority

Coast Guard Telephone Number: _____

Local Marine Authority Telephone Number: _____

FUEL LOG

DATE	HOURS RUN	FUEL (GAL.)	RANGE (MILES)	RPM	MPH	GPH

FUEL LOG

DATE	HOURS RUN	FUEL (GAL.)	RANGE (MILES)	RPM	MPH	GPH

FUEL LOG

DATE	HOURS RUN	FUEL (GAL.)	RANGE (MILES)	RPM	MPH	GPH

SERVICE LOG

DATE	HOURS	MAINTENANCE PERFORMED

SERVICE LOG

DATE	HOURS	MAINTENANCE PERFORMED

SERVICE LOG

DATE	HOURS	MAINTENANCE PERFORMED

SERVICE INFORMATION

BOAT MODEL	
HULL IDENTIFICATION NUMBER	
ENGINE MODEL	
ENGINE SERIAL NUMBER	
DRIVE MODEL	
DRIVE SERIAL NUMBER	
PROPELLER DIAMETER	
PROPELLER PITCH	
PROPELLER PART NUMBER	
OIL FILTER NUMBER	
BOAT COLOR	
COCKPIT UPHOLSTERY COLOR	
CABIN UPHOLSTERY COLOR	
FUEL CAPACITY	
FUEL: ESTIMATED AVG. GALLON/HR USAGE	
IGNITION KEY NUMBER	
GLOVE BOX KEY NUMBER	
COMPANIONWAY KEY NUMBER	
TRAILER MODEL	
TRAILER COLOR	
TRAILER SERIAL NUMBER	
TRAILER TIRE SIZE & MANUFACTURER	
SELLING DEALER	
ADDRESS	
CITY & STATE	
PHONE NUMBER	
MISCELLANEOUS	

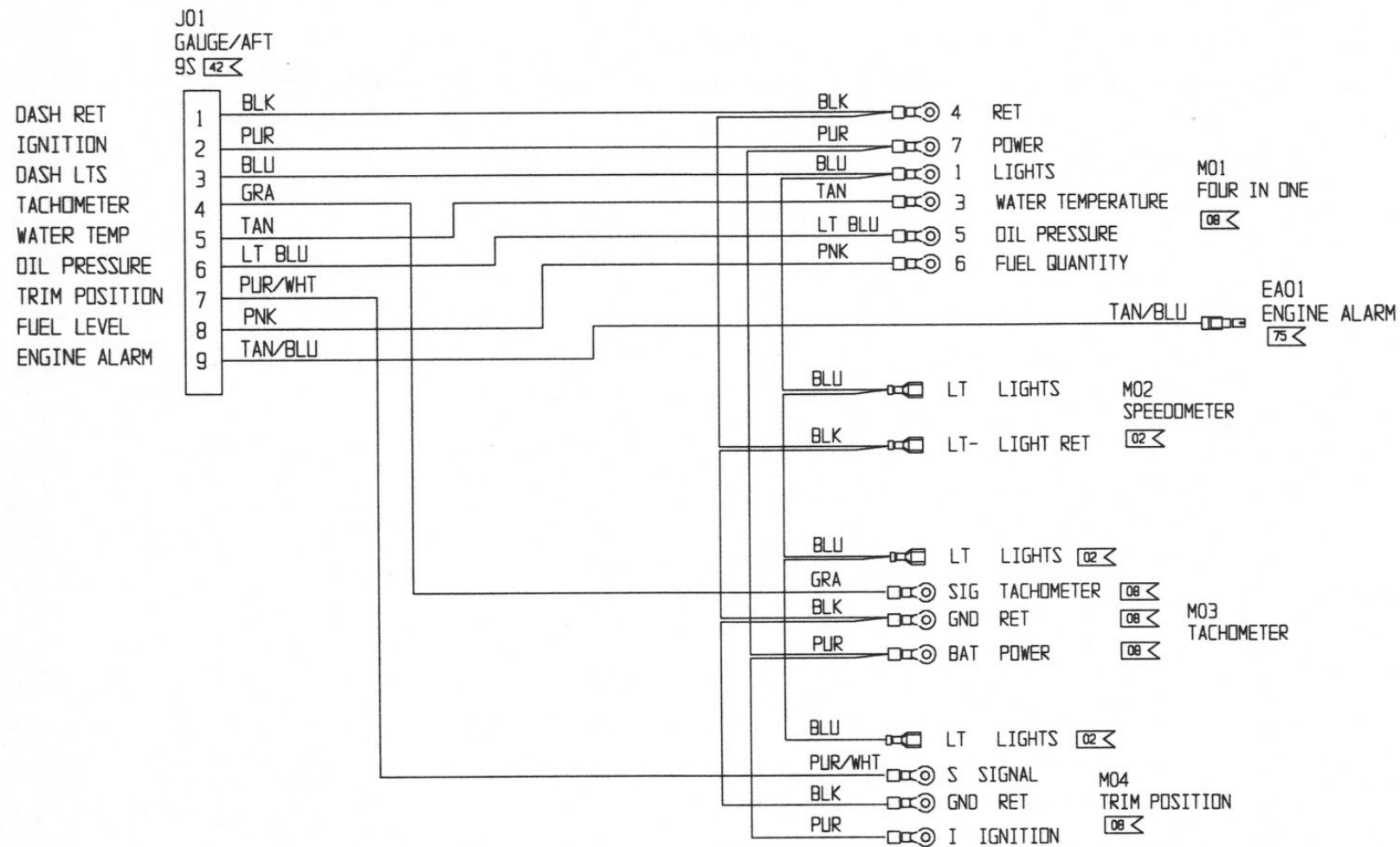

032-2437
SHROUD, DASH, BLANK 170F/194FS

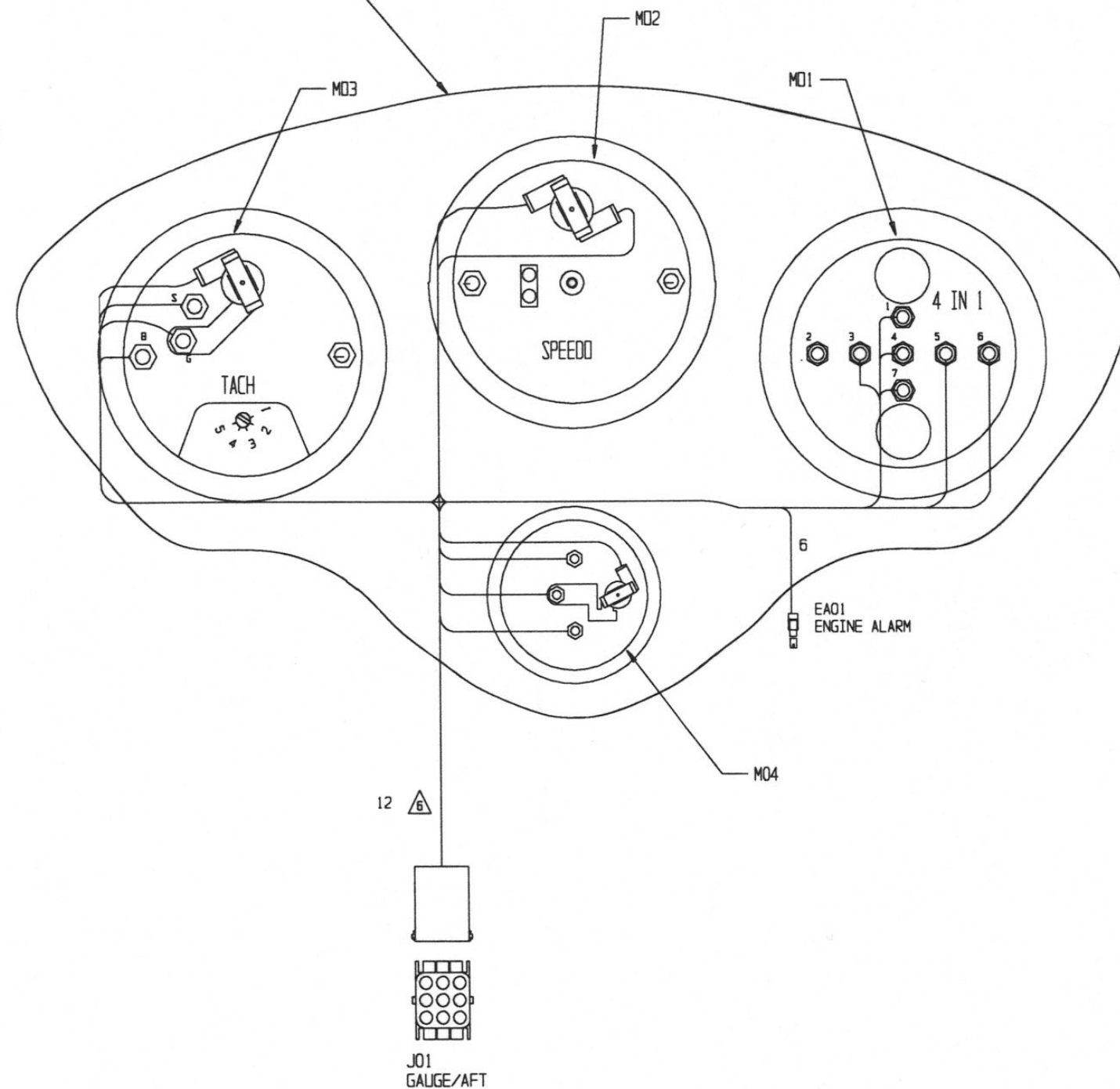

FOUR WINNS PARTS LIST

ITEM	PART NUMBER	QUANTITY	DESCRIPTION	FUNCTION	MANUFACTURER
-	028-0454	4	RECEPT, FASTON, .250, 16-14	02	AMP
-	028-0189	12	TERM, RING, PG #8, 16-14	08	AMP
-	028-0177	9	SOCKET, UMNL, 18-14	42	AMP
-	028-1823	1	TERM, BULLET, FEMALE, INS, .156, 16-14	75	MOLEX
-	032-2437	1	SHROUD, DASH BLANK 170F/194FS	-	-
J01	028-0443	1	RECEPT, UMNL, 9 CKT	GAUGE/AFT	AMP
M01	024-0438	1	GAUGE, 4 IN 1, GF0002	-	FARIA
M02	024-0433	1	GAUGE, SPEED (50MPH), SE9473	-	FARIA
M03	024-0434	1	GAUGE, TACH (6000RPM), TC9679	-	FARIA
M04	024-0436	1	GAUGE, TRIM, GP9317	-	FARIA

194 FUNSHIP STARBOARD DASH SHROUD ASSEMBLY

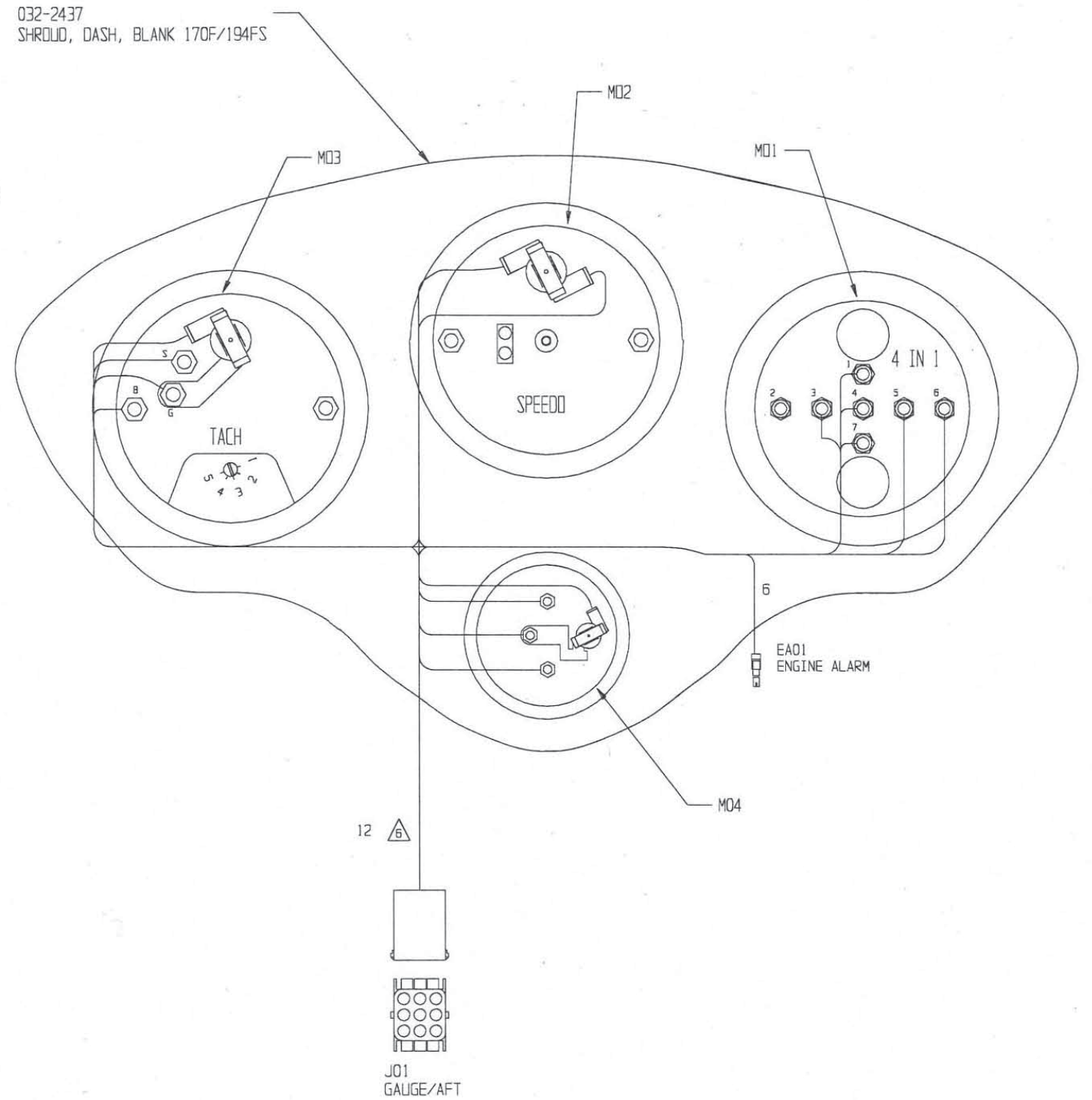
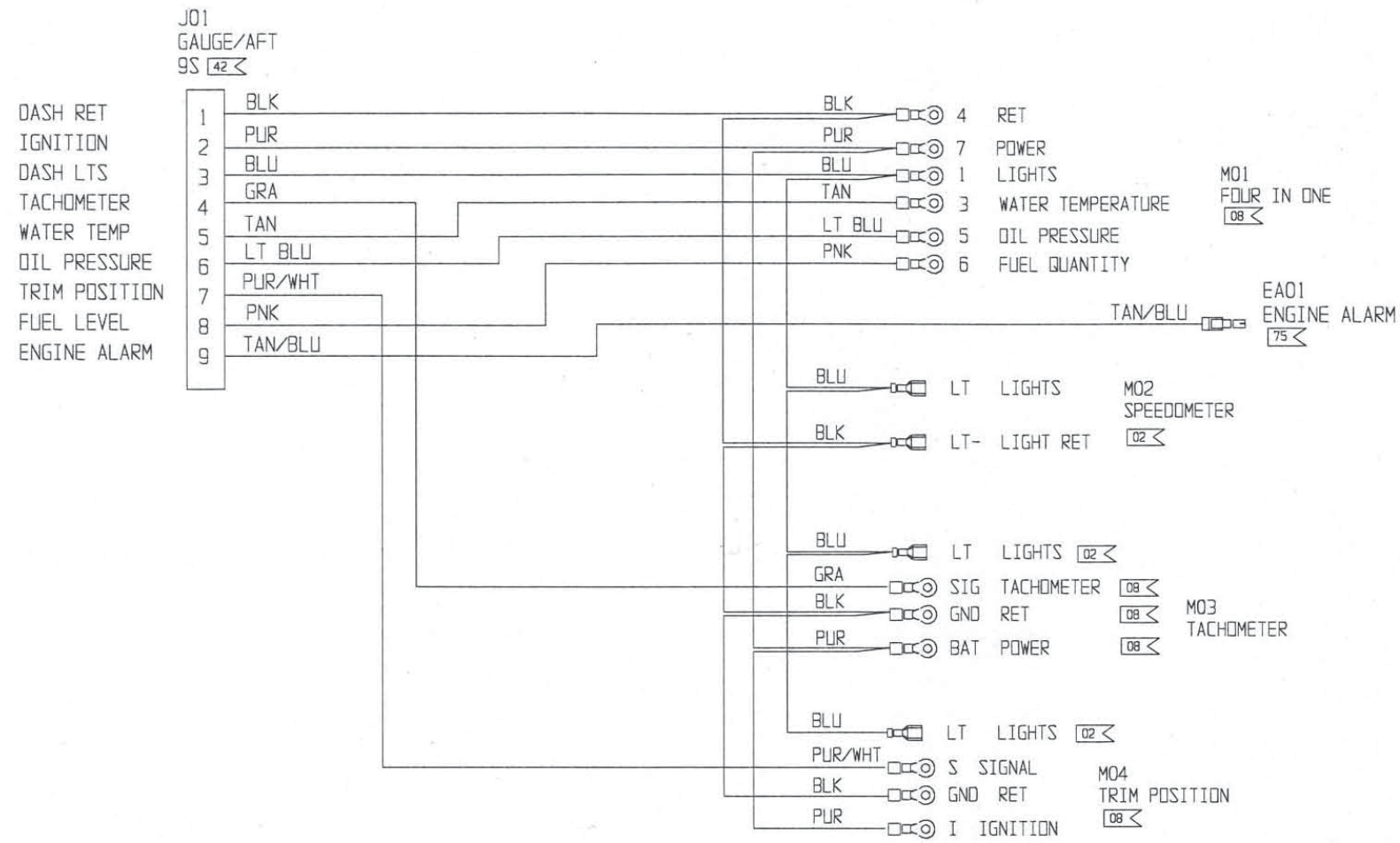

FOUR WINNS PARTS LIST

ITEM	PART NUMBER	QUANTITY	DESCRIPTION	FUNCTION	MANUFACTURER
-	028-0454	4	RECEPT, FASTON, .250, 16-14	02	AMP
-	028-0189	12	TERM, RING, PG #8, 16-14	08	AMP
-	028-0177	9	SOCKET, UMNL, 18-14	42	AMP
-	028-1823	1	TERM, BULLET, FEMALE, INS, .156, 16-14	75	MOLEX
-	032-2437	1	SHROUD, DASH BLANK 170F/194FS	-	-
J01	028-0443	1	RECEPT, UMNL, 9 CKT	GAUGE/AFT	AMP
MO1	024-0524	1	GAUGE, 4 IN 1, FARIA#GF0223	-	FARIA
MO2	024-0523	1	GAUGE, SPEED (65MPH), FARIA#SE9972	-	FARIA
MO3	024-0526	1	GAUGE, TACH 6000 W/HOUR, FARIA#TCH239	-	FARIA
MO4	024-0529	1	GAUGE, TRIM, FARIA#GP7766	-	FARIA

194 FUNSHIP LS STARBOARD DASH SHROUD ASSEMBLY

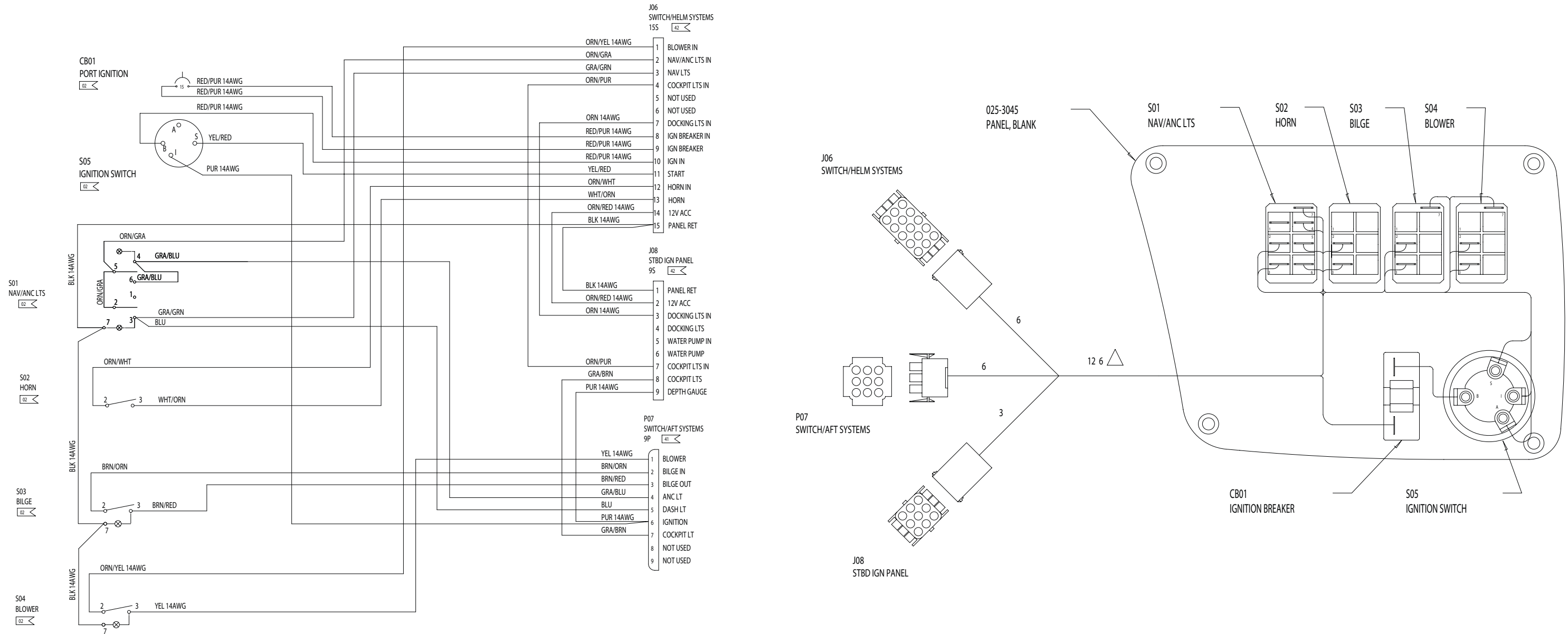

FOUR WINNS PARTS LIST

ITEM	PART NUMBER	QUANTITY	DESCRIPTION	FUNCTION	MANUFACTURER
-	028-0177	19	TERM,FASTON,,250,18-14	02	AMP
-	028-0390	7	PIN,UMNL,18-14	41	AMP
-	028-0454	19	SOCKET,UMNL,18-14	42	AMP
-	025-3045	1	PANEL,BLANK, PORT IGN SW	-	-
J06	028-0446	1	RECEPT,UMNL,15CKT	SWITCH/HELM	AMP
J08	028-0443	1	RECEPT,UMNL,9CKT	STBD IGN PANEL	AMP
P07	028-0449	1	PLUG,UMNL,9CKT	SWITCH AFT	AMP
CB01	028-0467	1	BREAKER,15A	IGNITION BREAKER	MP
S01	028-0504	1	SWITCH,DPDT,(ON-OFF-ON),CONT III	NAV LTS	CARL SW
S02	028-0456	1	SWITCH,SPST,(ON)-OFF,CONT III	HORN	CARL SW
S03	028-0457	1	SWITCH,SPST,ON-OFF,CONT III	BILGE	CARL SW
S04	028-0457	1	SWITCH,SPST,ON-OFF,CONT III	BLOWER	CARL SW
S05	028-1286	1	SWITCH,IGNITION,I/O	IGNITION SWITCH	GENERAL

194 FUNSHIP PORT IGNITION/SWITCH PANEL ASSEMBLY

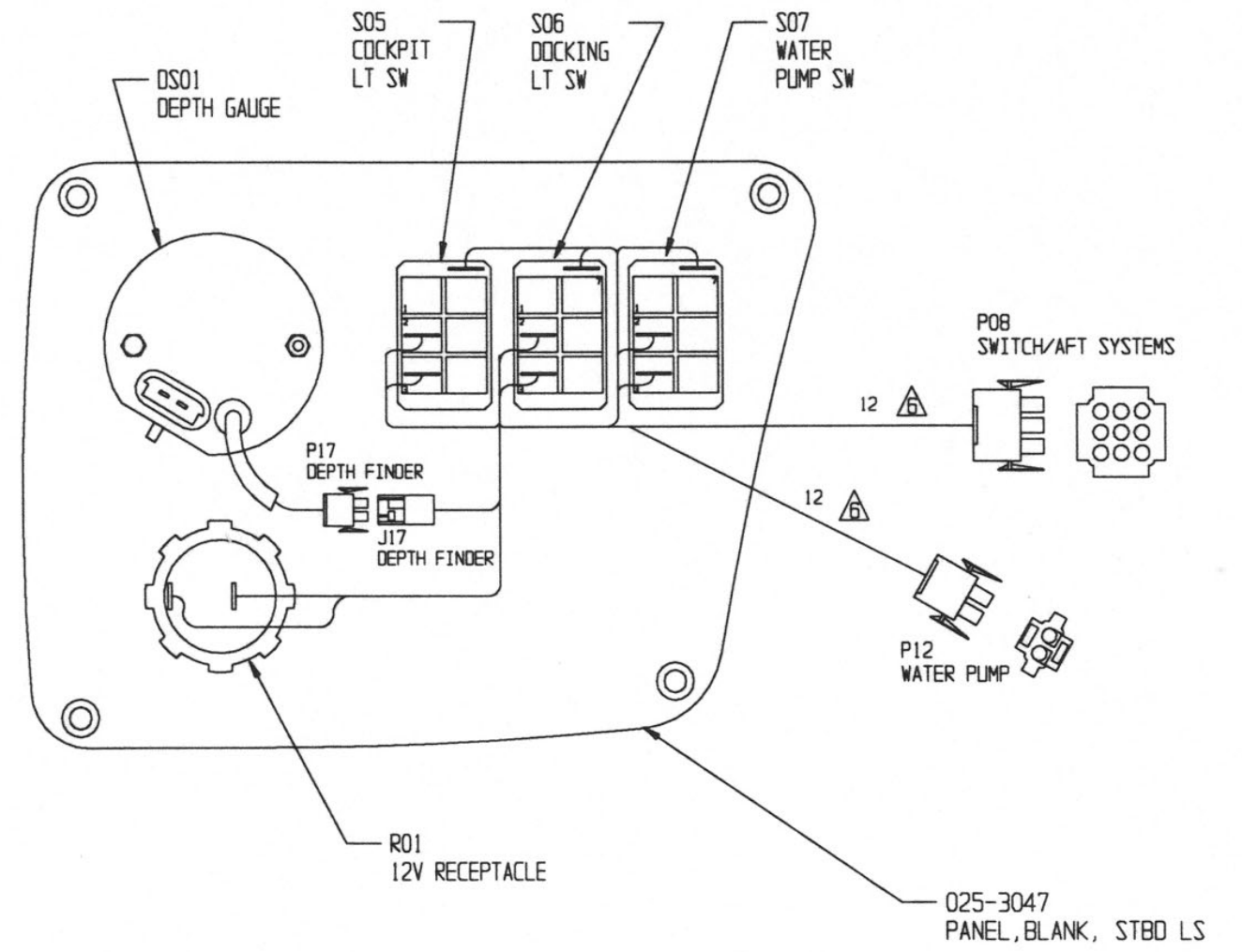
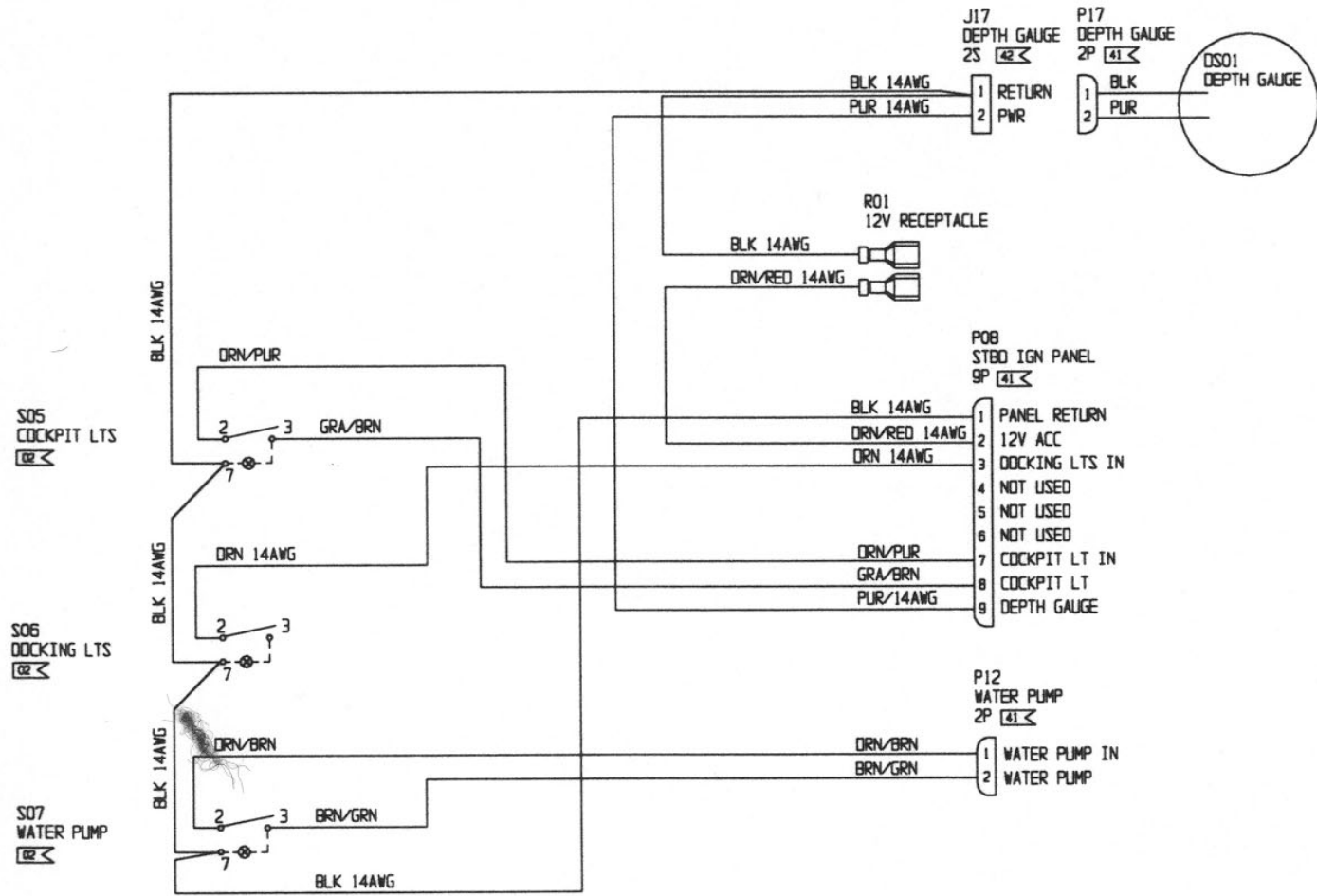

FOUR WINNS PARTS LIST

ITEM	PART NUMBER	QUANTITY	DESCRIPTION	FUNCTION	MANUFACTURER
-	028-0177	10	TERM, FASTON, .250, 18-14	02	AMP
-	028-0390	10	PIN, UMNL, 18-14	41	AMP
-	028-0454	2	SOCKET, UMNL, 18-14	42	AMP
-	025-3047	1	PANEL, BLANK, STBD LS	-	-
P08	028-0449	1	PLUG, UMNL, 9CKT	STBD IGN PANEL	AMP
P12	028-0447	1	PLUG, UMNL, 2CKT	WATER PUMP	AMP
P17	028-0447	1	PLUG, UMNL, 2CKT	DEPTH GAUGE	AMP
J17	028-0441	1	RECEPT, UMNL, 2CKT	DEPTH GAUGE	AMP
S05	028-0457	1	SWITCH, SPST, ON-OFF, CONT III	COCKPIT LT	CARL SW
S06	028-0457	1	SWITCH, SPST, ON-OFF, CONT III	DOCKING LT	CARL SW
S07	028-0457	1	SWITCH, SPST, ON-OFF, CONT III	WATER PUMP	CARL SW
R01	028-1100	1	RECEPTACLE, 12VDC	12V ACCESSORY	GENERAL

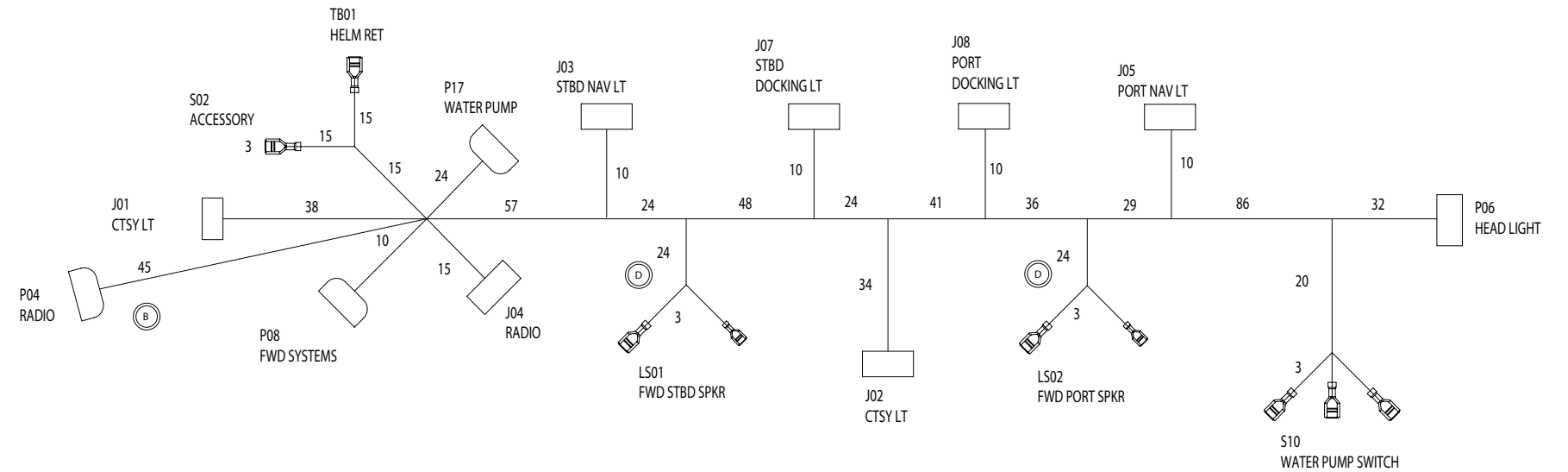
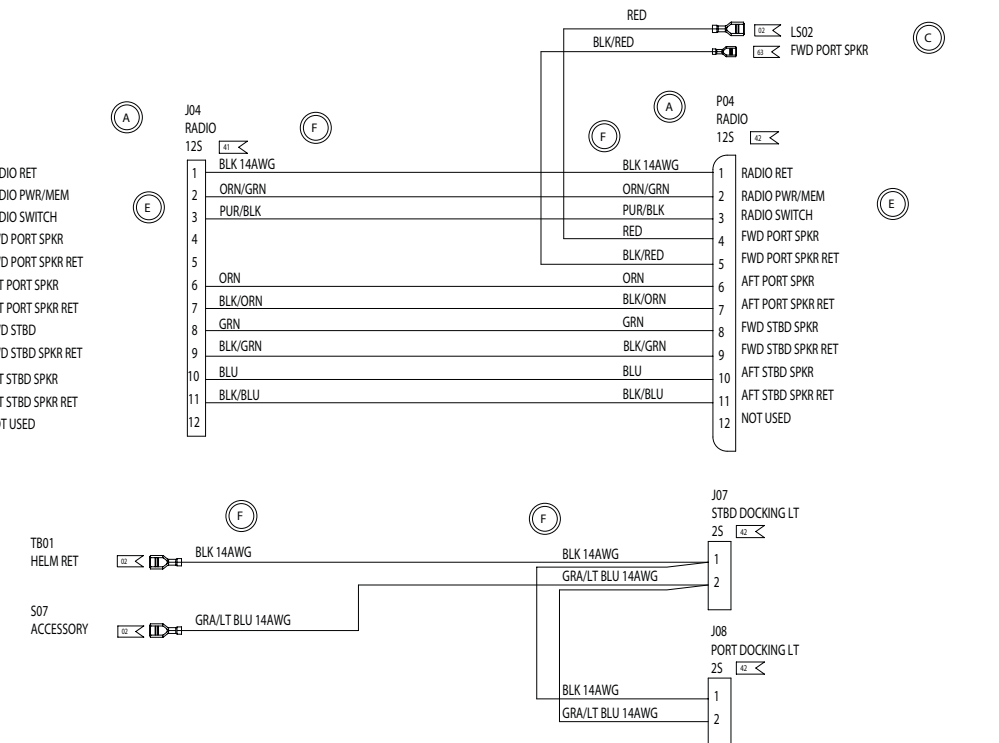
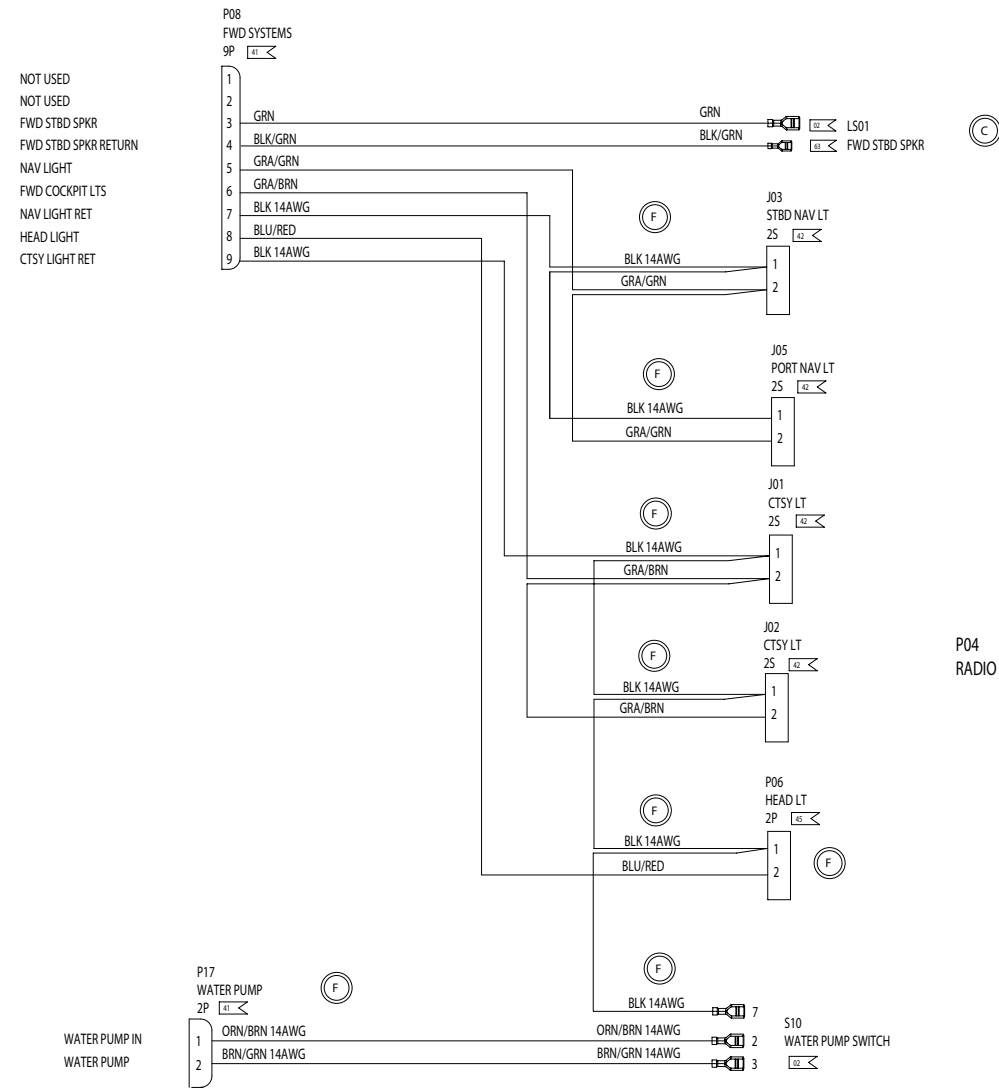

FOUR WINNS PARTS LIST

ITEM	PART NUMBER	QUANTITY	DESCRIPTION	FUNCTION	MANUFACTURER
-	028-0177	7	TERM,FASTON,,250,18-14	02	AMP
-	028-0390	18	PIN,UMNL,18-14	41	AMP
-	028-0454	23	SOCKET,UMNL,18-14	42	AMP
-	028-0159	2	SOCKET,CMNL,20-14	45	AMP
-	028-1248	2	TERM,FASTON,,205,18-14	63	AMP
J01	028-0441	1	RECEPT,UMNL,2 CKT	CTSY LT	AMP
J02	028-0441	1	RECEPT,UMNL,2 CKT	CTSY LT	AMP
J03	028-0441	1	RECEPT,UMNL,2 CKT	STBD NAV LT	AMP
J04	028-0445	1	RECEPT,UMNL,12 CKT	RADIO	AMP
J05	028-0441	1	RECEPT,UMNL,2 CKT	PORT NAV LT	AMP
J07	028-0441	1	RECEPT,UMNL,2 CKT	STBD DOCKING LT	AMP
J08	028-0441	1	RECEPT,UMNL,2 CKT	PORT DOCKING LT	AMP
P04	028-0451	1	PLUG,UMNL,12,CKT	RADIO	AMP
P06	028-0161	1	HOUSING,SCKT 2CKT	HEAD LT	AMP
LS01	-	REF	SPEAKER	FWD STBD SPKR	-
LS02	-	REF	SPEAKER	FWD PORT SPKR	-
P17	028-0447	1	PLUG,UMNL,2 CKT	WATER PUMP	AMP
P08	028-0449	1	PLUG,UMNL,9 CKT	FWD SYSTEMS	AMP
S02	028-0457	REF	SWITCH,SPST,CONT III	DOCKING LTS SW	-
S10	028-0457	REF	SWITCH,SPST,CONT III	WATER PUMP SW	-
TB01	-	REF	HELM RET	HELM RET	-

194 FUNSHIP FORWARD SYSTEMS HARNESS ASSEMBLY

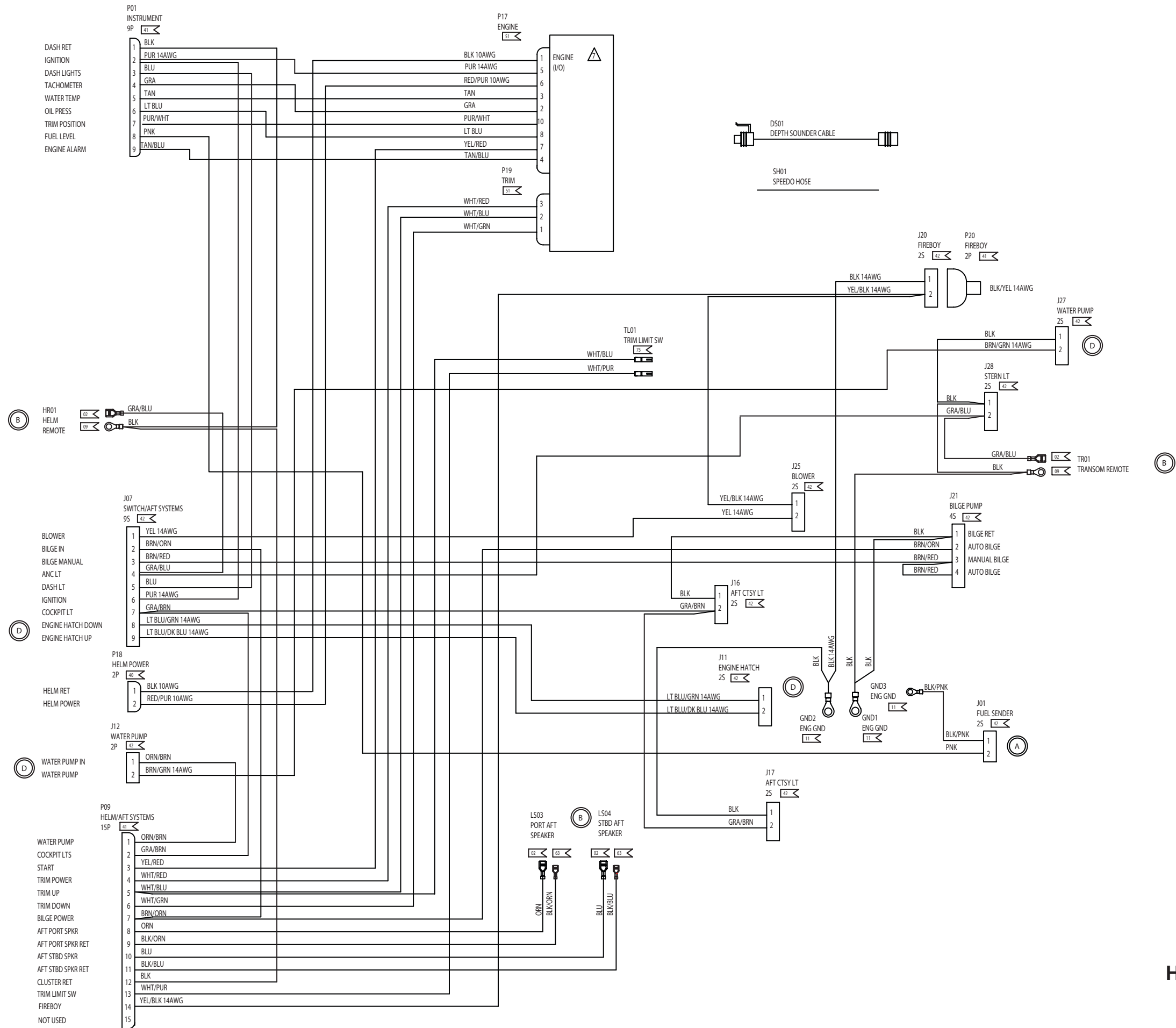

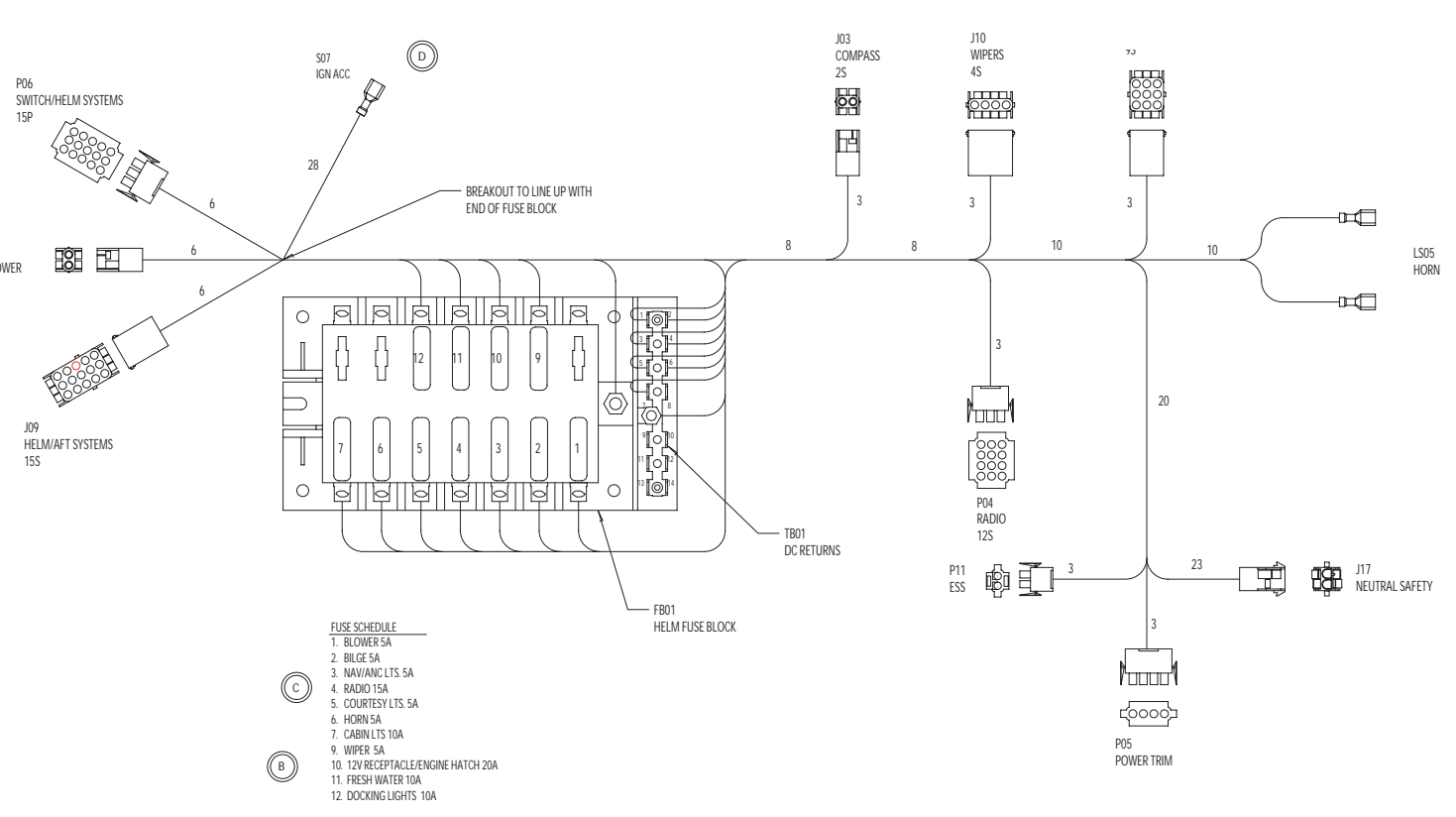
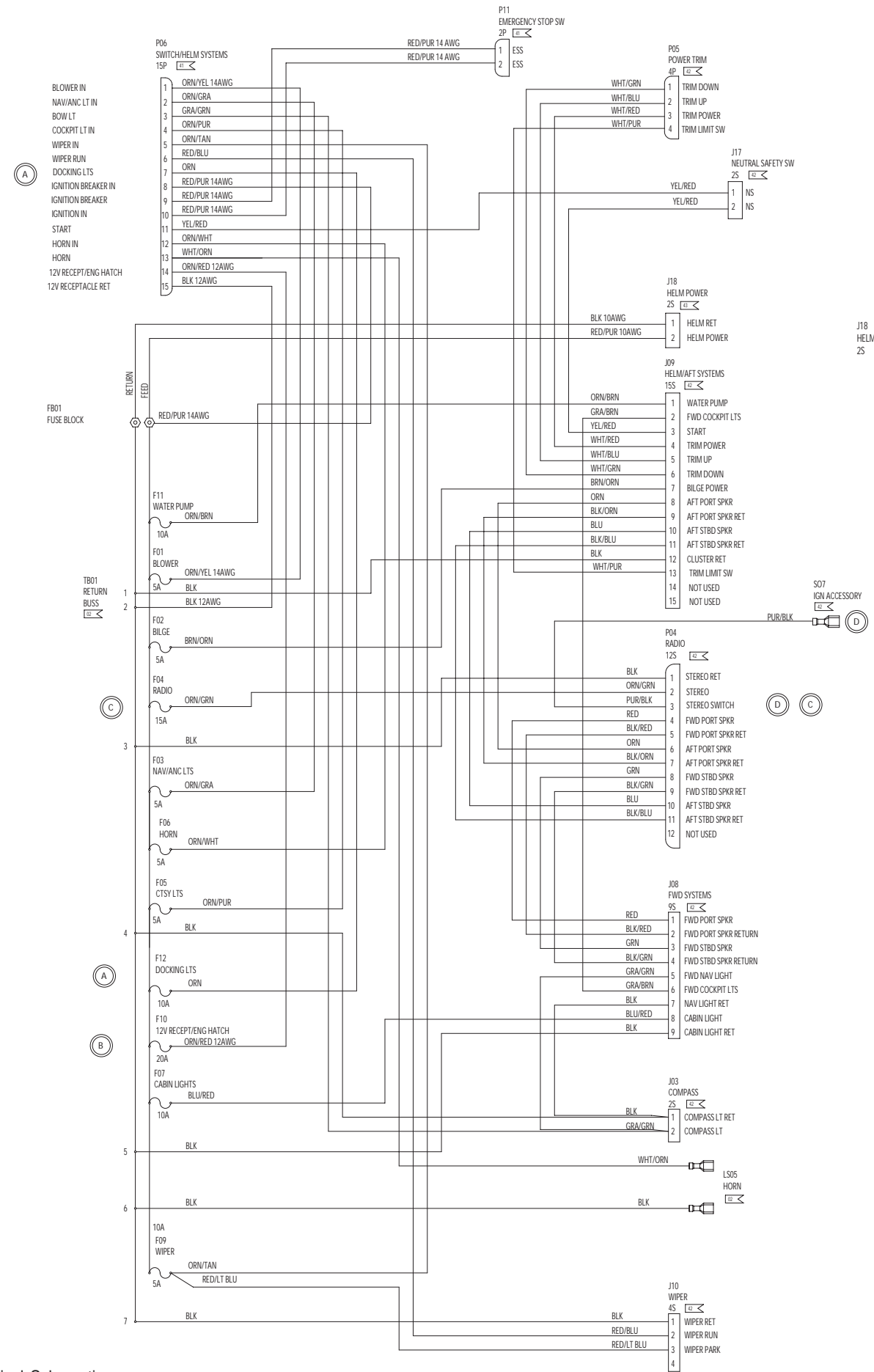

FOUR WINNS PARTS LIST

ITEM	PART NUMBER	QUANTITY	DESCRIPTION	FUNCTION	MANUFACTURER
-	028-0177	22	TERM,FASTON ,250,18-14	02	AMP
-	028-0191	1	TERM,RING,#10,16-14	09	AMP
-	028-0195	2	TERM,RING,#10,12-10	13	AMP
-	028-0390	17	PIN,UMNL,18-14	41	AMP
-	028-0454	43	SOCKET,UMNL,18-14	42	AMP
-	028-0455	2	SOCKET,UMNL,12-10	43	AMP
FB01	028-0505	1	FUSE BLOCK,14 POSITON	HELM FUSE BLOCK	GENERAL
F01	028-0507	1	FUSE,ATC,5A	BLOWER	BUSS
F02	028-0507	1	FUSE,ATC,5A	BILGE	BUSS
F03	028-0507	1	FUSE,ATC,5A	NAV/ANC LITS	BUSS
F04	028-0510	1	FUSE,ATC,15A	RADIO	BUSS
F05	028-0507	1	FUSE,ATC,5A	COCKPIT LITS	BUSS
F06	028-0507	1	FUSE,ATC,5A	HORN	BUSS
F07	028-0509	1	FUSE,ATC,10A	CABIN LITS	BUSS
F09	028-0507	1	FUSE,ATC,5A	WIPER	BUSS
F10	028-0511	1	FUSE,ATC,20A	12V RECEPTACLE/ENG HATCH	BUSS
F11	028-0509	1	FUSE,ATC,10A	FRESH WATER PUMP	BUSS
F12	028-0509	1	FUSE,ATC,10A	DOCKING LTS	AMP
J03	028-0441	1	RECEPT,UMNL,2 CKT	COMPASS	AMP
J08	028-0443	1	RECEPT,UMNL,9 CKT	FWD SYSTEMS	AMP
J09	028-0445	1	RECEPT,UMNL,12 CKT	HELM/AFT SYSTEMS	AMP
J10	028-0442	1	RECEPT,UMNL,4 CKT	WIPER	AMP
J18	028-0441	1	RECEPT,UMNL,2 CKT	HELM POWER	AMP
LS05	-	REF	HORN,HIDDEN AFI	HORN	-
P04	028-0451	1	PLUG,UMNL,12 CKT	RADIO	AMP
P05	028-0448	1	PLUG,UMNL,4 CKT	POWER TRIM	AMP
P06	028-0452	1	PLUG,UMNL,15 CKT	SWITCH/HELM SYSTEMS	AMP
P11	028-0441	1	RECEPT,UMNL,2 CKT	NEUTRAL SAFETY	AMP
P17	028-0447	1	PLUG,UMNL,2 CKT	ESS	AMP
TB01	-	REF	DC RET BUSS	RETURN BUSS	-

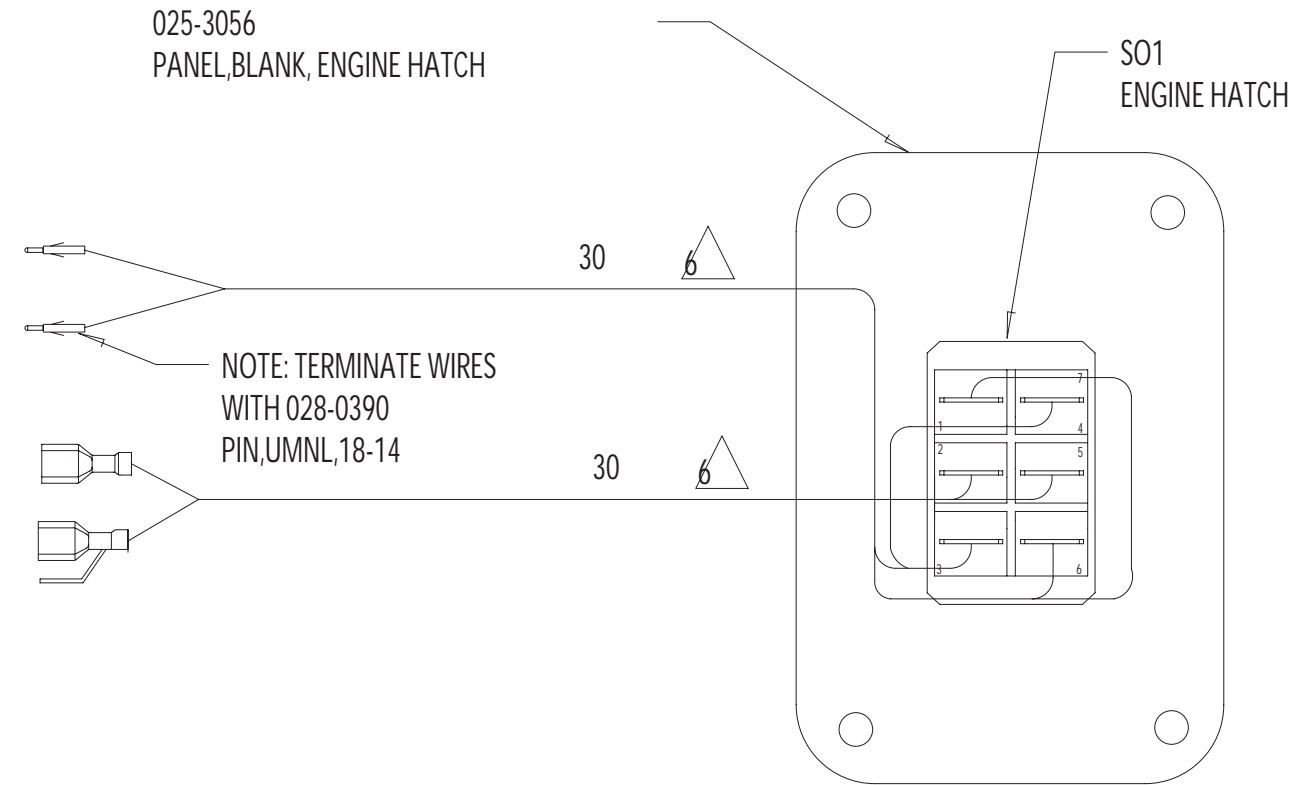
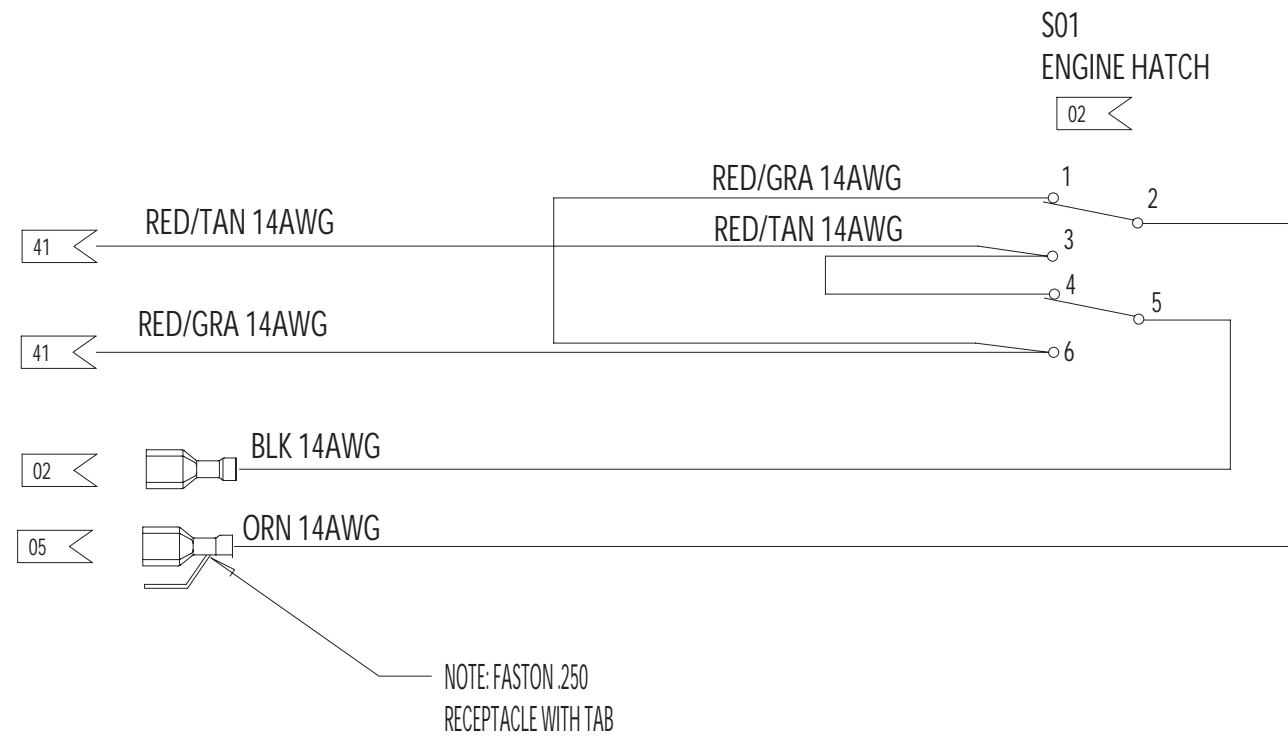

FOUR WINNS PARTS LIST

ITEM	PART NUMBER	QUANTITY	DESCRIPTION	FUNCTION	MANUFACTURER
-	028-0177	6	RECEPT,FASTON,.250,18-14	02	AMP
-	028-0219	1	RECEPT,FASTON, W/TAB.250,18-14	05	AMP
-	028-0390	2	PIN,UMNL,18-14	41	AMP
-	025-3056	1	PANEL,BLANK,ENGINE HATCH	-	
S01	028-0460	1	SWITCH,DPDT,CONT III,(ON)OFF(O)	ENGINE HATCH	CARLINGSWITCH

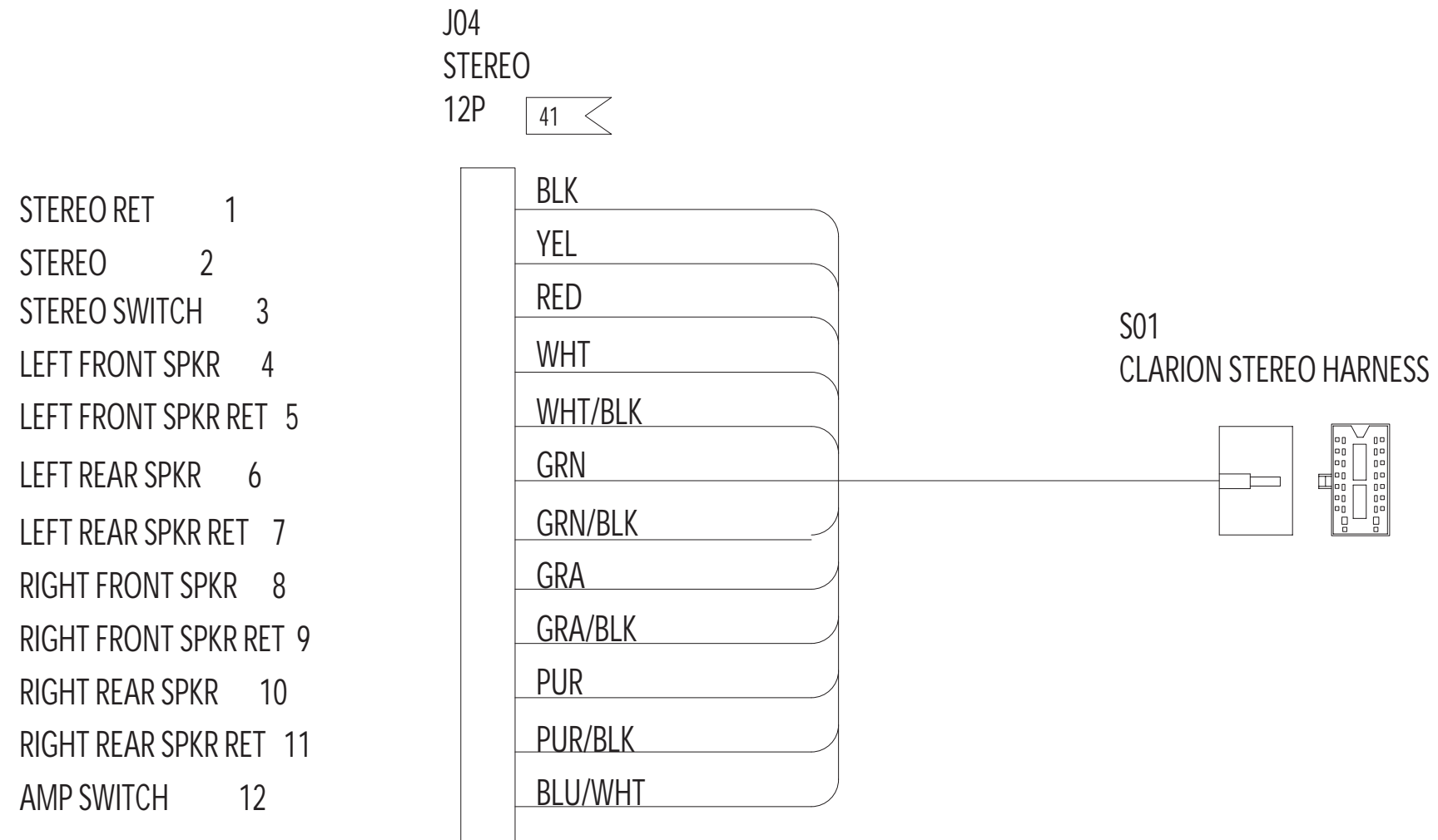

FOUR WINNS PARTS LIST

ITEM	PART NUMBER	QUANTITY	DESCRIPTION	FUNCTION	MANUFACTURER
	028-0390	3	PIN,UMNL,18-14	41	AMP
	028-1036	8	PIN,UMNL,24-18	57	AMP
J04	028-0445	1	RECEPT,UMNL,12 CKT	STEREO ADAPTOR	AMP
S01	027-2441	1	CLARION STEREO PLUG ASSY	CLARION STEREO	CLARION

CLARION STEREO ADAPTER HARNESS ASSEMBLY

JO4
RADIO
12S

41 <

35'

P04
RADIO
12P

42 <

RADIO RET
RADIO PWR/MEM
RADIO SWITCH
FWD PORT SPKR
FWD PORT SPKR RETURN
AFT PORT SPKR
AFT PORT SPKR RETURN
FWD STBD SPKR
FWD STBD SPKR RETURN
AFT STBD SPKR
AFT STBD SPKR RETURN
AMP SWITCH

1	YEL 14AWG	YEL 14AWG
2	ORN/GRN 14AWG	ORN/GRN 14AWG
3	PUR/BLK 14AWG	PUR/BLK 14AWG
4	RED 14AWG	RED 14AWG
5	BLK/RED 14AWG	BLK/RED 14AWG
6	ORN 14AWG	ORN 14AWG
7	BLK/ORN 14AWG	BLK/ORN 14AWG
8	GRN 14AWG	GRN 14AWG
9	BLK/GRN 14AWG	BLK/GRN 14AWG
10	BLU 14AWG	BLU 14AWG
11	BLK/BLU 14AWG	BLK/BLU 14AWG
12	BLU/WHT	BLU/WHT

RADIO RET
RADIO PWR/MEM
RADIO SWITCH
FWD PORT SPKR
FWD PORT SPKR RETURN
AFT PORT SPKR
AFT PORT SPKR RETURN
FWD STBD SPKR
FWD STBD SPKR RETURN
AFT STBD SPKR
AFT STBD SPKR RETURN
AMP SWITCH

A

A

FOUR WINNS PARTS LIST

ITEM	PART NUMBER	QUANTITY	DESCRIPTION	FUNCTION	MANUFACTURER
-	028-0390	12	PIN,UMNL,18-14	41	AMP
-	028-0454	12	SOCKET,UMNL,18-14	42	AMP
JO4	028-0445	1	RECEPT,UMNL,12 CKT	RADIO EXTENSION	AMP
PO4	028-0451	1	PLUG,UMNL,12 CKT	RADIO	AMP

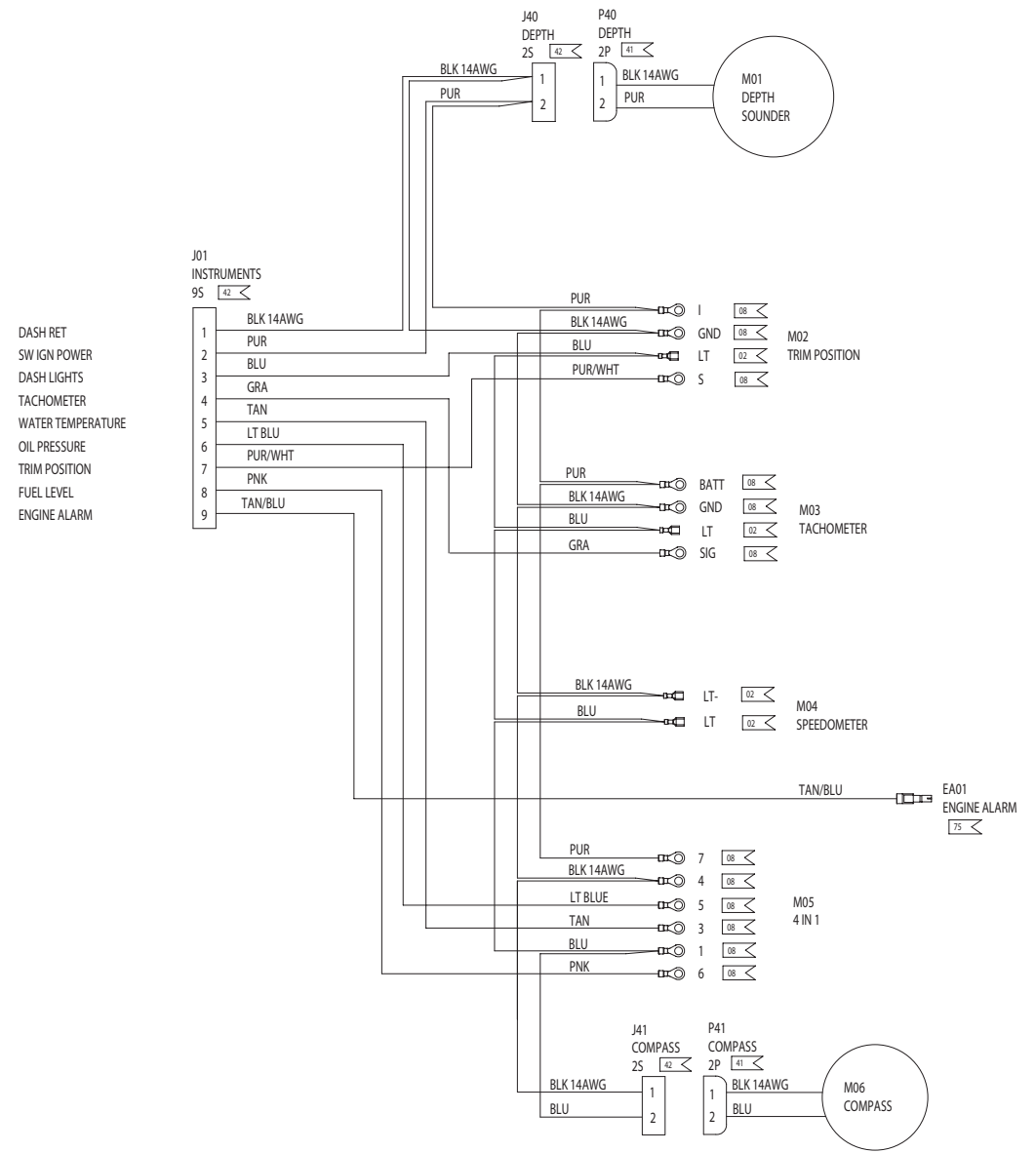
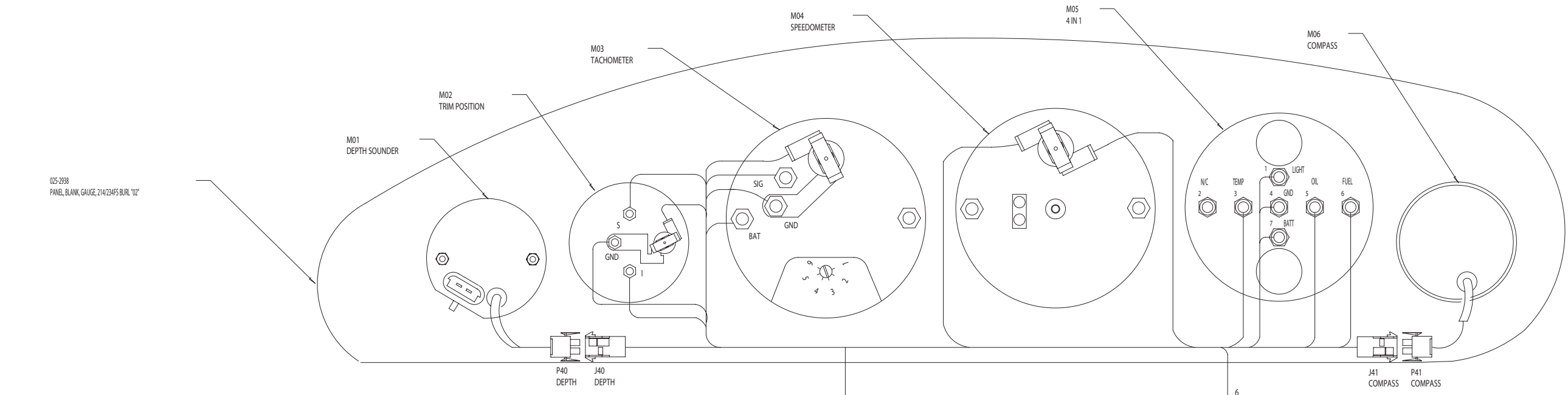

- 1 DASH RET
- 2 SW IGN POWER
- 3 DASH LIGHTS
- 4 TACHOMETER
- 5 WATER TEMPERATURE
- 6 OIL PRESSURE
- 7 TRIM POSITION
- 8 FUEL LEVEL
- 9 ENGINE ALARM

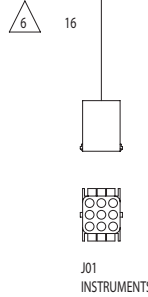

FOUR WINNS PARTS LIST

ITEM	PART NUMBER	QUANTITY	DESCRIPTION	FUNCTION	MANUFACTURER
	028-0177	4	RECEPTACLE,FASTON,.250,16-14	02	AMP
	028-0189	12	TERMINAL,RING,PG,#8, 16-14	08	AMP
	028-0390	4	PIN,UMNL,18-14	41	AMP
	028-0454	13	SOCKET,UMNL,18-14	42	AMP
	028-1822	1	TERM,BULLET,FEMALE,INS,.156,16-14	75	MOLEX
	025-2938	1	PANEL,BLANK,INSTR, BURL	-	-
J01	028-0443	1	RECEPT,UMNL, 9 CKT	INSTRUMENTS	AMP
J40	028-0441	1	RECEPT,UMNL, 2 CKT	DEPTH	AMP
J41	028-0441	1	RECEPT,UMNL, 2 CKT	COMPASS	AMP
P40	028-0447	1	PLUG, UMNL, 2 CKT	DEPTH	AMP
P41	028-0447	1	PLUG, UMNL, 2 CKT	COMPASS	AMP
M01	028-1748	1	DEPTH GAUGE FARIA #DS0109	-	FARIA
M02	024-0529	1	TRIM POSITION FARIA #GP7766	-	FARIA
M03	024-0526	1	TACH 6000 W/HOUR FARIA #TC9395	-	FARIA
M04	024-0523	1	SPEEDOMETER FARIA #SE9972	-	FARIA
M05	024-0524	1	4 IN 1 W/FUEL FARIA #GF0223	-	FARIA
M06	065-1369	1	COMPASS	-	RICHIE
EA01		REF	ENGINE ALARM	-	-

214/234/264 FUNSHIP INSTRUMENT GAUGE PANEL ASSEMBLY

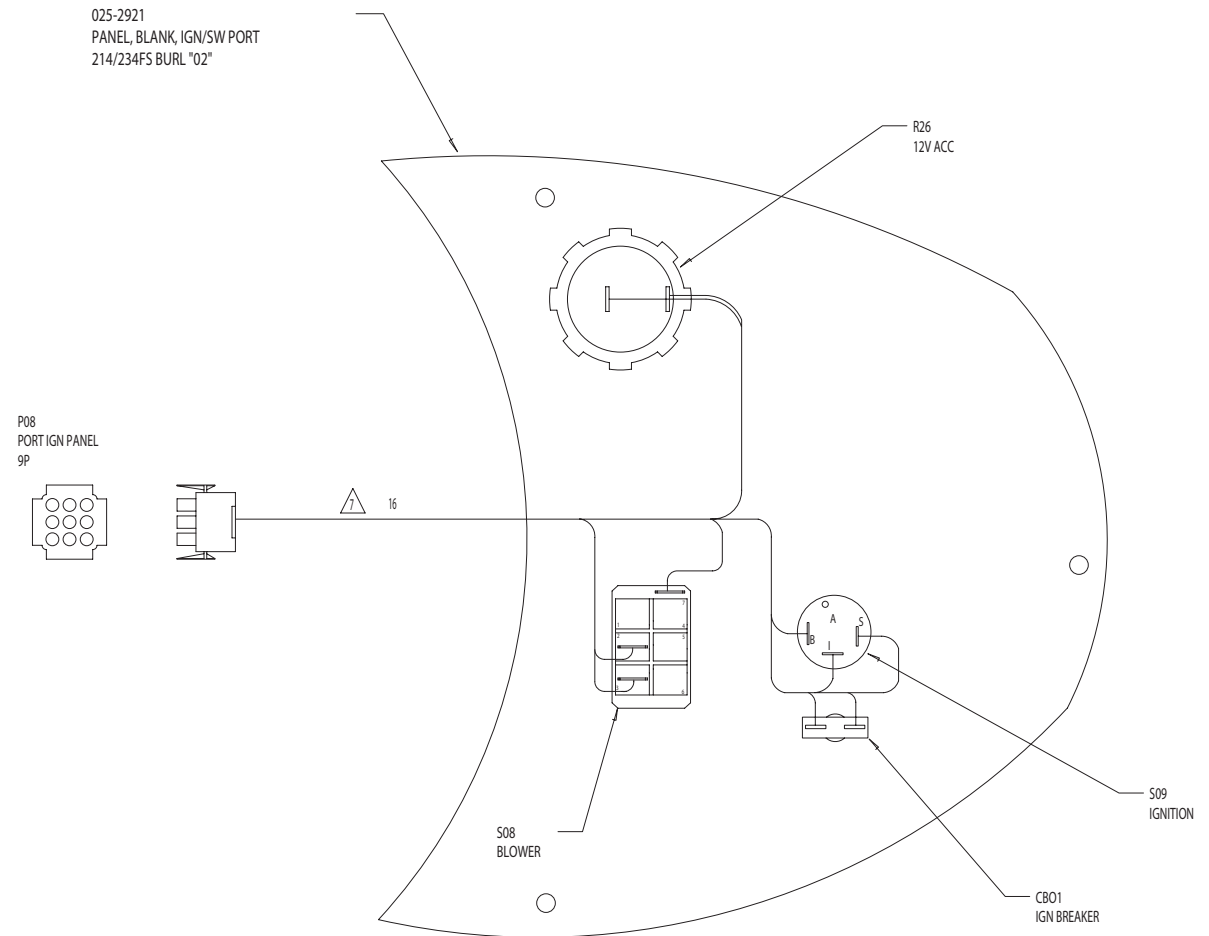
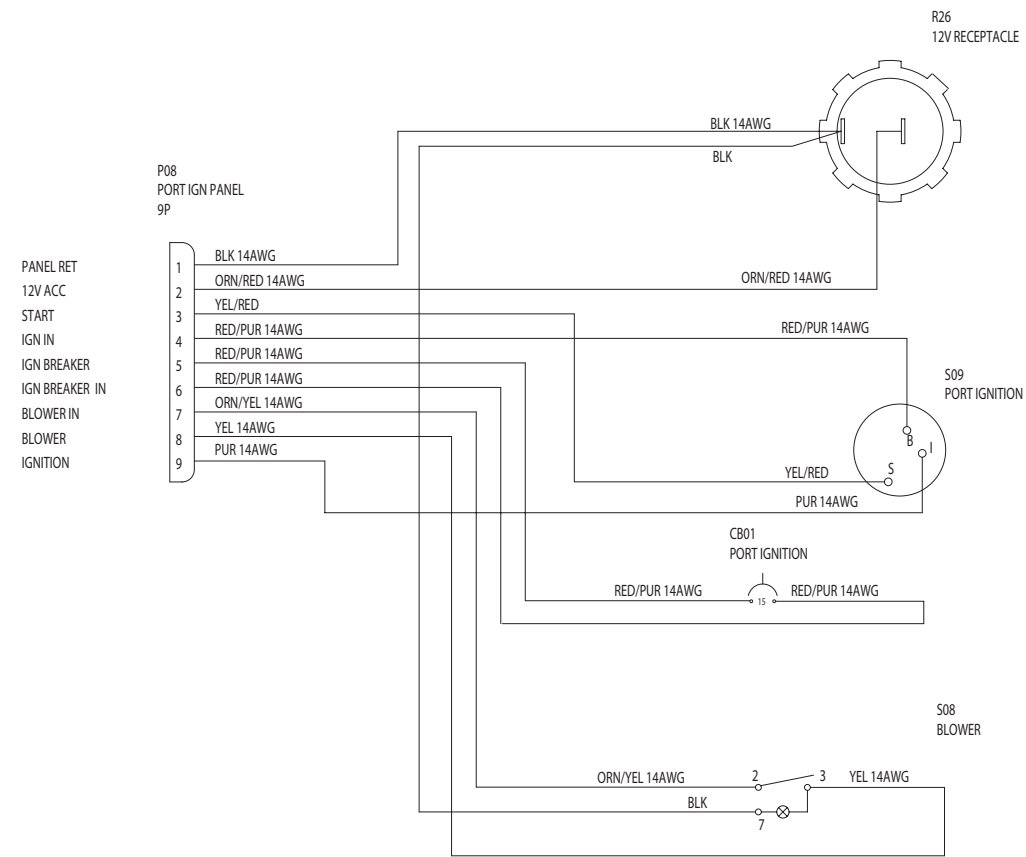

FOUR WINNS PARTS LIST

ITEM	PART NUMBER	QUANTITY	DESCRIPTION	FUNCTION	MANUFACTURER
	028-0177	10	TERM,FASTON,.250,18-14	02	AMP
	028-0454	9	PIN,UMNL,18-14	41	AMP
	025-2921	1	PANEL,BLANK,IGNI/SW PORT		
P08	028-0449	1	PLUG,UMNL,9 CKT	PORT IGN PANEL	AMP
R26		1	RECEPT,12V AFI	12V RECEPTACLE	AFI
S08	028-0457	1	SWITCH,SPST,CONT III	BLOWER	CARL SW
CB01	028-0467	1	CKT BREAKER, 15A	IGNITION BREAKER	MP
S09	028-1286	1	SWITCH,IGNITION,I/O	IGNITION SWITCH	GENERAL

FOUR WINNS WIRE LIST

COLOR	GA	FIRST	PIN	TERM	NOTE	SECOND	PIN	TERM	NOTE	FUNCTION
BLK	14	P08	1	41		R26	NEG	02	SA	12V ACC RET
ORN/RED	14	P08	2	41		R26	POS	02		12V ACC
YEL/RED	16	P08	3	41		S10	START	02		START
RED/PUR	14	P08	4	41		S10	BATT	02		IGN POWER
RED/PUR	14	P08	5	41		CB01	LINE	02		IGN BREAKER IN
RED/PUR	14	P08	6	41		CB01	LOAD	02		IGN BREAKER
ORN/YEL	14	P08	7	41		S08	2	02		BLOWER IN
YEL	14	P08	8	41		S08	3	02		BLOWER
PUR	14	P08	9	41		S10	IGN	02		IGNITION
BLK	14	R26	NEG	02	SA	S08	7	02		BLOWER SW LT RET

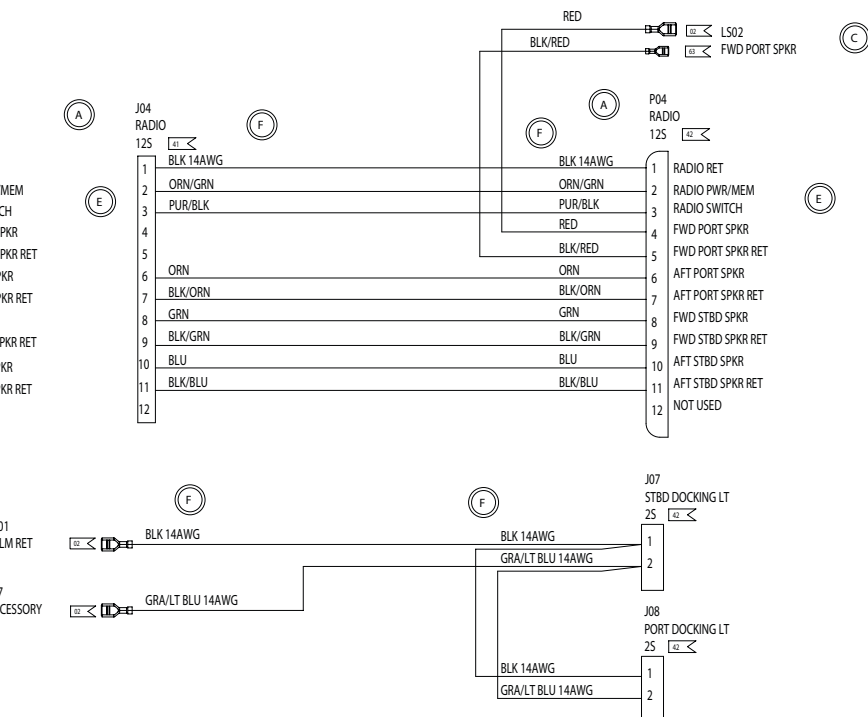
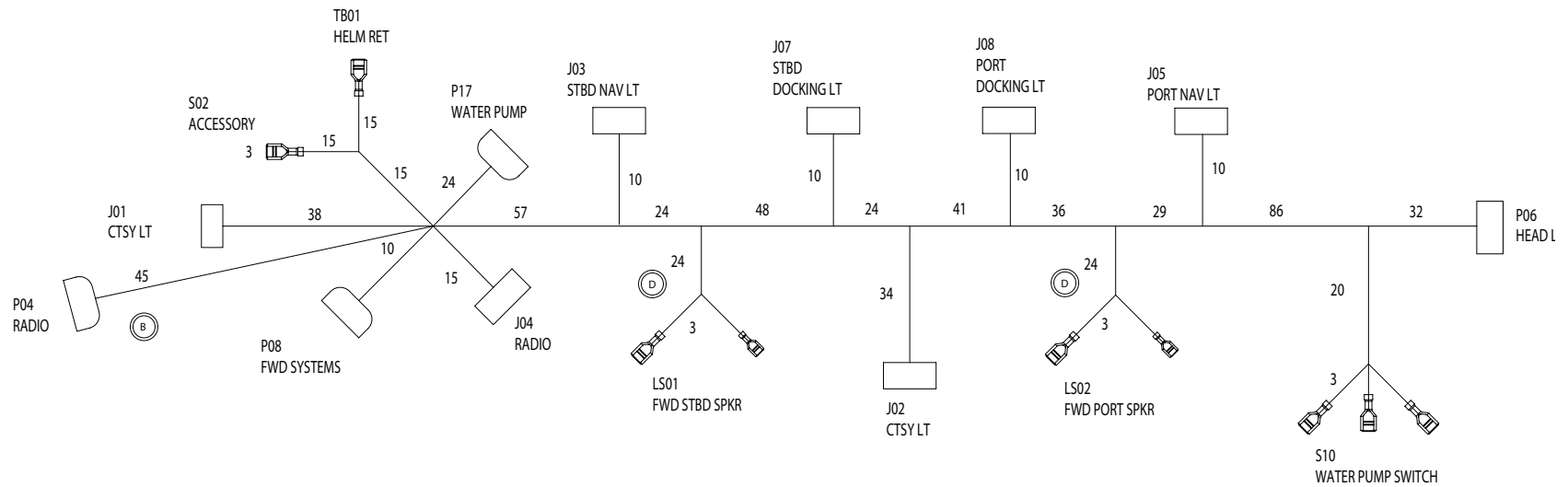
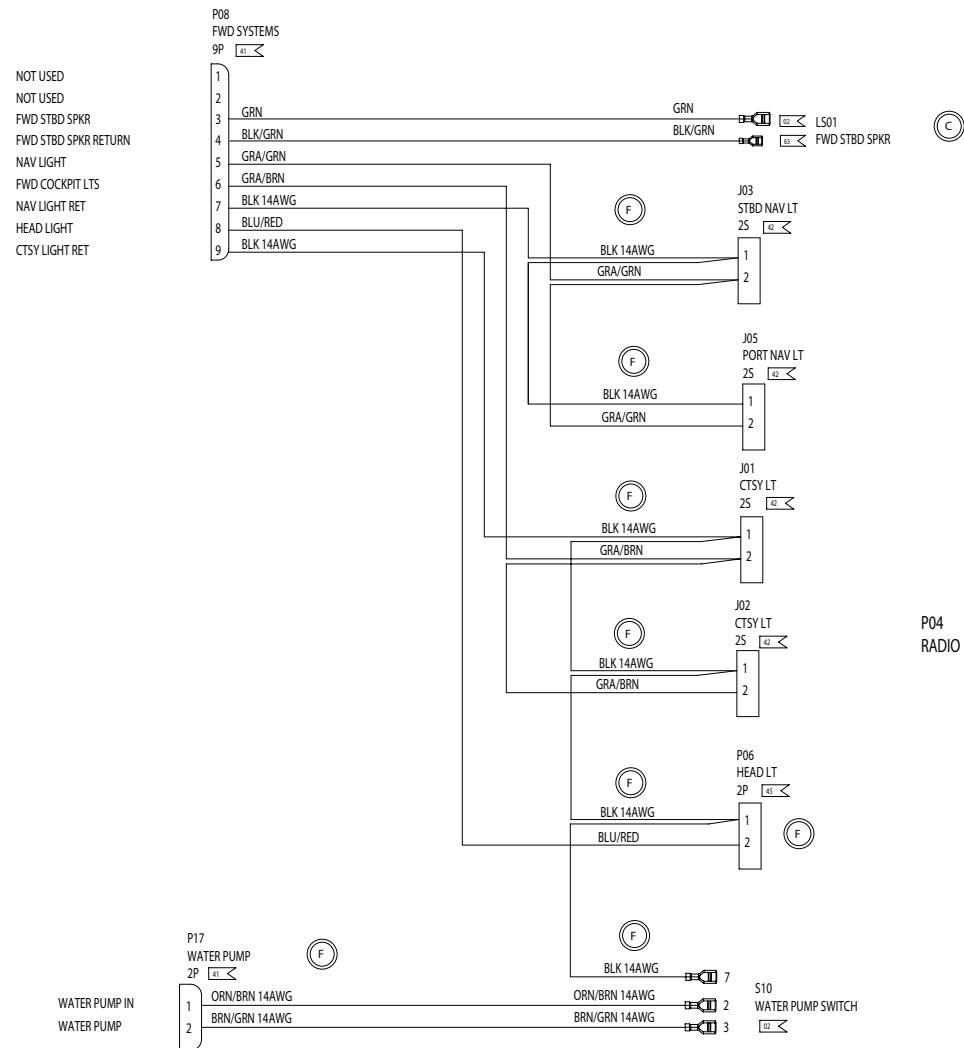

NOTES:

FOUR WINNS PARTS LIST

ITEM	PART NUMBER	QUANTITY	DESCRIPTION	FUNCTION	MANUFACTU
-	028-0177	7	TERM,FASTON,,250,18-14	02	AMP
-	028-0390	18	PIN,UMNL,18-14	41	AMP
-	028-0454	23	SOCKET,UMNL,18-14	42	AMP
-	028-0159	2	SOCKET,CMNL,20-14	45	AMP
-	028-1248	2	TERM,FASTON,,205,18-14	63	AMP
J01	028-0441	1	RECEPT,UMNL,2 CKT	CTS Y LT	AMP
J02	028-0441	1	RECEPT,UMNL,2 CKT	CTS Y LT	AMP
J03	028-0441	1	RECEPT,UMNL,2 CKT	STBD NAV LT	AMP
J04	028-0445	1	RECEPT,UMNL,12 CKT	RADIO	AMP
J05	028-0441	1	RECEPT,UMNL,2 CKT	PORT NAV LT	AMP
J07	028-0441	1	RECEPT,UMNL,2 CKT	STBD DOCKING LT	AMP
J08	028-0441	1	RECEPT,UMNL,2 CKT	PORT DOCKING LT	AMP
P04	028-0451	1	PLUG,UMNL,12,CKT	RADIO	AMP
P06	028-0161	1	HOUSING,SCKT 2CKT	HEAD LT	AMP
LS01	-	REF	SPEAKER	FWD STBD SPKR	-
LS02	-	REF	SPEAKER	FWD PORT SPKR	-
P17	028-0447	1	PLUG,UMNL,2 CKT	WATER PUMP	AMP
P08	028-0449	1	PLUG,UMNL,9 CKT	FWD SYSTEMS	AMP
S02	028-0457	REF	SWITCH,SPST,CONT III	DOCKING LTS SW	-
S10	028-0457	REF	SWITCH,SPST,CONT III	WATER PUMP SW	-
TB01	-	REF	HELM RET	HELM RET	-

214/234/264 FUNSHIP FORWARD SYSTEMS HARNESS ASSEMBLY

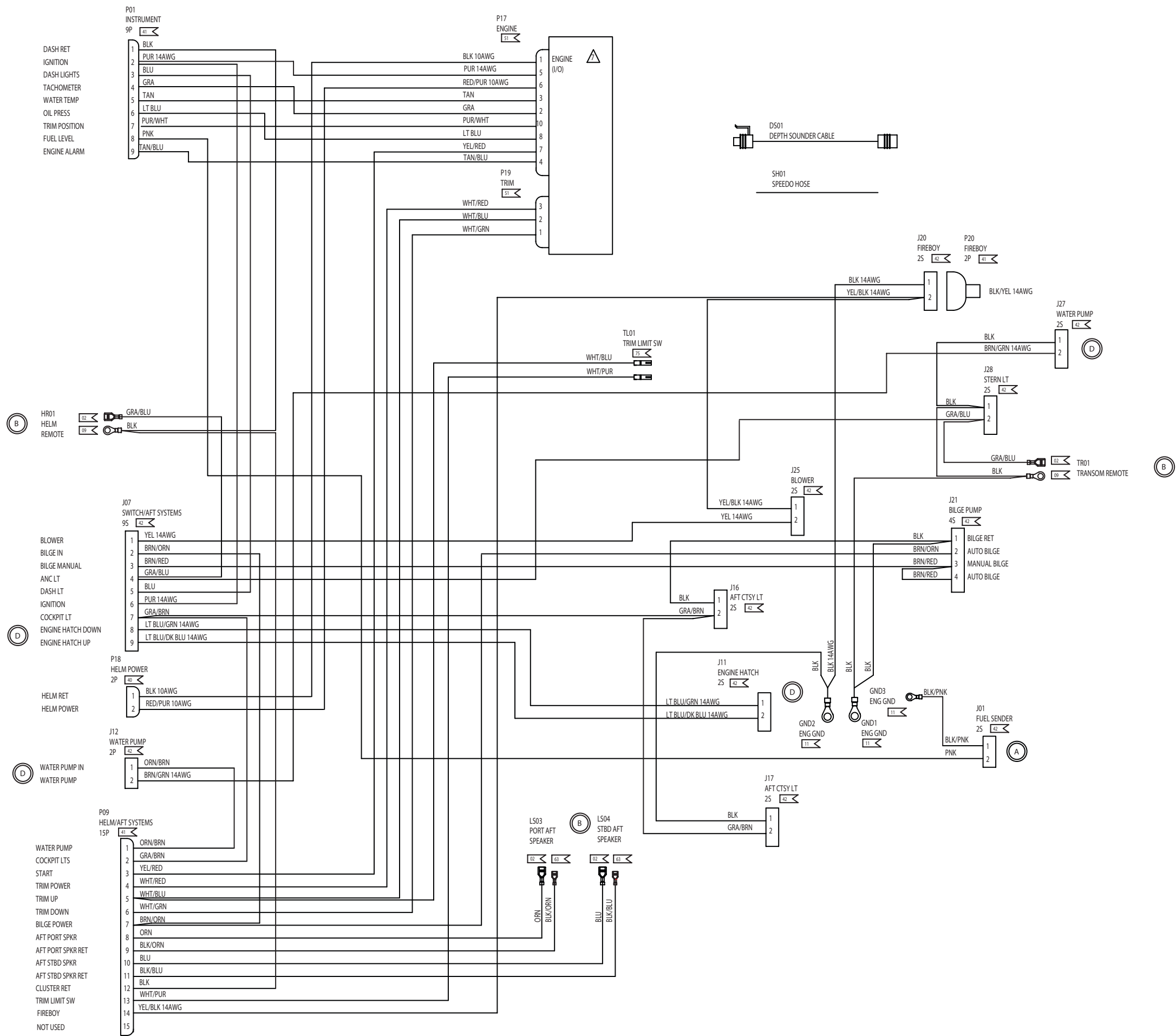

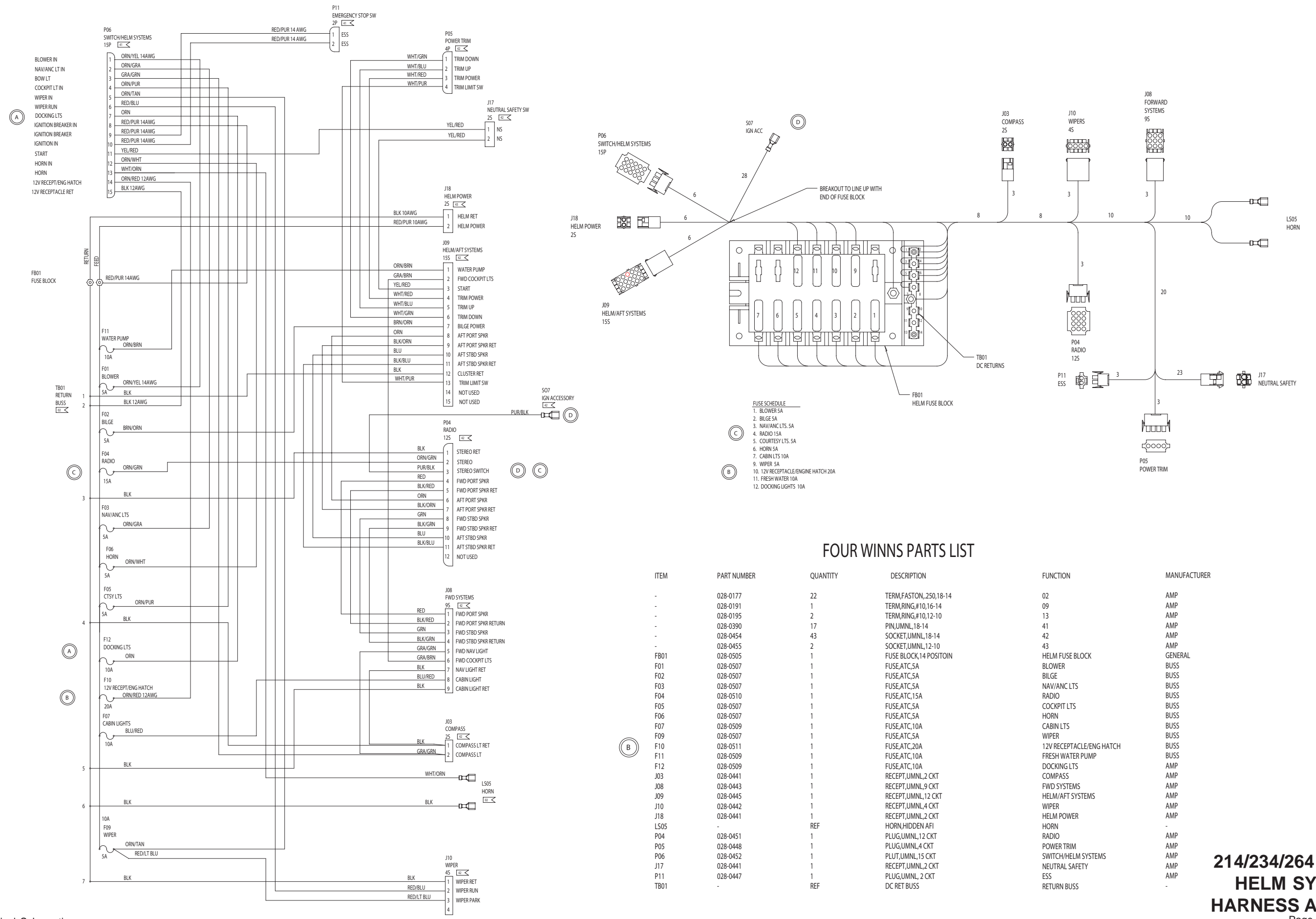

FUSE SCHEDULE

1. BLOWER SA
2. BILGE SA
3. NAV/ANC LTS. SA
4. RADIO 1SA
5. COURTESY LTS. SA
6. HORN SA
7. CABIN LTS 10A
9. WIPER SA
10. 12V RECEPTACLE/ENGINE HATCH 20A
11. FRESH WATER 10A
12. DOCKING LIGHTS 10A

FOUR WINNS PARTS LIST

ITEM	PART NUMBER	QUANTITY	DESCRIPTION	FUNCTION	MANUFACTURER
-	028-0177	22	TERM,FASTON,.250,18-14	02	AMP
-	028-0191	1	TERM,RING,#10,16-14	09	AMP
-	028-0195	2	TERM,RING,#10,12-10	13	AMP
-	028-0390	17	PIN,UMNL,18-14	41	AMP
-	028-0454	43	SOCKET,UMNL,18-14	42	AMP
-	028-0455	2	SOCKET,UMNL,12-10	43	AMP
FB01	028-0505	1	FUSE BLOCK,14 POSITON	HELM FUSE BLOCK	GENERAL
F01	028-0507	1	FUSE,ATC,5A	BLOWER	BUSS
F02	028-0507	1	FUSE,ATC,5A	BILGE	BUSS
F03	028-0507	1	FUSE,ATC,5A	NAV/ANC LTS	BUSS
F04	028-0510	1	FUSE,ATC,15A	RADIO	BUSS
F05	028-0507	1	FUSE,ATC,5A	COCKPIT LTS	BUSS
F06	028-0507	1	FUSE,ATC,5A	HORN	BUSS
F07	028-0509	1	FUSE,ATC,10A	CABIN LTS	BUSS
F09	028-0507	1	FUSE,ATC,5A	WIPER	BUSS
F10	028-0511	1	FUSE,ATC,20A	12V RECEPTACLE/ENG HATCH	BUSS
F11	028-0509	1	FUSE,ATC,10A	FRESH WATER PUMP	BUSS
F12	028-0509	1	FUSE,ATC,10A	DOCKING LTS	AMP
J03	028-0441	1	RECEPT,UMNL,2 CKT	COMPASS	AMP
J08	028-0443	1	RECEPT,UMNL,9 CKT	FWD SYSTEMS	AMP
J09	028-0445	1	RECEPT,UMNL,12 CKT	HELM/AFT SYSTEMS	AMP
J10	028-0442	1	RECEPT,UMNL,4 CKT	WIPER	AMP
J18	028-0441	1	RECEPT,UMNL,2 CKT	HELM POWER	AMP
LS05	-	REF	HORN,HIDDEN AFI	HORN	-
P04	028-0451	1	PLUG,UMNL,12 CKT	RADIO	AMP
P05	028-0448	1	PLUG,UMNL,4 CKT	POWER TRIM	AMP
P06	028-0452	1	PLUT,UMNL,15 CKT	SWITCH/HELM SYSTEMS	AMP
J17	028-0441	1	RECEPT,UMNL,2 CKT	NEUTRAL SAFETY	AMP
P11	028-0447	1	PLUG,UMNL,2 CKT	ESS	AMP
TB01	-	REF	DC RET BUSS	RETURN BUSS	-

**214/234/264 FUNSHIP
HELM SYSTEMS
HARNESS ASSEMBLY**

FOUR WINNS PARTS LIST

ITEM	PART NUMBER	QUANTITY	DESCRIPTION	FUNCTION	MANUFACTURER
	028-0390	3	PIN,UMNL,18-14	41	AMP
	028-1036	8	PIN,UMNL,24-18	57	AMP
J04	028-0448	1	RECEPT,UMNL,12 CKT	STEREO ADAPTOR	AMP
S01	027-1823	1	SONY STEREO HARNESS	SONY STEREO	SONY

J04
STEREO
12P

- STEREO RET 1
- STEREO 2
- STEREO MEMORY 3
- LEFT FRONT SPKR 4
- LEFT FRONT SPKR RET 5
- LEFT REAR SPKR 6
- LEFT REAR SPKR RET 7
- RIGHT FRONT SPKR 8
- RIGHT FRONT SPKR RET 9
- RIGHT REAR SPKR 10
- RIGHT REAR SPKR RET 11
- NOT USED 12

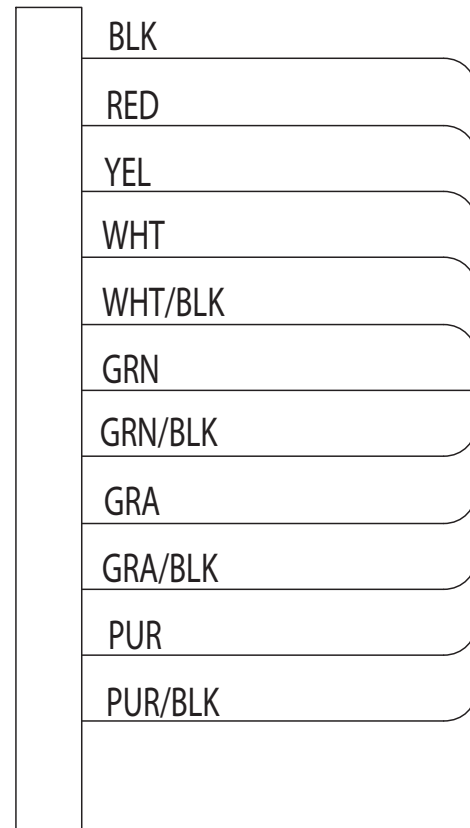

S01
SONY STEREO HARNESS

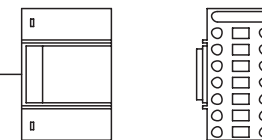

FOUR WINNS WIRE LIST

COLOR	GA	FIRST	PIN	TERM	NOTE	SECOND	PIN	TERM	NOTE	FUNCTION
BLK	16	KW1		51		J04	1	41		STEREO RET
RED	16	KW1		51		J04	2	41		STEREO
YEL	16	KW1		51		J04	3	41		STEREO MEMORY
WHT	20	KW1		51		J04	4	57		LEFT FRONT SPKR
WHT/BLK	20	KW1		51		J04	5	57		LEFT FRONT SPKR RET
GRN	20	KW1		51		J04	6	57		LEFT REAR SPKR
GRN/BLK	20	KW1		51		J04	7	57		LEFT REAR SPKR RET
GRA	20	KW1		51		J04	8	57		RIGHT FRONT SPKR
GRA/BLK	20	KW1		51		J04	9	57		RIGHT FRONT SPKR RET
PUR	20	KW1		51		J04	10	57		RIGHT REAR SPKR
PUR/BLK	20	KW1		51		J04	11	57		RIGHT REAR SPKR RET

SONY STEREO W/AMP HARNESS ASSEMBLY

Funship™

025-2938
PANEL, BLANK, GAUGE, 214/234FS BURL "02"

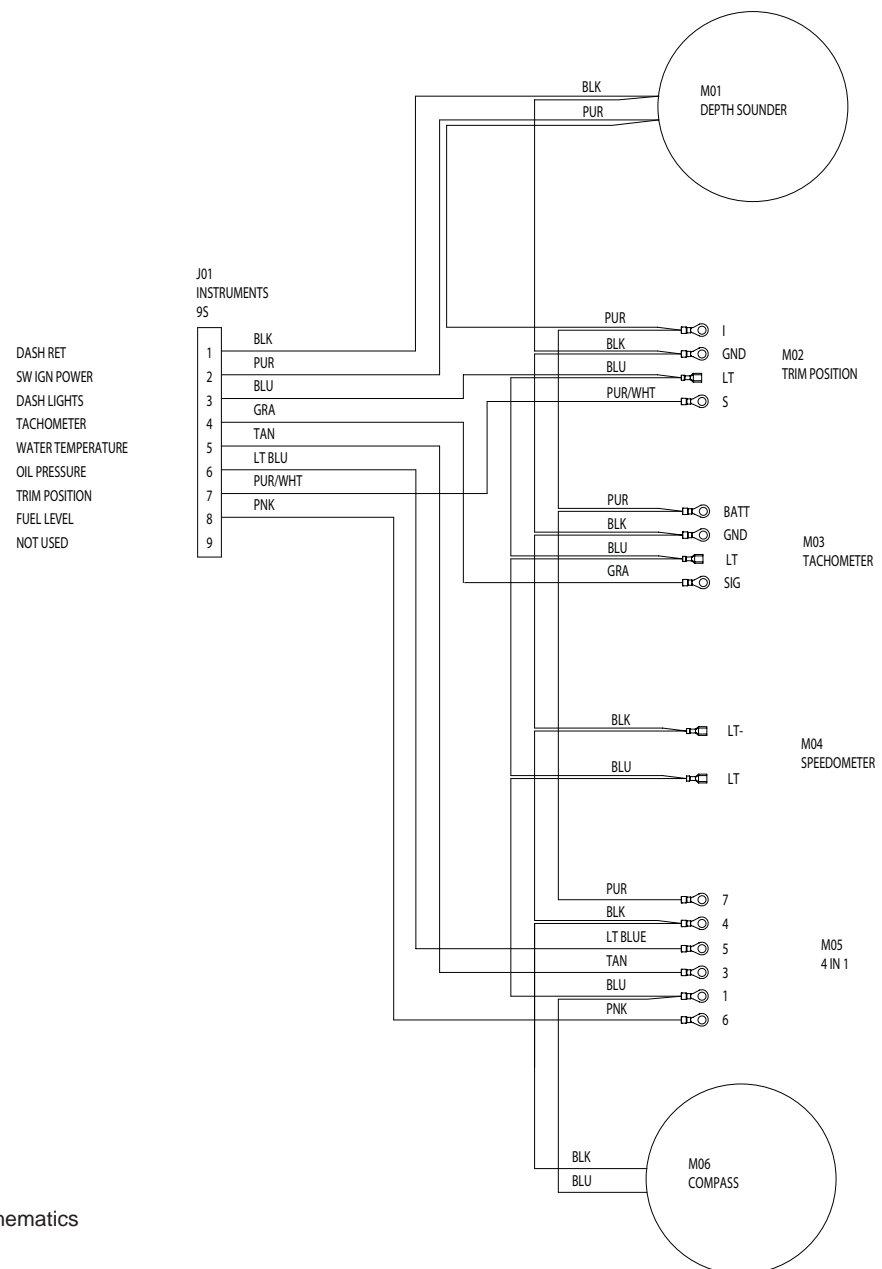
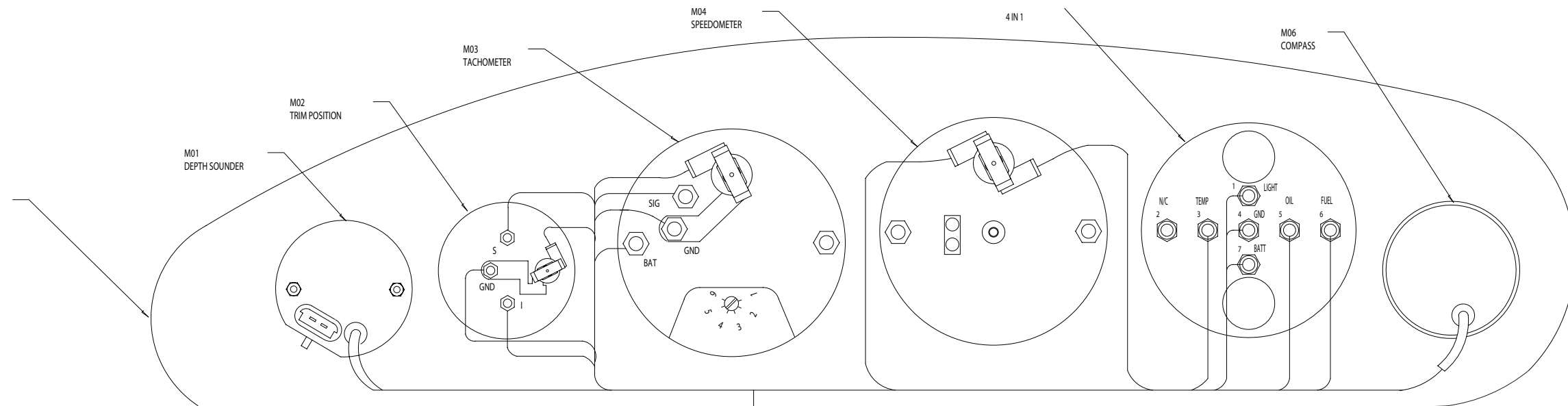

FOUR WINNS PARTS LIST

ITEM	PART NUMBER	QUANTITY	DESCRIPTION	FUNCTION	MANUFACTURER
	028-0177	4	RECEPTACLE,FASTON,.250,16-14	02	AMP
	028-0189	13	TERMINAL,RING,PG,#8, 16-14	08	AMP
	028-0390	2	PIN,UMNL,18-14	41	AMP
	028-0454	10	SOCKET,UMNL,18-14	42	AMP
	025-2938	1	PANEL,BLANK,INSTR, BURL	-	-
J01	028-0443	1	RECEPT,UMNL, 9 CKT	INSTRUMENTS	AMP
J02	028-0441	1	RECEPT,UMNL, 2 CKT	DEPTH	AMP
P02	028-0447	1	PLUG, UMNL, 2 CKT	DEPTH	AMP
M01	028-1748	1	DEPTH GAUGE #DS0012	-	FARIA
M02	024-0508	1	TRIM POSITION GAUGE #GP7590	-	FARIA
M03	024-0505	1	TACHOMETER #TC9395	-	FARIA
M04	024-0501	1	SPEEDOMETER #5E9390	-	FARIA
M05	024-0503	1	4 IN 1 W/FUEL #GF0096	-	FARIA
M06	065-1369	1	COMPASS	-	RICHE

FOUR WINNS WIRE LIST

COLOR	GA	FIRST	PIN	TERM	NOTE	SECOND	PIN	TERM	NOTE	FUNCTION
PUR	16	J01	2	42	-	M01	PWR	51	SA	DEPTH POWER
PUR	16	M01	PUR	51	SA	M02	1	08	SB	TRIM GAUGE POWER
PUR	16	M02	1	08	SB	M03	BAT	08	SC	TACH POWER
PUR	16	M03	BAT	08	SC	M05	7	08	-	4 IN 1 POWER
BLK	16	J01	1	42	-	M01	GND	08	SG	DEPTH GND
BLK	16	M01	GND	08	SG	M02	GND	08	SH	TRIM GND
BLK	16	M02	GND	08	SH	M03	GND	08	SI	TACHOMETER GND
BLK	16	M03	GND	08	SI	M04	LT-	02	SJ	SPEEDO LT GND
BLK	16	M04	LT-	02	SJ	M05	4	08	SK	4 IN 1 GND
BLK	16	M05	4	08	SK	M06	LT-	51	-	COMPASS LT GND
BLU	16	J01	3	42	-	M02	LT	02	SL	TRIM GAUGE LT
BLU	16	M02	LT	02	SL	M03	LT	02	SM	TACHOMETER LT
BLU	16	M03	LT	02	SM	M04	LT	02	SN	SPEEDO LT
BLU	16	M04	LT	02	SN	M05	1	08	SO	4 IN 1 LT
BLU	16	M05	1	08	SO	M06	LT+	51	-	COMPASS LT
GRA	16	J01	4	42	-	M03	SIG	08	-	TACH SIGNAL
TAN	16	J01	5	42	-	M05	3	08	-	WATER TEMP SIGNAL
LT BLU	16	J01	6	42	-	M05	5	08	-	OIL PRESS SIGNAL
PUR/WHT	16	J01	7	42	-	M02	5	08	-	TRIM GA SIGNAL
PNK	16	J01	8	42	-	M05	6	08	-	FUEL GA SIGNAL

214/234/264 FUNSHIP
INSTRUMENT GAUGE
PANEL ASSEMBLY

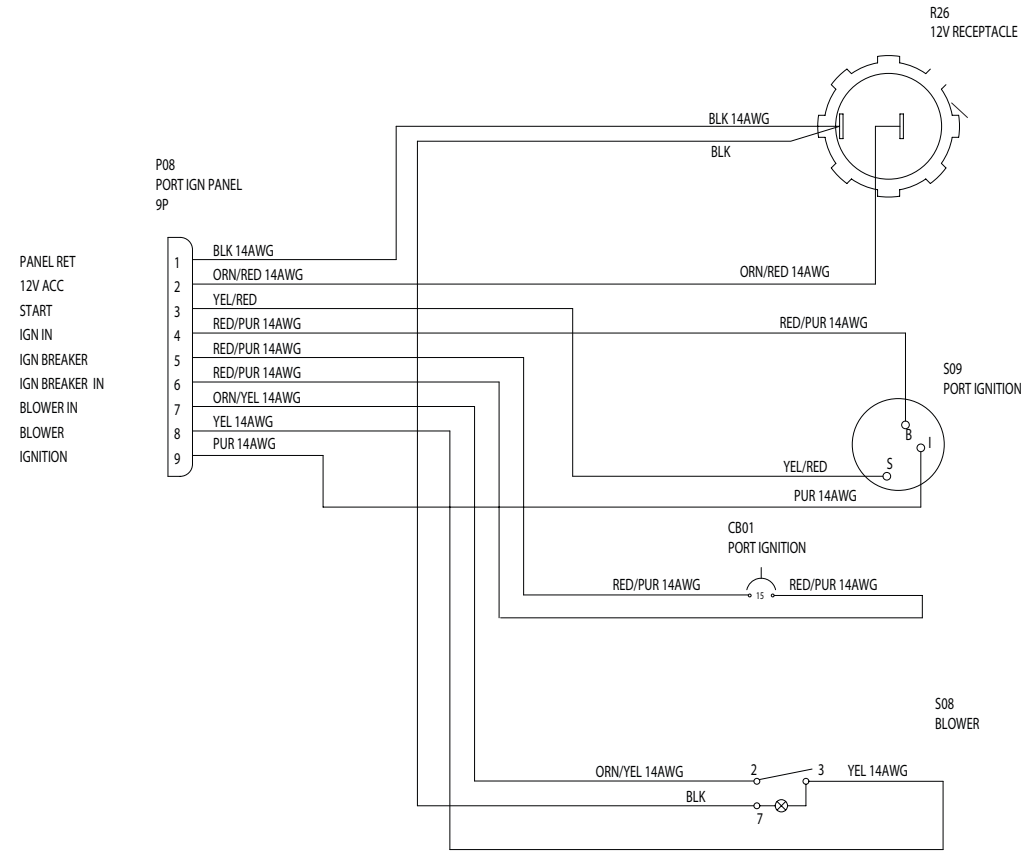

025-2921
PANEL, BLANK, IGN/SW PORT
214/234FS BURL "02"

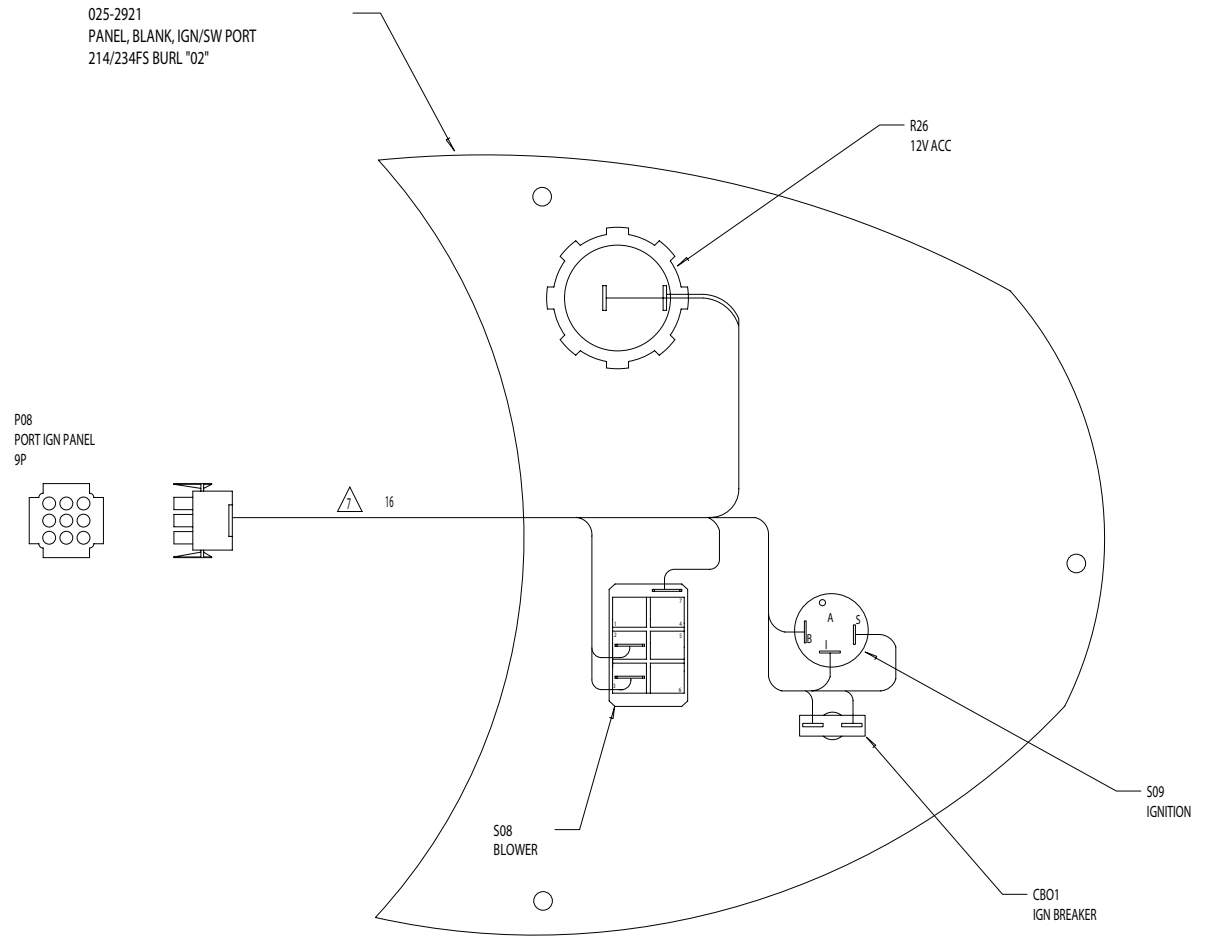

FOUR WINNS PARTS LIST

ITEM	PART NUMBER	QUANTITY	DESCRIPTION	FUNCTION	MANUFACTURER
	028-0177	10	TERM.FASTON_250,18-14	02	AMP
	028-0454	9	PIN,UMNL,18-14	41	AMP
	025-2921	1	PANEL,BLANK,IGN/SW PORT		
P08	028-0449	1	PLUG,UMNL,9 CKT	PORT IGN PANEL	AMP
R26		1	RECEPT,12V AFI	12V RECEPTACLE	AFI
S08	028-0457	1	SWITCH,SPST,CONT III	BLOWER	CARL SW
CB01	028-0467	1	CKT BREAKER, 15A	IGNITION BREAKER	MP
S09	028-1286	1	SWITCH, IGNITION, I/O	IGNITION SWITCH	GENERAL

FOUR WINNS WIRE LIST

COLOR	GA	FIRST	PIN	TERM	NOTE	SECOND	PIN	TERM	NOTE	FUNCTION
BLK	14	P08	1	41		R26	NEG	02	SA	12V ACC RET
ORN/RED	14	P08	2	41		R26	POS	02		12V ACC
YEL/RED	16	P08	3	41		S10	START	02		START
RED/PUR	14	P08	4	41		S10	BATT	02		IGN POWER
RED/PUR	14	P08	5	41		CB01	LINE	02		IGN BREAKER IN
RED/PUR	14	P08	6	41		CB01	LOAD	02		IGN BREAKER
ORN/YEL	14	P08	7	41		S08	2	02		BLOWER IN
YEL	14	P08	8	41		S08	3	02		BLOWER
PUR	14	P08	9	41		S10	IGN	02		IGNITION
BLK	14	R26	NEG	02	SA	S08	7	02		BLOWER SW LT RET

214/234/264 FUNSHIP
PORT IGNITION/SWITCH
PANEL ASSEMBLY

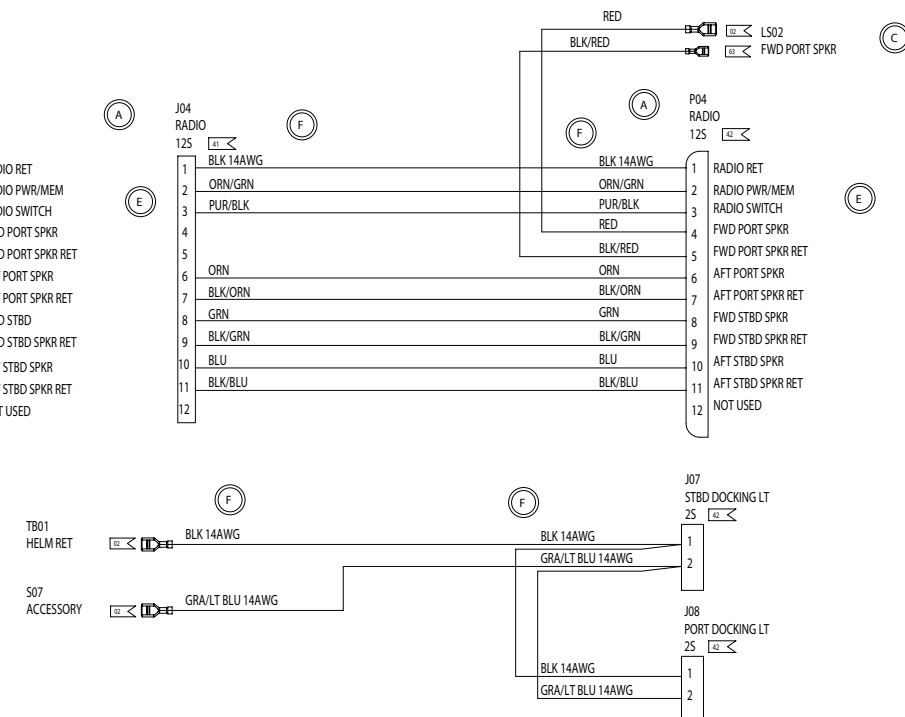
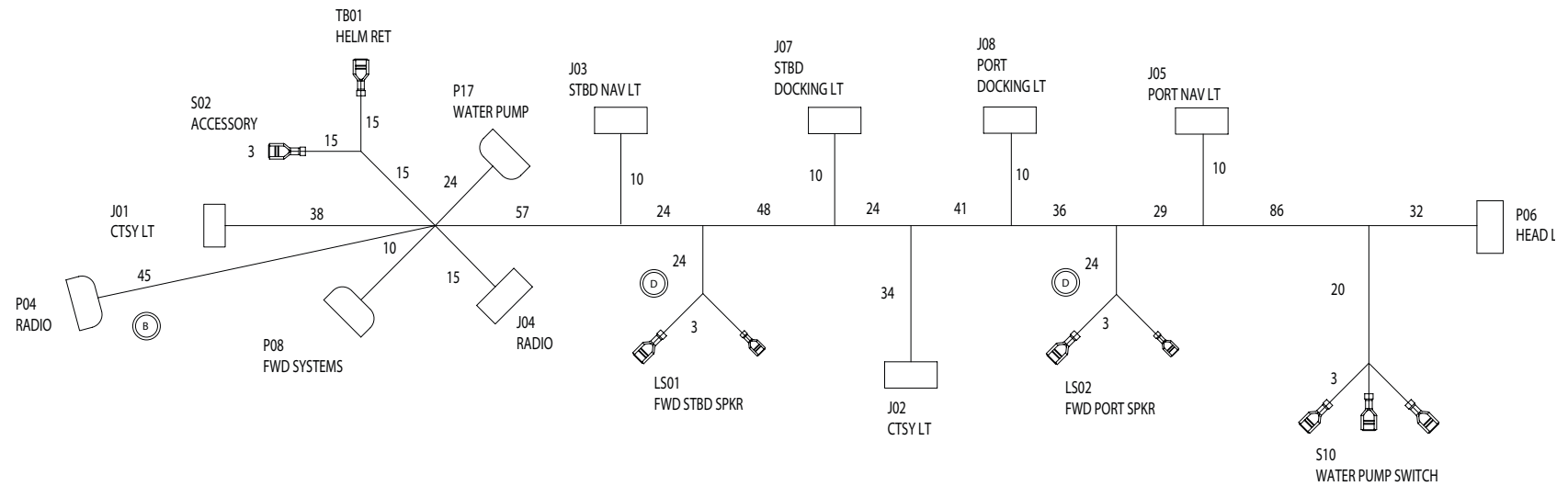
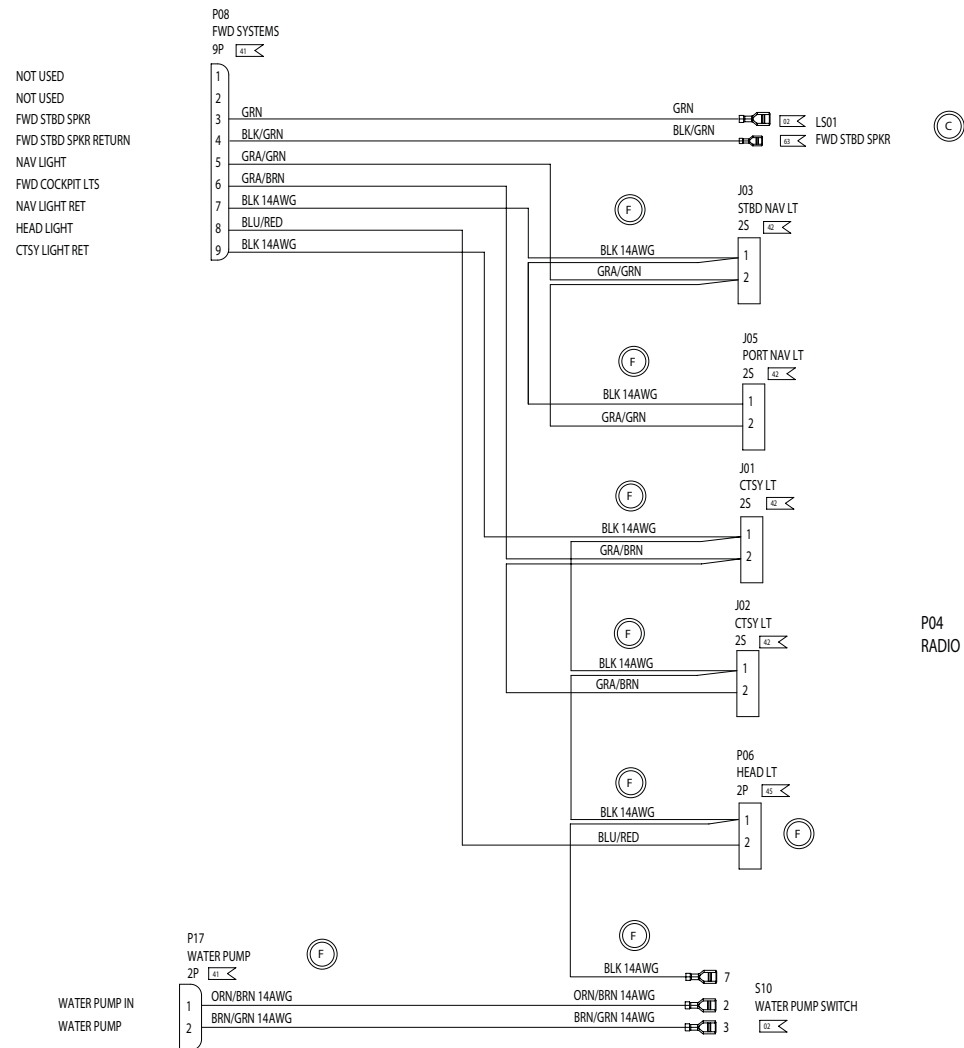

NOTES:

FOUR WINNS PARTS LIST

ITEM	PART NUMBER	QUANTITY	DESCRIPTION	FUNCTION	MANUFACTU
-	028-0177	7	TERM,FASTON,,250,18-14	02	AMP
-	028-0390	18	PIN,UMNL,18-14	41	AMP
-	028-0454	23	SOCKET,UMNL,18-14	42	AMP
-	028-0159	2	SOCKET,CMNL,20-14	45	AMP
-	028-1248	2	TERM,FASTON,,205,18-14	63	AMP
J01	028-0441	1	RECEPT,UMNL,2 CKT	CTS Y LT	AMP
J02	028-0441	1	RECEPT,UMNL,2 CKT	CTS Y LT	AMP
J03	028-0441	1	RECEPT,UMNL,2 CKT	STBD NAV LT	AMP
J04	028-0445	1	RECEPT,UMNL,12 CKT	RADIO	AMP
J05	028-0441	1	RECEPT,UMNL,2 CKT	PORT NAV LT	AMP
J07	028-0441	1	RECEPT,UMNL,2 CKT	STBD DOCKING LT	AMP
J08	028-0441	1	RECEPT,UMNL,2 CKT	PORT DOCKING LT	AMP
P04	028-0451	1	PLUG,UMNL,12,CKT	RADIO	AMP
P06	028-0161	1	HOUSING,SCKT 2CKT	HEAD LT	AMP
LS01	-	REF	SPEAKER	FWD STBD SPKR	-
LS02	-	REF	SPEAKER	FWD PORT SPKR	-
P17	028-0447	1	PLUG,UMNL,2 CKT	WATER PUMP	AMP
P08	028-0449	1	PLUG,UMNL,9 CKT	FWD SYSTEMS	AMP
S02	028-0457	REF	SWITCH,SPST,CONT III	DOCKING LTS SW	-
S10	028-0457	REF	SWITCH,SPST,CONT III	WATER PUMP SW	-
TB01	-	REF	HELM RET	HELM RET	-

214/234/264 FUNSHIP FORWARD SYSTEMS HARNESS ASSEMBLY

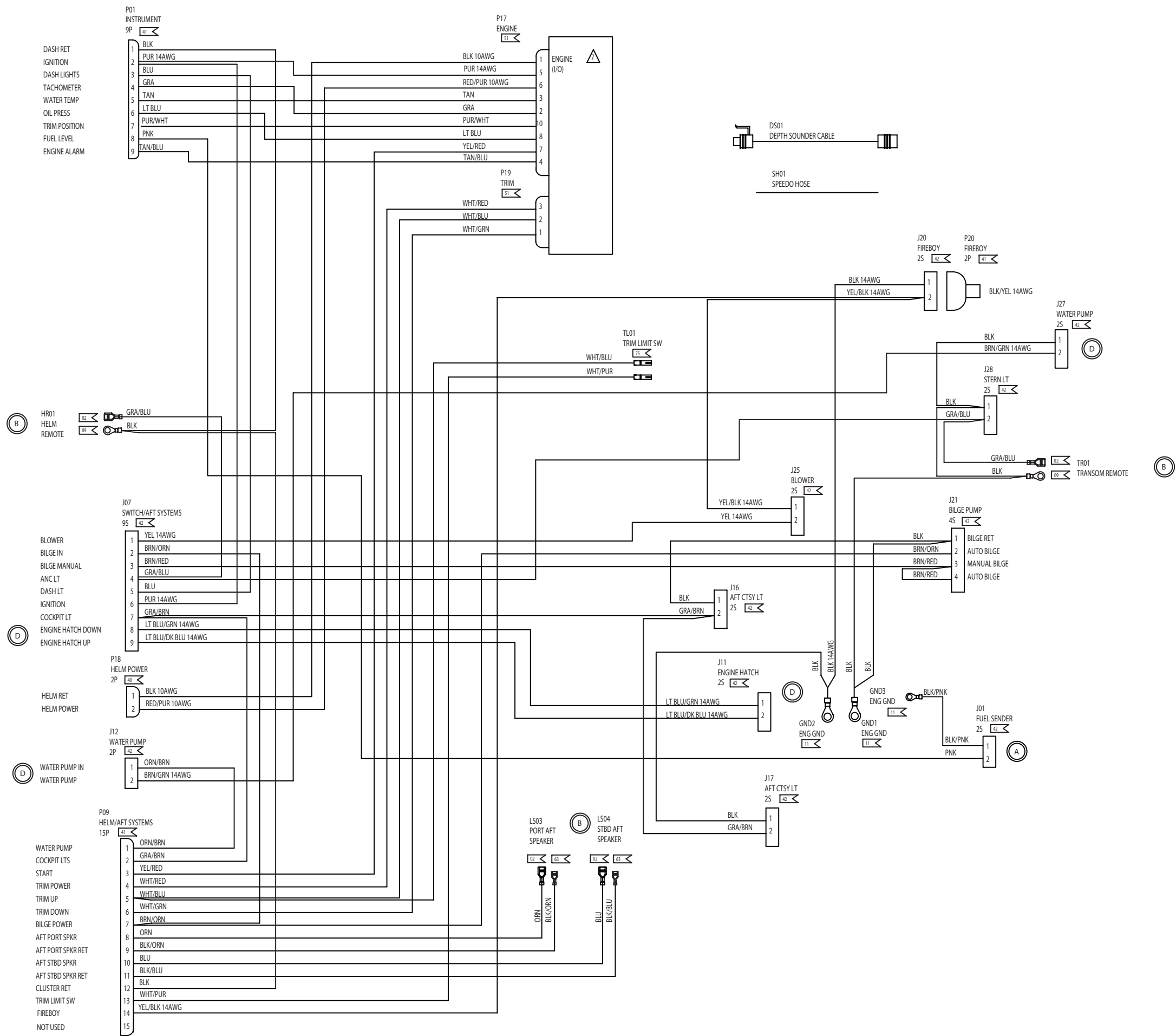

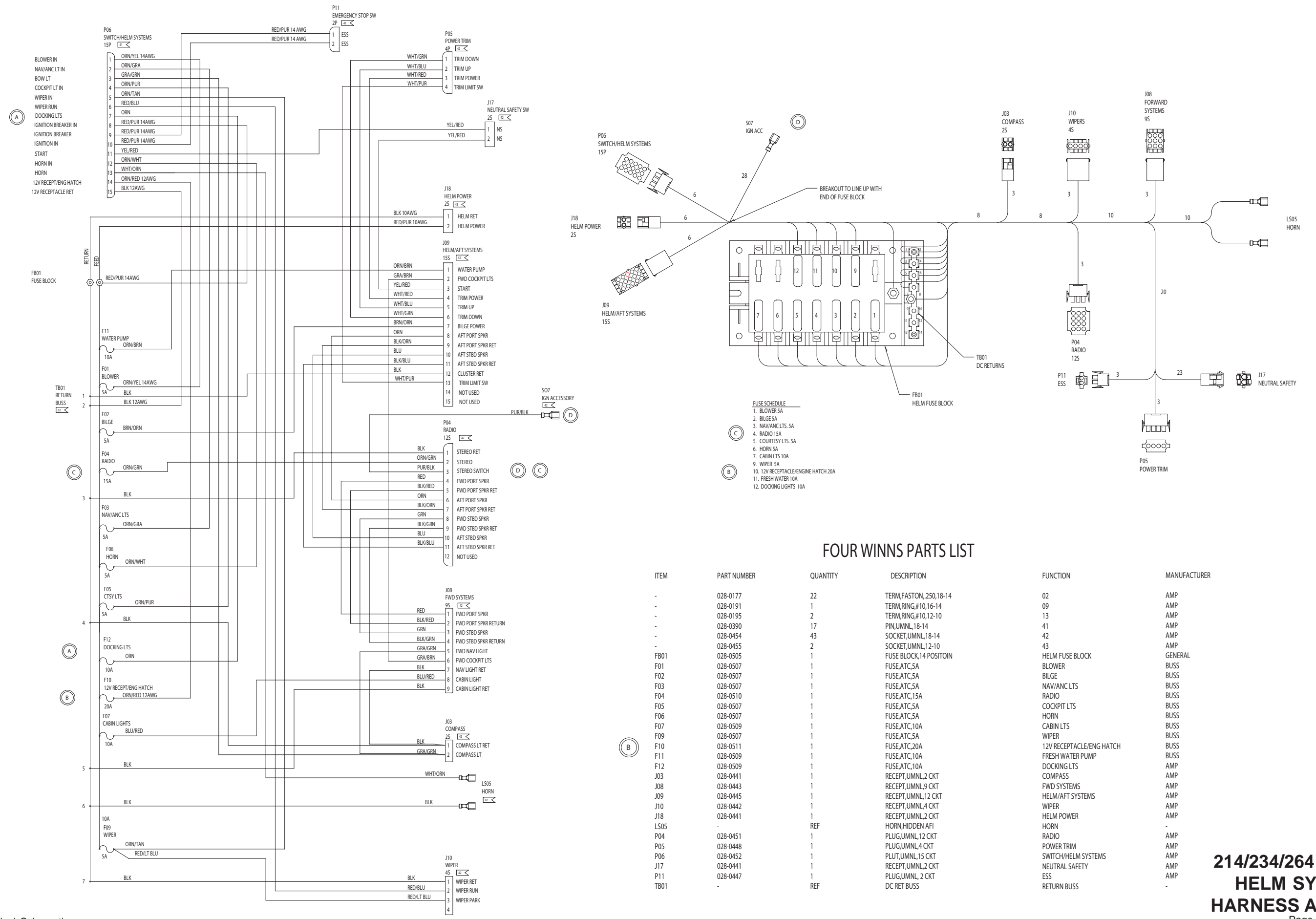

FUSE SCHEDULE

1. BLOWER SA
2. BILGE SA
3. NAV/ANC LTS. SA
4. RADIO 1SA
5. COURTESY LTS. SA
6. HORN SA
7. CABIN LTS 10A
9. WIPER SA
10. 12V RECEPTACLE/ENGINE HATCH 20A
11. FRESH WATER 10A
12. DOCKING LIGHTS 10A

FOUR WINNS PARTS LIST

ITEM	PART NUMBER	QUANTITY	DESCRIPTION	FUNCTION	MANUFACTURER
-	028-0177	22	TERM,FASTON,.250,18-14	02	AMP
-	028-0191	1	TERM,RING,#10,16-14	09	AMP
-	028-0195	2	TERM,RING,#10,12-10	13	AMP
-	028-0390	17	PIN,UMNL,18-14	41	AMP
-	028-0454	43	SOCKET,UMNL,18-14	42	AMP
-	028-0455	2	SOCKET,UMNL,12-10	43	AMP
FB01	028-0505	1	FUSE BLOCK,14 POSITON	HELM FUSE BLOCK	GENERAL
F01	028-0507	1	FUSE,ATC,5A	BLOWER	BUSS
F02	028-0507	1	FUSE,ATC,5A	BILGE	BUSS
F03	028-0507	1	FUSE,ATC,5A	NAV/ANC LTS	BUSS
F04	028-0510	1	FUSE,ATC,15A	RADIO	BUSS
F05	028-0507	1	FUSE,ATC,5A	COCKPIT LTS	BUSS
F06	028-0507	1	FUSE,ATC,5A	HORN	BUSS
F07	028-0509	1	FUSE,ATC,10A	CABIN LTS	BUSS
F09	028-0507	1	FUSE,ATC,5A	WIPER	BUSS
F10	028-0511	1	FUSE,ATC,20A	12V RECEPTACLE/ENG HATCH	BUSS
F11	028-0509	1	FUSE,ATC,10A	FRESH WATER PUMP	BUSS
F12	028-0509	1	FUSE,ATC,10A	DOCKING LTS	AMP
J03	028-0441	1	RECEPT,UMNL,2 CKT	COMPASS	AMP
J08	028-0443	1	RECEPT,UMNL,9 CKT	FWD SYSTEMS	AMP
J09	028-0445	1	RECEPT,UMNL,12 CKT	HELM/AFT SYSTEMS	AMP
J10	028-0442	1	RECEPT,UMNL,4 CKT	WIPER	AMP
J18	028-0441	1	RECEPT,UMNL,2 CKT	HELM POWER	AMP
LS05	-	REF	HORN,HIDDEN AFI	HORN	-
P04	028-0451	1	PLUG,UMNL,12 CKT	RADIO	AMP
P05	028-0448	1	PLUG,UMNL,4 CKT	POWER TRIM	AMP
P06	028-0452	1	PLUT,UMNL,15 CKT	SWITCH/HELM SYSTEMS	AMP
J17	028-0441	1	RECEPT,UMNL,2 CKT	NEUTRAL SAFETY	AMP
P11	028-0447	1	PLUG,UMNL,2 CKT	ESS	AMP
TB01	-	REF	DC RET BUSS	RETURN BUSS	-

**214/234/264 FUNSHIP
HELM SYSTEMS
HARNESS ASSEMBLY**
Page 6

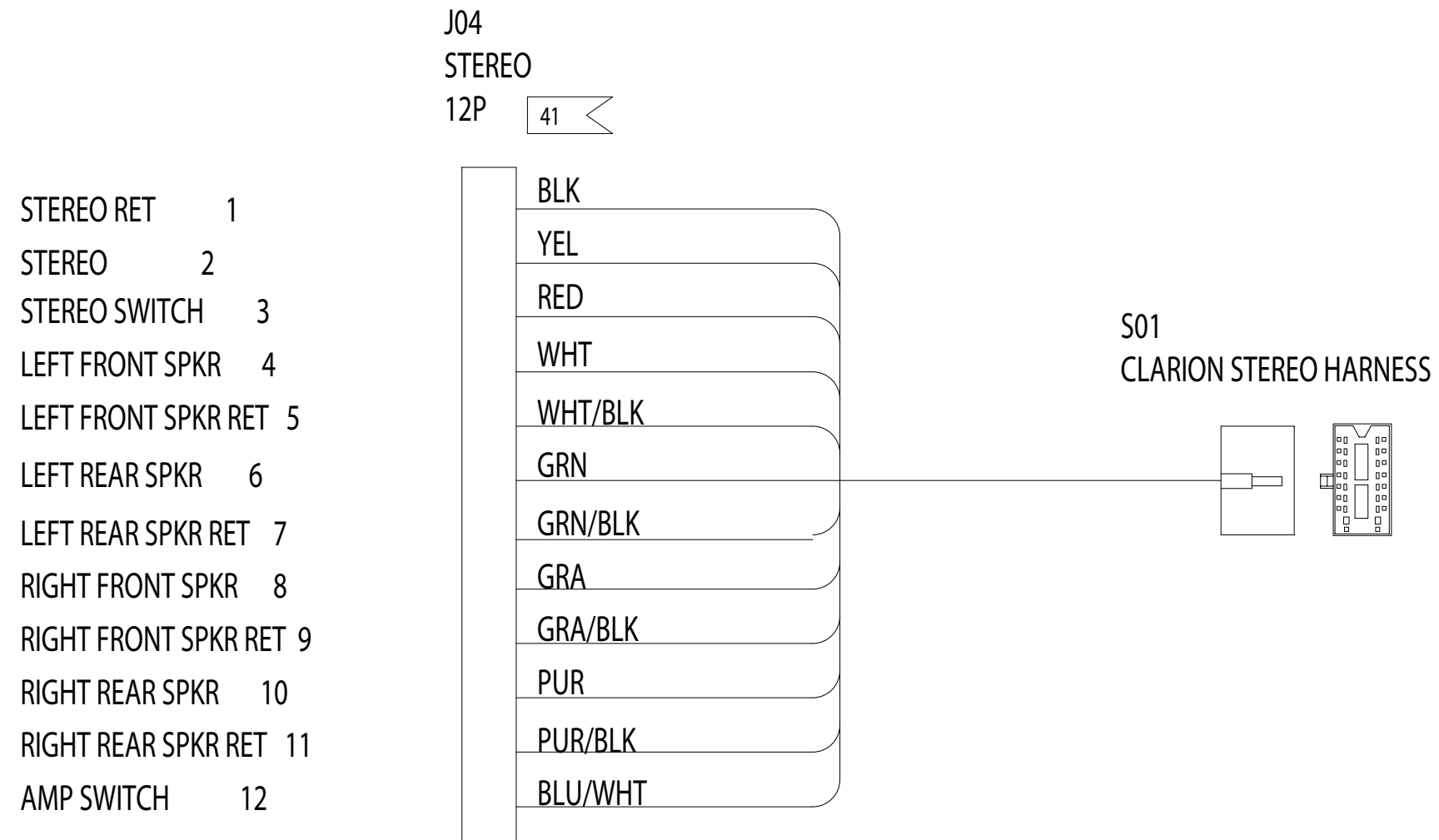

FOUR WINNS PARTS LIST

ITEM	PART NUMBER	QUANTITY	DESCRIPTION	FUNCTION	MANUFACTURER
	028-0390	3	PIN,UMNL,18-14	41	AMP
	028-1036	8	PIN,UMNL,24-18	57	AMP
J04	028-0445	1	RECEPT,UMNL,12 CKT	STEREO ADAPTOR	AMP
S01	027-2441	1	CLARION STEREO PLUG ASSY	CLARION STEREO	CLARION

CLARION STEREO ADAPTER HARNESS ASSEMBLY

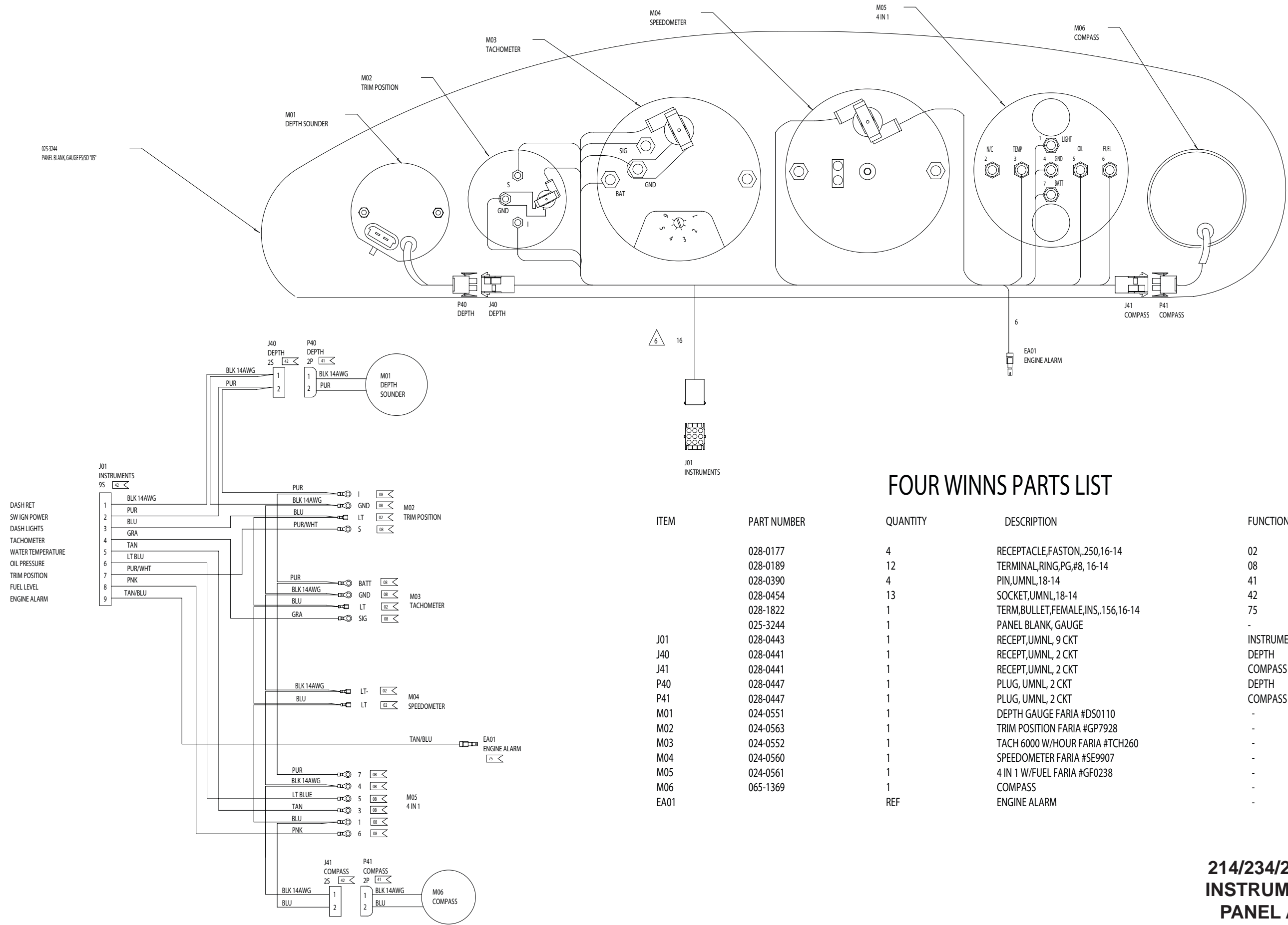

FOUR WINNS PARTS LIST

ITEM	PART NUMBER	QUANTITY	DESCRIPTION	FUNCTION	MANUFACTURER
	028-0177	4	RECEPTACLE,FASTON,,250,16-14	02	AMP
	028-0189	12	TERMINAL,RING,PG,#8, 16-14	08	AMP
	028-0390	4	PIN,UMNL,18-14	41	AMP
	028-0454	13	SOCKET,UMNL,18-14	42	AMP
	028-1822	1	TERM,BULLET,FEMALE,INS.,156,16-14	75	MOLEX
	025-3244	1	PANEL BLANK, GAUGE	-	-
J01	028-0443	1	RECEPT,UMNL, 9 CKT	INSTRUMENTS	AMP
J40	028-0441	1	RECEPT,UMNL, 2 CKT	DEPTH	AMP
J41	028-0441	1	RECEPT,UMNL, 2 CKT	COMPASS	AMP
P40	028-0447	1	PLUG, UMNL, 2 CKT	DEPTH	AMP
P41	028-0447	1	PLUG, UMNL, 2 CKT	COMPASS	AMP
M01	024-0551	1	DEPTH GAUGE FARIA #DS0110	-	FARIA
M02	024-0563	1	TRIM POSITION FARIA #GP7928	-	FARIA
M03	024-0552	1	TACH 6000 W/HOUR FARIA #TCH260	-	FARIA
M04	024-0560	1	SPEEDOMETER FARIA #SE9907	-	FARIA
M05	024-0561	1	4 IN 1 W/FUEL FARIA #GF0238	-	FARIA
M06	065-1369	1	COMPASS	-	RICHIE
EA01		REF	ENGINE ALARM	-	-

214/234/264 FUNSHIP INSTRUMENT GAUGE PANEL ASSEMBLY

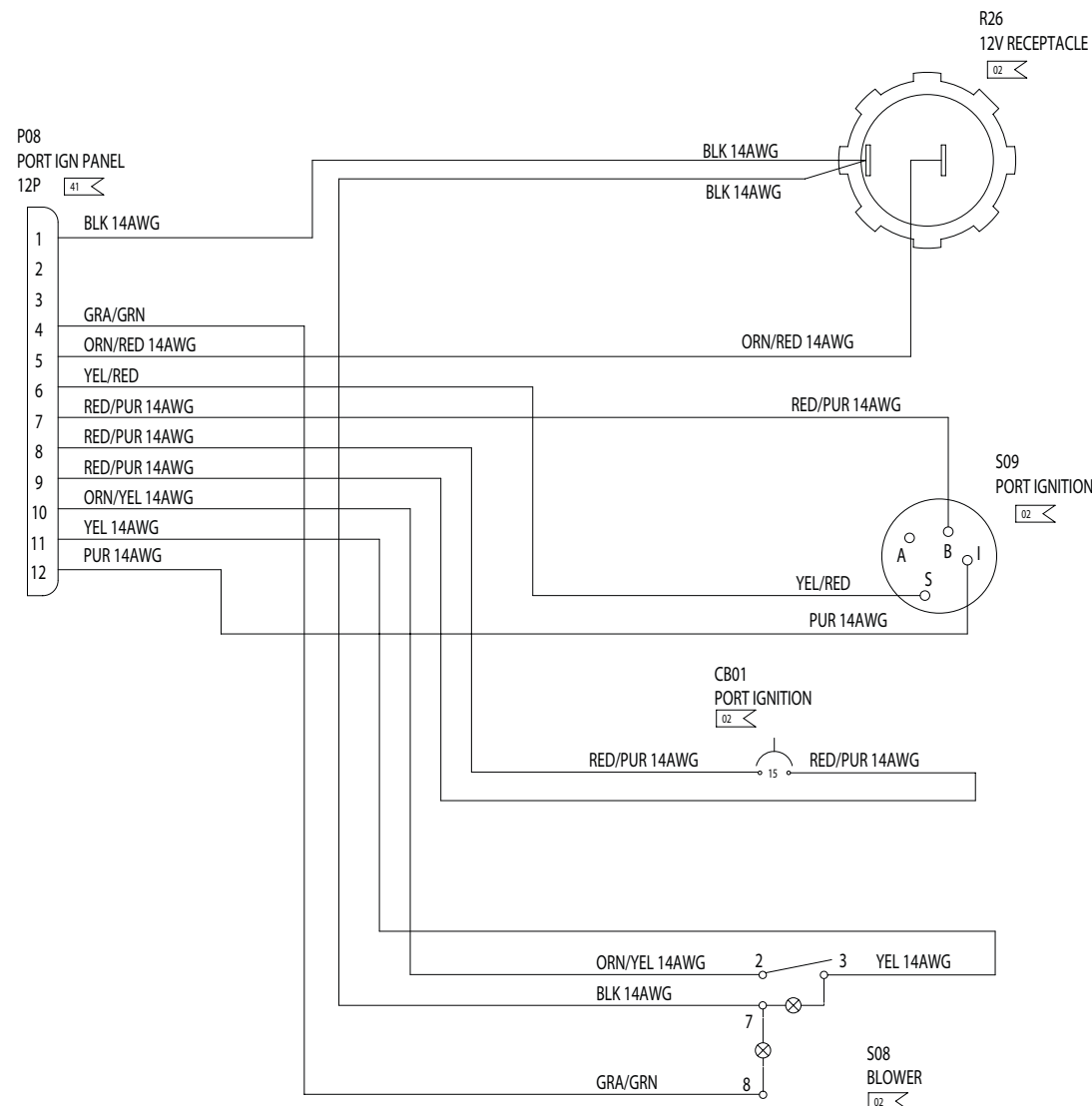

025-3248
PANEL, BLANK, IGN/SW PORT
BURL FS/SD "05"

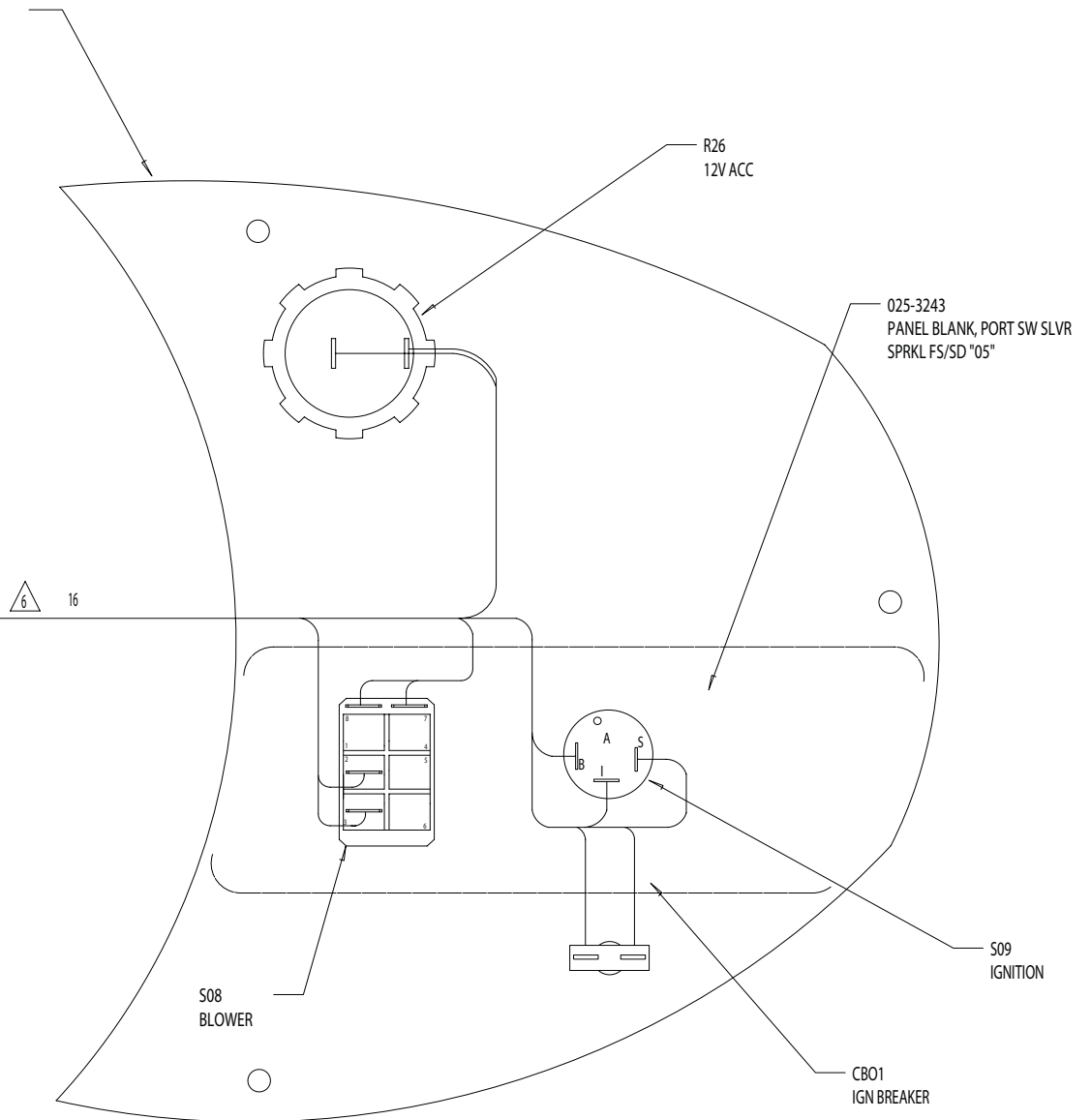
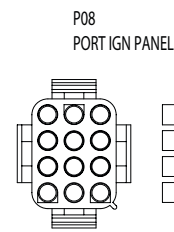

FOUR WINNS PARTS LIST

ITEM	PART NUMBER	QUANTITY	DESCRIPTION	FUNCTION	MANUFACTURER
-	028-0177	11	TERM,FASTON,,250,18-14	02	AMP
-	028-0454	10	PIN,UMNL,18-14	41	AMP
-	025-3248	1	PANEL,BLANK,IGNI/SW PORT	-	-
-	025-3243	1	PANEL BLANK, PT SW SLVR SPKPL	-	-
P08	028-0451	1	PLUG,UMNL,12 CKT	PORT IGN PANEL	AMP
R26	-	1	RECEPT,12V AFI	12V RECEPTACLE	AFI
S08	028-1901	1	SWITCH,SPST,CONT V	BLOWER	CARL SW
CB01	028-0467	1	CKT BREAKER, 15A	IGNITION BREAKER	MP
S09	028-1286	1	SWITCH, IGNITION, I/O	IGNITION SWITCH	GENERAL

214/234/264 FUNSHIP PORT IGNITION/SWITCH PANEL ASSEMBLY

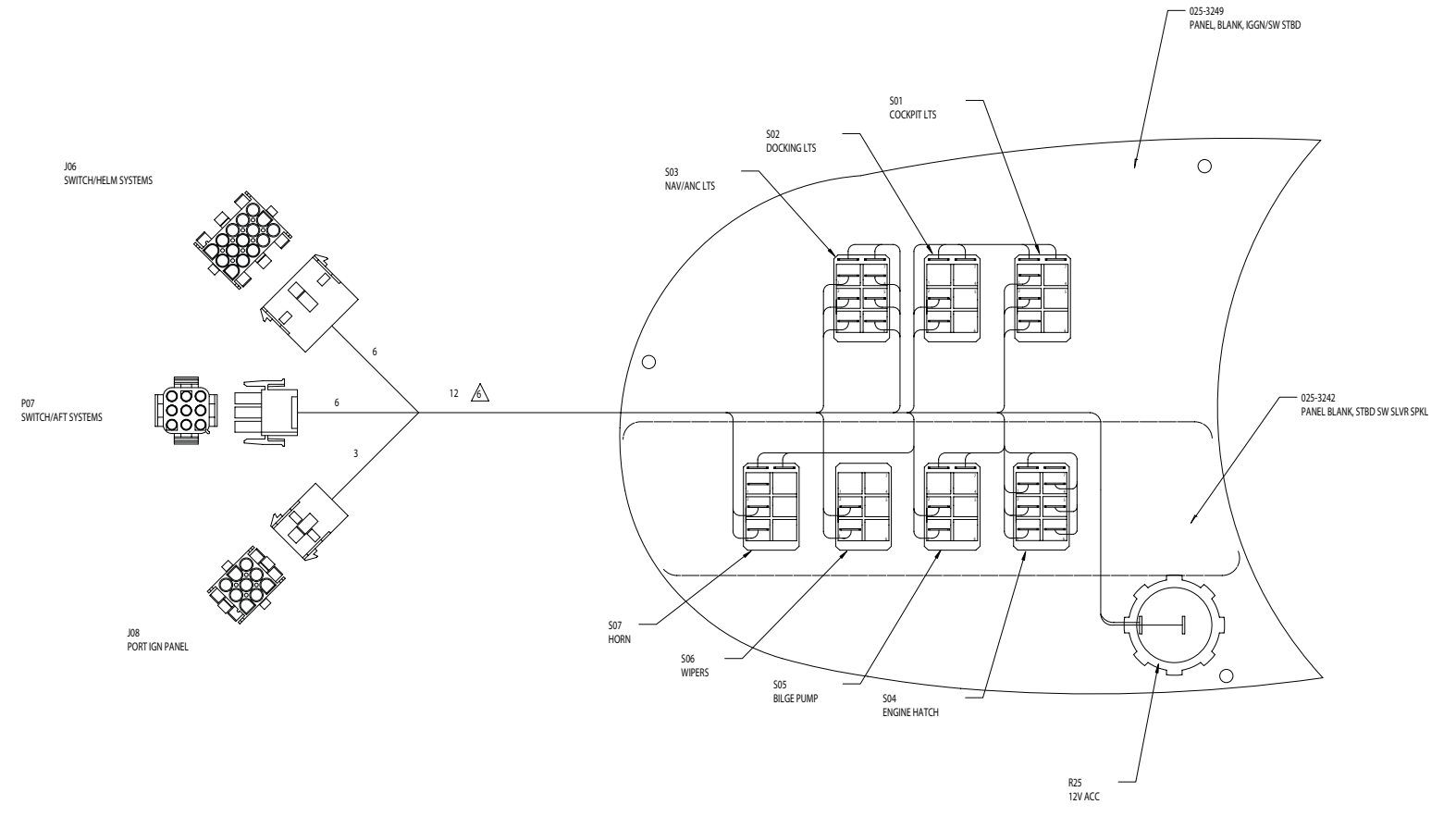
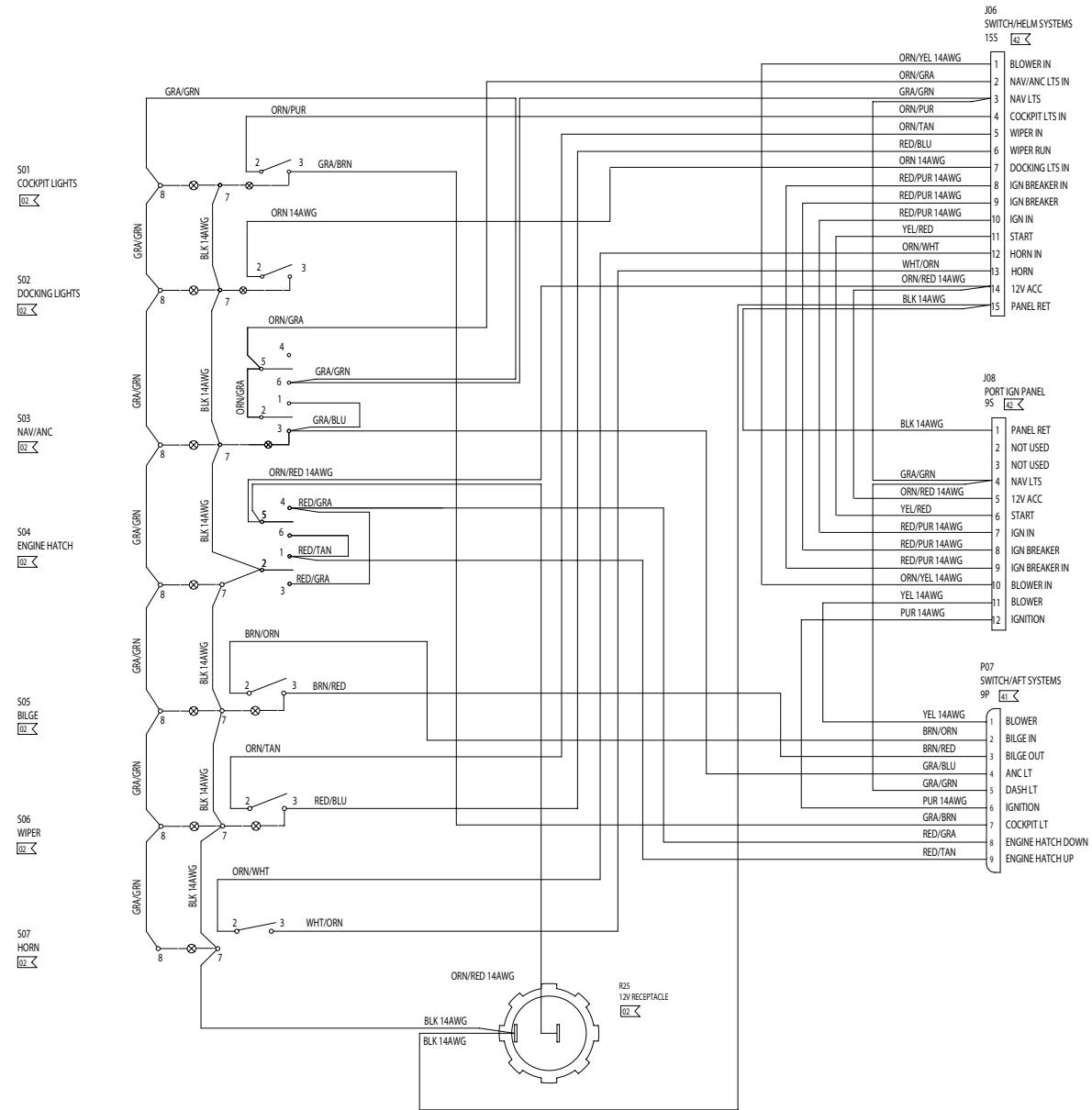

FOUR WINNS PARTS LIST

ITEM	PART NUMBER	QUANTITY	DESCRIPTION	FUNCTION	MANUFACTURER
-	028-0177	36	RECEPT,FASTON,,250,16-14	02	AMP
-	028-0390	9	PIN,UMNL,18-14	41	AMP
-	028-0454	25	SOCKET,UMNL,18-14	42	AMP
-	025-3249	1	PANEL, BLANK, STBD IGNITION SW	-	-
-	028-3242	1	PANEL,BLANK STBD SWITCH SILVER SPARKLE	-	-
J06	028-0452	1	RECEPT,UMNL,15 CKT	SWITCH/HELM	AMP
J08	028-0443	1	RECEPT,UMNL,9 CKT	PORT IGN PANEL	AMP
P07	028-0449	1	PLUG,UMNL,9 CKT	SWITCH AFT	AMP
R25	028-1100	1	RECEPTACLE,12V DC AFI	12V ACCESSORY PLUG	AFI
S01	028-1894	1	SWITCH,SPST,ON-OFF,CONTURA V	COCKPIT LTS	CARLING
S02	028-1903	1	SWITCH,SPST,ON-OFF,CONTURA V	DOCKING LTS	CARLING
S03	028-1899	1	SWITCH,DPDT,ON-OFF-ON,CONTURA V	NAV/ANC LTS	CARLING
S04	028-1898	1	SWITCH,SPST,(ON)-OFF,CONTURA V	EN	CARLING
S05	028-1897	1	SWITCH,SPDT,ON-OFF,CONTURA V	BIL	CARLING
S06	028-1895	1	SWITCH,SPST,ON-OFF,CONTURA V	WII	CARLING
S07	028-1896	1	SWITCH,SPST,(ON)-OFF,CONTURA V	HC	CARLING

214/234/264 FUNSHIP STBD HELM SWITCH PANEL ASSEMBLY

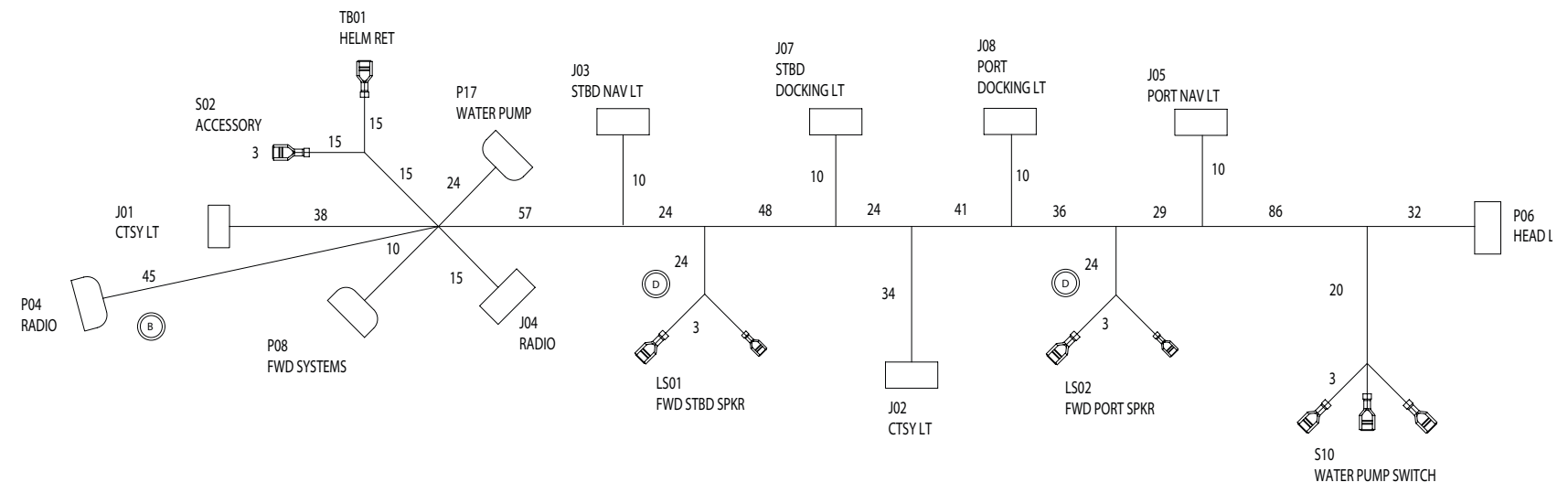
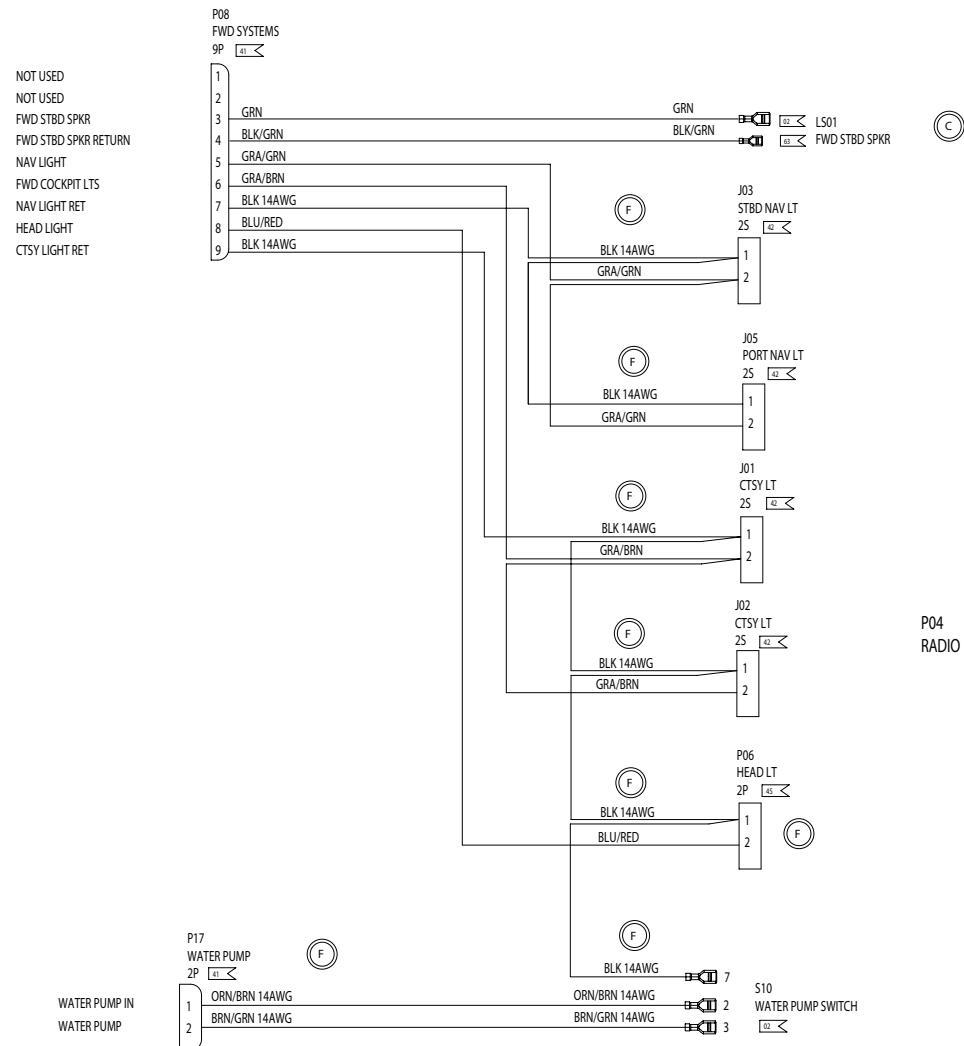

FOUR WINNS PARTS LIST

ITEM	PART NUMBER	QUANTITY	DESCRIPTION	FUNCTION	MANUFACTU
-	028-0177	7	TERM,FASTON,,250,18-14	02	AMP
-	028-0390	18	PIN,UMNL,18-14	41	AMP
-	028-0454	23	SOCKET,UMNL,18-14	42	AMP
-	028-0159	2	SOCKET,CMNL,20-14	45	AMP
-	028-1248	2	TERM,FASTON,,205,18-14	63	AMP
J01	028-0441	1	RECEPT,UMNL,2 CKT	CTS Y LT	AMP
J02	028-0441	1	RECEPT,UMNL,2 CKT	CTS Y LT	AMP
J03	028-0441	1	RECEPT,UMNL,2 CKT	STBD NAV LT	AMP
J04	028-0445	1	RECEPT,UMNL,12 CKT	RADIO	AMP
J05	028-0441	1	RECEPT,UMNL,2 CKT	PORT NAV LT	AMP
J07	028-0441	1	RECEPT,UMNL,2 CKT	STBD DOCKING LT	AMP
J08	028-0441	1	RECEPT,UMNL,2 CKT	PORT DOCKING LT	AMP
P04	028-0451	1	PLUG,UMNL,12,CKT	RADIO	AMP
P06	028-0161	1	HOUSING,SCKT 2CKT	HEAD LT	AMP
LS01	-	REF	SPEAKER	FWD STBD SPKR	-
LS02	-	REF	SPEAKER	FWD PORT SPKR	-
P17	028-0447	1	PLUG,UMNL,2 CKT	WATER PUMP	AMP
P08	028-0449	1	PLUG,UMNL,9 CKT	FWD SYSTEMS	AMP
S02	028-0457	REF	SWITCH,SPST,CONT III	DOCKING LTS SW	-
S10	028-0457	REF	SWITCH,SPST,CONT III	WATER PUMP SW	-
TB01	-	REF	HELM RET	HELM RET	-

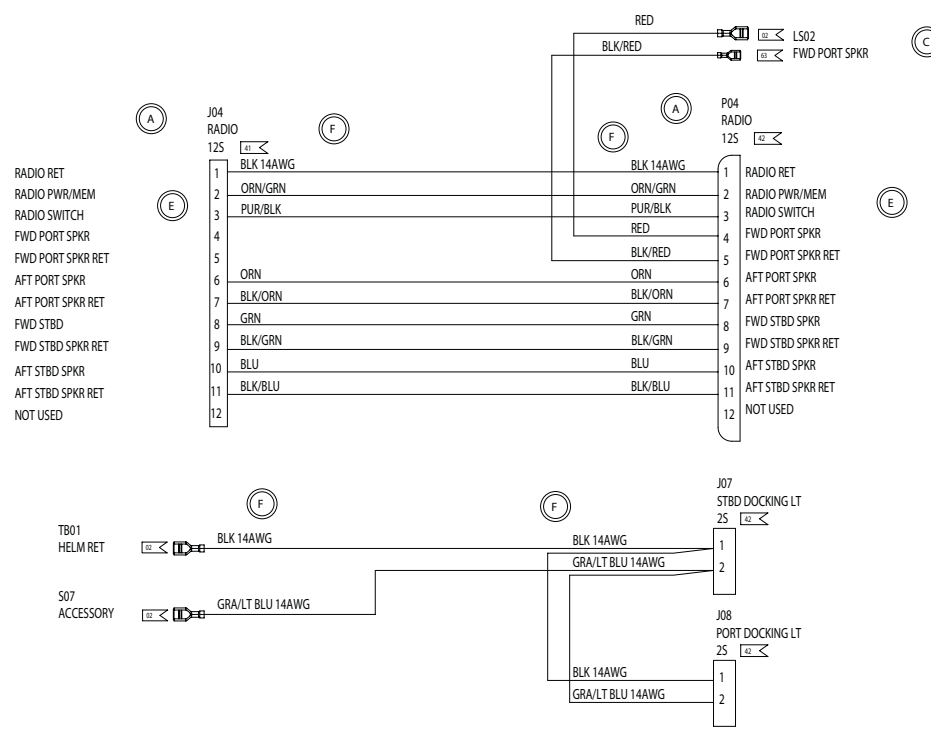

NOTES:

214/234/264 FUNSHIP FORWARD SYSTEMS HARNESS ASSEMBLY

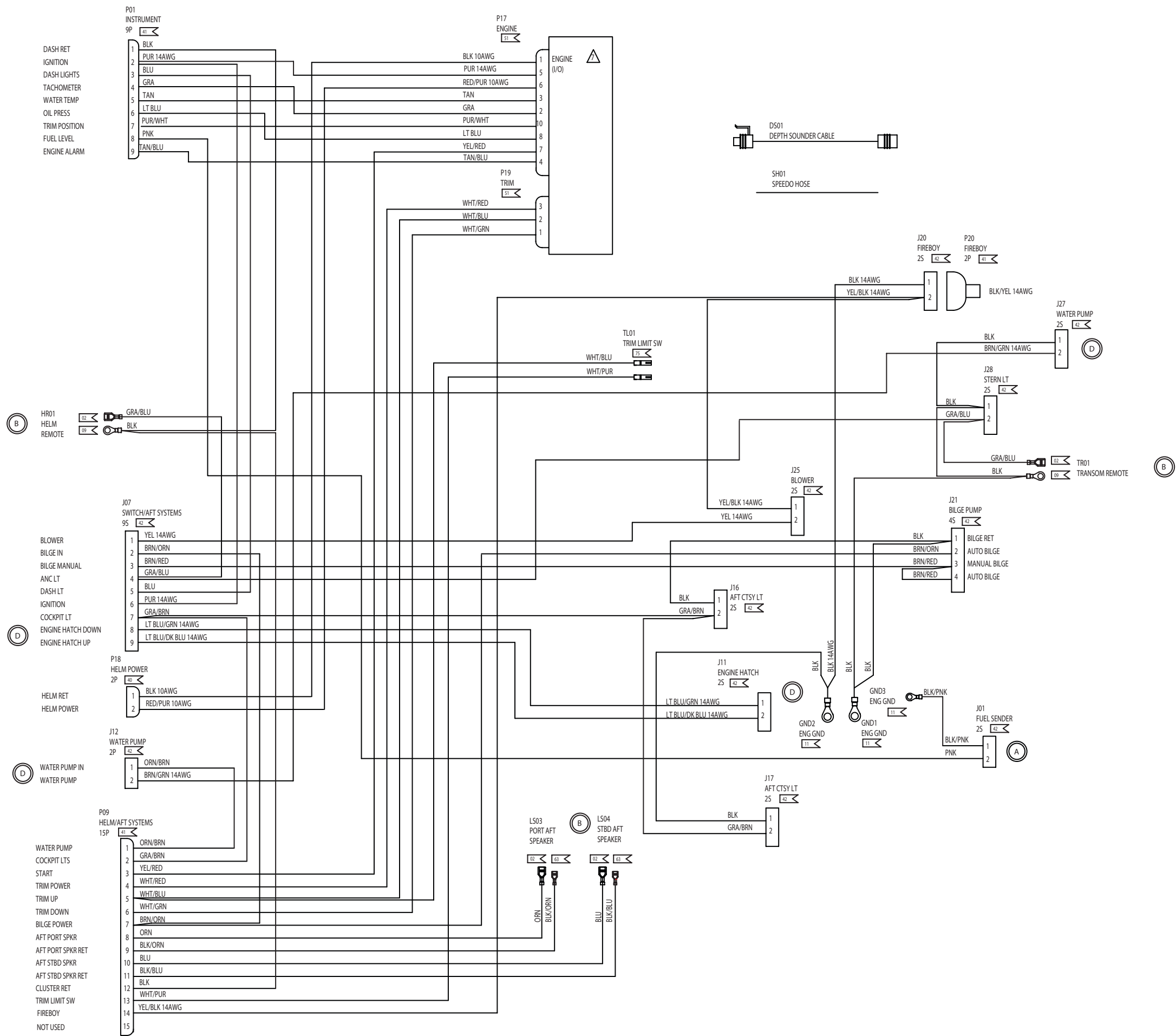

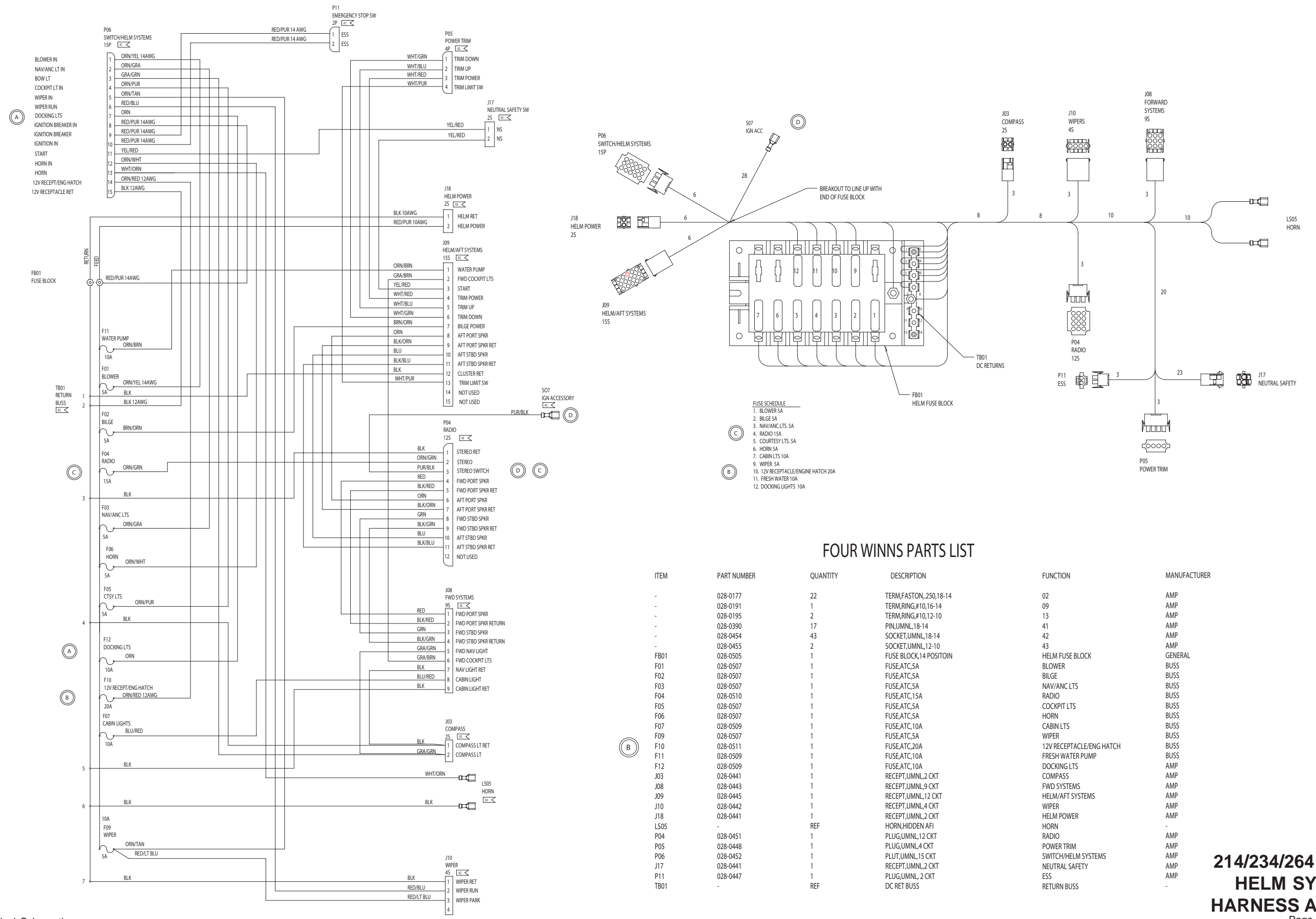

FUSE SCHEDULE

1. BLOWER SA
2. BILGE SA
3. NAV/ANC LTS. SA
4. RADIO 1SA
5. COURTESY LTS. SA
6. HORN SA
7. CABIN LTS 10A
9. WIPER SA
10. 12V RECEPTACLE/ENGINE HATCH 20A
11. FRESH WATER 10A
12. DOCKING LIGHTS 10A

FOUR WINNS PARTS LIST

ITEM	PART NUMBER	QUANTITY	DESCRIPTION	FUNCTION	MANUFACTURER
-	028-0177	22	TERM,FASTON,.250,18-14	02	AMP
-	028-0191	1	TERM,RING,#10,16-14	09	AMP
-	028-0195	2	TERM,RING,#10,12-10	13	AMP
-	028-0390	17	PIN,UMNL,18-14	41	AMP
-	028-0454	43	SOCKET,UMNL,18-14	42	AMP
-	028-0455	2	SOCKET,UMNL,12-10	43	AMP
FB01	028-0505	1	FUSE BLOCK,14 POSITON	HELM FUSE BLOCK	GENERAL
F01	028-0507	1	FUSE,ATC,5A	BLOWER	BUSS
F02	028-0507	1	FUSE,ATC,5A	BILGE	BUSS
F03	028-0507	1	FUSE,ATC,5A	NAV/ANC LTS	BUSS
F04	028-0510	1	FUSE,ATC,15A	RADIO	BUSS
F05	028-0507	1	FUSE,ATC,5A	COCKPIT LTS	BUSS
F06	028-0507	1	FUSE,ATC,5A	HORN	BUSS
F07	028-0509	1	FUSE,ATC,10A	CABIN LTS	BUSS
F09	028-0507	1	FUSE,ATC,5A	WIPER	BUSS
F10	028-0511	1	FUSE,ATC,20A	12V RECEPTACLE/ENG HATCH	BUSS
F11	028-0509	1	FUSE,ATC,10A	FRESH WATER PUMP	BUSS
F12	028-0509	1	FUSE,ATC,10A	DOCKING LTS	AMP
J03	028-0441	1	RECEPT,UMNL,2 CKT	COMPASS	AMP
J08	028-0443	1	RECEPT,UMNL,9 CKT	FWD SYSTEMS	AMP
J09	028-0445	1	RECEPT,UMNL,12 CKT	HELM/AFT SYSTEMS	AMP
J10	028-0442	1	RECEPT,UMNL,4 CKT	WIPER	AMP
J18	028-0441	1	RECEPT,UMNL,2 CKT	HELM POWER	AMP
LS05	-	REF	HORN,HIDDEN AFI	HORN	-
P04	028-0451	1	PLUG,UMNL,12 CKT	RADIO	AMP
P05	028-0448	1	PLUG,UMNL,4 CKT	POWER TRIM	AMP
P06	028-0452	1	PLUT,UMNL,15 CKT	SWITCH/HELM SYSTEMS	AMP
J17	028-0441	1	RECEPT,UMNL,2 CKT	NEUTRAL SAFETY	AMP
P11	028-0447	1	PLUG,UMNL,2 CKT	ESS	AMP
TB01	-	REF	DC RET BUSS	RETURN BUSS	-

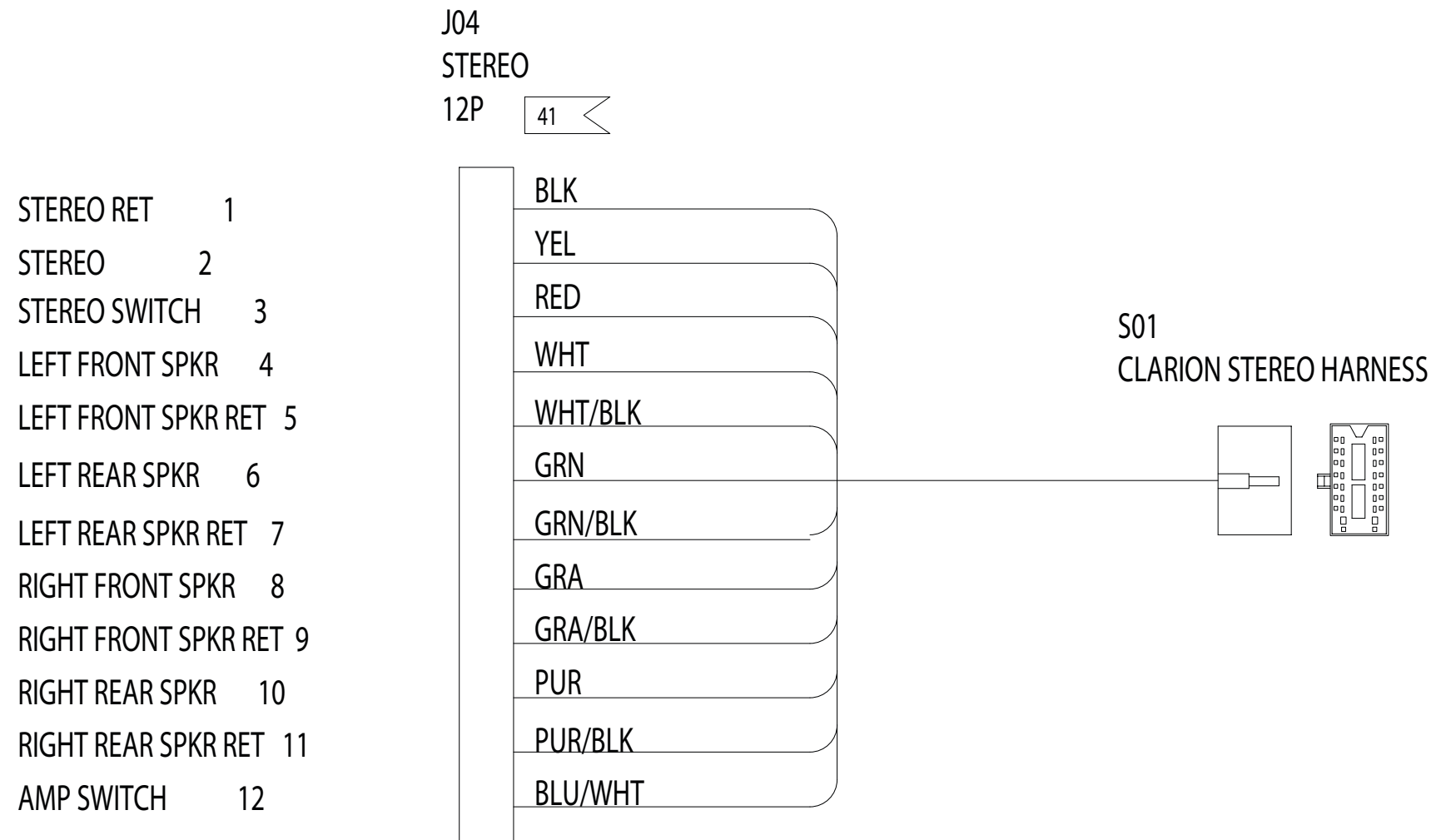

FOUR WINNS PARTS LIST

ITEM	PART NUMBER	QUANTITY	DESCRIPTION	FUNCTION	MANUFACTURER
	028-0390	3	PIN,UMNL,18-14	41	AMP
	028-1036	8	PIN,UMNL,24-18	57	AMP
J04	028-0445	1	RECEPT,UMNL,12 CKT	STEREO ADAPTOR	AMP
S01	027-2441	1	CLARION STEREO PLUG ASSY	CLARION STEREO	CLARION

CLARION STEREO ADAPTER HARNESS ASSEMBLY



FOUR WINNS®

Four Winns L.L.C.

Part # 090-2686