

 **FOUR WINNS®**

090-2854

318 VISTA® OWNERS MANUAL





WARNING

A wide variety of components used on this vessel contain or emit chemicals known to the State of California to cause cancer and birth defects and other reproductive harm.

EXAMPLES INCLUDE:

- Engine and generator exhaust
- Engine and generator fuel, and other liquids such as coolants and oil, especially used motor oil
- Cooking fuels
- Cleaners, paints, and substances used for vessel repair
- Waste materials that result from wear of vessel components
- Lead from battery terminals and from other sources such as ballast or fishing sinkers

TO AVOID HARM:

- Keep away from engine, generator, and cooking fuel exhaust fumes
- Wash areas thoroughly with soap and water after handling the substances above

GM2203301



Dear Four Winns Owner,

On behalf of everyone at Four Winns, congratulations – and thank you for choosing a Four Winns boat.

Four Winns is committed to customer satisfaction. If you are not completely satisfied with any aspect of your boat's condition upon delivery – or if it does not meet your expectations at any time during your ownership experience – please contact your Four Winns Dealer or our customer service department. In the event they are unable to assist you, or if you do not receive the response you expect, I invite you to contact me directly. Your feedback is invaluable to us as we strive to become the world's most customer-focused recreational boat brand.

A thorough review of this Owner's Manual will help you make the most of your boating experience. It not only includes information specific to the model you have purchased, but guidelines for better boating as well. Please take time to familiarize yourself with its contents, and to read – and reread often – important sections.

Once again, thank you and welcome to the Four Winns family.

Sincerely,

A handwritten signature in black ink that reads 'Jeff Olson'.

Jeffrey Olson
President

Phone: 231 775-1351

Fax: 231 779-2345

Email: boating@fourwinns.com



PREFACE	9
SAFETY MESSAGES	10
OPERATION	17
A - 1 GENERAL	17
A - 2 COMPONENT SYSTEMS	17
A - 3 SAFETY EQUIPMENT	17
A - 4 PASSENGER SAFETY	17
A - 5 RULES OF THE ROAD	17
A - 6 LIGHTNING.....	17
A - 7 DRUGS AND ALCOHOL.....	18
A - 8 PRE-CRUISE SYSTEM CHECK	18
A. Before Starting The Engines	18
B. After Starting The Engine	18
A - 9 ENGINE OPERATIONAL PROCEDURES	19
A. Before Starting	19
B. Cold /Warm Engine Start (EFI).....	19
C. Shifting and Control Speed.....	19
D. Stopping Engine.....	20
A - 10 GROUNDING AND TOWING	20
A - 11 BOATING EDUCATION	21
A. Boating Courses.....	21
B. Boating Manuals or Literature	21
C. Charts and Maps.....	21
D. Laws and Regulations	21
A - 12 BOAT OWNER REGISTRATION	22
A - 13 ACCIDENT REPORTING	22
A - 14 DISCHARGE OF OIL	22
A - 15 DISPOSAL OF PLASTICS & OTHER GARBAGE	22
A - 16 MARPOL TREATY	23
BOATING SAFETY	24
B - 1 GENERAL	24
A. Required Safety Equipment	24
B. Personal Flotation Devices (PFDs).....	24
C. PFD Types.....	24
D. PFD Pointers	25
E. Fire Extinguisher	25
F. Fire Extinguisher System	26
G. Visual Distress Signal Devices	26
H. Sound Signaling Devices	26
I. Navigation Lights.....	27
J. Additional Recommended Equipment	27
B - 2 CARBON MONOXIDE.....	27
A. Properties and Characteristics of Carbon Monoxide.....	28
B. What Makes Carbon Monoxide	28
C. How a Person is Affected by Carbon Monoxide.....	28
D. Effects of Carbon Monoxide	28
E. Symptoms.....	28
F. Treatment (Evaluate, Ventilate, Evacuate, Investigate, Take Corrective Action).....	28
G. Inspection.....	29

H. Operation	29
I. Boathouses, Sea Walls and Confined Spaces	29
J. The Effect of Boats Moored Along Side	30
K. Backdrafting (Station Wagon Effect)	30
L. Accumulation of Exhaust Gases-Swim Platform	31
M. Dangerous Activity - "Teak Surfing"/"Dragging"	31
N. Cabin Appliances	31
O. Air Conditioning	31
P. Ventilation of Accommodation (Occupied) Spaces	31
Q. Running of Engines in Idle	31
R. Altitude and Sea Conditions	31
S. Portable Generator Sets	32
T. Maintenance - Engine Performance	32
U. Maintenance - External Conditions	32
V. Maintenance - Exhaust System Integrity	32
W. Maintenance - Ventilation Systems	33
X. Maintenance - Bulkhead and Deck Integrity	33
Y. Maintenance - Air Conditioning Systems	33
Z. Maintenance - Liquid Drains	33
AA. Carbon Monoxide Monitor	33
B - 3 SAFE BOATING PRACTICES	34
A. Drugs and Alcohol	34
B. Safe Operation	34
C. Passenger Safety	34
D. Propeller	35
E. First Aid	35
F. Operation By Minors	35
G. "Rules of the Road"	35
H. Voluntary Inspections	35
I. Safe Boating Courses	35
B - 4 WATER SPORTS	36
A. Water Sport Guidelines	36
B. Water Skiing/Wakeboarding/Kneeboarding	36
BASIC SEAMANSHIP	38
C - 1 GENERAL	38
A. Boating Regulations	38
B. Rules of Seamanship	38
C - 2 NAVIGATIONAL AIDS	40
A. International Association of Lighthouse Authorities System B (IALA-B)	40
B. Lateral Markers	40
C. Safe Water Markers	40
D. The Uniform State Waterway Marking System	41
E. A Special Sign	41
F. Noise	41
G. Anchoring	41
C - 3 RECOMMENDED READING	42
C - 4 CONTACTS	42
C - 5 OWNER'S LOGS AND RECORDS	43
C - 6 NAVIGATIONAL AIDS CHART	43

WARRANTY AND SERVICE	44
D - 1 FOUR WINNS WARRANTY POLICY	44
D - 2 DECK/HULL STRUCTURE WARRANTY	44
D - 3 WARRANTY REGISTRATION	44
D - 4 TRANSFER OF WARRANTY	44
D - 5 PRE-OWNED UNIT REGISTRATION	44
D - 6 INSURANCE COVERAGE	45
D - 7 SERIAL NUMBER RECORD.....	45
D - 8 PRE-DELIVERY SERVICE.....	45
D - 9 REPLACEMENT PARTS.....	45
D - 10 OWNER'S RESPONSIBILITIES.....	45
D - 11 CONSTRUCTION STANDARDS.....	46
D - 12 WINNGEAR.....	46
D - 13 NAME/ADDRESS CHANGE FORM	47
D - 14 WARRANTY REGISTRATION TRANSFER REQUEST	49
ENGINES AND INSTRUMENTATION	51
E - 1 GENERAL	51
E - 2 ENGINE EXHAUST.....	51
A. Carbon Monoxide.....	51
B. Carbon Monoxide Monitor	52
E - 3 ENGINE & Drive System	52
A. Engine.....	52
B. Stern Drive	53
E - 4 PROPELLERS	53
A. Diameter	53
B. Pitch.....	53
C. Prop Slip	53
E - 5 ENGINE COOLING SYSTEMS	54
A. Raw Water Cooling	54
B. Fresh Water Cooling	55
E - 6 RUNNING ANGLE & POWER TRIM/TILT	55
A. Power Trim.....	55
B. Power Tilt.....	56
E - 7 TRIM TABS	56
A. Control Listing	56
B. Induce Planing & Controlling Trim Angle	56
C. Trim Tab Maintenance	57
E - 7 INSTRUMENTATION	57
A. Tachometer/Hour Meter Gauge.....	57
B. Speedometer	58
C. Temperature Gauge (Included in 4-in-1 Gauge).....	58
D. Oil Pressure Gauge (Included in 4-in-1 Gauge).....	58
E. Voltmeter (Included in 4-in-1 Gauge).....	58
F. Fuel Gauge (Included in 4-in-1 Gauge)	58
G. Power Trim Gauge	59
H. Gas Vapor Detector	59
I. Engine Hour Meter	59
J. Ignition Switch.....	59
K. Alarm Systems.....	59
L. Navagational Equipment	59
M. Instrument Maintenance.....	61

CONTROL SYSTEMS	62
F - 1 GENERAL	62
F - 2 CONTROL OPERATION	62
A. General	62
B. Maneuvering Dual Binnacle Controls	62
C. Shifting and Control Speed	63
F - 3 NEUTRAL SAFETY SWITCH	64
F - 4 CONTROL SYSTEM MAINTENANCE	64
STEERING SYSTEMS	65
G - 1 GENERAL	65
A. Tilt Steering Rotary Steering	65
B. Rotary Steering	65
C. Power Steering	65
G - 2 STEERING LOAD	66
G - 3 PROPELLER TORQUE	66
G - 4 STEERING SYSTEM MAINTENANCE	66
ELECTRICAL SYSTEMS	67
H - 1 GENERAL	67
H - 2 DUAL ENGINE–TRIPLE BATTERY SYSTEM	67
A. Installation	67
B. Operation	67
H - 3 BATTERY CHARGER	68
H - 4 VOLTMETER	68
H - 5 12 VOLT ELECTRICAL EQUIPMENT	68
A. Helm Equipment	68
B. Installation of Additional 12 Volt Equipment	69
C. Interior Equipment	70
H - 6 12 VOLT ELECTRICAL SYSTEM SHUTDOWN PROCEDURES	70
H - 7 120 (220) VOLT ELECTRICAL SYSTEM	70
H - 8 DOCKSIDE OPERATION	71
A. Shore Power Connections	71
B. 120 Volt AC Equipment	72
C. Reverse Polarity Indicator	73
D. Ground Fault Current Interrupters (GFCI)	73
H - 9 GENERATOR	73
H - 10 ELECTRICAL SYSTEM MAINTENANCE	74
A. Battery Maintenance	74
B. Electrical Wiring Maintenance	75
H - 11 STRAY CURRENT CORROSION	75
A. General	75
B. Galvanic Corrosion	75
C. Corrosion Prevention	75
FUEL SYSTEMS	79
I - 1 GASOLINE FUEL SYSTEMS	79
A. System Testing	79
B. Fuel Fills	79
C. Fuel Vents	80
D. Anti-Syphon Valves	80
E. Fuel Gauge	81

	F. Fuel Senders.....	81
	G. Fuel Filters	81
	H. Gas Vapor Detector	81
	I. Use and Maintenance	82
I - 2	FUEL STANDARDS	82
	A. Problems With Alcohol in Gasoline.....	82
	B. Recommendations	82
I - 3	FUELING INSTRUCTIONS	83
WATER AND WASTE SYSTEMS		85
J - 1	GENERAL	85
J - 2	PRESSURIZED WATER SYSTEM.....	86
	A. Priming the System	86
	B. System Operation	86
	C. Water Heating Systems.....	86
	D. Using the Shower.....	87
J - 3	GREY WATER SYSTEM.....	87
J - 4	SHORE WATER CONNECTION	87
J - 5	TRANSOM SHOWER	88
J - 6	HEADS	88
	A. VacuFlush® Sanitation System	88
	B. Head With Overboard Discharge.....	89
	C. Dockside Waste Pump Out	90
J - 7	SYSTEM MAINTENANCE.....	90
	A. Clean Vents and Screens.....	90
	B. Winterizing the Water System	91
	C. Winterizing the Waste System.....	92
VENTILATION AND DRAINAGE SYSTEMS		112
K - 1	ENGINE COMPARTMENT VENTILATION.....	112
	A. Natural Ventilation System	112
	B. Forced Air Ventilation	112
	C. Engine Ventilation System Maintenance	112
K - 2	CABIN VENTILATION	112
K - 3	HULL DRAINAGE SYSTEMS.....	113
	A. Transom Drain	113
	B. Bilge Pumps.....	113
	C. Sump	113
	D. Bilge Compartment Drainage	114
	E. Cockpit Drainage.....	114
INTERIOR EQUIPMENT.....		115
L - 1	GALLEY EQUIPMENT	115
	A. Electric Stove	115
	B. Microwave Oven	115
	C. Refrigerator	115
L - 2	REFRESHMENT CENTER.....	115
L - 3	ENTERTAINMENT	116
	A. Stereo System	116
	B. TV and DVD Player.....	116
L - 4	AIR CONDITIONING	117

EXTERIOR EQUIPMENT	127
M - 1 RAILS & DECK HARDWARE	127
M - 2 TRANSOM DOOR.....	127
M - 3 COMPANIONWAY DOOR.....	128
M - 4 WINDOWS	128
A. Windshields and Cabin Windows	128
B. Plexiglass.....	129
M - 5 FOREDECK HATCHES	129
M - 6 SWIM PLATFORM	130
M - 7 COCKPIT STORAGE.....	130
M - 8 TRANSOM STORAGE LOCKER	131
M - 9 BOW PLATFORM	131
M - 10 WINDLASS.....	131
M - 11 RADAR ARCH.....	132
M - 12 SPOTLIGHT	132
M - 13 ENGINE HATCH W/ ELECTRIC LIFT	132
 UPHOLSTERY	 134
N - 1 INTERIOR SEATING.....	134
A. Couch and Dinette Table.....	134
B. V-berth or Forward Cabin.....	134
C. Mid Cabin (Aft Cabin) Berth.....	135
N - 2 EXTERIOR SEATING	135
A. Helm Seat	135
B. Stern Seat	136
C. Port Settee Lounge	136
D. Cockpit Table	137
E. Deck Sunpads.....	137
N - 3 INTERIOR UPHOLSTERY CARE	137
A. Cleaning Interior Fabric/Upholstery	137
B. Interior Carpets	138
C. Privacy Curtains.....	138
N - 4 EXTERIOR UPHOLSTERY CARE	139
A. Cleaning Vinyl	139
B. Exterior Carpets	140
C. Cleaning and Maintenance.....	140
D. Stain Removal Testing	141
D. Stain Removal Procedures.....	141
N - 5 REPLACEMENT UPHOLSTERY	141
 WEATHER COVERS	 142
O - 1 GENERAL INFORMATION	142
O - 2 GENERAL CANVAS INSTALLATION GUIDELINES	142
O - 3 TRAILERING	143
O - 4 BIMINI TOP	143
O - 5 CAMPER	145
O - 6 COCKPIT COVER	146
O - 7 USE OF WEATHER COVERS AND CARBON MONOXIDE	147
O - 8 WINTER STORAGE	148
O - 9 MAINTENANCE	148

FIBERGLASS AND HULL	149
P - 1 HULL DESIGN INFORMATION.....	149
P - 2 FIBERGLASS CONSTRUCTION	149
P - 3 EQUIPMENT INSTALLATION.....	149
P - 4 FIBERGLASS CARE & MAINTENANCE.....	149
A. General Maintenance.....	149
B. Weathering Effects on Gel Coat.....	150
C. Stains.....	151
P - 5 FIBERGLASS REPAIRS	151
A. Scratches	151
B. Gouges & Cracks.....	152
C. Osmotic Blistering	152
P - 6 ANTI-FOULING PAINT.....	153
P - 7 HULL SUPPORT.....	153
 WOODWORK AND COMPOSITES	 155
Q - 1 HIGH-PRESSURE LAMINATE CARE	155
Q - 2 CHERRY	155
Q - 3 STAR BOARD.....	155
Q - 4 LAMINATED FIBERGLASS.....	155
Q - 5 VINYL COVERED MEDIUM DENSITY FIBERBOARD (MDF).....	155
Q - 6 WOODGRAIN ENHANCEMENTS.....	156
Q - 7 FIBERGLASS COUNTERTOP W/ SOLID SURFACE INLAY	156
Q - 8 SOLID SURFACE MATERIAL.....	156
Q - 9 ACRYLIC PLASTIC (PLEXIGLASS).....	157
Q - 10 FLEXITEEK.....	157
 GENERAL MAINTENANCE	 158
R - 1 WINTERIZATION	158
A. Prior to Lifting for Winter Lay up	158
B. After Lifting.....	158
C. Prior to Winter Storage.....	159
R - 2 ENGINE FLUSH OUT	159
A. Volvo Penta® Engine Flush Out (Four Winns Installation).....	159
B. MerCruiser® Engine Flush Out Option	160
R - 3 GENERAL MAINTENANCE SCHEDULE	161
 PRE-LAUNCH AND UNDERWAY	 164
S - 1 LAUNCH & CRUISE CHECKLIST	164
S - 2 FUELING.....	165
A. Recommendations	165
B. Preliminary Guidelines	165
C. Pumping Fuel.....	165
D. After Fueling.....	165
S - 3 LOADING PASSENGERS & GEAR	166
S - 4 STARTING PROCEDURES	166
A. Preliminary Checks	166
S - 5 MANEUVERING.....	167
A. Leaving the Dock	167
B. Stopping.....	167

S - 6	ACCELERATION.....	168
S - 7	TRIMMING YOUR BOAT	168
	A. Trim Tabs	168
	B. Tilt/Trim Control Switches	169
S - 8	NAVIGATION LIGHTS.....	169
S - 9	HAZARDOUS CONDITIONS.....	170
	A. Storms	170
	B. Fog.....	170
	C. Running Aground	171
	B. Warning Markers.....	171
S - 10	REACTING TO EMERGENCIES.....	171
	A. Flooding	171
	B. Capsizing and Man Overboard	171
	C. Capsizing	171
	D. Man Overboard	171
	E. Collision	172
	F. Fire.....	172
	G. Medical Emergency.....	173
	H. Propulsion Failure	173
	I. Control Failure.....	173
	J. Steering Failure.....	173
	K. Additional Underway Information.....	173
S - 11	RETURNING TO SHORE.....	173
	A. Docking.....	173
	B. Mooring.....	174
GLOSSARY.....		175
FLOAT PLAN		182
FUEL LOG.....		183
SERVICE LOG		186
SERVICE INFORMATION		189
VISTA LOCATOR DRAWING		190
ELECTRICAL SCHEMATICS.....		191

Congratulations on your new boat purchase and welcome to our boating family!

We want your boating experience to be the most enjoyable possible. The more you know about your new boat, the more you'll enjoy the time you spend aboard. That's why we prepared this manual. It's your guide for safe operation as well as understanding your boat's system and equipment. It has been written for the beginning boater but experienced boaters will find helpful information as well. Be sure to read the contents thoroughly.

This manual will acquaint you with the use and maintenance of your new Four Winns boat. This manual also provides special information critical to the safety of the passengers, and longevity of the equipment. The information on the following page lists the graphics used to increase the visibility of these important messages. Also included in your owner's packet is the "Boating Basics, A Guide to Responsible Boating". This guide covers boating basics and should be read along with your Four Winns Owner's Manual before operating your boat. Review this information completely before using your new boat.

Four Winns continually strives to improve its products. Unit specifications, including standard and optional equipment are constantly being modified. **Equipment availability is also subject to change without notice. The most current and accurate information available at the time of publication is included in this manual. Some variation in material, equipment, description, location, and details can result.**

The information in this manual focuses upon the equipment designed and manufactured by Four Winns on specific models. When appropriate, please utilize the information pertinent to your specific boat model.

Equipment such as engines, and other accessories are manufactured by others. **The information provided in this manual is intended to be used in conjunction with the information provided by the manufacturers of this equipment.** All information available at the time of manufacture has been included with your owner's packet. In many cases, replacement of manufacturer's literature may be obtained via their respective websites.

Read this entire manual carefully before operating your new boat. Many instructions may require direct performance of the activity to fully understand the correct method. If you choose to read this manual at home, remember to take it to the boat with you.

Your Four Winns dealer knows your boat best and is committed to your complete satisfaction. Return to the dealer for service or other assistance. If you find it necessary to contact Four Winns directly, please refer to the contact information listed below. Be sure to include the boat model, hull identification number, your daytime telephone number, and specifics of the information desired.

This manual has been specifically developed for the 318 Vista® models. Please record the model and hull identification number information below.

Model

Hull Identification Number

This manual should be considered part of the boat. Should you sell the boat, pass this manual on to the new owner. Take special care of this manual. Certain information in this manual may not be available in a replacement manual. An electronic version of this manual may be viewed on our website at www.fourwinns.com.

Thank you for joining the Four Winns family. We appreciate your purchase and welcome the opportunity to demonstrate our commitment to you.

**Four Winns Customer Service
Department 925
Frisbie Street
Cadillac, Michigan 49601
231 775-1343 (Phone) 231 779-2345 (Fax)**

**E-Mail Address: boating@fourwinns.com
©FOUR WINNS LLC 2006. All Rights Reserved.**

The popularity of boating and other water sports has grown tremendously in the past few years. Because of this, safety is an important issue for everyone who shares our waterways.

Remember that along with the freedom and exhilaration of boating comes the responsibility that you have for the safety of your passengers and the other boaters who share the water with you. Throughout this manual, specific precautions and symbols identify safety-related information. Be sure to pay close attention to them.

IMPORTANT HEALTH AND SAFETY INFORMATION ABOUT YOUR NEW BOAT**NOTICE**

Boxes that are gray require your special attention. Notice boxes include helpful boating practices and law reminders.



This symbol means “pay attention!” Here is important information for your safety. If you don’t follow these instructions, you can damage your boat, hurt yourself or someone else or, even worse, have a fatal accident.

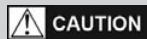

This symbol and signal word indicate a potentially hazardous situation. If you ignore this safety message, property damage or minor or moderate personal injury MAY or CAN result.



This symbol and signal word indicate a potential hazard. If you ignore this safety message, serious injury or death CAN result.



This symbol and signal word indicates an immediate hazard. If you ignore this safety message, serious personal injury or death WILL result.

The precautions in this manual can not and do not cover every boating situation. If a specific method or procedure is not recommended, you must make sure that what you do is safe for you and others. Always use common sense when boating! Remember to make sure that every safe boating excursion is a happy experience.

We’d also like to remind you to be kind to our environment while you’re boating. Don’t throw garbage and other refuse overboard. Do your best to keep harmful compounds like gasoline, oil and antifreeze out of the water. Please see the notifications below:

DISCHARGE OF OIL PROHIBITED

THE FEDERAL WATER POLLUTION CONTROL ACT PROHIBITS THE DISCHARGE OF OIL OR OILY WASTE INTO OR UPON THE NAVIGABLE WATERS OF THE UNITED STATES, OR THE WATERS OF THE CONTIGUOUS ZONE, OR WHICH MAY EFFECT NATURAL RESOURCES BELONGING TO, APPERTAINING TO, OR UNDER THE EXCLUSIVE MANAGEMENT AUTHORITY OF THE UNITED STATES, IF SUCH DISCHARGE CAUSES A FILM OR DISCOLORATION OF THE SURFACE OF THE WATER OR CAUSES A SLUDGE OR EMULSION BENEATH THE SURFACE OF THE WATER. VIOLATORS ARE SUBJECT TO SUBSTANTIAL CIVIL PENALTIES AND/OR CRIMINAL SANCTIONS INCLUDING FINES AND IMPRISONMENT.

Oil Discharge Plate - (Specific Models Only - Location Not Shown)

It is illegal for any vessel to dump plastic trash anywhere in the ocean or navigable waters of the United States. Annex V of the MARPOL TREATY is an

International Law for a cleaner, safer marine environment. Violation of these requirements may result in civil penalty up to \$25,000, fine and imprisonment.

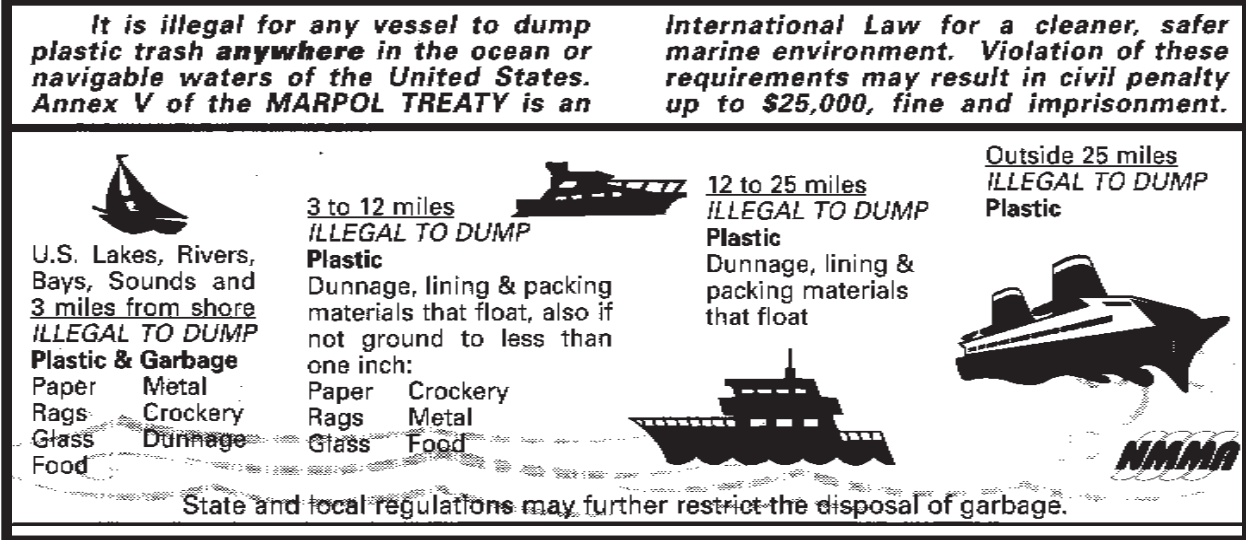

U.S. Lakes, Rivers, Bays, Sounds and 3 miles from shore
ILLEGAL TO DUMP Plastic & Garbage

Paper	Metal
Rags	Crockery
Glass	Dunnage
Food	

3 to 12 miles
ILLEGAL TO DUMP Plastic
Dunnage, lining & packing materials that float, also if not ground to less than one inch:
Paper Crockery
Rags Metal
Glass Food

12 to 25 miles
ILLEGAL TO DUMP Plastic
Dunnage, lining & packing materials that float

Outside 25 miles
ILLEGAL TO DUMP Plastic

State and local regulations may further restrict the disposal of garbage.



Trash Overboard Decal - (Specific Models Only - Location Not Shown)

This manual has been compiled to help you operate your boat with safety and pleasure. It contains the details of the boat, the equipment supplied or fitted, its systems, and information on its operation and maintenance. Please read it carefully and familiarize yourself with the boat before using it.

If this is your first boat, or if you are changing to a type of boat you are not familiar with, for your own comfort and safety, please ensure that you obtain handling and operating experience before "assuming command" of the boat. Your dealer or national sailing federation or yacht club will be pleased to advise you of local sea schools and competent instructors.

PLEASE KEEP THIS MANUAL IN A SECURE PLACE, AND HAND IT OVER TO THE NEW OWNER WHEN YOU SELL THE BOAT.

LABEL LOCATIONS

Various warning labels are placed at different locations on each model for your safety. Additional warnings for fuel leakage, blower operation, and other important information will be imprinted or located on the dash. Many of these stickers and labels are not required by the US Coast Guard but are important to ensure the safe operation of your Four Winns® boat. In addition, the Hull Identification Number plate is permanently attached below the deck-hull joint on the starboard aft corner.

Below are letters corresponding to the various locations for each item on the drawings. See the following pages of this section for the actual wording of each of the various warning labels found on your boat.

- | | |
|---|---|
| (A) Hull Identification Number Plate | (H) CO - Transom Warning Label |
| (B) Gasoline Vapor-Blower Warning
(applicable models only) | (I) Prevent Falls Overboard Label |
| (C) Rotating Prop Boarding Ladder | (J) Winning Edge Sticker |
| (D) Leaking Fuel | (K) NMMA Certified Sticker |
| (E) NMMA Yacht Certification Plate | (L) Shore Power Inlet Warning Label |
| (F) CO - Helm Warning Label | (M) Dockside Inlet Air Conditioning Label |
| (G) Helm Boarding Ladder Warning | |

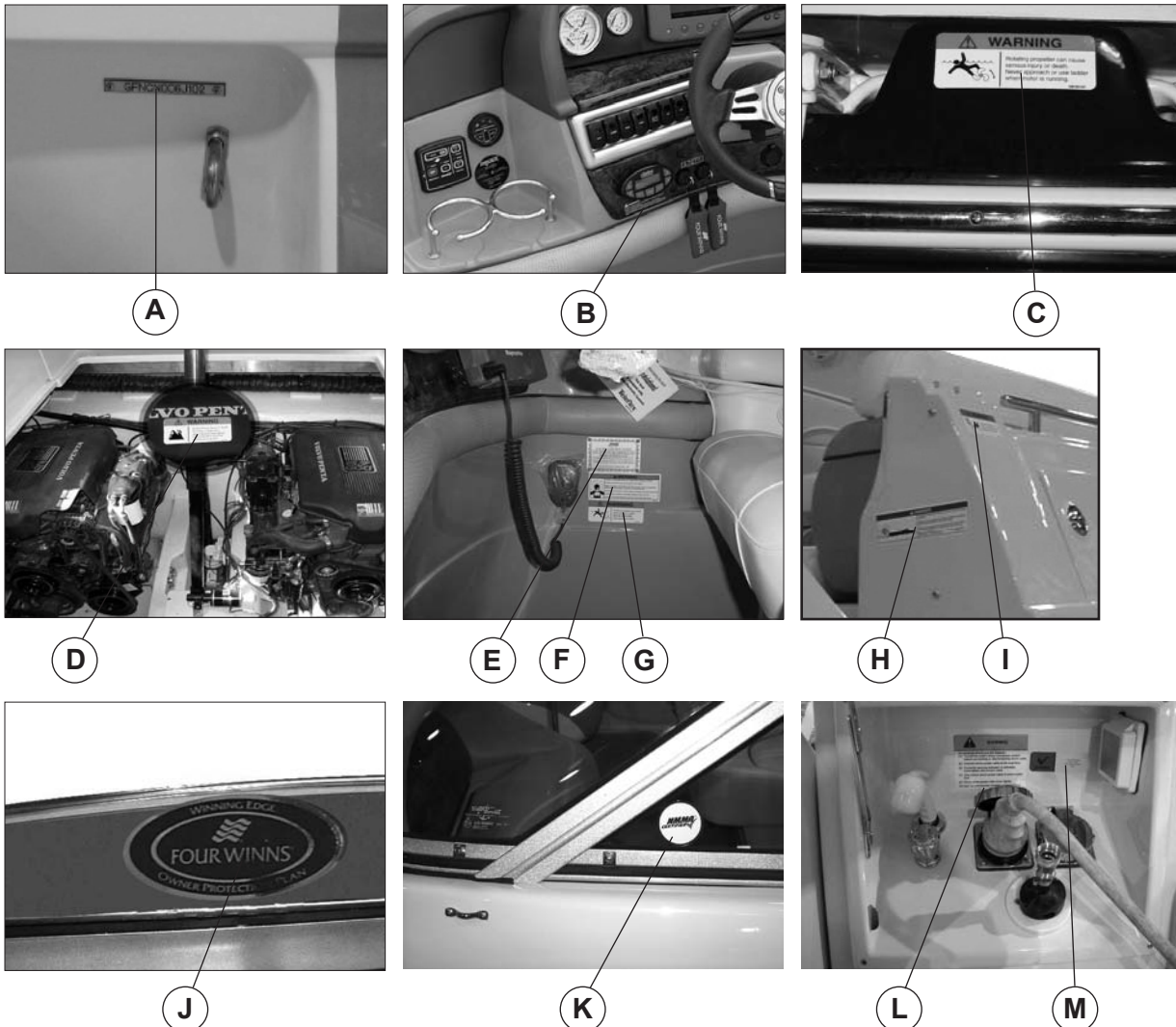

**Figure 1: Warning Labels and Other Label Locations - Reference Only
(Location may vary depending on model)**

YACHT CERTIFICATION & WARNING LABELS

NMMA Yacht Certification Plate

Gasoline Vapors - Blower Warning Label
(applicable models only)

 **WARNING**



GASOLINE VAPORS CAN EXPLODE RESULTING IN INJURY OR DEATH. BEFORE STARTING ENGINE

- CHECK ENGINE BILGE COMPARTMENT FOR GASOLINE OR VAPORS, AND
- OPERATE BLOWER FOR FOUR MINUTES, AND VERIFY BLOWER OPERATION.

RUN BLOWER WHEN VESSEL IS OPERATING BELOW CRUISING SPEED.

 Fisheries and Oceans Canada Coast Guard Pêches et Océans Canada Garde côtière Canada	
BUILDER - CONSTRUCTEUR FOUR WINNS BOATS, L.L.C. (GFN)	MODEL - MODÈLE MODEL NAME
THE MANUFACTURER CERTIFIES THAT THIS PRODUCT COMPLIES WITH THE CONSTRUCTION STANDARDS FOR SMALL VESSELS.	LE FABRICANT CERTIFIE QUE CE PRODUIT EST CONFORME AUX NORMES DE CONSTRUCTION DES PETITS BATEAUX.
NO. - no POYEXXXX	SAMPLE

Canadian Conformity Label

CE	FOUR WINNS SAMPLE - MODEL NAME/YEAR
0609	MAXIMUM
C	8  +  = 1134 kg

EU Builders Plate - CE Certification Plate (Export)

 **CAUTION**

Ensure slings are in proper location as indicated by the sling label location. Failure to do so may result in permanent hull structure damage and will invalidate the hull structure warranty.

SLING



 **WARNING**

To minimize shock and fire hazards:

- (1) Turn off the boat's shore connection switch before connecting or disconnecting shore cable.
- (2) Connect shore power cable at the boat first.
- (3) If polarity warning indicator is activated, immediately disconnect cable.
- (4) Disconnect shore power cable at shore outlet first.
- (5) Close shore power inlet cover tightly.

DO NOT ALTER SHORE POWER CONNECTORS

GM1850401

Shore Power Inlet Warning Label

 **WARNING**

 Fuel vapors are a fire and explosion hazard. To avoid injury or death, do not store fuel or flammable liquids here.

GM1850701

No Ventilation - Do Not Store Fuel Warning Label

 **WARNING**

 Exhaust fumes from engines contain carbon monoxide. To prevent fumes from entering cabin, keep door closed when engine or generator are running.

GM1850301

Carbon Monoxide - Cabin Doors Warning Label

 **WARNING**

Exhaust fumes from engines contain carbon monoxide. Boats with canvas deployed are more likely to collect exhaust fumes. Avoid brain damage or death from carbon monoxide. Keep cockpit and cabin areas well ventilated. Signs of exposure include nausea, dizziness, and drowsiness. See boat owner's manual for more details. If using a catalytic heater, provide ventilation. Do not use catalytic heater while sleeping.

Carbon Monoxide - Canvas Warning Label

 **EQUIPMENT**

THIS DOCKSIDE INLET FOR AIR CONDITIONING ONLY

Dockside Air Conditioning Inlet Label

 **CAUTION**

DO NOT RESTRICT AIR FLOW WHILE MICROWAVE IS IN USE, OR DAMAGE TO MICROWAVE OVEN OR CABINET MAY RESULT.

Microwave Caution Label

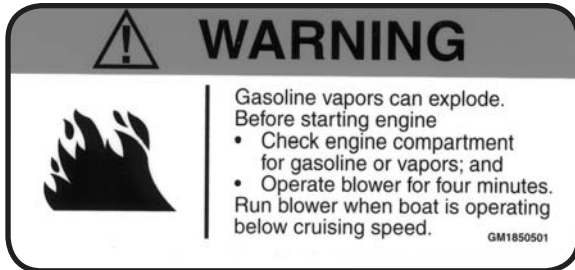

Gasoline Vapor-Blower Warning Label

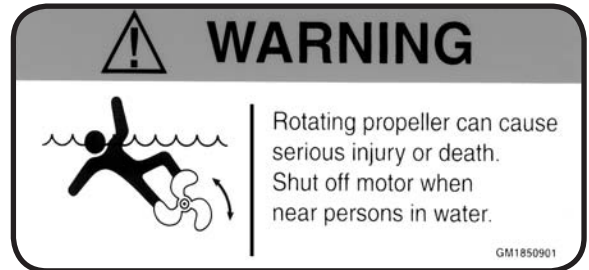

Rotating Propeller - Helm Warning Label

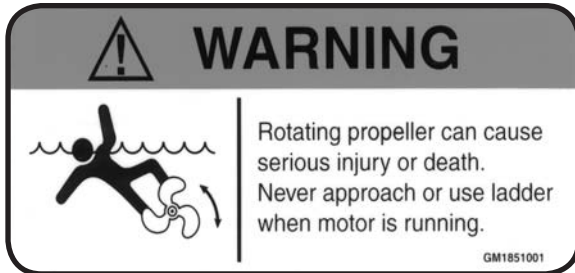

Rotating Propeller - Ladder Warning Label



Leaking Fuel Warning Label

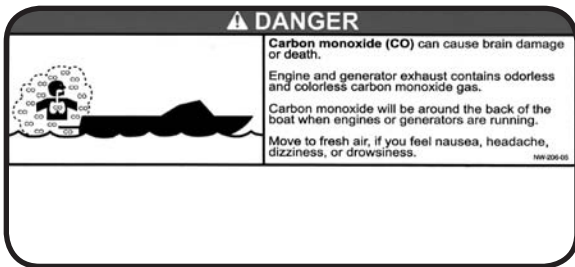

CO Swim Platform and Lounging Area Warning Label

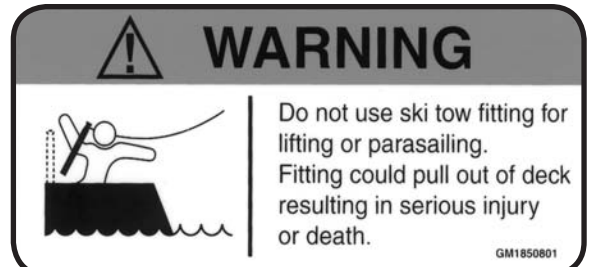

Ski Tow Warning Label

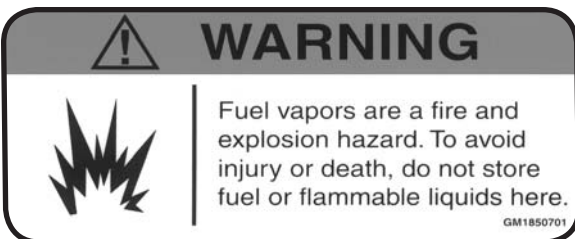

No Ventilation - Do Not Store Fuel Warning Label

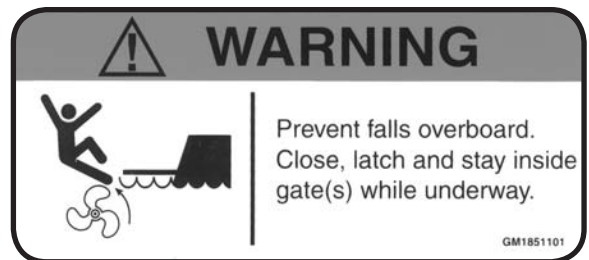

Transom/Side Door Warning Label

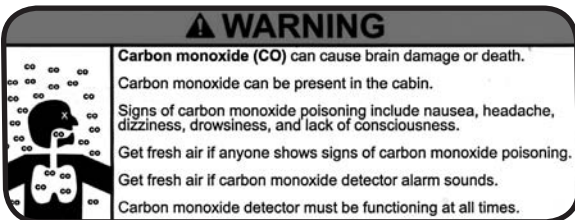

Co-Cabin Warning Label

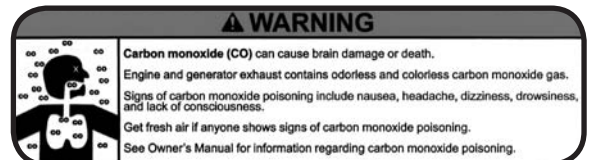

Co-Helm Warning Label



Winning Edge Sticker



NMMA Certified Sticker

WARNING

DO NOT USE FLUSHOUT
SYSTEM TO RUN ENGINE
WHILE OUT OF THE WATER

Flush Out Warning Label (Optional)

A - 1 GENERAL

Before starting the boat, become familiar with all of the various systems and related operations. Be sure all necessary safety equipment is on-board. Know the “Rules of the Road”. Have an experienced operator brief you on the general operation of your new boat. Perform a “pre-cruise systems check”. This manual is a part of your boat’s equipment. Always keep it on board.

A - 2 COMPONENT SYSTEMS

Before you can really enjoy your boat, a thorough understanding of its systems and their operation is essential. This manual and the associated manufacturers information are included in the owner’s packet. This information is provided to enhance your knowledge of the boat. Read this information carefully.

After becoming familiar with the boat and its systems, reread this manual and other material provided in the owner’s packet. Maintenance and service tips are included to help keep the boat in like-new condition.

A - 3 SAFETY EQUIPMENT

Besides the equipment installed on the boat by Four Winns certain other equipment is required for passenger safety. A booklet listing the Federal equipment requirements is included in the owner’s packet or is available through your local US Coast Guard Station. Remember that these laws are for your protection and are minimum requirements. Check your local and state regulations, also. More information on safety equipment is provided in Section B.

Items like a sea anchor, working anchor, extra dock lines, flare pistol, a line permanently secured to your ring buoy, etc. could at some time save your passengers lives, or save your boat from damage.

The Coast Guard Auxiliary offers a “Courtesy Examination.” This inspection will confirm the boat is equipped with all of the necessary safety equipment.

A - 4 PASSENGER SAFETY

You are responsible for the safety of your passengers as well as for their behavior while aboard. Make sure:

1. Each passenger is properly instructed in Personal Flotation Device (PFD) use and keeps one within reach in case of emergency. All non-swimmers and children should wear a PFD at all times when underway.
2. Passengers do not sit on gunwales, open decks, elevated pedestal seats or on seat backs when the boat is underway. This could cause them to be thrown overboard during a sudden maneuver.
3. At least one other person knows how to operate the boat in case of an emergency.

A - 5 “RULES OF THE ROAD”

As in driving an automobile, there are a few rules that must be known if safe boating operation is to be maintained. The Coast Guard, Coast Guard Auxiliary, Department of Natural Resources or your local boat club sponsor courses in boat handling, including “rules of the road”. Such courses are strongly recommended. Books on this subject are also available from local libraries.

A - 6 LIGHTNING

When boating, it is important to be aware of the weather around you. When the weather changes for the worse, DO NOT jeopardize your safety by trying to “ride out the storm”. If possible, return to safe harbor and dock your vessel immediately.

If caught in a storm, seek shelter inside the cabin and wait for the storm to pass. With certain models, campers will provide some protection, but should not be relied on if you are able to return to shore. Exercise care when high winds are present!

NOTICE

Four Winns boats are not equipped with a lightning protection system.



DO NOT swim or dangle legs or arms into the water during a lightning storm. Stay out of the water!

Lightning will seek a ground when it strikes. Avoid contact with metal parts such as bow rails, control handle, or windshield.

A - 7 DRUGS AND ALCOHOL

Please keep in mind that along with the fun of boating comes responsibility. As the owner or operator of a pleasure boat, you are obligated (morally and legally) to use good judgement while underway in providing for the safety and well-being of your passengers and other boaters around you.

A common and flagrant violation of good judgement and the law by boaters involves the use of alcohol or drugs. Each year, about half of all accidents involving fatalities involve the use of alcohol or drugs.

It is a federal offense to operate a boat while intoxicated. Criminal penalties may include the termination of operating privileges for up to one year. Many states have passed similar laws.

Alcohol or drugs have an inhibiting effect on the judgement and reaction time of the boat operator and his/her passengers. Heed the advice of experts and statisticians...DO NOT drink or use drugs when operating a boat. NEVER allow an obviously intoxicated person to take the helm.

Have fun in your Four Winns® boat, but also have the good sense to be mentally alert and physically capable of operating the boat in a safe manner.

A - 8 PRE-CRUISE SYSTEMS CHECK

Before leaving the dock, the following items should be checked:

A. Before Starting The Engine

1. Check the weather forecast. Determine if the cruise planned can be made safely.

2. Be sure all necessary safety equipment is on board and operative. This includes items such as the running lights, horn, spotlight, life saving devices, etc.
3. Check the bilge water level and bilge pump operation. Check the engine and drive fluid levels (if applicable). Look for other signs of potential problems. Check for the scent of fuel fumes.
4. Activate the Bilge Blower. Check the blower output.



Gasoline vapors can explode resulting in injury or death. Before starting the engine, check engine compartment bilge for gasoline or vapors. Operate blower for four minutes, and verify blower operation. ALWAYS run the blower when the vessel is operating below cruising speed.

5. Ensure an adequate amount of fuel is on board.
6. Be sure you have sufficient water and other provisions on board for the cruise planned.
7. Leave a written message listing details of the planned cruise with a close friend ashore.

B. After Starting The Engine

1. Visibly check the engine to be sure there are no apparent water or oil leaks.
2. Check the gauges. Make sure the oil pressure, water temperature, voltmeter, etc. are reading normally.
3. Have a safe cruise and enjoy yourself.



Always be sure to raise the anchor and ensure the chain stop is engaged prior to operating your boat. Failure to raise and secure anchor before getting underway could result in damage to boat and even severe injury or death from a rebounding anchor.

A - 9 ENGINE OPERATIONAL PROCEDURES

NOTICE

Consult engine operator's manual for specific procedure for your particular model. The following information is general in nature. Additional general information is located in Section S.

A. Before Starting

1. Check the engine compartment for water, gas, and/or oil leaks of any kind. Keep the bilge in a clean condition to prevent blower and bilge pump damage, and fire hazards.
2. Check the fluid levels of the engine oil and power steering system daily. Fill oil or steering fluid as required by the indications on the dip sticks. Refer to the Table 1: "SAE Viscosity Chart - Gas" and your engine manual included in the owner's packet. DO NOT USE MULTIGRADE OIL.

IF THE LOWEST ANTICIPATED TEMPERATURE IS*	THE FOLLOWING SAE VISCOSITY OILS ARE RECOMMENDED
32° F (0° C) and above	SAE 30
0° F (-18° C) to 32° F (0° C)	SAE 20W-20
Below 0° F (-18° C)	SAE 10W
*Temperature range you expect to operate. Note: Use only single viscosity oils.	

Table 1: SAE Viscosity Chart - Gas

Diesel engines use a Series IID oil, SAE15W/40. Refer to your diesel engine owner's manual for further information.

3. Power steering and power trim use automatic transmission fluid. Check the fluid levels in the vertical drive units or transmission as often as practical.
4. Start and operate the bilge blower system for at least four (4) minutes before start-up.
5. Lower the vertical outdrive units making sure the water intakes are under the water.

B. Cold / Warm Engine Start (EFI)

1. Move the control handle to NEUTRAL detent position.
2. Turn the key switch to start and hold until engine starts, for no longer than 10 seconds. If engine does not start, let go momentarily, then try again.
- 2b. For diesel engines, you must first turn the ignition key to the ON position and wait 30 seconds, allowing preheaters to activate. After 30 seconds, turn key switch to START position and hold until engine starts. DO NOT hold in START position for more than ten seconds.
3. As soon as engine starts, release key to ON or RUN.

NOTICE

Priming is not necessary for EFI engines. Refer to the engine owner's manual for additional information.

NOTICE

NEVER turn key to START position when engine is running.

NOTICE

When starting engine, do not allow engine to "over-rev". Engine damage could result. "Over-revving" engine after off-season storage could also damage the water pump impeller.

NOTICE

When starting engine for the first time after off-season storage, always idle engine for ten minutes to allow the water pump to prime.

C. Shifting and Control Speed

NOTICE

If your boat is equipped with a non-OEM remote control system, ask your dealer how to properly operate it.

1. Move shift/throttle lever(s) to the neutral idle position. Placing the shift/throttle levers in the neutral detent position will engage neutral start switch and allow engine to start.
2. To go FORWARD - move the shift/throttle lever(s) forward. Once forward gear engagement is complete, push shift/throttle lever(s) forward until desired speed is achieved.
3. To go in REVERSE - move the shift/throttle lever(s) rearward. Once rearward gear engagement is complete, push shift/throttle lever(s) rearward until desired speed is achieved.



DO NOT shift from forward to reverse when the boat is planing.

NOTICE

DO NOT shift if engine speed is above 800 RPM.

4. To go from FORWARD to REVERSE, or REVERSE to FORWARD; always pause at NEUTRAL and allow engine speed to return to idle.
5. After shifting is completed, slowly push throttle lever(s) forward/rearward until desired speed is achieved.



Any time the boat is operated, be aware of changes in shift system operation. A sudden increase in shift effort of the shifter levers, or other abnormal operation, indicates a possible problem in the shift system. If this occurs, the following precautions must be taken:

- With engine running and boat securely tied to the dock, shift drive into forward and reverse to ensure there is gear engagement.
- When docking the boat, all docking maneuvers must be performed at slow speed. Pay special attention to other boaters. Passengers should be informed of potential problems and precautions taken.

If you suspect there is a problem, see your engine manufacturer's authorized service center as soon as possible for proper diagnosis and required service or adjustment. Continued operation could result in damage to the shift mechanism and loss of control.

D. Stopping Engine

1. Move shifter lever(s) to the NEUTRAL position. Place throttle levers (if applicable) in idle position.
2. Turn ignition key to the OFF position.

NOTICE

DO NOT stop engine at speeds above idle or "speed up" engine while turning off ignition. Engine damage could result.

A - 10 GROUNDING AND TOWING



If the boat should become disabled, or if assisting another craft that is disabled, great care must be taken. The stress applied to a boat during towing may become excessive. Excessive stress can damage the structure of the boat and create a safety hazard for those aboard.

Four Winns® boats are not designed nor intended to be used as a towing vessel. The mooring cleats on Four Winns® boats are not designed or intended to be used for towing purposes. These cleats are specifically designed as mooring cleats for securing the boat to a dock, pier, etc. DO NOT use these fittings for towing or attempting to free a grounded vessel.

Freeing a grounded vessel or towing a boat that is disabled requires specialized equipment and knowledge. Line failure and structural damage caused by improper towing have resulted in fatal injuries. Because of this, Four Winns strongly suggests that these activities be left to those who have the equipment and knowledge such as the US Coast Guard or Sea Tow®, to safely accomplish the towing task.

 **CAUTION**

Running aground can cause serious damage to a boat and associated underwater gear. If the boat should become grounded, distribute personal flotation devices and inspect the boat for possible damage. Thoroughly inspect the bilge area for signs of leakage. An experienced service facility should check the hull and underwater gear at the first opportunity. DO NOT continue to use the boat if the condition of the hull or underwater equipment is questionable.

If towing or being towed is absolutely necessary, use the strongest lines available, and attach them to the bow eyes or stern eyes only. Have all passengers slip on life jackets and take a seat in the cabin or other protected area.

 **WARNING**

Lines can snap or other hardware can be loosened or broken while towing. Under certain conditions, this can cause severe injury or fatality.

A - 11 BOATING EDUCATION

A. Boating Courses

Boating education classes are offered throughout the country. The United States Coast Guard Auxiliary offers free courses on different topics usually during the off-season. The most popular course is the “Boating Skills & Seamanship Course,” and information can be obtained by calling 1 800-336-BOAT (2628) or by visiting their website at: www.boatus.com/courseline.

The United States Power Squadron also offers free courses ranging from basic seamanship to celestial navigation. For information, contact your local Power Squadron, or write: USPS, P.O. Box 30423, Raleigh, NC 27622 or visit their website at: www.usps.org.

The World Wide Web contains many websites devoted to boating and boating safety. One such site is www.discoverboating.com which contains many informative articles and website links for both the new boater as well as the experienced boater alike.

The Canadian Power and Sail Squadron offers seamanship courses. Information may be obtained by visiting their website at www.cps-ecp.ca/.

B. Boating Manuals or Literature

A good source of information is the US Coast Guard's home study book called “The Skipper's Course”. This book may be purchased through Superintendent of Documents, US Government Printing Office, Washington, DC 20402, Stock # 050-012-00159-6.

Another good source of boating information is Chapman's “Piloting, Seamanship and Small Boat Handling”. Also, check the local library or bookstore for additional information on boating.

C. Charts and Maps

US nautical charts are sold throughout the country at Governmental Printing Office stores and other agents. Chart catalogs are available by visiting the National Oceanic and Atmospheric Administration website at <http://nauticalcharts.noaa.gov/mcd/ccatalogs.htm#state>.

In addition, many federal agencies publish recreational maps, including the US Army Corp of Engineers, the Forest Service, the National Park Service, and the Tennessee Valley Authority.

Addresses of all state boating law administration offices are found in the “Boating Basics, A Guide to Responsible Boating”, included in your owner's packet. Additional copies may be purchased by contacting Outdoor Empire Publishing at www.outdoor-empire.com.

D. Laws and Regulations

The US Coast Guard is the authority of the waterways; they are there to help the boating public. State boating regulations are enforced by local authorities. You are subject to marine traffic laws and “Rules of the Road” for both federal and state waterways; you must stop if signaled to do so by enforcement officers, and permit to be boarded if asked.

There are many pamphlets, prepared by the US Coast Guard, available to you. These pamphlets explain “Rules of the Road,” signal lights, buoys, safety, international and inland regulations and other information which goes beyond the scope of this manual. For more information contact your local US Coast

Guard Unit or call the Coast Guard info line at 1 800 368-5647, or visit the US Power Squadron website at www.usps.org.

A - 12 BOAT OWNER REGISTRATION

Federal and state laws require that every boat equipped with propulsion machinery of any type must be registered in the primary state of usage. Registration numbers and validation stickers must be displayed on the boat according to regulations. In most states, this means registration with the designated state agency. In a few jurisdictions, the Coast Guard retains registration authority. Your dealer will either supply registration forms or tell you where they may be obtained. The registration agency will issue you a certificate that must be carried on board when the boat is in use. Some states require additional registration when an out of state boat is used within their boundaries.

Your boat has a hull identification number on the starboard side of the hull. Figure A-1 shows a typical identification number. Use this hull identification number for registration and to identify your boat for warranty service.

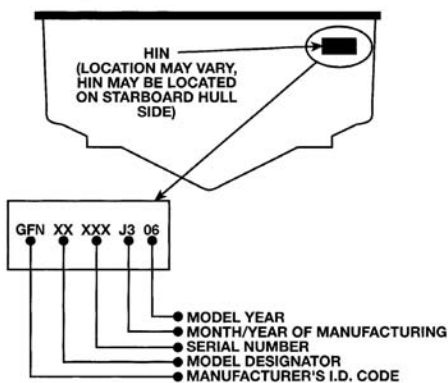

Figure A-1: HIN

In most states, the boat owner is legally responsible for damages or injuries he or she causes, even if someone else is operating the boat at the time of the accident. Common sense dictates that you carry adequate personal liability and property damage insurance on your boat, just as you would on an automobile. You should also protect your investment by insuring your boat against physical damage or theft.

A - 13 ACCIDENT REPORTING

The operator of the boat is responsible for filing a report with the appropriate authorities. In general, reports are necessary for accidents involving loss of life, injury, or damage over \$500. In the case of accidents with reportable injuries or death, a formal report is required within 48 hours. If only property damage is involved, a report must be made within ten days. The 1971 Boating Safety Act may impose a \$1,000 civil fine for people who fail to submit a boating accident report. Ask your insurance agent for more information.

If you see a distress signal, you must assume it is a real emergency and render assistance immediately. The master or person in charge of a boat is obligated by law to provide assistance to any individual in danger at sea. However, you should not put your boat or crew in a dangerous situation which exceeds your capabilities or those of your boat. The 1971 Boating Safety Act grants protection to a Good Samaritan boater offering good faith assistance, and absolves a boater from any civil liability arising from assistance given.

B - 14 DISCHARGE OF OIL

The Federal Water Pollution Control Act prohibits the discharge of oil waste into or upon the navigable waters of the United States or the waters of the contiguous zone if such discharge causes a film or sheen upon or a discoloration of the surface of the water or causes a sludge or emulsion beneath the surface of the water. Violators are subject to a penalty of \$5,000.

C - 15 DISPOSAL OF PLASTICS & OTHER GARBAGE

Plastic refuse dumped in the water can kill fish and marine wildlife and can foul boat propellers and cooling water intakes. Other forms of waterborne garbage can litter our beaches and make people sick. US Coast Guard and most state regulations prohibit the dumping of plastic refuse or other garbage mixed with plastic into the water anywhere, and restrict the dumping of other forms of garbage within specified distances from shore.

D - 16 MARPOL TREATY

Boats 26 feet or longer must display a sign stating the disposal regulations of the Federal Water Pollution Control Act. The US Coast Guard has issued these regulations to implement Annex V of the International Convention for the Prevention of Pollution from Ships, 1973, commonly known as Annex V of the MARPOL (Marine Pollution) Treaty 73/78. They apply to all US boats wherever they operate (except waters under the exclusive jurisdiction of a State) and foreign boats operating in US waters out to and including the Exclusive Economic Zone (200 miles). It is important to know these regulations and adhere to them.

The regulations require US recreational boaters, if your boat is 26 feet or more in length, to affix one or more USCG Trash Dumping Restrictions placards to your boat. The placard warns against the discharge of plastic and other forms of garbage within the navigable waters of the United States and specify discharge restrictions beyond the territorial sea. (The territorial sea generally ends three nautical miles from the seashore.) In addition, the placard must contain the warning that a person who violates these requirements is liable to civil (\$25,000) and criminal (imprisonment) penalties. The placard also must note that State and local regulations may further restrict the disposal of garbage.

Operators shall display one or more placards in a prominent location and in sufficient numbers so they can be observed and read by crew and passengers. These locations might include embarkation points, food service areas, galleys, garbage handling spaces and common deck spaces frequented by crew and passengers. We recommend that these placards may be purchased from local marinas, boat dealerships and marine equipment suppliers. A special placard is available for boats operating on the Great Lakes.

NOTICE

***IMPORTANT:** It is illegal to discharge waste from your marine sanitary device (toilet) into the water in most areas. It is your responsibility to be aware of and adhere to all local laws concerning waste discharge. Consult with the Coast Guard, local marina or your dealer for additional information.*

NOTICE

NOTE: Some states and localities have legal limits on speed, noise and trailer specifications. It is your responsibility to be aware of these laws and limits and to insure that your boat (and trailer) comply. Consult with your local Marine Patrol or local Coast Guard office.



B - 1 GENERAL

As the owner/operator of the boat, you are responsible for assuring that all required safety equipment is aboard. You should also consider supplying additional equipment as needed for your safety and that of your passengers. Check state and local regulations and call the US Coast Guard Boating Safety Hotline at 1-800-368-5647 for information about required safety equipment.

A. Required Safety Equipment

Most of the safety equipment required by federal regulations is provided as standard equipment. Personal Floatation Devices (life jackets) must fit the person wearing it. If local regulations require additional equipment, it must be approved by the US Coast Guard (USCG). Minimum requirements include the following:

- Personal Floatation Devices
- Visual Distress Signal
- Bell or Whistle
- Fire Extinguisher
- Navigation Lights

NOTICE

As the owner/operator of the boat, you are responsible for assuring that all required safety equipment is aboard and meets the boating regulations as prescribed by both federal and local authorities in your area.

B. Personal Floatation Devices (PFDs)

Federal regulations require that you have at least one Coast Guard approved personal floatation device (PFD) for each person in a recreational boat. You should not use your boat unless all PFDs are in serviceable condition, readily accessible, legibly marked with the Coast Guard approval number, of an appropriate size (within the weight range and chest size marked on the PFD) for each person aboard.

A PFD provides buoyancy to help keep your head above the water and to help you remain in a satisfactory position while in the water. Body weight and age should be considered when selecting a PFD. The buoyancy provided by the PFD should support the person's weight in the water.

The size of the PFD should be appropriate for the wearer. Body weight or chest size are common methods used to size PFDs. It is your responsibility to ensure that you have the proper number and types of PFDs on board and that your passengers know where and how to use them.

C. PFD Types

Five types of PFDs have been approved by the US Coast Guard. The PFDs are described as follows:

PFD Type 1, Wearable (Figure B-1) has the greatest required buoyancy. Its design allows for turning most unconscious persons in the water from face down position to a vertical or slightly backward, face-up position. It can greatly increase the chances of survival. Type 1 is most effective for all waters, especially offshore when rescue may be delayed. It is also the most effective in rough waters.



Figure B-1: Type I, Wearable

PFD Type II, Wearable (Figure B-2) turns its wearer in the same way as Type I, but not as effectively. The Type II does not turn as many persons under the same conditions as a Type I. You may prefer to use this PFD where there is a probability of quick rescue such as in areas where other people are commonly involved in water activities.



Figure B-2: Type II, Wearable

PFD Type III, Wearable (Figure B-3) allows the wearer to place themselves in a vertical or slightly backward position. It does not turn the wearer. It maintains the wearer in a vertical or slightly backward position and has no tendency to turn the wearer face down. It has the same buoyancy as a Type II PFD and may be appropriate in areas where other people are commonly involved in water activities.



Figure B-3: Type III, Wearable

PFD Type IV, Throwable (Figure B-4) is required in addition to the PFDs previously discussed. The most common Type IV PFD is a buoyant cushion or ring buoy. It is designed to be thrown to a person in the water, grasped and held by the user until he or she is rescued. A Type IV PFD should always be in serviceable condition and immediately available for use. Grasping this PFD may be difficult if the rescue is delayed or if the user is overcome by hypothermia (loss of body heat).



Figure B4: Type IV, Throwable

PFD Type V, Wearable (Figure B-5) when inflated, it provides buoyancy equivalent to Type I, II, or III PFDs. When it is deflated, however, it may not support some people.



Figure B-5: Type V, Wearable

D. PFD Pointers

The purpose of a PFD is to help save your life. If you want it to support you when you are in the water, it needs to fit, float, and be in good condition.

1. Try the PFD on and adjust it until it fits comfortably in and out of the water. Mark your PFD if you are the only wearer.
2. To make sure the PFD works, wear it in the water. This will show you how it works and give you confidence when you use it.

3. Teach children how to put a PFD on and allow them to try it in the water. That way, they know what the PFD is for and how it works. They will feel more comfortable with it if they suddenly find themselves in the water.
4. If the PFD is wet, allow it to dry thoroughly before storing it. Do not dry it in front of a radiator or heater. Store it in a well ventilated area.
5. Keep PFDs away from sharp objects which can tear the fabric or puncture the floatation pads.
6. For their own safety and the safety of others, all nonswimmers, poor swimmers, and small children should wear PFD's at all times, whether the boat is stationary or moving.
7. Check the PFD frequently to make sure that it is not torn, that floatation pads have no leaks, and that all seams and joints are securely sewn.
8. If a PFD contains kapok, the kapok fibers may become waterlogged and lose their buoyancy after the vinyl inserts are punctured. If the kapok becomes hard or if it is soaked with water, replace it. It may not work when you need it.

E. Fire Extinguisher

As the owner/operator of the boat, you are responsible for supplying a fire extinguisher approved by the US Coast Guard.

Hand-held portable extinguisher(s) should be mounted in a readily accessible location(s) away from the engine compartment. All persons aboard should know the location(s) and proper operation of the fire extinguisher(s).



Fire!

In case of fire do not open the engine compartment. Shut down engine(s), generator(s), and blower(s). Models with fixed fire suppression system will automatically discharge its entire contents. If using portable CO2 fire extinguisher continuously discharge entire contents.

NOTICE

Do not test fire extinguishers by squirting small amounts of the extinguishing compound. The fire extinguisher might not work when you really need it.

The Vista® models that measure 26 to less than 40 feet are considered Class 2 powerboats. All Class 2 powerboats are required to carry two (2) B-1 type approved hand portable fire extinguishers or one (1) B-2 type approved hand portable fire extinguisher. When a fixed fire extinguishing system is installed in machinery space(s), at least one (1) B-1 type approved hand portable fire extinguisher is required.

F. Fire Extinguisher System

An automatic FE241 agent fire extinguisher system is standard on the 318 Vista® models. The equipment utilized has been so chosen, and located, to provide sufficient volume and coverage of the entire engine compartment. While the system ensures excellent overall bilge fire protection, it does not eliminate the USCG requirement for hand-held fire extinguishers. Refer to the manufacturer’s literature included in the owner’s packet.

G. Visual Distress Signal Devices

Visual distress signal devices approved by the US Coast Guard are required on all recreational boats operating on coastal waters and to boats owned in the United States when they are operating on the high seas. Coastal waters include territorial seas and those waters directly connected to the Great Lakes and the territorial seas up to a point where the waters are less than two miles (3.2km) wide. Visual distress signal equipment may be of the pyrotechnic or non-pyrotechnic type. Regulations prohibit display of visual distress signals on the water under any circumstances except when assistance is required to prevent immediate or potential danger to persons on board a vessel.

The equipment must be approved by the US Coast Guard, be in serviceable condition, and be stowed in a readily accessible location. Equipment having a date for serviceable life must be within the specified usage date shown. Careful selection and proper stowage of visual distress equipment is very important if young children are aboard.

DAY USE ONLY	NIGHT USE ONLY	DAY AND NIGHT USE
Three orange smoke signals (one hand held and two floating) or one orange flag with black square and disk.	One S-O-S electric distress light.	Three flares of the hand held, meteor or parachute type.

Distress Signal Table

The minimum visual distress signals required in coastal waters for a Class 1 or Class 2 powerboat is the following:

One orange flag with black square-and disc (daytime); and an S-O-S electric light (nighttime); or three orange smoke signals, hand held or floating (daytime); or three red flares of hand held, meteor, or parachute type (daytime/nighttime).

NOTICE

No single signaling device is appropriate for all purposes. Consider keeping various types of equipment on board.

H. Sound Signaling Devices

Class 1 and Class 2 powerboats are required to carry a hand, mouth or power operated horn or whistle. It must produce a blast of two-second duration and audible at a distance of at least one-half (1/2) mile. The 318 Vista® model is equipped with a dual trumpet horn which meets this requirement. See Figure B-6.

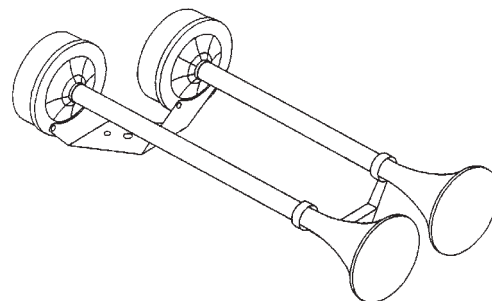

Figure B-6: Dual Trumpet Horn

The following are standard whistle signals:

- One Prolonged Blast = Warning Signal
- One Short Blast = Pass on my Port Side
- Two Short Blasts.= Pass on my Starboard Side
- Three Short Blasts = Engines in Reverse
- Five or More Blasts = Danger Signal

I. Navigation Lights

Navigation lights are intended to keep other vessels informed of your presence and course. If you are out on the water between sunset and sunrise, you are required to display appropriate navigation lights.

J. Additional Recommended Equipment

Four Winns recommends that you acquire additional equipment for safe, enjoyable cruising. This list, which is not all inclusive, includes items you should consider acquiring.

Basic Gear

Flashlight	Spare batteries	Tow line
Oar, paddle	Mooring lines	Compass
Dock fenders	Distress signals	First aid kit
Boat hook	VHF radio	EPIRB*
Sunscreen	Extra warm clothing	Charts
Second anchor & line		
Dewatering device (pump or bailer)		
Emergency supply of drinking water and food.		
*Emergency Position Indicating Radio Beacon		

Tools

Spark plug wrench	Hammer	Screwdriver
Jackknife	Pliers	
Electrical tape	Duct tape	
Adjustable wrench	Lubricating oil	Prop wrench

Spare Parts

Extra bulbs	Spare prop	Extra fuses
Extra drain plug	Spark plugs	Spare wire
Extra prop nut/washer		

Gear For Extended Cruises

Foul weather gear	Parallel rulers	Dividers
Global Positioning System navigation equipment		

B - 2 CARBON MONOXIDE



Carbon Monoxide!

Carbon monoxide (CO) can be harmful or fatal if inhaled. Brain damage or death can result from prolonged exposure to carbon monoxide. Keep exhaust outlets clear of blockage. Provide adequate ventilation. Open hatches, doors, windows and vents to insure adequate ventilation. Close engine compartment doors and hatches when engine or generator is running. Avoid operating the boat for extended periods of time at idle speed, and be sensitive to weather conditions that may prevent CO from dissipating into the air. Do not stand or swim near engine or generator exhausts when engines are running.

Carbon monoxide accumulation is affected by many variables (e.g., boat geometry, hatch, window and door opening, ventilation openings, proximity to other structures, swim platforms, canvas enclosures, location of exhaust outlets, vessel attitude, wind direction, vessel speed, boat systems maintenance, etc.) The technical information included in this section is to inform the boat owner of possible cause and effects of carbon monoxide exposure. This information has been reprinted with permission from the American Boat and Yacht Council's (ABYC) technical information report: "[Educational Information About Carbon Monoxide](#)". This information pertains to all gasoline powered boats manufactured by Four Winns.

NOTICE

The boat owner should be aware that other factors may contribute to carbon monoxide accumulation. The most common ones are listed in this section. If a person is exhibiting carbon monoxide-type symptoms (Refer to B-2E Symptoms), be sure to take the necessary precautions as prescribed later in this section.

NOTICE

Boats fueled by diesel have limited carbon monoxide present in the exhaust in comparison to gasoline engine exhaust. However, the boat owner should still be aware of the causes and effects of carbon monoxide which may occur in different boating situations.

A. Properties and Characteristics of Carbon Monoxide

1. Carbon Monoxide is a colorless, odorless and tasteless gas. It is commonly referred to as CO.
2. Its weight is about the same as air so it cannot be expected to rise or fall like some other gases, but will distribute itself throughout the space.

NOTICE

DO NOT rely on the use of smell or sight of other gases to detect CO, because it diffuses in the air much more rapidly than easily detectable vapors (i.e. visible and aromatic vapors).

B. What Makes Carbon Monoxide

Any time a material containing carbon burns such as gasoline, natural gas, oil, propane, coal, or wood, CO is produced.

Common sources of carbon monoxide are:

1. Internal combustion engines such as:
 - a. Propulsion engines
 - b. Generators
2. Open flame devices such as:
 - a. Cooking ranges
 - b. Central heating plants
 - c. Space heaters
 - d. Water heaters
 - e. Fireplaces
 - f. Charcoal grills

C. How a Person is Affected by Carbon Monoxide

Carbon monoxide is absorbed by the lungs and reacts with blood hemoglobin to form carboxyhemoglobin, which reduces the oxygen carrying capacity of the blood. The result is a lack of oxygen for the tissues with the subsequent tissue death and, if exposure is prolonged, death of the individual.

D. Effects of Carbon Monoxide

Carbon monoxide in high concentrations can be fatal in a matter of minutes. Lower concentrations must not be ignored because the effects of exposure to CO are cumulative and can be just as lethal.

Certain health related problems and age will increase the effects of CO. People who smoke or are exposed to high concentrations of cigarette smoke, consume alcohol or have lung disorders or heart problems, are particularly susceptible to an increase in the effects from CO. However, all occupants' health should be considered. Physical exertion accelerates the rate at which the blood absorbs CO.

E. Symptoms

One or more of the following symptoms can signal the adverse effect of CO accumulation:

1. Watering and itchy eyes
2. Flushed appearance
3. Throbbing temples
4. Inattentiveness
5. Inability to think coherently
6. Loss of physical coordination
7. Ringing in the ears
8. Tightness across the chest
9. Headache
10. Drowsiness
11. Incoherence
12. Slurred speech
13. Nausea
14. Dizziness
15. Fatigue
16. Vomiting
17. Collapse
18. Convulsions

NOTICE

The order of the above list is generally the sequence of appearance of symptoms. However, the order of appearance may change for different people.

NOTICE

The symptoms of Carbon monoxide poisoning may easily be mistaken for seasickness.

F. Treatment (Evaluate, Ventilate, Evacuate, Investigate, Take Corrective Action)

1. Evaluate the situation and ventilate the area if possible.
2. Evacuate the area and move affected person(s) to a fresh air environment.
3. Observe the victim(s).

- Administer oxygen if available.
- Contact medical help. If the victim is not breathing, perform rescue breathing or approved cardiopulmonary resuscitation (CPR), as appropriate, until medical help arrives and takes over.

NOTICE

Prompt action can make the difference between life and death.

- Investigate source of CO and take corrective action.

G. Inspection

Look and listen for leaks in the exhaust systems of both the generator and propulsion engine(s). Look for discoloration around joints in the system (water leaks, carbon, stains, etc.).

- Make sure all exhaust clamps are in place and secured.
- Make sure ventilation systems work and are not obstructed or restricted.
- Make sure gaps around the engine room plumbing and cableways and exhaust system doors, hatches, and access panels are minimized to reduce the opportunity for CO to enter the accommodation space(s).

H. Operation

Cold Start vs. Warm Start: CO production is greater while the combustion chamber surfaces and gas passages are cold versus when they are warm. A boat operator should:

- Pay attention to ventilating the boat.
- Orient the boat so it will allow the maximum dissipation of CO.
- Minimize the time spent on getting underway.
- In order to minimize CO buildup, do not warm up or run propulsion engine(s) for extended periods while the vessel is stationary.

WARNING

The following are examples of possible situations where carbon monoxide can accumulate within your boat while docked, anchored, or underway. Become familiar with these examples and their precautions to prevent dangerous accidents or death.

I. Boathouses, Sea Walls and Confined Spaces

A boat operator should be aware that dangerous concentrations of CO can accumulate when a boat, generator or other engine operated device is operated while the boat is moored in a confined area such as:

- Boathouses,
- Proximity to sea walls, or
- Proximity to other boats.

Keep engine room hatches and doors closed when operating engines, including the generator.

Pay attention to prevailing conditions and provide for ventilation to induce fresh air and minimize exhaust re-entry. Orient the boat for maximum dissipation of the exhaust. **DO NOT** run the boat or boat equipment for extended periods under these conditions. See Figure B-7.

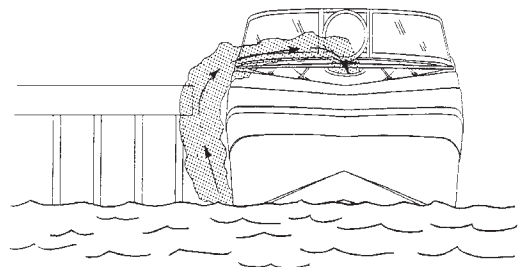

Figure B-7: The effect of sea walls and other confined spaces.

Be aware that cockpit and deck drains can be a source of CO ingress into boats, especially boats with cockpit or decks enclosed with canvas or permanent boat structures.

J. The Effect of Boats Moored Alongside

A boat operator should be aware that carbon monoxide is emitted from any boat's exhaust. The operation, mooring, and anchoring in an area containing other boats may be in an atmosphere containing CO not of the operator's making. An operator likewise needs to be aware of the effect of their boat on other boats in the area. Of prime concern is the operation of an auxiliary generator where boats are moored alongside each other. Be aware of the effect your exhaust may have on other boats and be aware that the operation of other boats' equipment may affect the carbon monoxide concentration on your boat. See Figure B-8.

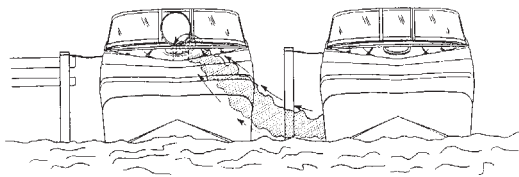

Figure B-8: The effect of boats moored along side.

K. Backdrafting (Station Wagon Effect)

Backdrafting or the "station wagon effect" is caused by air movement over or around a boat creating a low pressure area or suction area around the stern that can increase CO level on the boat. Backdrafting can be affected by relative wind direction, boat speed, and boat trim angle. See Figure B-9 Backdrafting - Airflows Over Boat and Behind Transom".

Under certain speed and operating conditions the low pressure area may form in other regions and permit carbon monoxide to enter the hull through openings that are not on the back of the boat. Boat factors which may affect CO concentration:

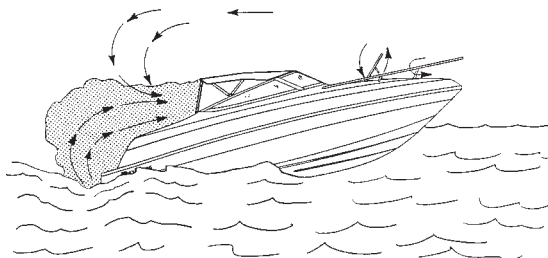

Figure B-9: Backdrafting - Air flows over boat and behind transom.

1. Intentional or unintentional excessive trim angle causing high bow angle. See Figure B-10.
2. Excessive or unequally distributed weight.

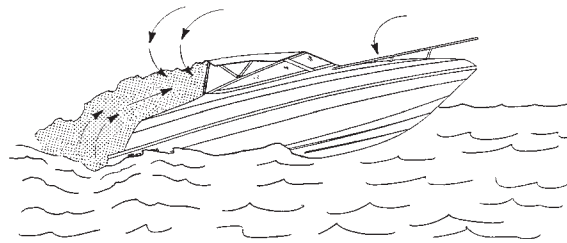

Figure B-10: Inefficient trim angles.

3. Canvas Configurations -Under various conditions, adding or removing canvas may raise or lower CO levels. See Figures B-9, B-10 & B-12.



WARNING

Exhaust Fumes!

Hull exhaust from your boat can cause excessive accumulation of poisonous carbon monoxide gas within cockpit areas when using protective weather coverings (while underway or while stationary). Provide adequate ventilation when the canvas top, side curtains and/or back (aft) curtains are in their closed protective positions.

4. Opening and closing ports, hatches, doors, and windows may raise or lower CO levels on board a boat. When airflow is moving forward inside the boat, CO may be entering the boat. See Figures B-11 and B-12.

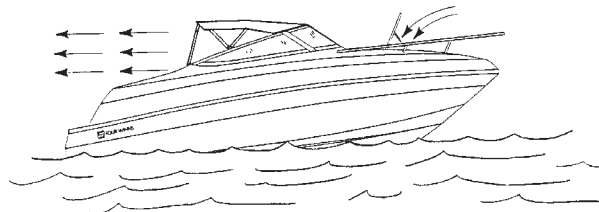

Figure B-11: Desired air flow through the boat.

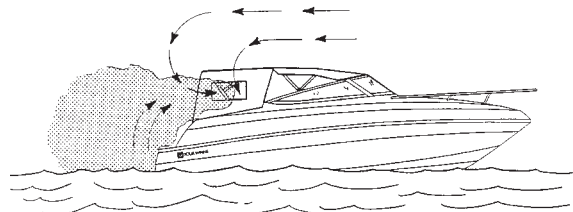

Figure B-12: The effect of canvas configurations.

5. Operating a boat at slow speeds with a following wind should be avoided. Consider changing direction, adjusting speed, or both. See Figures B-13.

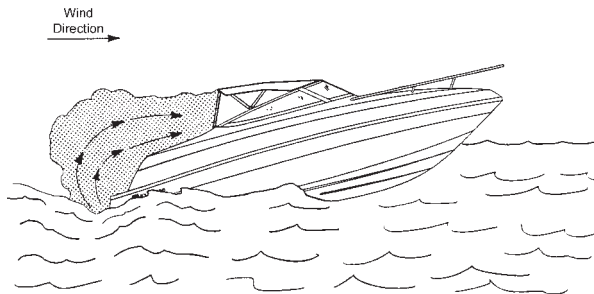

Figure B-13: Operating at Slow Speed with Following Wind

6. Be aware that cockpit and deck drains can be a source of CO ingress into boats, especially boats with cockpit or decks enclosed with canvas or permanent boat structures.

L. Accumulation of Exhaust Gases-Swim Platform

When the propulsion engine(s) or generator is running, CO is produced and may remain in the vicinity of the exhaust outlet (including underwater exhaust outlets such as sterndrives and outboards). Refer to Figure B-14.

1. Do not occupy aft lounging area(s) or swim platform.
2. Do not swim under or around swim platform.
3. Do not swim in the vicinity of the exhaust outlet.

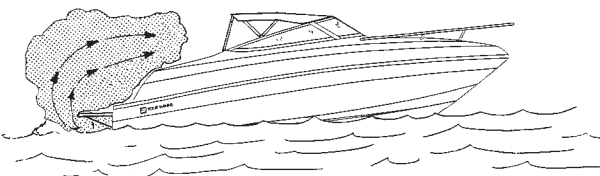

Figure B-14: Exhaust Gas Accumulation at Swim Platform

M. Dangerous Activity - "Teak Surfing"/"Dragging"

Do not sit on, occupy or hang on any stern appendages (e.g., swim platforms, boarding ladders, etc.) while underway. Do not body surf, commonly known as "teak surfing" or "dragging", etc. in the wake of the boat. Do not tow persons in close proximity to the stern of the boat. See Figure B-15.

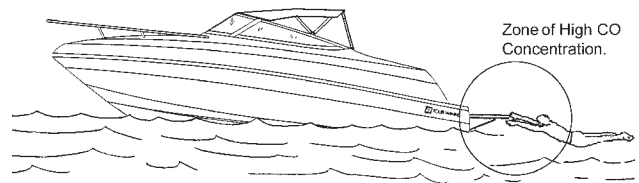

Figure B-15: Exhaust Gas Accumulation - Dangerous Activity

N. Cabin Appliances

Boats having fuel burning appliances in accommodation areas should be provided with adequate ventilation and the appliance should be maintained to function properly.

O. Air Conditioning

Lack of system maintenance may cause CO to be brought into the air-conditioned spaces by the air conditioner. Please refer to the air conditioner manufacturer's literature for additional information.

P. Ventilation of Accommodation (Occupied) Spaces

Accommodation spaces need to be ventilated to introduce fresh air into the spaces. Ventilation methods (e.g. windows, hatches, doors, and blowers) used to accomplish this may, under certain conditions, bring hazardous levels of CO into the occupied spaces. Care should be taken to be aware of all prevailing conditions when using these ventilating methods.

Q. Running of Engines in Idle

Engines running in idle exhaust carbon monoxide that can accumulate near the hull of the boat. Do not stand or swim near the engine exhaust or outdrive when engines are idling or generator is running.

R. Altitude and Sea Conditions

Operation at altitudes greater than 5,000 feet contributes to inefficient engine performance and may require adjustments to the ignition systems, fuel systems, or changing the propeller's size or gear ratio.

1. Failure to make adjustments to ignition systems and/or fuel systems for altitude conditions may cause an increase in CO production.
2. Reduced power resulting from increased altitude may require adjustments to propeller size.

3. Heavy sea or out of trim conditions tend to load engines resulting in reduced performance and thereby increasing their CO production.

S. Portable Generator Sets



Never use a portable generator on a boat.

Gasoline powered portable generators are available in the marine market place and are not an option available through Four Winns. Portable generators will produce CO. These sets discharge their exhaust products in locations which can lead to an increase in the accumulation of carbon monoxide in the accommodation (occupied) space. **Do not use gasoline powered portable generators on Four Winns® boats.**

T. Maintenance - Engine Performance

Efficient engine performance is vital to minimizing CO production. The following items are those considered to have the greatest effect on increased CO production:

1. Fuel Systems - Fuel that is contaminated, stale or incorrect octane number
2. Carburetors/Injectors
 - a. Dirty or clogged flame arrester
 - b. Malfunctioning automatic choke plate or faulty adjustment of manual choke plate
 - c. Worn float needle valve and seat
 - d. High float level
 - e. Incorrect idle mixture adjustment
 - f. Dirty or worn injectors
3. Ignition System
 - a. Fouled or worn spark plug.
 - b. Worn points or incorrect gap on points
 - c. Shorted or opened circuit high tension spark plug cables
 - d. Incorrect ignition timing.

4. General

- a. Worn piston rings and valves
- b. Engine temperature - Cold running engines increase CO production. Engine cooling water system design and selection of thermostat(s) are primary considerations affecting engine operating temperature. Generally, an engine produces less CO if it operates at a relatively high temperature within manufacturer's specifications.
- c. Exhaust Back-Pressure - Certain alterations to the exhaust system may increase engine exhaust back pressure and CO production.
- d. Restricted engine room or compartment ventilation

U. Maintenance - External Conditions

External conditions that contribute to inefficient engine performance can include:

1. Fouled hull bottom
2. Damaged and fouled running gear (i.e., shaft, strut propeller, rudder and trim tabs)
3. Incorrect selection of propeller size

V. Maintenance - Exhaust System Integrity

Gas tight integrity of exhaust systems must be maintained to insure that leakage of CO within the boat does not occur. Disassembly may be required to carry out a thorough inspection. Repair or replace components as indicated. Inspect the following:

1. Gaskets at cylinder head connection
2. Casting and pipe fittings in the dry section
3. All joints
4. Hoses
5. Clamps
6. Mufflers and their drain plugs
7. Thru-hull fittings
8. Hangers and other supports

W. Maintenance - Ventilation Systems

Boats are equipped with ventilation systems to eliminate gasoline vapors. Blowers and fans may also be provided for ventilation and to mitigate the migration of CO into occupied compartments. Attention should be paid to the following:

1. Keeping ventilation intakes clear of debris
2. Replacing damaged hardware
3. Maintaining the integrity of the ducting material and its connections
4. Ensuring that position of ducting intake is not obstructed or restricted, collapsed, kinked, or crushed.
5. Eliminating sags in ducting that can form a water trap
6. Checking hangers and other supports
7. Ensuring blower/fan is operational
8. Ensuring that airflow is present at discharge
9. Inspecting wiring to equipment

X. Maintenance - Bulkhead and Deck Integrity

1. Seal all visible openings (e.g., cracks, crevices, holes, including openings around wiring and piping runs) in bulkheads and decks that separate machinery compartments from occupied compartments. These openings can permit migration of CO vapors.
2. Check gaskets and sealing surfaces on hatches, doors, and access panels.

Y. Maintenance - Air Conditioning Systems

These systems can be a source of CO ingress and migration of CO vapors.

1. Keep grilles and filters clean.
2. Seal bulkhead voids and openings at wiring and piping runs in return air ducting, plenums, and air handling equipment enclosures, especially those adjacent to machinery compartment bulkheads.

3. Check that water traps and condensate drains are present. These may be in the form of a double loop in the drain line or prefabricated p-traps. Any drain that discharges below the waterline when the boat is underway is sealed, by virtue of its design, against CO intrusion.

Z. Maintenance - Liquid Drains

Sink, shower and condensate drains can be a source of CO ingress. Ensure that water traps are present and contain fluid. These traps may be in the form of a double loop in the drain line or prefabricated p-traps. Any drain that terminates below the waterline is, by virtue of its design, sealed against CO intrusion. Some drains that are below the waterline when boat is underway will be above the waterline when the boat is at rest. The location of drains, relative to the waterline, can be affected by the dynamics of boat motion (i.e., underway or at rest).

AA. Carbon Monoxide Detection Systems

Four Winns has included two CO detectors as a standard feature. One of the CO detectors is located in the forward V-berth and the other is located in the aft/mid cabin. Check systems and maintain in accordance with the manufacturer's instructions.



CO monitors should be professionally installed and calibrated. Failure to do so may result in the improper function of the CO detector.



Never disarm a CO detector. If a CO detector alarms, immediately ventilate the area and check passengers for symptoms of CO intoxication. See your Four Winns dealer for assistance in diagnosing the cause for the alarm.

NOTICE

For information on CO Detection Systems, see American Boat and Yacht Council (ABYC Manual) Section A-24, "Carbon Monoxide Detectors".

Even with the best of boat design and construction along with the utmost care in inspection, operation, and maintenance of boat systems, hazardous levels

of CO may still be present in accommodation spaces and exterior areas under certain conditions. Vigilant observation of passengers for CO sickness symptoms should be supplemented by a marine CO detection device in the accommodation space.

 **WARNING**

A CO detector is not a gas/fuel vapor detector. Gas/fuel vapor detectors do not monitor the buildup of carbon monoxide in an enclosed area. For further information on the design, construction, and testing of boats in consideration of carbon monoxide, see ABYC TH-23.

NOTICE

Detection devices should meet the requirements of ABYC A-24 "Carbon Monoxide Detection Systems on Boats".

B - 3 SAFE BOATING PRACTICES**NOTICE**

YOU are responsible for your own safety, the safety of your passengers, and the safety of fellow boaters.

A. Drugs and Alcohol **WARNING**

Alcohol consumption and boating do not mix! Operating under the influence endangers the lives of passengers and other boaters. Federal laws prohibit operating a boat under the influence of alcohol or drugs.

Do not use drugs or drink alcohol while operating a boat. Like driving a car, driving a boat requires sober, attentive care. Operating a boat while intoxicated or under the influence of drugs is not only dangerous, but it is also a Federal offense carrying a significant penalty. These laws are vigorously enforced. The use of drugs and alcohol, singly or in combination, decreases reaction time, impedes judgement, impairs vision, and inhibits your ability to operate a boat.

B. Safe Operation

Safe operation means that you do not misuse your boat nor do you allow your passengers to do so. Safe operation means using good judgement at all times. It includes, without limitation, the following actions:

- Observe all safety signs and warnings both inside the boat and in the immediate boating area.
- Become familiar with, and adhere to, the "Rules of the Road".
- Maintain boat speed at or below the legal limits. Avoid excessive speed or speeds not appropriate for operating conditions.
- Be sure at least one other passenger is familiar with the operation and the safety aspects of the boat in case of an emergency.
- Load the boat within the limits listed on the capacity plate. Balance loads bow and stern and port to starboard.
- Do not use the boat in bad weather or sea conditions beyond the skill or experience of the operator or the comfortable capability of the boat or passengers.
- Make sure the passengers and gear do not obstruct the operator's view or impede his ability to move.
- Do not exceed the maximum engine power rating stated on the certification plate located inside the boat.

C. Passenger Safety

Before getting underway, show all passengers where emergency and safety equipment is stowed, and explain how to use it. Everyone aboard should wear rubber-soled shoes which resist slipping on wet surfaces. While underway, passengers should remain seated inside the deck rails and gates. Do not allow passengers to drag their feet or hands in the water. Always use handholds and other safety hardware to prevent falls. All nonswimmers, poor swimmers and small children should wear PFDs at all times.

D. Propeller



Personal Injury!

Do not allow anyone near a propeller, even when the engine is off. Propeller blades can be sharp and continue to turn even after the engine is shut off. Do not allow anyone near the propeller when the throttle is in neutral position. Accidentally engaging the shift can result in a serious injury or death. (See actual ladder warning labels and helm boarding ladder warning label below).



Never approach or use ladder when motor is running. Severe injury or death will result from contact with rotating propeller.

Ladder Warning Label



Shut off motor when near swimmers. Severe injury or death will result from contact with rotating propeller.

Helm Boarding Ladder Warning Label



When pulling skiers do not turn on the engine until you are at least a boat length away from the person in the water. When approaching a downed skier, turn off the engine at least one boat length away before reaching the skier in the water.

E. First Aid

As a boater, you should be familiar with the basic first aid procedures that may be needed while you are out far from help. Fish hook accidents or minor cuts and abrasions may be the most serious mishaps on board a boat but you should also learn the proper procedures and be ready to deal with the truly serious problems like mouth-to-mouth resuscitation, excessive bleeding, hypothermia, and burns. First aid literature and courses are available through most Red Cross chapters.

F. Operation By Minors

Minors should always be supervised by an adult whenever operating a boat. Many states have laws regarding the minimum age and licensing requirements of minors. Be sure to check local laws or contact the state boating authorities for information.

G. “Rules of the Road”

As a responsible boater, you must comply with the “Rules of the Road,” the marine traffic laws enforced by the US Coast Guard. Navigating a boat is much the same as driving an automobile. Operating either one responsibly means complying with a set of rules intended to prevent accidents. Just as you assume other car drivers know what they are doing, other boaters assume you know what you are doing. Information regarding navigational rules and the “Rules of the Road” are discussed in further detail in C-1 & C-2 of the next section.

H. Voluntary Inspections

State boating officials in many states or the US Coast Guard Auxiliaries offer courtesy inspections to check out your craft. They will check for compliance with safety standards and required safety equipment. You may voluntarily consent to one of these inspections, and you are allowed to make corrections without prosecution. Check with the appropriate state agency or the Coast Guard Auxiliary for details.

I. Safe Boating Courses

The local US Coast Guard Auxiliary and the US Power Squadrons offer comprehensive safe boating classes several times a year. You may contact the Boat/US Foundation at 1-800-336-BOAT (2628) or, in Virginia, 1-800-245-BOAT (2628) for a course scheduled in your area. Also contact the US Coast Guard Auxiliary or Power Squadron Flotilla for the time and place of their next scheduled class.

B - 4 WATER SPORTS



PERSONAL INJURY

Four Winns® boats are not designed for and should not be used for pulling parasails, kites, gliders or any device which can become airborne. Use boat only for appropriate water sports. (See Preface for actual warning label).

Water skiing, wakeboarding, kneeboarding, or riding a towed, inflatable apparatus are some of the more popular water sports. Taking part in any water sport requires increased safety awareness by the participant and the boat operator. If you have never pulled someone behind your boat before, it is a good idea to spend some hours as an observer, working with and learning from an experienced driver. It is also important to be aware of the skill and experience of the person being pulled. Always have a second person on board to observe the person in the water so the driver can concentrate on operating the boat.

A. Water Sport Guidelines

Everyone participating in a water sport should observe these guidelines:

1. Allow only capable swimmers to take part in any water sport.
2. Always wear a personal floatation device (PFD) approved by the US Coast Guard. Wearing a properly designed PFD helps a stunned or unconscious person stay afloat.
3. Be considerate of others with whom you share the water.
4. Give immediate attention to a person who has fallen. He or she is vulnerable in the water alone and may not be seen by other boaters.
5. Approach a person in the water from the lee side (opposite the direction of the wind). **Turn off the motor at least a boat length from the person.**
6. Turn engine off and anchor before swimming.
7. Always participate in water sports in safe areas. Stay away from other boats, beaches, restricted areas, swimmers and heavily traveled waterways.

8. Swim only in areas designated as safe for swimming. These are usually marked with a swim area buoy (see Figure B-15). Do not swim alone or at night.



Figure B-15: Swim Area Buoy



Rotating Propeller!

Rotating propeller can cut or sever causing serious injury or death. Shut engine off and remove ignition key when anyone is swimming nearby. (See Section B-3D).

9. Do not allow anyone near the propeller(s), even when the engine is off. Propeller blades are sharp and can continue to turn even after the engine is off. Stay at least 150 feet away from areas marked by diver down float. See Figure B-16.



Figure B-16: Diver Down Float

10. Do not drive the boat directly behind a water skier. At 25 miles per hour, the boat will overtake a fallen skier who was 200 feet in front in about 5 seconds.

B. Water Skiing/Wakeboarding/Kneeboarding

The popular sport of water skiing has brought a special set of safety precautions to observe in boating. The following guides help prevent accidents while water skiing.

1. Water ski only in safe areas, away from other boats and swimmers, out of channels, and in water free of underwater obstructions.

2. Allow no one who can not swim to water ski. Skiers must wear a USCG approved floatation device. A Type III water-ski vest is an approved and practical PFD.
3. Have a second person aboard to observe the skier and inform the driver about the skier's hand signals (Figure B-17). The driver must give full attention to operating the boat and the waters ahead.
4. Give immediate attention to a fallen skier. Be careful not to swamp the boat while taking the skier on board.
5. Always participate in water sports in safe areas. Stay away from other boats, beaches, swimmers, and heavily traveled waterways.
6. Be considerate of others with whom you share the water.
7. Give immediate attention to a person who has fallen. He or she is vulnerable in the water alone and may not be seen by other boaters.
8. Approach a person in the water from the lee side (opposite the direction of the wind). Stop the motor at least a boat length from the person.
9. Turn off engine and anchor your boat before swimming.

WARNING

Rotating Propeller!

Rotating propeller can cut or sever causing serious injury or death. Switch engine off before skiers enter the water and before taking skiers aboard. Do not leave engine running in neutral. Accidentally engaging shift can seriously injure skier.

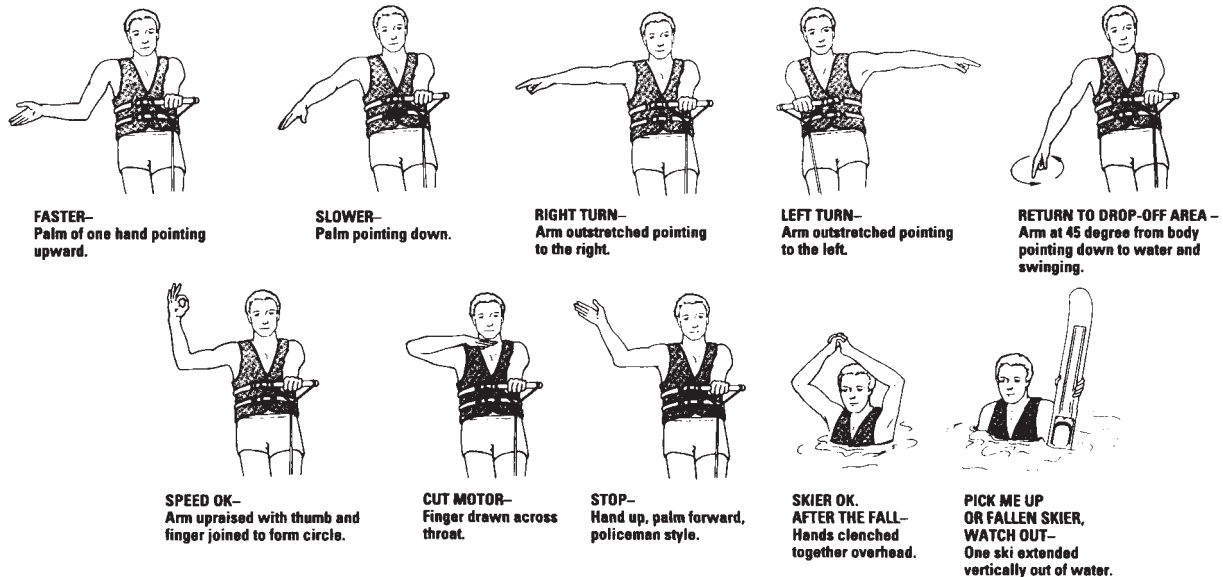

Figure B-17: Skier's Hand Signals

C - 1 GENERAL

Basic rules of seamanship, general information about navigational aids, and sources for additional reading and boater education are presented in this portion of your owner's manual.

A. Boating Regulations

The US Coast Guard is the authority of the waterways. State boating regulations are enforced by local authorities. Your boat is subject to the marine traffic laws known as "Rules of the Road," which are enforced by the US Coast Guard. You are subject to marine traffic laws and "Rules of the Road" for both federal and state waterways; you must stop if signaled to do so by enforcement officers, and permit them to board if asked. The "Navigational Rules, International-Inland Rules of the Road" can be obtained from the US Coast Guard website at www.uscgoating.org.

Many pamphlets prepared by the US Coast Guard are available. They explain signal lights, buoys, safety, international and inland regulations and other information which goes beyond the scope of this manual. "Aids to Navigation" (US Coast Guard pamphlet #123) explains the significance of various lights and buoys. Because of proposed alterations to buoys and markers, contact the US Coast Guard or visit their website to stay informed of changes. Other pamphlets, including the "Boating Safety Training Manual" and "Federal Requirements For Recreational Boats," are also available from the US Coast Guard.

NOTICE

The spoken word "MAYDAY" is the international signal for distress. "MAYDAY" should NEVER be used unless there is grave or imminent danger, and you are in need of immediate assistance.

B. Rules of Seamanship

1. Right-of-way

In general, boats with less maneuverability have right-of-way over a more agile craft. You must stay out of the way of the following vessels:

A vessel not under command or aground.	These vessels have no maneuverability.
A vessel restricted in its maneuverability.	These vessels are performing work which limits their maneuverability such as surveying, dredging, laying pipe or cable, servicing navigational markers among others.
A vessel engaged in fishing.	These include boats fishing with lines, trawl or nets; but not trolling lines.
Sailboats	Sailboats have the right-of-way over power boats; however, if a sailboat is using a propeller to move forward, it is considered a power boat even if its sails are up.

2. Meeting Head-On

When two boats meet head-on neither boat has right-of-way. Both boats should decrease speed and pass; port to port. However, if both boats are on the left side of a channel, each vessel should sound two short horn blasts and pass to starboard to starboard. See Figure C-1.

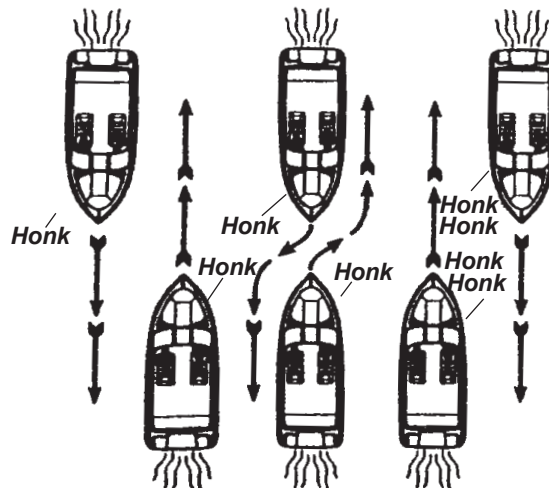

Figure C-1: Meeting Head-On

3. Crossing Situations

In a crossing situation, the boat on the right from the 12-4 o'clock position has the right-of-way. It must hold course and speed. The boat without the right-of-way must keep clear and pass to the stern. See Figure C-2.

Stand-on (Privileged) Vessel holds course and speed.

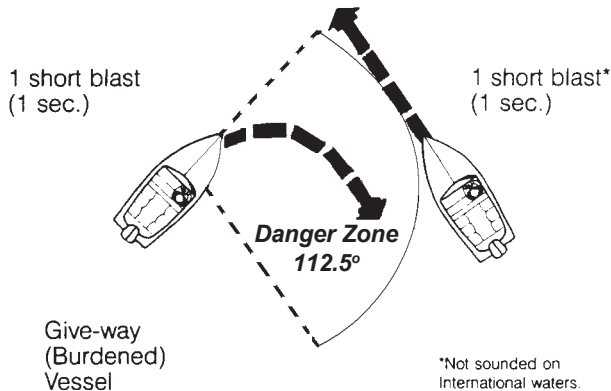

Figure C-2: Crossing Situation

4. Overtaking

The boat overtaking the one ahead must yield the right-of-way to the boat being passed. The overtaking boat must make necessary adjustments to keep out of its path. The boat being passed should hold its course and speed. See Figure C-3.

Inland Rules	Stand-on (Privileged) Vessel Being Overtaken	Inland Rules
"I want to pass you on your port side."		"I want to pass you on your starboard side."
2 short blasts (1 sec.)		1 short blast (1 sec.)
"Proceed"		"Proceed"
2 short blasts (1 sec.)		1 short blast (1 sec.)
International Rules		International Rules
"I am altering my course to port."		"I am altering my course to starboard."
2 short blasts (1 sec.)		1 short blast (1 sec.)
International Rules in Narrow Channels		International Rules in Narrow Channels
"I intend to pass you on your port side."		"I intend to pass you on your starboard side."
2 prolonged blasts (4-6 sec.)		2 prolonged blasts (4-6 sec.)
2 short blasts (1 sec.)		1 short blast (1 sec.)
"Proceed."		"Proceed."
1 prolonged, 1 short		1 prolonged, 1 short
1 prolonged, 1 short		1 prolonged, 1 short blast

Figure C-3: Overtaking

5. The General Prudential Rule

The general prudential rule regarding right-of-way is that if a collision appears unavoidable, neither boat has right-of-way. As prescribed in the "Rules of the Road", both boats must act to avoid collision.

6. Night Running

Boats operating between sunset and sunrise (hours vary by state), or in conditions of reduced visibility, must use navigational lights. Nighttime operation, especially during bad weather or fog, can be dangerous. All "Rules of the Road" apply at night, but it is best to slow down and stay clear of all boats regardless of who has right-of-way.

To see more easily at night, avoid bright lights when possible. Also, it is helpful to have a passenger keep watch for other boats, water hazards, and navigational aids.

To determine the size, speed and direction of other vessels at night, you should use running lights. A green light indicates the starboard side, and the red light indicates the port side. Generally, if you see a green light, you have the right-of-way; if you see a red light, give way to the other vessel. See Figure C-4.

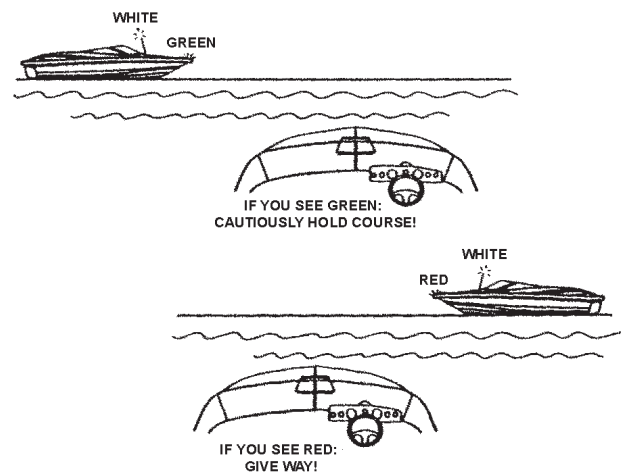

Figure C-4: Night Running

7. Whistle Signal

Out on the water, whistle signals are commonly used. Although using a whistle signal is not necessary every time a boat is nearby, operators must signal their intentions when necessary to avoid potentially confusing or hazardous situations. Use whistle blasts early enough to be noticed and understood by other boaters.

It is customary for the privileged boat to signal first and the yielding boat to return the same signal to acknowledge she understands and will comply. Use the danger signal (five or more short and rapid

blasts) if intent is not clear. A short blast is one or two seconds long. A long blast is 4 to 6 seconds long. The Navigational Aids Chart at the end of this section lists the meanings of the various whistle signals.

C - 2 NAVIGATIONAL AIDS

Aids to navigation (ATONS) help you to travel safely on the water. They help you get from one place to another and are most helpful if you have a nautical chart. A navigational aids chart is at the end of this section.



DANGER

NEVER tie your vessel to an ATON. It is illegal because it blocks the ATON from view of other boaters. Decreased visibility can contribute to a serious accident which may result in property damage, personal injury, or death.

There are two ATON systems. The system used on federal waters is known as the International Association of Lighthouse Authorities System B (IALA-B). The Coast Guard maintains this system. The second system is the Uniform State Waterway Marking System (USWMS). This system is maintained by state authorities.

A. International Association of Lighthouse Authorities System B (IALA-B)

IALA-B uses four types of ATONS. This section discusses the two most common markers: lateral markers and safe water markers. Other federal markers include special markers and isolated danger markers. The Navigational Aids Chart at the end of this section shows these aids.

B. Lateral Markers

Lateral markers indicate the sides of navigable channels. They consist of lighted can or nun buoys and daymarks. Each has a number and is either red or green. The numbers on the green markers are odd. Red markers have even numbers.

Buoys are red or green floating ATONS. If lighted, they have either red or green lights. Unlighted green buoys, called cans, look like cylinders. Unlighted red nun buoys have a cone shaped top with their points cut off. Do not pass too close to a buoy. You may foul the propeller in its chain.

NOTICE

Buoys are anchored floating objects and may not always be in exactly the same position.

Daymarks are red or green boards with numbers. They are on posts or groups of pilings tied together and called dolphins. Daymarks and their supports are daybeacons. Daybeacons may or may not have lights. If a red or green daybeacon has a light, it is the same color as the marker-red or green. Red daymarks are triangular and have even numbers. Green daymarks are square and have odd numbers.

Red Right Returning is a basic rule to assist you in using lateral markers. When you are returning from seaward, keep red markers on the starboard (right) side when you pass them. Keep green markers to the port side.

Returning from seaward is very clear if you have been on the ocean. You are returning to port. By agreement, going upstream on a navigational river is returning from seaward. The outlet ends of the Great Lakes are also the seaward ends. Traveling from a large body of water to a smaller one is considered returning from seaward.

C. Safe Water Markers

Safe water markers have vertical red and white stripes and mark the center of navigable channels and fairways. Safe water markers included both lighted and unlighted buoys and daymarks. If a marker is lighted, the light is white and flashes the letter "A" is Morse Code.

Preferred Channel markers have horizontal red and green bands. If lighted, the color of the light is the same as the top of the band. They show the preferred channel for you to use at a junction point. Be sure to notice the color of the top of the band, and treat it as any other marker you would of that color. If the band is red and you are returning from seaward, keep the marker to the right.

Most lights on markers flash on and off. Others such as lights on aids with no lateral significance are fixed. They stay on all night. ATON lights flash in regular patterns. For example, they may flash every three seconds, or in groups such as two flashes and a pause. There are a number of flashing patterns, which help you identify the light at night. To identify

a light, note its color and pattern or timing of flashes, and compare it to your chart to find its location.

D. The Uniform State Waterway Marking System

This section discusses three kinds of markers in this system: Regulatory, Informational, and Lateral.

Regulatory markers in this system are either signs or buoys. Signs are square with orange borders. Regulatory buoys are white and shaped like cylinders. They have horizontal orange bands near their tops and just above the water's surface. An orange circle on a marker means a controlled area. A message such as "No Wake, Idle Speed, No Skiing, or 5 M.P.H." may appear on a marker. An orange diamond means danger. If a diamond has an orange cross inside it, do not enter the area. The reason you should stay out, such as "Swim Area" may be printed in black on the marker.

Informational Markers are white signs with orange borders. They give information such as direction, distance, and location.

Lateral markers in the USWMS system are either numbered red or black buoys. Black buoys may have green reflectors or lights. They are the equivalent of green buoys in the IALA-B system. Red buoys may have red reflectors or lights. They are the same as red buoys in the IALA-B system. Red or black buoys are usually found in pairs – pass between them.

E. A Special Sign

In Florida, you may see a special sign: "Caution, Manatee Area". When you see this sign, slow down to idle speed. Manatees, an endangered species, are passive, large, slow-moving mammals. Many manatees are seriously injured or killed each year by boat propellers.

F. Noise

Always be aware of local laws on noise limits. Noise means engine noise, radio noise or even yelling by people on your boat. Good seamanship demands that you operate your boat quietly so as not to infringe on the rights of others. Do not use thru-hull exhaust unless you are well offshore.

G. Anchoring

The weight of the anchor and diameter of anchor line should be governed by the size and weight of your boat. Keep anchor secure while underway to prevent damage or injury due to sudden shifting in the boat's attitude.

Use two or more anchors if anchoring overnight or for extended periods. If not using two anchors, make certain there is sufficient clearance for your boat to swing in a full circle to prevent damage in case of shifting winds.

Make certain you have enough anchor line (or scope) for the depth of water. Your anchor line should be 6 to 7 times the depth of water anchored in. For example, if you are in 20 feet of water, use 120 to 140 feet of anchor line.

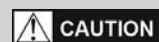

Secure anchor line to bow eye or deck cleat. Never tie anchor line to a rail, rail fitting or other hardware not designed to support this stress.

To drop anchor:

Approach your selected anchoring site from downwind and come to a dead stop over the spot where you want to drop anchor. Lower the anchor manually or by using the windlass if applicable.

Maneuver the boat slowly backwards until length of anchor line is 6 or 7 times the depth of the water.

Fasten the anchor line around the bow eye or deck cleat. Anchor flukes should dig in and catch. Watch for anchor drag by checking shoreline landmarks at the time the anchor is dropped and one-half hour later. If the boat has drifted away from these reference marks, the anchor is dragging and must be reset.

To weigh anchor:

Start the engine running before pulling in anchor.

Slowly maneuver the boat forward to reduce tension on the line and make retrieval of the anchor line easier.

Raise the anchor manually or by using the windlass if applicable. Make sure the chain stop is engaged if windlass is used. Properly stow anchor and anchor line.

 **WARNING**

Always be sure to raise and secure the anchor prior to operating your boat. Failure to raise and secure anchor before getting underway could result in severe injury or damage to boat from rebounding anchor.

 **WARNING**

Always utilize the chain stop provided with the windlass/bow roller combination. The chain stop prevents the anchor from accidentally releasing while the boat is moving thus preventing damage to the boat or possible injury or death to individual(s) aboard the boat.

If the anchor becomes stuck, attach the vertical line to the mooring cleat. Wave action on the bow may lift flukes from the bottom and free the anchor. If the anchor is still stuck, feed out a few feet of line and attach it to the bow cleat. Maneuver the boat around the anchor, keeping the line firm. Determine the angle that will work to pull the anchor free.

Anchors are available in different shapes, sizes and weights to fit different boats, uses, and conditions. Your Four Winns dealer can tell you which anchor will work best for your boat.

C - 3 RECOMMENDED READING

We recommend that you read the boating literature published by your state boating agency and the US Coast Guard. Other suggested reading includes the following:

Damford, Don. Anchoring. (ISBN 0-915160-64-1). Seven Seas.

United States Coast Guard Auxiliary. Boating Skills and Seamanship. LC74-164688.(illus.). (ISBN 0-930028-00-7). US Coast Guard.

Bottomley, Tom. Boatman's Handbook, (illus.). 316 p. (ISBN 0-688-03925-1, Hearst Marine Book). Morrow.

Whiting, John and Bottomley, Tom. Chapman's Log and Owner's Manual. 192 p.(ISBN 0-686-96737-2). Hearst Marine Book.

Chapman, Charles F. and Maloney, E.S. Chapman's Piloting, Seamanship and Small Boat Handling. (illus.). 62 p. (ISBN 0-87851-814-2, Pub. by Hearst Bks.); deluxe ed. (ISBN 0-87851-815-0). Morrow.

National Fire Protection Association. Fire Protection Standard for Pleasure and Commercial Motor Craft. (ISBN 0-317-07388-5, NFPA 302). National Fire Protection Association.

Brotherton, Miner. Twelve-Volt Bible. (ISBN 0-915160-81-1). Seven Seas.

C - 4 CONTACTS

There are many good boating publications that have information about your area and what other boats are doing, such as clubs and other activities. Educational programs are sponsored by publications and organizations such as the US Power Squadron, US Coast Guard Auxiliary and the American Red Cross. See your dealer about special courses available in the area. For detailed information contact:

American Red Cross
Local address (see local telephone directory)
website: www.redcross.org

Boat US Foundation for Boating Safety
1 800-336-BOAT
website: www.boatus.com/courseline

US Coast Guard Info Line
1 800 368-5647

Skippers Course
GPO Superintendent of Documents
Washington, DC 20012
202 512-1800
202 512-2250 (fax)

United States Coast Guard Auxiliary
Local Flotilla or contact appropriate Coast Guard District Headquarters
website: www.cgaux.org

United States Coast Guard Headquarters
2100 2nd St., SW
Washington, D.C. 20593-0001
202 267-1060
website: www.uscgboating.org

United States Power Squadron
P.O. Box 30423
Raleigh, NC 27617
website: www.usps.org

C - 5 OWNER'S LOGS AND RECORDS

At the end of this owner's manual are several forms which you will find very helpful.

The **Float Plan** provides a record of your destination, departure and return times, boat description, passenger list, and other information about the trip you have planned. At the bottom of the form is space for listing emergency telephone numbers in case your return is delayed past the expected time. It also has space for indicating information about the person filing this report. Leave the completed form ashore with a responsible person. We recommend you make several copies of this form each boating season to assure an ample supply.

The **Fuel Log** is a handy way to record information covering engine hours, fuel consumption, miles traveled, as well as RPM (revolutions per minute), average MPH (miles per hour) and GPH (gallons per hour).

The **Service/Maintenance Log** provides a record of maintenance work completed, the date of completion, and the engine hour reading. This log also helps you identify the frequency of routine maintenance work, such as engine oil changes. If you should decide to sell your boat, it demonstrates to perspective buyers that you have done a good job taking care of it.

The **Service Information Sheet** allows you to record all the pertinent information regarding your Four Winns® boat. This sheet will be extremely helpful when ordering additional/optional parts for your boat or when having service work done.

C - 6 NAVIGATIONAL AIDS CHART

The illustrated Navigational Aids Charts contain information concerning whistle signals, storm warnings, bridge signals, and buoy descriptions. See the inside back cover of this manual.



D - 1 FOUR WINNS WARRANTY POLICY

The Four Winns Winning Edge™ Owner Protection Plan provides the new Four Winns purchaser with one of the most comprehensive corporate commitments in the marine industry today. The Winning Edge™ Owner Protection Plan defines the warranty coverage on all units manufactured by Four Winns. It thoroughly describes the warranty policies and those procedures to be followed to obtain warranty coverage. Review the Four Winns Owner Protection Plan and limited warranty statements carefully.

All engines utilized in the Four Winns® product are warranted by the engine manufacturer. Your Four Winns dealer is authorized to repair your engines and will work closely with the engine manufacturer to resolve any problems you have.

D - 2 DECK/HULL STRUCTURE WARRANTY

Each unit manufactured by Four Winns is encompassed by a separate warranty providing specific coverage on the deck/hull structure. The Winning Edge™ Owner Protection Plan thoroughly describes this coverage.

D - 3 WARRANTY REGISTRATION

A Four Winns Warranty Registration Card is attached to the Winning Edge™ Owner Protection Plan statement. Your Four Winns Dealer is responsible for completing and mailing the warranty card at the time of purchase. The receipt of the warranty card is the sole basis for establishing proof of ownership of the boat and corresponding warranty validation.

By signing the warranty registration card you, the new owner, indicate an understanding of the terms and conditions of the Limited Warranty. The warranty registration card should be properly completed by the dealer, signed by the new owner, and returned to us within fifteen (15) days after the original purchase in order to validate the warranty. This is a dealership's responsibility. Be sure to keep the Owner's Registration Card for your records.

All boat manufacturers are required by The Federal Boat Safety Act of 1971 to notify first time owners in the event any defect is discovered "which creates a substantial risk of personal injury to the public." In order for us to notify you if necessary, be sure to verify the accuracy of the embossed Winning Edge™ card upon receipt. You should receive your Winning Edge™ card

within approximately 30 days from the day of your boat purchase. If you have not received your Winning Edge™ card within this time frame please contact your Four Winns selling dealer for resolution. If upon receipt of the card you discover a discrepancy, please notify Four Winns at 231 775-1343. A corrected Winning Edge™ card will then be sent to you.

Other equipment manufacturers also require that their products be registered with the respective companies. Warranty registration cards are provided in the owner's information packet.

D - 4 TRANSFER OF WARRANTY

Four Winns' confidence in the product and our warranty commitments can extend after the original purchaser may choose to move on to a new boat. The remainder of the Four Winns warranty coverage is transferable to the second owner of the boat for a fee. The warranty may be transferred only once. Registration of the second owner is required and the amount of the transfer fee is indicated on the warranty statement of the Warranty Registration Card. Transfer of the remainder of the warranty must occur within five (5) years of the original retail sale. The transfer fee must be paid within fifteen (15) days of purchase of the used boat by check, money order or cashier's check payable to Four Winns. Proof of purchase date is required. We will notify the appropriate engine manufacturer of the boat warranty transfer. The Winning Edge™ Owner Protection Plan thoroughly describes the action required to transfer warranty coverage.

D - 5 PRE-OWNED UNIT REGISTRATION

Section E-4 Transfer of Warranty discusses the need to properly register the purchase of a pre-owned boat with Four Winns in order to transfer applicable warranty coverage.

Purchasers of all Pre-Owned Four Winns models, regardless of the decision to transfer warranty coverage, are encouraged to register ownership with Four Winns. To register ownership of a "Pre-Owned Four Winns® boat," provide Four Winns with your name, address, daytime phone number, e-mail address, purchase date, and hull serial number of the boat purchased. The hull serial number plate is permanently affixed to the starboard side of the transom. Registration of a Pre-Owned Four Winns® boat does not extend or in any way affect or modify the specific

terms of the Winning Edge™ Owner Protection Plan or Limited Warranties. We provide this service to the purchasers of Pre-Owned Four Winns® boats in the interest of better boating. Four Winns welcomes every purchaser of a Four Winns® boat, new or used, to our family.

D - 6 INSURANCE COVERAGE

One of your responsibilities as a new boat owner is to acquire proper insurance protection. Insurance should include comprehensive and general liability coverage appropriate to your financial needs. Please contact your local agent for assistance on insurance coverage.

D - 7 SERIAL NUMBER RECORD

The manufacturer, model, and serial number of major components are recorded during the assembly of each Four Winns® boat. A copy of this form is included in the owner's packet. Using this form, you may want to have your dealer help you complete the service information form at the back of this manual. A copy of the serial number record should be made and kept by the dealer in his records. This can assist the dealer in processing warranty claims, or obtaining necessary information. The original copy of the serial number record should be kept in the owner packet. The service information form should remain in the owners manual for easy reference.

D - 8 PRE-DELIVERY SERVICE

Four Winns makes every effort to deliver your boat in "turn key" condition to the dealer. The process of transporting and handling the boat necessitates certain inspections and adjustments prior to delivery to you. Also, various aspects of operation must be checked and adjusted immediately prior to final delivery and use.

The selling Four Winns dealer must perform this thorough review of the boat and its numerous systems during the commissioning or "dealer pre-delivery service" of the craft.

A Four Winns Pre-Delivery Inspection Form is part of the Warranty Registration Card. It lists the many items encompassed by the pre-delivery service previously described. The dealer is to check off the items as they are completed, and complete the form as indicated providing specific performance related information appropriately.

Your Four Winns dealer will sign the Pre-Delivery Inspection Form of the Warranty Registration Card upon completion of the work. You will also be asked to sign the Pre-Delivery Inspection Form upon accepting delivery of the boat. You are to retain the two copies marked "Boat Owner". Your dealer is to retain the copy marked "Dealer copy" for his records. The Manufacturer's copy is electronically sent to the Four Winns Customer Service Department.

D - 9 REPLACEMENT PARTS

Four Winns dealers are equipped with a Four Winns parts manual that details the components of each model and their appropriate part numbers. Many Four Winns dealers inventory common replacement components.

In addition, Four Winns maintains specific records on the components used in the manufacture of each unit and makes a concerted effort to maintain components specifically to fill replacement part needs.

The Four Winns dealer from whom you purchased your boat is in the best position to meet your needs. If the dealer does not have the needed item, the dealer has the capability, through direct contact with the Four Winns Customer Service Department, to obtain it quickly. Four Winns will only sell replacement parts to established Four Winns dealers. If you relocate and cannot find a Four Winns dealer close to you, contact the Four Winns Customer Service Department for information on the nearest dealer in your area.

D - 10 OWNER'S RESPONSIBILITIES

1. Sign the warranty registration card verifying your address, model and hull serial number. The dealer is responsible for mailing the warranty registration card to us.
2. Inspect the boat at the time of delivery to verify that all systems and components are operating safely and acceptably. Read all manuals and instructions.
3. Operate all equipment in compliance with the manufacturer's instructions.
4. Review the pre-delivery checklist for the boat and engine with your dealer when you take delivery.
5. Schedule your 20-hour boat and engine checkup with your dealer.

6. Know how to safely operate your boat and the rules of the road before you use your boat.

IMPORTANT: Make sure that your dealer checks the engine alignment during your boat's 20-hour checkup. The engine alignment check should be performed in accordance with recommended procedures as stated by the engine manufacturer in your engine owner's manual. Failure to do so could result in drive train damage which is not covered under the warranty.

7. We recommend that you review your engine owners manual and warranty certificate for break-in advice, initial inspection and service requirements.
8. Perform or provide for the scheduled maintenance checks outlined in this manual and all related service guides and manuals.
9. You are responsible for any modifications made to the boat or its equipment that could affect the safe operation of the boat.

Along with boating, comes responsibility. Responsibility for safety, boating laws, and the environment. Please think about the future of our waterways, oceans and marine life while you're out enjoying them and take all necessary measures to help protect what natural habitats we have left. Keeping our waterways and marine habitats free from debris, and showing consideration for the creatures who thrive in these environments are some ways you can help assure the pleasure of boating for years to come.

The operator is also responsible for complying with the following procedures and operational requirements:

- State registration
- Insurance
- Warranty registration
- Warranty terms and conditions
- Rules of the road
- Break-in procedure
- Proper maintenance of the boat and its systems
- Safety equipment
- Safety training of passengers and crews
- Knowledge of boat systems
- Seaworthiness/operational inspection
- Safe operating practices
- Avoiding use of drugs/alcohol
- Environmental regulations
- Accident reporting

D - 11 CONSTRUCTION STANDARDS

All Four Winns® boats meet or exceed the construction standards set by the US Coast Guard and the American Boat and Yacht Council (ABYC) concerning:

- Navigational lights
- Factory-installed fuel systems
- Engine and fuel tank compartment ventilation
- Flotation
- Steering systems
- Backfire flame arresters

We recommend that you see your dealer if you wish to modify factory-installed equipment or add new equipment. Your dealer is qualified to make such modifications or additions without placing the safety or design integrity of your boat at risk and without invalidating the warranty.

D - 12 WINNGEAR

Show your colors! Four Winns offers a complete line of sports clothing designed to complement your new boat. The WinnGear™ line is on display on our website at www.fourwinns.com.

Please place in envelope and mail to: Four Winns
925 Frisbie Street | Cadillac, MI 49601

 **FOUR WINNS®** **NAME / ADDRESS CHANGE FORM**

Name & Address:
Please print clearly.

Telephone & E-Mail Address:

Hull Identification Number:

Boat Model:

Date of Purchase:

NOTE: For warranty transfer please use the Warranty Transfer Request Form also included in this manual.

Please place in envelope and mail to: Four Winns
925 Frisbie Street | Cadillac, MI 49601

 **FOUR WINNS®** **NAME / ADDRESS CHANGE FORM**

Name & Address:
Please print clearly.

Telephone & E-Mail Address:

Hull Identification Number:

Boat Model:

Date of Purchase:

NOTE: For warranty transfer please use the Warranty Transfer Request Form also included in this manual.

 **FOUR WINNS®** **NAME / ADDRESS CHANGE FORM**

Name & Address:
Please print clearly.

Telephone & E-Mail Address:

Hull Identification Number:

Boat Model:

Date of Purchase:

NOTE: For warranty transfer please use the Warranty Transfer Request Form also included in this manual.





FOUR WINNS L.L.C., 925 Frisbie Street, Cadillac, MI 49601 Phone (231) 775-1343

WARRANTY REGISTRATION TRANSFER REQUEST

Original Owner Name & Address: _____

Original Date of Purchase: _____

Hull Identification Number: _____

Boat Model: _____

Selling Dealer: _____

Name and address of new purchaser: _____

Telephone & E-Mail Address: _____

Date of Purchase: _____

The warranty may be transferred only once. Registration of the second owner is required and the amount of the transfer fee* is indicated on the warranty statement of the Warranty Registration Card. Transfer of the remainder of the warranty must occur within five (5) years of the original retail sale. The transfer fee must be paid within fifteen (15) days of purchase of the used boat by check, money order or cashier's check payable to Four Winns. We will notify the appropriate engine manufacturer of the boat warranty transfer.

This warranty registration request if accepted, transfers the warranty coverage remaining on the boat to the new purchaser. Acceptance of this request does not create any additional warranties or obligation on Four Winns.

Warranty Expiration Date: _____

Four Winns Transfer Acceptance Date: _____

Four Winns Authorized Signature: _____

Mail to Four Winns L.L.C., 925 Frisbie Street, Cadillac, MI 49601, Attn: Customer Service Department.

***Subject to change without notice.**



E - 1 GENERAL

DO NOT attempt to service any engine without being totally familiar with the safe and proper service procedures. Do not attempt to maintain or adjust an engine while it is running. Certain moving parts are exposed and failing to shut off the engine can result in serious injury or death.

Four Winns does not manufacture engines or drives. Because of the technical nature of the engine and drive systems, all manufacturers of these items require that warranty and service problems be taken directly to an authorized dealer for resolution. The Four Winns dealer from whom you purchased your boat, will handle all warranty and service matters with the engine manufacturer for you.

In compliance with the Federal Boat Safety Act of 1971 all engine manufacturers require their products to be registered. A registration card is furnished with each new engine. When selling a Four Winns® boat, the dealer, along with the purchaser, should complete the information requested on these cards and return them to the respective engine manufacturers. Engine registration cards are provided with the engine and will usually be found with the boat literature.

Each manufacturer of the various marine power components provides an owner's information manual with their product. This publication is included with this manual. It is important that you read the manual(s) carefully and become completely familiar with proper care and operation of the engine and drive system. Be sure to read the section on winterization. Replacement costs associated with frozen engine blocks, drive systems and other components are quite substantial.

Also review the other sections in this manual, especially Sections I on Fuel Systems, and Section F on Control Systems.

E - 2 ENGINE EXHAUST
A. Carbon Monoxide

The carbon monoxide in exhaust fumes can be hazardous. It is important for you and your passengers to be aware of the potential safety hazard

created by exhaust fumes. Familiarize yourself with the symptoms of individuals overcome by carbon monoxide, and most importantly, ways you can protect yourself and your guests.



DO NOT inhale exhaust fumes! Exhaust contains carbon monoxide which is colorless and odorless. Carbon monoxide is a dangerous gas that is potentially lethal.

Persons overcome by carbon monoxide may exhibit the following symptoms:

- a. *Watering and itchy eyes*
- b. *Flushed appearance*
- c. *Throbbing temples*
- d. *Inattentiveness*
- e. *Inability to think coherently*
- f. *ringing in the ears*
- g. *Tightness across the chest*
- h. *Headache*
- i. *Drowsiness*
- j. *Incoherence*
- k. *Nausea*
- l. *Dizziness*
- m. *Fatigue*
- n. *Vomiting*
- o. *Collapse*
- p. *Convulsions*

IF YOU THINK EXHAUST FUMES ARE ENTERING YOUR BOAT, DETERMINE THE CAUSE AND HAVE IT CORRECTED IMMEDIATELY!

The following suggestions can help prevent exhaust fumes from entering the boat or injuring people in the vicinity:

1. DO NOT allow the boat to remain stationary with the engines running for an extended period of time. Do not stand or swim near the exhaust output or outdrive when the engine is idling.
2. Use extreme caution while operating the engines in confined areas such as enclosed slips, congested piers, or in any area where the exhaust outlets are facing or near a bulkhead or wall structure of any kind. Operation under such conditions could easily lead to exhaust gasses (carbon monoxide) entering even though you may have all the hatches, windows, doors and portholes closed.

3. Never operate your generator while the boat is moored against any other boat, dock or wall structure that is against or near the exhaust outlet. Again, operation under such conditions could easily lead to exhaust gases (carbon monoxide) entering your boat or the boat to which you are moored, even though you may have all the hatches, windows, doors, and portholes closed.
4. Under certain conditions, exhaust gases can enter the boat through the sink drains. Each sink drain has a water trap installed to help prevent this. To be effective, the sink drains must have water in them. Normal use of the sinks will provide the water needed for this to occur.
5. Persons sleeping can be easily overcome by carbon monoxide because they are unaware of its presence. Sleeping with the engines or generator running is not recommended. If persons are sleeping aboard while underway, or while the generator is running, those awake should monitor for carbon monoxide accumulation in the cabin; especially the sleeping areas. Open forward facing windows or deck hatches to provide fresh air ventilation. Keep hatches, windows, and doorways that face aft or towards the exhaust discharge closed.



NEVER operate the propulsion engine(s) or generator while everyone on-board is sleeping. Fatal carbon monoxide poisoning can occur.

6. If possible, ventilate your cabin while under way. Open a forward hatch or window to allow air to travel through the cabin. Do not operate the boat with the cabin door(s) or windows that face aft, open. The natural vacuum created during operation may allow exhaust gasses to be drawn into the cabin.

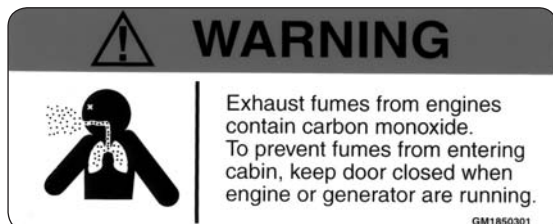

Carbon Monoxide - Cabin Doors Warning Label

NOTICE

Current deck hatches are designed to allow ventilation when latched in a partially open position.

7. Inspect the engine exhaust system frequently for water and exhaust gas leakage, hose deterioration, and loose hose clamps. See Section R - General Maintenance for additional information.
8. Have a competent marine engine service technician inspect your exhaust system whenever your boat is in for service, or if you notice a change in the sound of your engines.

For additional information, refer to Section B-2 - Carbon Monoxide.

B. Carbon Monoxide Monitor

A carbon monoxide (CO) monitor(s) will sound an alert should carbon monoxide reach an unsafe level in the cabin of your Vista®. The CO monitors are standard equipment and are located in the aft cabin and forward cabin. Refer to the manufacturer's literature included with the owner's packet.



Never disarm a CO detector. If a CO detector alarms, immediately ventilate the area and check passengers for symptoms of CO intoxication. See your Four Winns dealer for assistance in diagnosing the cause for the alarm.

E - 3 ENGINE & DRIVE SYSTEM

A. Engine

The 318 Vista® model is equipped with twin engine propulsion. A choice of Mercruiser® or Volvo Penta® engines are offered. Please consult the engine owner's manual provided with this manual for operation and maintenance information. See your Four Winns dealer for complete engine availability.

B. Stern Drive

A stern drive or inboard/outboard propulsion system has a piston engine equipped with special marine components mounted near the transom and coupled to an external outdrive-type transmission unit. Shifting is performed within the outdrive upper gear case. This type of system is depicted in Figure E-1.

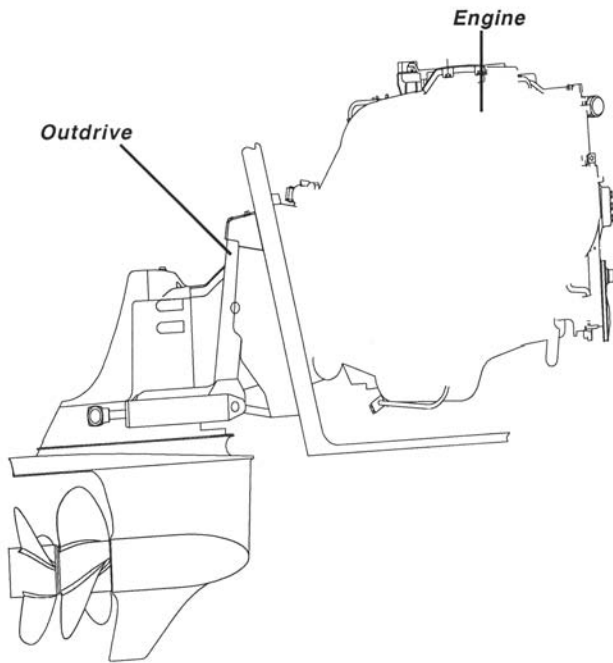

Figure E-1: Stern Drive

NOTICE

Always return the engine throttle lever to the extreme low speed position before shifting. NEVER shift the unit while engine speed is above 800 rpm.

E - 4 PROPELLERS

Knowledge of the propeller is most easily gained through better understanding of the terminology used to refer to the aspects of propeller size and performance. It should be noted that on most 318 Vista® models include stainless steel propellers.

A. Diameter

Diameter is twice the distance from the center of the prop shaft to the extreme tip of a propeller blade. Increasing or decreasing propeller size will have a direct bearing on the RPM's an engine will develop.

This is due to the greater amount of propeller blade surface in contact with the water. See Figure E-2.

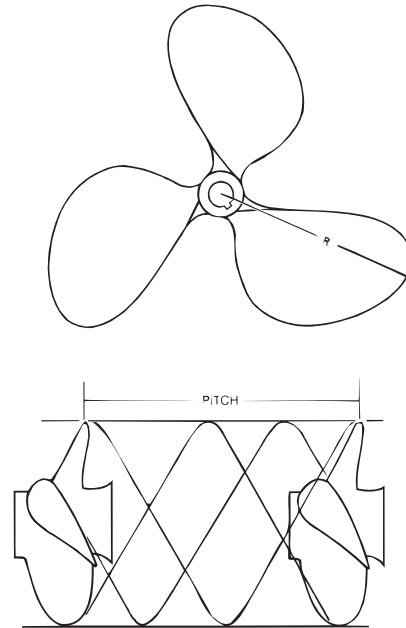

Figure E-2: Propeller Pitch & Diameter

B. Pitch

Pitch is a measure of helix angle, or angle of attack, of the rotating blade. Pitch is easily understood if one imagines the propeller rotating through a semisolid such as butter or gelatin. The distance the propeller will travel in one revolution is called "Pitch." Increasing or decreasing pitch will also have a direct bearing on engine RPM's because of the greater bite taken by the blade with each rotation. See Figure E-2.

C. Prop Slip

When traveling through water a propeller is unable to get a complete bite because of the fluidity of water. "Prop slip" is usually expressed as a percent of the computed theoretical speed. Twenty-five to thirty-five percent prop slip is common for a cruiser-type boat operating at cruising speed.

Changing either diameter or pitch will have an effect on engine speed and prop slip, and in turn, directly effect the performance of a boat. The propellers included with each Four Winns® boat provide the best general performance based on data obtained from on-the-water testing of that model. Variations in load, operating conditions, environment, the individual engine and hull performance may necessitate the purchase and use of another propeller(s).

Under your normal load conditions, the engines should turn within the maximum RPM range when at full throttle. If the engines exceed the recommended RPM, an increase in pitch or diameter is required. If the engine RPM is too low, a decrease in pitch or diameter is required.

The load carried in a boat will directly affect performance of the engine. If an engine that is not developing full power, be sure the engine is properly tuned and load conditions are those normally experienced, before changing propellers.

NOTICE

For twin engine installations, always check drive shaft rotation before propeller installation. A right hand rotation propeller must be installed on the starboard propeller shaft. Similarly, a left hand prop must be installed on the port propeller shaft.

For shipping reasons, the propellers are not factory installed. Initial installation of the propellers will be performed by the dealer during pre-delivery service. See Figure E-3.

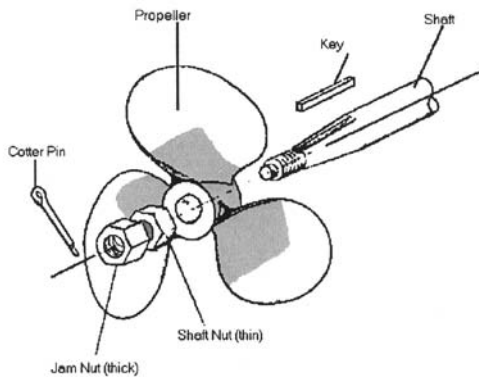

Figure E-3: Prop Installation

NOTICE

Should it be necessary to change propellers, always use an appropriate propeller removal tool or "Prop Puller." DO NOT attempt removal using a hammer. Damage to the propeller or propeller shaft can result.

Always check shaft rotation before propeller installation. A right hand rotation propeller must be installed on the prop shaft connected to a starboard engine. Similarly, a left hand prop must be connected to the port engine shaft. The propellers must rotate outboard not inboard.

Be sure the propellers are of the correct blade configuration, diameter, pitch, and shaft size to assure good performance. For additional information on factors affecting performance and/or assistance with your selection, please consult your Four Winns dealer.

E - 5 ENGINE COOLING SYSTEMS

A. Raw Water Cooling

Certain stern drive engines utilize a raw water cooling system. This cooling system is a seawater system. Seawater (raw) water is taken in through water inlets on the both sides of the lower gear unit of the stern drives models. Water pumped to the engine by the seawater pump is circulated through the engine by the engine circulating pump. A thermostat controls the engine operating temperature by determining the amount of water to be taken in, recirculated and discharged. The water is discharged through an idle exhaust relief and the exhaust through the propeller hub. A temperature gauge(s) located on your instrument panel monitors engine(s) temperatures.

CAUTION

Never operate your engine without a thermostat. Engine damage can occur and is considered operator negligence and therefore not covered under the engine warranty.

CAUTION

If engine should overheat, turn off engine, look for obstructions to water pick-up. If any obstructions are found, clear the obstructions and run engine again at 1500 RPM in neutral and check temperature gauge to verify condition. If overheating still occurs, return to port at low RPM to prevent excessive overheating and engine damage. Consult with your certified engine dealer for service.

NOTICE

When laying up the boat for winter it is important that the cooling system be flushed with fresh water so that deposits do not dry and to prevent the buildup of salt crystals. Please consult your engine owner's/operator's manual for proper engine and cooling system winterization procedures.

B. Fresh Water Cooling

Certain Vista® stern drive models include a “closed water cooling” system. This system provides adequate engine cooling without exposing the internal engine to the detrimental effects of surface water, including salt, highly polluted or silt-laden water. The engine owners manual provides additional information regarding service and maintenance of this equipment. See your Four Winns dealer for availability.

These Vista® models use surface water as a cooling medium for the heat exchanger. The cooling water employed enters the system through a water intake and is relinquished through the exhaust manifold system. Some boating areas require that additional water intake filters be installed. Reference Section P-3 - Equipment Installation, in this manual for installation instructions and consult your Four Winns dealer regarding any special equipment that may be required.

WARNING

Should an engine intake or an exhaust or cooling hose rupture, turn the engine off and close the seacock immediately. Proceed under tow, if necessary, to a service facility for appropriate repairs; maintain a close visual watch on the problem hose and also on the bilge water level.

E - 6 RUNNING ANGLE & POWER TRIM/TILT

Hull planing surfaces have the least amount of drag at a three to five degree angle with the water. This is the preferred running angle when boating. The running angle has a significant impact on top speed and handling. Heavy load or certain water conditions may make it difficult to achieve the optimum running angle. See Figure E-4.

The running angle can be controlled through the use of power trim (stern drives) and/or trim tabs. See Section E-8 - Trim Tabs and Section S-7 - Trimming Your Boat for information on the use of trim tabs and tilt/trim control switches.

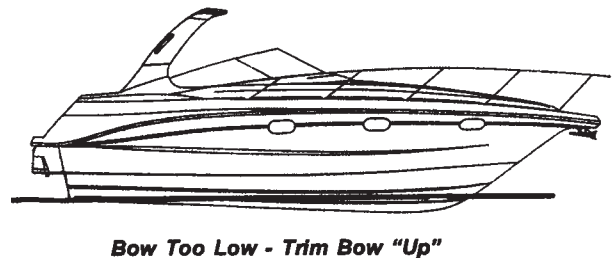
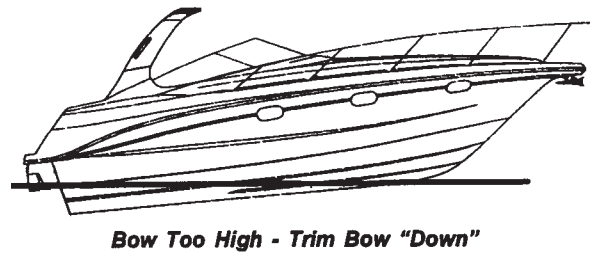
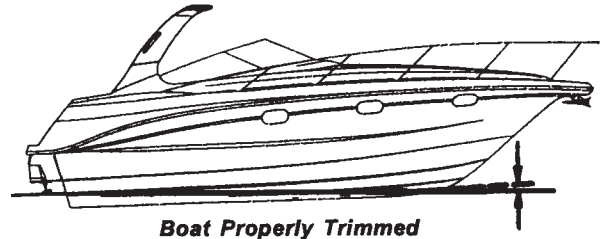

Figure E-4: Running Angle

A. Power Trim

Trim angle is how far in or out, the lower unit is positioned in relation to the bottom of the boat. The trim angle of the lower unit has a distinct affect on the running angle of the boat.

The power trim system permits control of the trim angle of the drive unit relative to the boat, at the touch of a button.

It allows the drive unit to be raised (trimmed out) for shallow water operation. Power trim also allows the operator to adjust the drive unit while underway to provide the ideal running angle for a given load and water condition. Additional information can be found in the engine owner's manual.

B. Power Tilt

Power tilt allows the operator to raise and lower the drive unit for trailering, launching, and beaching. Additional information on power tilt can be found in the engine manufacturer's manual included with this manual.

NOTICE

DO NOT operate the engine with the stern drive tilted up. Severe damage to the engine drive system can result. Consult the Engine Owner's manual for specific information.

E - 7 TRIM TABS

Electric/hydraulic trim tabs are standard equipment and help provide maximum control of the hull in all water and load conditions. If used properly, trim tabs can:

- Compensate for wind and load listing (level the boat side to side).
- Induce faster planing and help achieve optimum running angle (see Section E-7 - Running Angle & Power Trim/Tilt).

The proper use of electric/hydraulic trim tabs requires a basic understanding of trim tab operation and some practice in calm water. Be sure to read the manufacturer's literature included in the owner's packet.

The trim tab control uses two (2) momentary-type rocker switches. The trim tab switches control the attitude or position of the boat. The trim tab switches are labeled by position such as "Bow Up" and "Bow Down". They are also labeled for "Port" and "Stbd". When pressed, the label indicates what happens to the bow of the boat.

Before leaving the dock and utilizing the trim tabs, ensure the trim tabs are in the full up position. Press both lower halves of the trim tab switches and hold (for approximately 10 seconds) until the tabs are full up.

A. Control Listing

Wind, loading and many other factors can result in the boat tilting or leaning towards one side while running. This is called listing and can be negated using trim tabs.

Pressing the lower port trim tab switch will move the starboard trim tab upward. This will result in the port bow of the boat being allowed to rise.

Pressing the lower starboard trim tab switch will cause the port trim tab to move upward and will result in the starboard bow being allowed to rise.

Pressing the upper port trim tab switch will cause the starboard trim tab to move downward and will force the port bow downward.

Pressing the upper starboard trim tab switch will cause the port trim tab to move downward and will force the starboard bow downward.

Always establish your intended heading and attain desired cruising speed before trying to adjust running attitude (using the trim tabs).

WARNING

Always press the trim tab switches in short one (1) second bursts. If pressed too long, you can overcompensate, and potentially lose control. DO NOT try to correct the situation by pressing the other upper trim tab switch. Instead, raise the tab slightly by pressing the appropriate lower half of the trim tab switch.

After stabilization of speed and direction, press the upper half of the appropriate trim tab switch to achieve a level side to side running attitude. Be sure to press the correct trim tab switch to obtain the desired result.

After pressing a trim tab switch, always wait and allow time for the change in trim tab position to take effect. DO NOT continue to press the trim tab switch while awaiting trim tab reaction. By the time the effect is noted, the trim tab will move too far and thus overcompensate.

B. Induce Planing & Controlling Trim Angle

Trim tabs can also be used to facilitate faster planing and allow better control of the running angle.

Before accelerating and trying to gain plane, press both upper trim tab switches. This will cause both trim tabs to move downward and force the bow down when running. This can also be used when running the boat with a heavy load aboard.

Moving the trim tabs downward will increase the lift and the boat will achieve plane faster, or stay on plane at a lower engine and boat speed.

After gaining plane and establishing cruising speed, pressing both lower trim tab switches will cause both trim tabs to move upward and will allow the bow to rise. This should be used to adjust the running attitude of the boat to decrease the drag at cruising speed or above, or when running in a following sea. When running at an engine speed that results in the boat falling off plane or causes the boat to plane inefficiently, lowering both tabs slightly (bow down) will improve the running angle and improve operating efficiency.

Optimum efficiency is obtained when operating at a 3 to 5 degree running angle. Utilizing too much "Bow Down" trim tab can reduce operating efficiency and cause substantial steering and handling difficulties. Be extremely careful when running in a following sea. The effect of trim tabs is amplified under such conditions. Steering and handling difficulties can result from improper trim tab usage, especially in a following sea. If unsure of proper trim tab positioning, raise the trim tabs to the full-up position.

 **WARNING**

When running at high engine speeds, be sure the trim tabs are in the full up position. Trim tab action should be only enough to compensate for any listing. Trim tab adjustments at high speeds are extremely critical. Be prepared to slow down should handling difficulties arise.

When running in a displacement (very slow speed) mode, better efficiency will be obtained with the trim tabs in the full-up position.

C. Trim Tab Maintenance

Check the fluid level of the trim tab reservoir often. Always keep the fluid level between the designated marks on the trim tab pump-reservoir. Refer to the manufacturers information for specifications on the type of fluid to be used and other operation and maintenance information.

E - 8 INSTRUMENTATION

The helm station is equipped with a complete set of engine instruments. These instruments allow the pilot to constantly monitor the operational condition of the

engine. Close observation of these instruments could save the engine from damage.

The 318 Vista® models have individual gauges in the dash panel as standard instrumentation. See Figure E-5.



Figure E-5: Vista Helm Station
(Representative View - Models May Vary)

A. Tachometer/Hour Meter Gauge

The tachometers indicate the speed of the engines in revolutions per minute (RPM) and are preset by Four Winns. This speed is not the boat speed or necessarily the speed of the propeller. They may not register zero with the ignition key in the OFF position. Note: The 318 Vista® models come with a tachometer/hour meter combination gauge which allows for hour meter viewing at the helm. Please refer to Section E-9J - Engine Hour Meter for information regarding the engine hour meter.

NOTICE

Never exceed the maximum recommended operating RPM of your engines. Maintaining maximum, or close to maximum RPM for extended periods can reduce the life of the engines.

Some engines are equipped with devices that limit engine RPM in accordance with the oil pressure or engine temperature. Refer to the engine owner's manual for additional information.

The tachometer must be set for different engines installed. This is typically done at the factory. The tachometer gauge is shown along with the table detailing the tachometer settings. See Figure E-6.

TACHOMETER SETTINGS

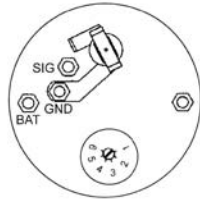

Set switch to match your engine.
CAUTION: Depress switch slightly while turning.

TACHOMETER SETTINGS	
NUMBER OF CYLINDERS	ENGINE SETTING
4*	1
6*	2
8*	3
12 POLE	4
(OB ALT)	
* 4 CYCLE ONLY	

Note: Setting information is labeled on the back of the tachometer.

Figure E-6: Tachometer - Rear View

B. Speedometer

A speedometer is not available on the 318 Vista® models. With the optional GPS/Navigational package the ability to monitor your speed becomes available. Please refer to the manufacturer's literature for programming the GPS unit for speed readings. This information is included in the owner's packet when the boat is ordered with the navigation package.

NOTICE

Speedometers/speed indicators are not precision instruments. The indications are relative and should never be used for navigational purposes or similar critical situations alone. Use other navigation systems in conjunction with the speedometer.

NOTICE

DO NOT rely on the speed indicator when trying to achieve a "NO WAKE" condition in a harbor or other enclosed waterway. ALWAYS be cognizant of the size of your waves your boat is making and reduce throttle until you are sure that they will not cause any damage. You are responsible for damage caused by the wake of your boat.

C. Temperature Gauge - (Included in 4-in-1 Gauge)

The temperature gauge monitors the cooling system of the engine. A sudden increase in the temperature could be a signal of a blocked cooling passage or a water pump malfunction.

NOTICE

Operation of an overheated engine can result in engine seizure. If an unusually high temperature reading occurs, shut the engine off immediately.

D. Oil Pressure Gauge - (Included in 4-in-1 Gauge)

The oil pressure gauge indicates the pressure in the engine lubrication system. A drop in oil pressure is a possible indication of oil pump or leakage problems.

NOTICE

Operation of an engine with abnormally low oil pressure can lead to engine damage and possible seizure. Have the engine serviced immediately upon a reduced oil pressure indication.

E. Voltmeter - (Included in 4-in-1 Gauge)

The voltmeter monitors battery condition and thus alternator performance. See Section H - Electrical Systems for additional information on voltmeter operation.

F. Fuel Gauge - (Included in 4-in-1 Gauge)

The fuel gauge displays the level of fuel that is present in the fuel tank. Refer to Section I - Fuel System for additional information.

Due to the mechanical nature of the fuel sender, variations in readings during various speeds of operation may occur. This system is merely a relative indication of the available fuel supply and not a calibrated instrument. Refer to Section I-1F - Fuel Senders for additional information.

NOTICE

Fuel gauges are not precision instruments. The reading is relative, and should never be relied upon as the sole indicator of fuel availability.

NOTICE

Use only clean, dry fuel of the type and grade recommended by the engine manufacturer. The use of incorrect or contaminated fuel can cause engine malfunction and serious damage. Refer to Section I - Fuel System for additional information.

G. Power Trim Gauge

The 318 Vista® models equipped with stern drives have a “power trim gauges.” This gauge provides a visual indication of the inward-outward (trim angle) position of the outdrive. There is not a trailer travel mode on the gauge.

H. Gas Vapor Detector

A gas vapor detector is optional equipment on the 318 Vista®. If equipped, the gauge mounts in the dash. Additional information can be found in Section I-1H - Gas Vapor Detector in this manual.

I. Engine Hour Meter

Engine hour meters are standard on the 318 Vista® models and provides a numeric record of elapsed engine operating time. This information is important in determining scheduled maintenance intervals, ships log data, cruise information, etc. The hour meter is located at the helm with the tachometer/hour meter combination gauge.

J. Ignition Switch

The ignition switch has three positions: OFF, RUN, and START. The START position is spring loaded and the key should be held in this position until the engine starts. The key will return to the RUN position once released. Always turn the key to the OFF position when the engine is not running. This will prevent discharging of the batteries. Additional information on ignition switch operation is covered in Section A - Operation of this manual.

K. Alarm System

The 318 Vista® models have an engine alarm system installed. This is an audible alarm that is mounted in the helm area; it is actuated by engine water temperature and engine oil pressure senders. The alarm will sound in the event of low engine oil pressure or high engine coolant temperature.

The engine alarm will sound during engine start-up, or whenever the ignition switch is positioned to ON and the engine is not operating. The alarm sounds under these conditions because engine oil pressure is low; the alarm will cease to sound as soon as engine oil pressure rises to the proper level.

NOTICE

The engine alarm monitors only engine water temperature and engine oil pressure. Always maintain a close visual watch on the drive(s), transmission(s), engine fluid levels, bilge water level, etc. Refer to the engine manufacturer's literature for additional information.

L. Navigational Equipment

Four Winns offers a navigational package as an option. See Figure E-7. Please consult the manufacturer's literature included in the owner's packet for operation and maintenance of these navigational systems (if installed).

NOTICE

Four Winns does not limit you to this specific navigational package mentioned above. There are many navigational systems on the market today. You may desire to use a different system based on your needs, personal preference, and mounting space available.

NOTICE

Four Winns continually strives to improve its products. Unit specifications, including standard and optional equipment are constantly being modified. Equipment availability is also subject to change. The most current and accurate information available at the time of publication is included in this manual. Some variation in equipment, description, location, and details can result.

NOTICE

These devices are only an aid to navigation. Their accuracy can be affected by many factors including equipment failure or defects, environmental conditions, and improper handling or use. It is the user's responsibility to exercise common prudence and navigational judgement. These devices should not be relied upon as a sole means of navigation nor as a substitute for such prudence and judgement.

The GPS navigational unit takes this information and uses it to determine the vessel's exact position and indicates the vessels position on the chart plotter. The chart plotter allows one's course to be plotted electronically. Factory installed GPS/Plotter system is one of the optional navigational packages offered. It is mounted at the helm. If equipped, refer to the manufacturer's literature included in the owner's packet.

NOTICE

You should not rely on these displays as your primary source of navigation. Rather, you should use the chart plotter as a backup to official government charts and traditional methods of navigation.



Figure E-7: Navigation Package
(Representative View - Models & Equipment May Vary)

Radar along with the GPS/Plotter is included in one of the navigation package option. The radar detects objects/targets and displays them for the operator to see. If so equipped, refer to the manufacturer's literature included in the owner's packet for operation instructions.

1. Ship to Shore VHF Radio

A VHF radio is optional equipment offered with the selection of the navigation package option. It provides reliable communication between vessels, and from ship to public or private shore stations. It is programmed for two-way communication on all the International, US and Canadian channels plus reception on separate weather channels, and the international calling and safety channels (16/9). The VHF radio with microphone is mounted on the helm. If equipped, additional information is included in the manufacturer's literature included in the owner's packet.

2. GPS/Plotter/Radar

A GPS/chart plotter is an electronic system through which a navigator can determine his position regardless of weather. The GPS sensor receives high frequency radio signals generated from satellites to generate coordinate readings on the display.

3. Depth Sounder

A depth sounder may be included with the navigation package option on the 318 Vista® models. Please consult the manufacturer's literature included in the owner's packet for operation and care of this particular depth sounder.

4. Compass

A compass is standard on the 318 Vista® models. See Figure E-8. The compass can provide directional information when operating offshore, in unfamiliar waters, or in adverse weather conditions.



Figure E-8: Compass

After all personal equipment is installed, including all electronics (VHF radio, GPS, chart plotter, etc.), the compass must be properly calibrated. DO NOT rely on the compass readings until initial adjustment (compensation) has been performed. The boat has a factory installed compass, the manufacturer's instructions are provided in the owner's packet. Most areas have local companies that specialize in compass adjustment. If unsure of the proper compensation techniques, consider having the adjustment done professionally to insure accuracy and confidence in the compass.

NOTICE

During use, keep all extraneous metal objects away from the compass. The close proximity of metal objects (e.g., beverage cans) can cause compass deviation.

M. Instrument Maintenance

Electrical protection for instruments and ignition circuitry is provided by a circuit breaker on the ignition panel. Periodically, spray the ignition switches with a contact cleaner. The ignition switches and all instruments, controls, etc. should be protected from the weather when not in use. Four Winns offers appropriate weather covers for each model. Excessive exposure can lead to gauge and ignition switch difficulties.

CAUTION

DO NOT use a product such as WD-40 as a contact cleaner. Be sure to read the label before using any product.

Electronic gauges are affected by static electricity that builds-up on the glass face. Periodic washing of the gauge face with warm water and mild liquid detergent will help eliminate the static electricity problem and improve gauge accuracy.



F - 1 GENERAL

Control systems permit operation of the engine's throttle and shift mechanisms. Typically, they consist of three major components; the control, the throttle and shift cables.

The 318 Vista® stern drive models are equipped with dual engine binnacle control with trim. See Figures F-1 and F-2. The left lever controls the port engine and the right lever controls the starboard engine. Moving the lever forward will shift the drive into forward. Moving it aft will shift the drive into reverse. Moving the lever further will increase engine speed.



Figure F-1: Dual Engine Binnacle Control



Figure F-2: Helm Station

NOTICE

Allow the engine to warm up before engaging the shift control. Monitor all instruments while engine is idling during warm-up.

F - 2 CONTROL OPERATION
A. General
NOTICE

The control information included in this section is general only. For specific operation of the controls on your boat, refer to the control manufacturer's literature and engine manufacturer's literature included in your owner's packet. Ensure you completely understand the operation of the controls before operating your boat. Also consult your dealer should any questions arise regarding the operation of the control unit.

NOTICE

If your boat is equipped with a non-OEM remote control system, ask your dealer how to properly operate it.

NOTICE

Reduce throttle as soon as motor starts. Do not run a cold motor any faster than necessary to keep motor from stalling. Do not exceed 2000 RPM in NEUTRAL.

During the general operation of a twin engine boat, it is advantageous for both engines to be operated at the same engine speed (rpm). This reduces noise and vibration, and can increase propulsion system efficiency. Setting the throttles so the engines are running at the same rpm (synchronized) can be done by engine sounds or by an engine synchronizer gauge. Attempting to synchronize the engines solely by using tachometer readings or manually controlling the throttle lever placement will generally not be effective. When the engines are in proper synchronization, the throttle levers may not necessarily be in the same position.

B. Maneuvering Dual Binnacle Controls

Shifting and engine speed are controlled with the same lever (1). See Figure F-3.

N - Neutral position. Drive/Reverse gear disengaged.

F - Drive/reverse gear engaged for forward movement (ahead).

R - Drive/reverse gear engaged for backward movement (astern).

T - Engine speed control.

Trim/Tilt Switches- Push top of switch or where indicated to trim out and tilt up, or push bottom of switch or where indicated to tilt down and trim in.

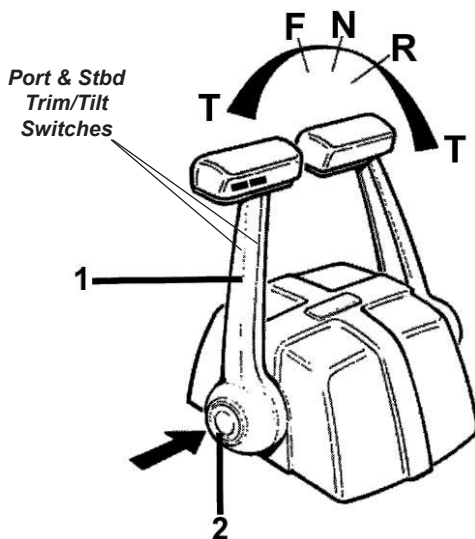

Figure F-3: Dual Binnacle Control Operation

To disengage the shift function:

- 1) Move lever (1) to the neutral position (N).
- 2) Press in button (2), move the lever slightly forward and release the button.

The shift function is now disengaged the lever only effects engine speed. When the lever is moved back to the neutral position it will automatically re-engage the shift function. The shift function is then enabled.

C. Shifting and Control Speed

1. Move shift/throttle lever(s) to the neutral idle position. Placing the shift/throttle levers in the neutral detent position will engage neutral start switch and allow engine to start.

NOTICE

For additional information, refer to the section on "Starting and Operation" in the engine manufacturer's manual.

CAUTION

DO NOT shift into FORWARD or REVERSE unless engine is running. Damage to the shift system could result from trying to shift without the engine running. Carefully check function of all control and engine systems before leaving the dock.

2. To go FORWARD - move the shift/throttle lever(s) forward. Once forward gear engagement is complete, push shift/throttle lever(s) forward until desired speed is achieved.
3. To go in REVERSE - move the shift/throttle lever(s) rearward. Once rearward gear engagement is complete, push shift/throttle lever(s) rearward until desired speed is achieved.

WARNING

DO NOT shift from forward to reverse when the boat is planing.

NOTICE

DO NOT shift if engine speed is above 800 RPM.

4. To go from FORWARD to REVERSE, or REVERSE to FORWARD; always pause at NEUTRAL and allow engine speed to return to idle.
5. After shifting is completed, slowly push throttle lever(s) forward/rearward until desired speed is achieved.

 **WARNING**

Any time the boat is operated, be aware of changes in shift system operation. A sudden increase in shift effort of the shifter levers, or other abnormal operation, indicates a possible problem in the shift system. If this occurs, the following precautions must be taken:

- *With engine running and boat securely tied to the dock, shift drive into forward and reverse to ensure there is gear engagement.*
- *When docking the boat, all docking maneuvers must be performed at slow speed. Pay special attention to other boaters. Passengers should be informed of potential problems and precautions taken.*

If you suspect there is a problem, see your MerCruiser® or Volvo Penta® dealer as soon as possible for proper diagnosis and required service or adjustment. Continued operation could result in damage to the shift mechanism and loss of control.

F - 3 NEUTRAL SAFETY SWITCH

Every control system has a neutral safety switch incorporated into it. This device prohibits the engine from being started while the shift lever is in any position other than the neutral position. If the engine will not start, slight movement of the shift lever may be necessary to locate the neutral position and disengage the safety cutout switch. Control or cable adjustments are required to correct this condition should it persist. See your Four Winns dealer for necessary control and cable adjustments.

F - 4 CONTROL SYSTEM MAINTENANCE

Periodic inspections of the controls, cables, and all connections should be made. Signs of looseness, rust, corrosion, wear, cable jacket cracks or other deterioration require immediate system servicing. Replace all damaged components.

Generally, periodic lubrication of all moving parts and connections with a light, waterproof grease is in order. Cables can be lubricated by positioning them to their fullest extension and applying light grease to the inner cable near the jacket. Working the cables back and forth will distribute the grease in the inner cable. Reapply the grease if necessary.

Lubrication should be performed as often as necessary to keep the system operating smoothly. Cable manufacturers such as Teleflex and Morse often offer special tools to make cable lubrication easier.

Cable and control adjustments may become necessary. Adjustment screws in the control, on the cables and in the linkage are provided.



G - 1 GENERAL

The stern drive Vista® models are equipped with rotary-type steering systems. A tilt steering wheel is standard on the 318 Vista® models.

A. Tilt Steering

The steering wheel can be tilted up or down so as to enhance the driver's comfort and enjoyment. To tilt the steering wheel, depress the release lever with your thumb. See Figure G-1. Be sure to hold the top of the wheel to assist in positioning. Refer to the steering manufacturer's literature for additional information.

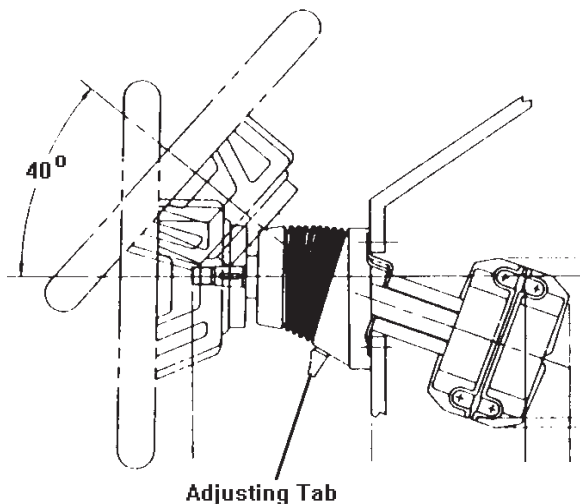

Figure G-1: Tilt Steering

WARNING

The tilt mechanism should not be adjusted when the boat is moving. Sudden boat movement may cause loss of balance resulting in loss of control and/or injury.

WARNING

*The tilt mechanism is spring loaded. Due to the variation in steering wheel offerings, the wheel may spring up rapidly when depressing the release lever. **ALWAYS KEEP ONE HAND ON THE WHEEL DURING TILT ADJUSTMENT OR INJURY MAY OCCUR.***

B. Rotary Steering

In the rotary system, a rotary drum assembly is mounted under the dash behind the steering wheel. A one piece cable runs from the drum assembly through the boat into the engine compartment. At the transom, the cable turns and is connected to the drive tiller and the power steering unit.

C. Power Steering

Power steering is standard engine equipment on stern drive Vista® models. It is comprised of an engine mounted pump, control valve, hoses, and steering cylinder. Power steering works in conjunction with the helm and steering cable to move the transom mounted tiller arm and vertical drive more easily.

On twin engine installations, only the starboard engine is equipped with a power steering hydraulic assist unit. Therefore, when operating on a single engine, it is imperative to operate with the starboard engine. If only the port engine is used, hard steering will result.

NOTICE

***DO NOT** force the steering wheel to either extreme position. This can place undue strain on the unit and can lead to power steering damage.*

Upon commissioning the boat, it is necessary to purge the system of air. This is performed by your Four Winns dealer during pre-delivery service. Should steering difficulty increase with time, it is possible additional bleeding of the system is required. See your Four Winns dealer for assistance. This and other adjustments on power steering units are critical and should be performed only by a qualified service technician.

If the power steering becomes inoperative, steering will be harder and more effort will be needed to steer the boat. Check for a broken or loose belt on the power steering pump. Also, low fluid levels in the power steering pump reservoir will cause hard steering. If these items are not the source of the problem, check for equipment or other items lying on or up against the steering cable at the back of the boat. The cable must be free and clear to slide back and forth. Any item blocking free movement of the cable will result in harder steering and possible damage to the steering cable. If unable to locate or correct the problem, have the steering cable inspected and lubricated by your Four Winns dealer.

CAUTION

After the first two hours of running time, check the entire steering system for loose bolts, nuts and fasteners which could adversely affect steering control.

CAUTION

Steering effort can vary significantly with engine acceleration, steering angle, trim angle, and sea condition. Be prepared for additional steering loads at all times.

NOTICE

Check the fluid level in the reservoir periodically. Low power steering fluid levels may increase steering difficulty.

NOTICE

DO NOT interfere with or restrict steering cable movement through the last 90° of bend at the engine. DO NOT use cable retainers, clamps or tie straps. Using one or all of these could restrict the cable movement near the engine. DO NOT tie wiring harnesses or other control cables to the steering cable. Make sure the deck coaming pads and bulkheads allow for steering cable movement in all positions of trim.

When storing equipment in the engine compartment, be sure to avoid contact with the steering cable. Cables may become kinked or damaged and may increase steering effort.

Additional information on steering operation can be found in Section A-9 in this manual and in your engine owner's manual.

G - 2 STEERING LOAD

A load is placed on the steering system by the propeller torque, and/or water flowing past the outdrives. The steering system is designed to normalize the effort required to turn the steering wheel throughout the average operating speed range and general outdrive position. This is an advantage when the boat is on plane. This can be somewhat of a disadvantage at lower speeds in that the steering effort is not reduced to a level where it can be wheeled "lock to lock" without a concentrated turning effort.

G - 3 PROPELLER TORQUE

The propeller rotation of a single engine operation will exert a directional force on the steering system. This can cause the steering to be harder in one direction than the other, and is called propeller torque.

Propeller torque can also cause the boat to wander (not follow a straight line) when operated at low speeds. This condition is normal and can be corrected only by increasing engine rpm. Wind, water currents and play in steering components can cause equivalent effects.

G - 4 STEERING SYSTEM MAINTENANCE

A periodic inspection of all stern drive steering cables, linkage and helm assemblies should be made. Signs of corrosion, cracking, loosening of fastenings, excessive wear, or deterioration should be immediately corrected. Failure to do so could lead to steering system failure and corresponding loss of control.

The helm and cable assembly should be adjusted so that the steering wheel is centered with the drives in the straight ahead position. There should be an equal number of turns to port and starboard from the straight ahead position. If adjustment becomes necessary, see your Four Winns dealer.

All cables, helm assemblies, and steering connections should be periodically lubricated with a light, water-proof grease or as indicated in the manufacturers information provided in the owner's packet.

H - 1 GENERAL

All electrical equipment on the Four Winns 318 Vista® models operates on 12 volts DC or 120 volts (220 volts on 50 Hertz models) AC electrical power. The 318 Vista® is equipped with a triple battery system along with dockside power (including battery charger) as standard features. Batteries are located in the engine compartment.

 **WARNING**
Fire or Explosion Hazard!

*Electrical system parts are designed by and manufactured to comply with the US Coast Guard requirements to minimize risks of fire or explosion. **Never substitute automotive parts for marine parts.** Automotive parts do not provide the necessary ignition spark protection.*

 **WARNING**

DO NOT tamper with any electrical connection, panel or harness, or attempt installation of any electrical equipment unless thoroughly familiar with the systems and experienced in making such installations.

Circuit breakers are installed on the battery switch to protect various system components. The SHIP SYSTEMS breaker supplies power to all DC electrical components except the aft and forward bilge pumps, ignition, and instrumentation. Additional breakers are located in the cabin circuit breaker panel. The circuit breakers and fuses are labeled for amperage and use.

A helm circuit breaker panel is located underneath the diver's seat. These circuit breakers provide additional protection for certain component wiring which are identified on the panel itself.

H - 2 DUAL ENGINE - TRIPLE BATTERY SYSTEM

Two battery selector switches are installed on dual engine, triple battery installations. This allows DC power to be used from any of the three batteries. Refer to the schematics in the back of the manual.

A. Installation

1. Connect each of the red (positive) battery cables leading from the battery selector switch to the positive (+) terminal on each of the three batteries. Refer to Figure H-1.

NOTICE

Be sure all three red (positive) cables are installed on the positive (+) battery terminals.

2. Connect each of the black (negative) battery cables leading to the engine block to the negative (-) battery terminals on each of the three batteries.

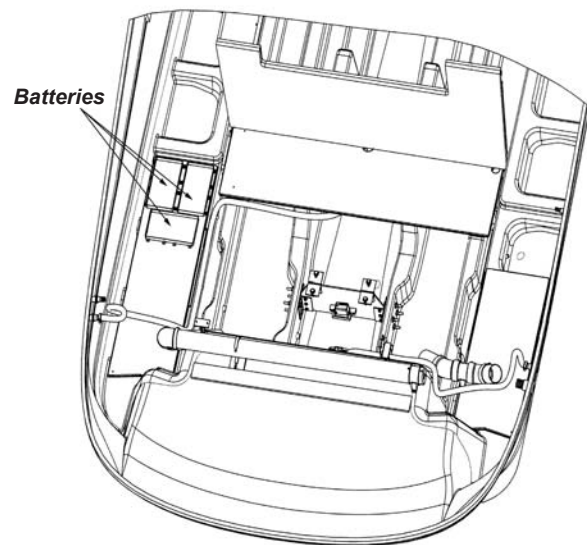

Figure H-1: Triple Battery System

B. Operation

Power to the engines and all 12 volt electrical equipment is controlled at the battery selector panel. On the 318 Vista® models, separate breakers are provided on the battery selector switch panel to protect the stereo, windlass, forward and aft bilge pump, hatch lift, battery outputs, and ship systems.

Battery Selector Switch - Dual

The battery selector switch positions for the dual battery selector switch is as follows:

“OFF” - With the battery selector switches in the “OFF” position and the “SHIPS SYSTEMS” circuit breaker in the “OFF” position, all 12 volt power to the boat is shut off except to the fore and aft automatic bilge pumps, stereo, and windlass. Always turn the battery selector switches and the SHIPS SYSTEMS” circuit breaker

switch to the “OFF” position when the boat is unattended for an extended period.

NOTICE

Twelve volt power to the cabin panel is supplied by the “SHIPS SYSTEMS” circuit breaker on the battery selector panel. This must be turned on to operate any 12 volt accessories on the cabin panel. The bilge pumps, stereo and windlass receive power from the ships system battery and remain on at all time regardless of battery selector or ship systems switch position.

NOTICE

DO NOT turn the battery selector switch to the “OFF” position while its corresponding engine is running. Alternator and wiring damage could result.

Port Engine Battery Switch:

“ON” - Turning the switch to position “ON” will use the port engine battery to power the port engine and 12 volt engine related equipment. The ships system battery will not be used for any engine related equipment, but will power all other 12 volt equipment on the boat. The isolator will allow any alternator to charge all three batteries. “ON” is the recommended switch position for normal boat operation. This position allows maximum use of 12 volt equipment on the boat.

Starboard Engine Battery Switch:

“ON” - Turning the switch to position “ON” will use the stbd engine battery to power the stbd engine and 12 volt engine related equipment. The ships system battery will not be used for any engine related equipment, but will power all other 12 volt equipment on the boat. The isolator will allow any alternator to charge all three batteries. “ON” is the recommended switch position for normal boat operation. This position allows maximum use of 12 volt equipment on the boat.

Emergency Start Procedures:

If one of the designated engine batteries fails to start its respective engine, engage the “EMERGENCY START” switch at the helm and attempt to start the engine. Current is drawn from the other batteries to start the engine. Once engine has been started return the “EMERGENCY START” switch to the “OFF” position. Once back at port, be sure to have the failed

engine battery checked out for possible service or replacement.

H - 3 BATTERY CHARGER

The battery charger is standard on the 318 Vista® models and is located in engine compartment. The batteries will be charged by the battery charger when the boat is connected to dockside power and the AC circuit breakers are “ON”. If a generator is available and operating, it too will allow the batteries to be charged by the battery charger.

Additional information on the battery charger can be found in Section H-8B - 120 Volt AC Equipment in this manual and refer to the manufacturer’s literature included with the owner’s packet.

H - 4 VOLTMETER

Dual gauges with voltmeters are installed in the dash panel to monitor the condition of the engine battery(s). When the voltage is checked during engine operation, the voltage of the respective battery will be indicated on the respective voltmeter. It should be noted that located in the cabin panel is a voltmeter which monitors the “SHIPS SYSTEMS” battery. Additional information on voltmeters may be found in the engine owner’s manual.

H - 5 12 VOLT ELECTRICAL EQUIPMENT

A. Helm Equipment

Ignitions are protected by circuit breakers on the 318 Vista® model. Equipment on the helm is protected by either circuit breakers in the helm and in the cabin’s AC/DC panel.

To assist you, we have listed the descriptions of individual switches, receptacles and their uses:



To prevent electrical problems, use only replacement fuses or breakers that are of equal rating to the originals.

Accessories - Additional 12 volt equipment may be added to the boat by the using the accessory switches. Depending on the model, certain accessories may

be wired directly to the fuse block below the dash or may be wired to a circuit breaker in the AC/DC cabin panel. For additional information on adding accessories, refer to Section H-5B.

12 Volt DC Receptacle - Permits the use of additional 12 volt equipment such as a cell phone. Using the appropriate adaptor, the equipment draws power from the boat's batteries.

Aft Bilge Pump - The BILGE PUMP switch is used to manually activate the bilge pump in the engine compartment. The bilge pump is used to remove water from the bilge (bottom of the hull) area of the boat by pumping that water overboard. The aft bilge pump is equipped with an automatic bilge switch and will operate whenever bilge water rises to a level that will cause the float to move upward.

This automatic bilge pump is active even if the battery selector switch is in the "OFF" position or if no battery selector switch is installed. The automatic bilge pump circuitry is connected directly to the batteries. When leaving your boat unattended for an extended period, check the charge on the battery(s) periodically. Also check the water level in the bilge and make sure the float switch is functional.

If the automatic bilge pump must be disabled, disconnect the wiring plug near the bilge pump.

Blower - The BLOWER switch is used to activate the bilge blower. Pressing the switch to the "ON" position, activates the electric bilge blowers, changing the air in the engine compartment that may contain gas vapors.



Gasoline vapors can explode resulting in injury or death. Before starting the engine, check engine compartment bilge for gasoline or vapors. Operate blower for four minutes, and verify blower operation. ALWAYS run the blower when the vessel is operating below cruising speed.

Cockpit Lights - The COCKPIT LTS switch is used to activate the cockpit (courtesy) lights. An additional cockpit light switch is typically located on the cabin light switch panel.

Horn - To sound the horn, press the HORN switch.

Navigation & Anchor Lights - Moving the NAV/ANC

LTS switch towards the NAV position activates the bow lights, the all-around light and the instrument lights on the dash. Move the switch to the ANC position to activate the all-around light. The center switch position is "OFF".

Arch Lights - The ARCH LIGHTS switch is used to activate the radar arch lights.

Platform Lights - The PLATFORM LIGHTS switch is used to activate the lights for the swim platform.

Engine Lights - The ENGINE LIGHTS switch is used to activate the engine lights in the engine compartment.

Trim Tabs - The boat is equipped with electric-hydraulic trim tabs, the trim tabs are controlled by the TRIM TAB switches. Refer to Section E-8 - Trim Tabs for more information.

Windlass - The WINDLASS switch activates the windlass. A circuit breaker is located on the battery switch panel. Refer to the Section M-12 in this manual and the manufacturer's literature for additional information.

Engine Hatch - The ENGINE HATCH switch is used to raise and lower the engine lid by activating a linear screw jack. Pressing the upper portion of the switch marked "UP" allows the engine lid to be raised. Pressing the lower portion of switch marked "DOWN" lowers the engine lid.

Wiper - The WIPER SELECT switch activates the desired windshield wiper(s). The wiper(s) will self park.

B. Installation of Additional 12 Volt Equipment

Accessories may be added to the boat by wiring directly to the cabin panel. Non-factory installed 12 volt accessory equipment can be connected to the "ACC" switch on the dash.

 **CAUTION**

Be sure to provide proper fuse or circuit breaker protection for all 12 volt equipment that is installed. DO NOT overload the accessory circuitry by installing too much additional 12 volt equipment.

C. Interior Equipment

12 volt cabin equipment will be protected by the 12 volt DC system side of the AC/DC cabin panel. Cabin equipment information is listed as follows:

CO Monitor - The CO monitors are protected by the 12VDC PLUGS circuit breaker in the cabin panel.

Cabin Lights - To turn the overhead lights on, activate the LIGHTING circuit breaker on the 12 volt cabin panel. Use the corresponding CABIN LIGHTS “ON/OFF” switch located on cabin lights panel to activate. Additional cabin light “ON/OFF” switches may be located in various areas of the cabin i.e. forward berthing area.

Forward Bilge Pump - The forward bilge pump can be activated manually by the FWD BILGE PUMP breaker switch placed in the “ON” position. This breaker switch is located on the AC/DC panel.

Any water from the stringers or from other sources within the cabin will drain into the forward bilge compartment. The pump is equipped with an automatic float switch and will operate whenever bilge water rises to a level that will cause the float to move upward. The water will be pumped overboard.

Head Compartment Vent/Blower - A blower is installed in the head compartment. A separate “ON/OFF” switch is provided in the head compartment. The head vent is protected by a “HEAD LIGHT” circuit breaker on the cabin AC/DC panel.

Pressure Water - A pressure water pump delivers water to the faucets, shower, and transom washdown. The pressure water pump will operate automatically as long as the FRESH WATER circuit breaker switch is “ON”. The circuit breaker is located on the AC/DC cabin panel. The fresh water pump is protected by a circuit breaker on the cabin AC/DC panel.

Turn the FRESH WATER circuit breaker switch “OFF” when the water tank becomes empty or when water will not be required for an extended period or when

connected to shore water while at dockside. Tank monitoring systems are available to check water levels. Refer to Section J-1 and J-2 in this manual for additional information.

Cockpit Ice maker or Refrigerator - A circuit breaker is provided on the AC side of the AC/DC cabin panel and on the 12 VDC helm systems breaker panel. The refrigerator has a separate “ON/OFF” switch. Refer to Section L-2 in this manual and to the manufacturer’s literature for additional information.

Stereo - The stereo has a separate switch on the unit and is protected by a circuit breaker labeled STEREO on the 12 volt cabin AC/DC panel.

Sump Pump - A sump pump is used to discharge water from the shower and sink drains overboard. The sump pump has a float switch which will activate the pump when the water level rises in the sump. This pump is protected by the SHOWER SUMP PUMP circuit breaker located in the 12 volt DC system side of the AC/DC cabin panel.

If the boat is equipped with a grey water system, the water from the shower and sinks is pumped into a holding tank instead of overboard.

H - 6 12 VOLT ELECTRICAL SYSTEM SHUTDOWN PROCEDURES

When leaving your boat unattended for an extended period of time it is advisable to shutdown the electrical system to reduce battery drainage and/or possible electrical draw.

To shutdown:

1. Turn the battery switch(s) to the “OFF” position.
2. If your battery switch has a SHIP SYSTEMS circuit breaker switch, move the switch to the “OFF” position.

H - 7 120 (220) VOLT ELECTRICAL SYSTEM

The boat is equipped with 30 amp, 120 volt, 60 Hertz (or 15 amp, 220 volt, 50 Hertz) AC electrical wiring. Depending on the model and when the boat is connected to a shore power outlet, the AC system supplies electrical power to the following items: battery charger, refrigerator, water heater, range, microwave, cockpit icemaker or cockpit refrigerator, outlets, and

air conditioning. The dockside system uses three-wire, color-coded circuitry. The black or hot wire is the ungrounded current carrying conductor. The white or neutral wire is the grounded current carrying conductor. The green wire, referred to as the “equipment ground,” is a grounded conductor, and under normal conditions is not a current carrying wire. The neutral wires are connected together at a buss bar. The equipment grounds are similarly connected together at another buss bar.

Each hot wire is connected to, and protected by, a circuit breaker in the distribution box located at the top section of the AC/DC cabin panel identified “120V AC SYSTEM”. The standard dockside system has a main circuit breaker which protects the overall distribution network. The MAIN dockside inlets are located in the aft transom systems locker. The 318 Vista® models have MAIN circuit breakers on the AC/DC cabin panel. The MAIN breakers must be turned “ON” and the boat must be connected either to shore power or generator running for AC system operation. The MAIN circuit breakers protects both the hot and neutral input leads. This breaker is sensitive. The resulting power surge which occurs when connecting the shore power cord may cause the MAIN breakers to trip. To avoid this power spike, turn off the MAIN breakers before plugging in the shore power cord. Securely connect the power inlet of the boat and the shore power receptacle. Once the shore power is securely connected, turn the MAIN breakers back on. If the connection is broken and later re-secured, the circuit breaker may trip. Connections must be secure for uninterrupted dockside service.

The AC voltage for the generator, or shore power AC systems 1 or 2, may be monitored with the AC voltmeter in the AC/DC panel. Use the AC source toggle switch to monitor the voltage of the system desired.

H - 8 DOCKSIDE OPERATION

 **WARNING**

If any abnormalities appear during dockside operation, DISCONNECT the system immediately to prevent electric shock hazards! Have the boat's electrical system and the shoreside receptacles checked as soon as possible.

A. Shore Power Connections

 **WARNING**

To prevent electric shock hazards, use only equipment with approved three wire electrical plug connections. Be sure each item being used has been tested and is free of electrical shorts and ground faults.

Fifty foot, ten gauge, three-wire, shore power cords are provided with dockside wiring. The shore power cords on 60 Hertz systems have 30 amp twistlock-type connectors. They have a power “ON” indicator light to ease in connecting and troubleshooting. This connector complies with the American Boat and Yacht Council (ABYC) standards.

Some marinas are not equipped with approved twistlock-type receptacles. An adaptor is available from Four Winns which converts the twist-lock shore plug to a three-wire grounded household type plug. Use only an approved adaptor when an adaptor is necessary.

 **WARNING**

DO NOT use a two-wire adaptor to connect to a three-wire system. These adaptors do not provide adequate grounding.

Shore power connection procedure is as follows:

1. Turn off the boat's main breaker switch before connecting or disconnecting the shore power cable.
2. Connect shore power cable to the dockside inlet receptacle of the boat first, then connect it to dockside shore power outlet.

NOTICE

Always connect the cord to the power inlet receptacle of the boat before making connections to the shore power source.

3. Check for reversed polarity on the AC panel. If the reversed polarity light is activated, immediately disconnect the shore power cord. See Section H-8C - Reverse Polarity Indicator.

- To disconnect shore power, turn off the main breaker switch on the AC electrical panel and disconnect the power cord from the shore power dockside receptacle first. Then, disconnect the cord from the boat.

NOTICE

Always disconnect the shore power cord from the dockside first before disconnecting from the boat.

NOTICE

Always remember to disconnect the shore power cord from the dockside first before leaving the dock. Properly store shore power cord.

B. 120 Volt AC Equipment

All 12 volt equipment is isolated from the 120 volt AC system (except the refrigerator which is dual voltage). Appropriately labeled circuit breakers protect all AC systems on the boat. The receptacles can be used for 120 volt (220 volts on 50 Hertz models) household appliances. Refer to the following list for information on appliances and other equipment.

Battery Charger - The battery charger is controlled by a circuit breaker on the AC electrical panel in the cabin labeled BATTERY CHARGER. In order for the charger to charge the battery(s) the circuit breaker must be "ON" while connected to dockside power. If a generator is available and operating it too will allow the batteries to be charged by the battery charger.

Refrigerator - The GALLEY REFRIGERATOR circuit breaker must be on to operate on 120 voltage. If this breaker is off, the refrigerator will automatically operate on the 12 volt system. This can deplete the battery. Excessive drain on the battery may cause irreparable battery damage. The refrigerator will automatically operate on 120 volts when provided. Refer to Section L-1C - Galley Equipment in this manual for more information.

Water Heater - The WATER HEATER circuit breaker supplies power to the water heater. Refer to Section J-2C - Water Heating Systems in this manual for more information.

NOTICE

DO NOT supply electrical power to an empty water heater. Activate the FRESH WATER circuit breaker and switch to start the water pump and prime the system. Be sure there is adequate water in the system before turning on the water heater. Failure to comply will result in immediate damage to the heater element.

Electric Stove - The RANGE circuit breaker must be activated to supply power to the electric stove. Refer to Section L-1A - Galley Equipment in this manual for more information.

Microwave - The MICROWAVE breaker must be activated and the boat connected to dockside power or use the generator to supply power to the microwave.

Icemaker - The icemaker is standard on the 318 Vista® models. The COCKPIT ICEMAKER/REFRIGERATOR breaker located on the AC side of the AC/DC cabin panel must be "ON" to supply power to the icemaker.

Receptacles - The OUTLETS circuit breakers supply power to the corresponding receptacles in the AC system.

Air Conditioner - The AIR CONDITIONER circuit breaker supplies power to the air conditioner. The 318 Vista® models have dual dockside installation. With a dual dockside installation, one inlet is dedicated to the air conditioning only and the other is for the "AC Main Inlet". Refer to Section L-4 - Air Conditioning in this manual for more information.

Most receptacle circuits are capable of handling 15 amperes. Refer to Table III for a list of equipment and the electrical currents usually required to operate these items. For 220 volt, 50 Hertz models, divide all of the current ratings by 2. Usually, the power requirement is specified on the electrical item. This is only an approximation of the electric current usage normally experienced.

EQUIPMENT	ELECTRICAL LOADS
Air Conditioners	See motor load plate
Battery Chargers	Up to 800 watts (7.3 amps)
Blankets (Electric)	50 to 200 watts (2 amps)
Coffee Makers	550 to 700 watts (6.3 amps)
Electrical Drills	See motor load plate
Fans	25 to 75 watts (0.7 amps)
Fry Pan	1350 watts (12.3 amps)
Heater	1500 watts (13.7 amps)
Lights	Wattage as marked
Television	1500 watts (10.5 amps)
Vacuum Cleaners	See motor load plate

Table III: Electrical Equipment

C. Reverse Polarity Indicator

Improper grounds or reversed polarity at shore power are a source of serious electrical hazard. The reverse polarity light will indicate if a problem exists at the 120 AC electrical system shore connection.

If a problem exists, the reverse polarity indicator light will come on when the shore power cable is attached to the inlet. **DO NOT** activate the shore power switch in the cabin when the reverse polarity light is on.



ALWAYS check the reverse polarity indicator light in the AC distribution panel immediately upon connecting the shore power cord before turning on the AC SHORE POWER circuit breaker. If the light is on, a problem with a reversed electrical connection exists. Disconnect the shore power cord immediately. Notify the marina and have the dock's shore power connection inspected.

Under proper operating conditions, the reverse polarity indicator light **will not** be on. A green light is provided for the shore power and will be "ON" when dockside power is being used.

NOTICE

Some marina shore power systems may be improperly grounded to retard electrolysis (see Section H-11 - Stray Current Corrosion). Before using any 120 volt equipment, make sure the reverse polarity light does not activate when connecting the cord to the inlet.

D. Ground Fault Current Interrupters (GFCI)

The ground fault current interrupter (GFCI) is a device which protects against hazardous electrical shock from improper ground. An appliance electrical cord with worn insulation or damp equipment may have stray current which will run through electrical grounds. Stray current as above will result in an electrical shock.

One GFCI receptacle will protect all of the receptacles on the circuit. A GFCI may be used as a receptacle as well as an interrupter.

To test:

Push the black test button and the red reset button should pop out from the inner surface. The receptacle and the circuit are now off.

Push the reset button in until it clicks to reset it. If it does not reset, there is either a short in the circuit or the equipment being used, or a ground fault in the equipment. Unplug all appliances and reset the GFCI. One at a time, plug the equipment back in and turn it on. The item that causes the GFCI to trip is the problem item and should **not** be used.

H - 9 GENERATOR

A generator is optional on the 318 Vista® models. It provides 120 Volt (220V) AC power when the boat is away from the dock. The generator can be operated while running at or below cruising speed. The generator should not be operated when the boat is being run at high speeds. **Insufficient cooling water may be available due to the speed.**

A generator factory installed by Four Winns is capable of providing sufficient power for most electrical needs including cooking, refrigeration, and air conditioning. **It is possible to overload the generator by trying to operate too much equipment at one time.** The circuit breaker that protects the output circuits on the generator set will trip should that occur. See the generator manufacturers information for specifications and additional details.

If you wish to use dockside power, be sure the generator is off, connect the shore power cords as explained in Section H-8A, and turn on the Shore Power breakers on the AC cabin panel. If you wish to use generator power:

1. Be sure the shore power cord(s) are disconnected.
2. Check the bilge for fumes, operate the blower for at least 4 minutes, and verify blower operation.
3. Open the generator's seacock valve (labeled GENERATOR) to allow water flow to the generator for cooling purposes.

NOTICE

In order to use the generator, you must first open the seacock valve (handle parallel to the flow of valve). Failure to open seacock valve while running generator will cause generator to overheat and possible failure. When not using the generator be sure to close the seacock.

4. Start the generator using the remote generator start switch on the AC/DC cabin panel.
5. Turn on the generator's main breakers located in the AC cabin panel.

WARNING

Be sure to operate the bilge blower for at least four (4) minutes before starting engine or generator, or whenever operating the engine(s) at idle speed. Check the bilge blower output before each use.

WARNING

Generator exhaust contains carbon monoxide. Review information regarding carbon monoxide at Section B-2 - Carbon Monoxide and Section E-2 - Engine Exhaust.

Periodic generator maintenance as outlined in the generator owner's manual is necessary. Refer to the manufacturer's literature for more information. General generator installation diagrams are included at the end of this section.

H - 10 ELECTRICAL SYSTEM MAINTENANCE

A. Battery Maintenance

Be sure to keep the batteries charged. Also, keep the batteries clean, especially the terminals and connection lugs. Be sure the batteries are fastened securely while in use.

Check the battery fluid level often, especially when a charger/converter is being used. Replenish a battery indicating a low charge. Determine the reason for the discharge. Lack of battery usage is as detrimental to battery longevity as is overuse. Alternating battery usage is important. Refer to the battery manufacturer's instructions included with your battery.

DANGER

Batteries produce hydrogen and oxygen gases when being charged. These explosive gases escape through the vent/fill caps and may form an explosive atmosphere around the battery if the ventilation is poor. This gas may remain around the battery for several hours after charging. Sparks or flames can ignite the gas and cause an explosion.

WARNING

Fire or Explosion Hazard!

Only qualified personnel should install batteries and perform electrical system maintenance. Do not expose batteries to open flame or sparks. Do not smoke near batteries.

WARNING

Poison!

Sulfuric acid in batteries can cause severe burns. Avoid contact with skin, eyes, or clothing. Wear goggles, rubber gloves and protective apron when working with batteries. In case of skin contact, flush with water at least 15 minutes. If swallowed, drink large quantities of water or milk. Follow with Milk of Magnesia, beaten egg or vegetable oil. Get medical attention immediately.

 **WARNING**

Disconnect the battery before working on electrical or ignition system to prevent electrical shock and accidental ignition.

B. Electrical Wiring Maintenance

Periodically, inspect all wiring for nicks, chaffing, brittleness, improper support, etc. Examine the shore power cord closely for insulation cracks and corrosion in the electrical devices. Spraying the receptacles and electrical connections with an electrical connection cleaner will reduce corrosion and improve electrical continuity.

 **WARNING**

DO NOT allow corrosion to build up on connections. Shorts or ground faults can result.

The entire 120 (220) volt circuitry, especially the shore power cord, should be seasonally tested for proper continuity by an experienced marine electrician. This will help detect any short, open wire, or ground fault. Also, check the polarity indicator system for proper operation.

 **WARNING**

120 (220) volt AC electrical power can be dangerous. DO NOT attempt to service a system unless you are familiar with, and experienced in, performing such service.

H - 11 STRAY CURRENT CORROSION

A. General

Electrically induced underwater corrosion occasionally affects boats and their related components. This is referred to as “Stray Current Corrosion” and appears as surface pitting or deterioration. Stray current corrosion is the decomposition of chemical compounds by electric current.

Stray current corrosion can be caused by surrounding boats; an improperly wired battery/charger installation or other boats that are in close proximity which have electrical power leakages. Stern drive units are especially vulnerable to stray current corrosion.

Periodically inspect the engine components to determine if corrosion damage exists. If stray current corrosion damage is found, determine and correct the cause of the stray current to prevent further damage. Consult an experienced marine electrician or contact your Four Winns dealer for assistance.

The use of some shore power battery chargers, while the boat is in the water and the battery is connected to the system, can cause stray current corrosion. Have an experienced marine electrician review any battery charger installation to ensure a stray current corrosion problem will not develop. An improper battery connection is a common cause of stray current corrosion.

NOTICE

Use only UL Marine-ignition protected battery charger(s) designed to meet US Coast Guard regulations for external ignition protection.

Corrosion is usually more prevalent in polluted or salt water than in fresh water. It is also more likely to occur when dockage is in an area with steel piers, large metal boats, or where shore power is in use.

B. Galvanic Corrosion

Galvanic corrosion results from a potential electrical difference existing between dissimilar metals immersed in a conductive solution (e.g., salt or brackish water). If these metals touch or are otherwise electrically connected, this potential difference produces an electron flow between them. The attack on the more active metal is usually increased and the attack on the less active metal is decreased, as compared to when these metals are not touching.

C. Corrosion Prevention

Anticorrosion anodes are attached to the bottom of the gimbal housing of your stern drive to prevent corrosion to your electrical systems and underwater parts. These anodes will be slowly eroded away by galvanic action and require periodic inspection. Please refer to the section on “Anti-Corrosion Anodes” in your engine manufacturer’s manual for additional information.

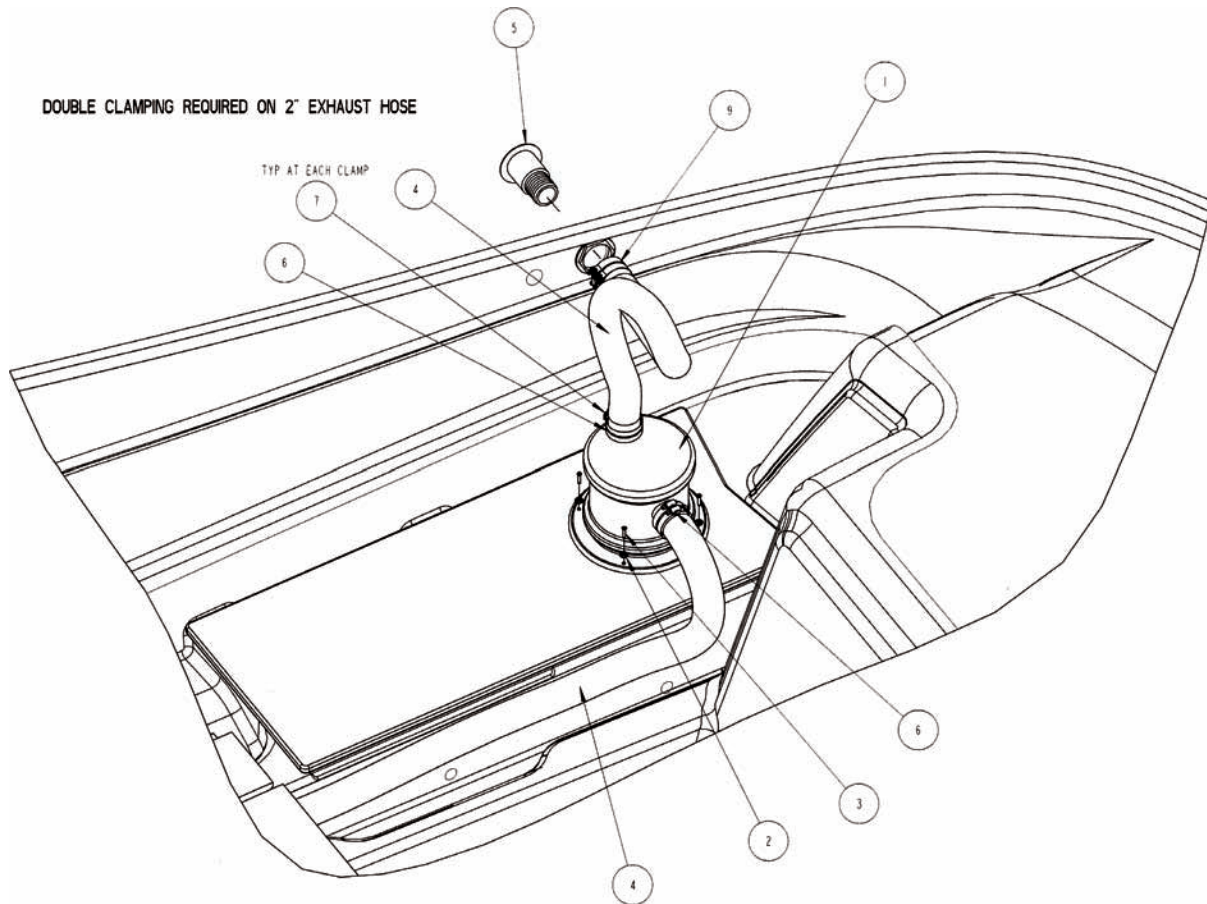
FIGURE H-2: 318V GENERATOR OPTION (1 OF 3)

#	DESCRIPTION	PART No.	QTY	U/M
1	MUFFLER, KOHLER GENERATOR 1500026	032-0388	1	EA
2	WASHER, FINISH #8 SS FLANGE WFFSS8	080-0091	4	EA
3	SCREW, #10 x 1" POHSMS	080-0035	4	EA
4	HOSE, 2" EXHAUST	022-0037	15	FT
5	THRU-HULL, 2" S.S.	035-0792	1	EA
6	CLAMP, 2" EXHAUST	021-0097	6	EA
7	BOOT, HOSE CLAMP	030-0864	6	EA
* 8	CAULK, 1/4" BEAD BELOW WATERLINE	084-0175	A/R	
9	CLAMP, 2-1/2" T-BOLT #70STBC250	021-0516	2	EA

***NOT SHOWN**

FIGURE H-3: 318V GENERATOR OPTION (2 OF 3)

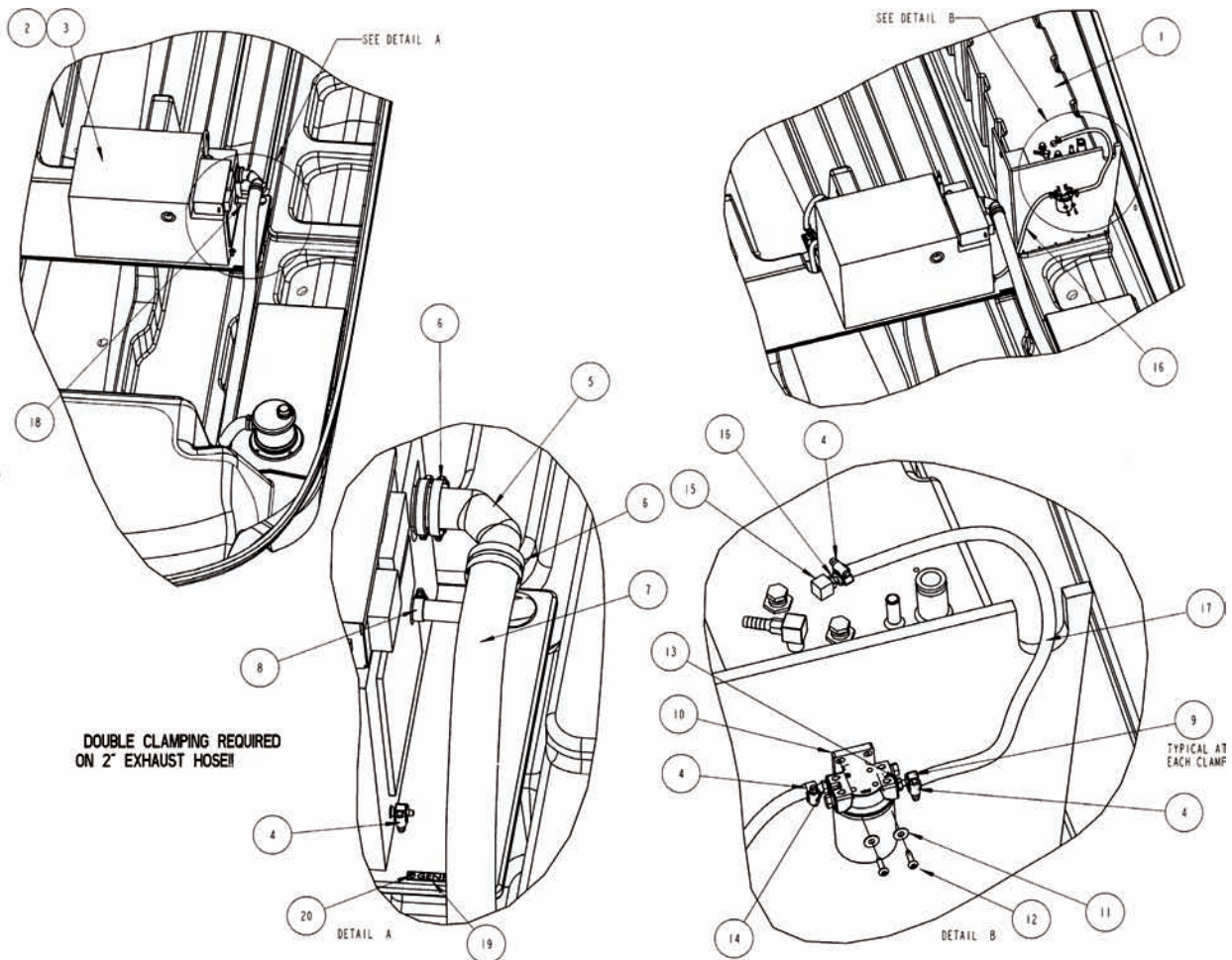

#	DESCRIPTION	PART No.	QTY	U/M
1	TANK, FUEL, STBD, 85 GAL., 308V *05*	020-0340	REF	
2	GENERATOR, 5KW KOHLER SE-E 120V	065-0998	1	EA
3	SCREW, #14 x 1" PPHSMS	080-0940	6	EA
4	CLAMP, 3/8" HOSE #67065-52	021-0034	4	EA
5	ELBOW, EXHAUST 90 DEG.	030-1684	1	EA
6	CLAMP, 2" EXHAUST	021-0097	4	EA
7	HOSE, 2" EXHAUST	022-0037	REF	
8	CLAMP, 5/8 INCH #10H FUEL VENT	021-0031	1	EA
9	BOOT, HOSE CLAMP	030-0864	10	EA
10	FILTER, FUEL/WATER SEPERATOR	021-0433	1	EA
11	WASHER, .255 X .750 X .070 FLT	080-0214	2	EA
12	SCREW, #14 x 1" PPHSMS	080-0940	2	EA
13	HOSE BARB, 1/4 NPT X 1/4" ID	021-0398	1	EA
14	HOSE BARB, 1/4MP TO 3/8HB #220EE	021-0014	1	EA
15	PICK-UP, GENERATOR 11"	021-0289	1	EA
16	VALVE, ANTI-SIPHON 1/4" MPT X 1/4" HB	021-0467	1	EA
17	HOSE, 1/4" ID FUEL FEED	021-0079	14	FT
18	HOSE, HW WATER 3/4"	022-0201	12	FT
19	PLATE, GENERATOR	056-0114	1	EA
20	SCREW, #8 x 1/2" PPHSMS BLACK	080-0024	2	EA

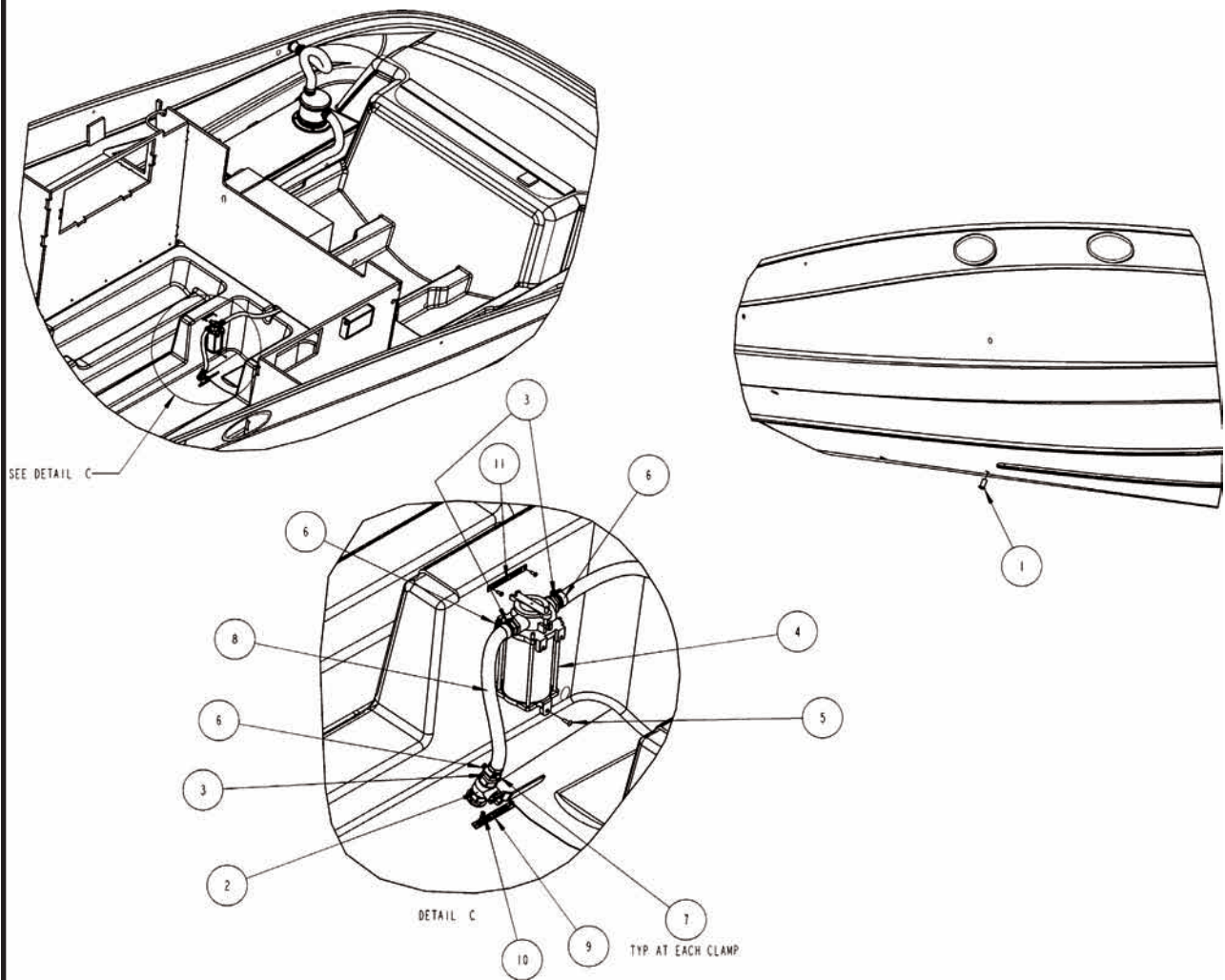
FIGURE H-4: 318V GENERATOR OPTION (3 OF 3)

#	DESCRIPTION	PART No.	QTY	U/M
1	THRU-HULL, 3/4" BRONZE	035-0552	1	EA
2	VALVE, BALL 3/4"	035-0118	1	EA
3	HOSE BARB, 3/4 MPT X 3/4 HB	035-0327	3	EA
4	STRAINER, WATER 3/4"	035-0248	1	EA
5	SCREW, #10 x 3/4" PTHSMS	080-0033	3	EA
6	CLAMP, 5/8 INCH #10H FUEL VENT	021-0031	3	EA
7	BOOT, HOSE CLAMP	030-0864	3	EA
8	HOSE, HW WATER 3/4"	022-0201	REF	
9	PLATE, GENERATOR SEAWATER	056-0103	1	EA
10	SCREW, #8 x 1/2" PPHSMS BLACK	080-0024	4	EA
11	PLATE, GENERATOR STRAINER	056-0104	1	EA
# 12	CAULK, 1/4" BEAD BELOW WATERLINE	084-0175	A/R	

I - 1 GASOLINE FUEL SYSTEMS

Gasoline fuel systems used in Four Winns® boats are designed to meet or exceed the requirements of the US Coast Guard, the National Marine Manufacturers Association, and the American Boat and Yacht Council in effect at the time of manufacture.

NOTICE

Use only clean, dry fuel of the type and grade recommended by the engine manufacturer. The use of incorrect or contaminated fuel can cause engine malfunction and serious damage. Engine damage resulting from the use of a lower octane gasoline is considered misuse of the engine and will void the engine warranty. Refer to the section on Gasoline Requirements in the engine manual for information on octane specifications.

In twin engine applications, the port and starboard fuel tanks are located forward and outboard in relationship to their respective engine. See Figure I-1. The capacity of the fuel tank(s) may be found on our website at www.fourwinns.com.

The 318 Vista® models are equipped with twin fuel tanks and come with a manual fuel valve system. See Figure I-2. This fuel valve system allows you to manually select which fuel tank you want your engines to draw fuel from. The generator (if applicable) uses a separate fuel pick-up. Please see Figure I-8 at the end of this section for fuel valve operations.

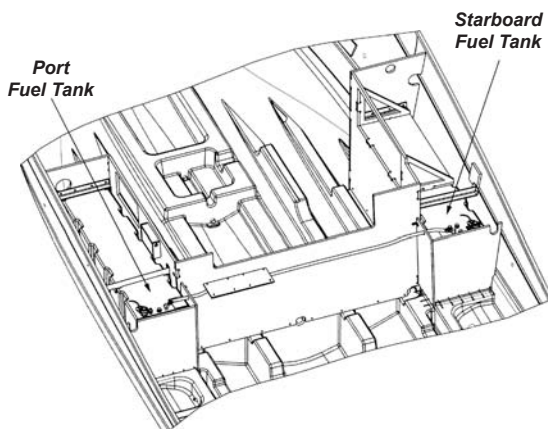

Figure I-1: Twin Fuel Tank Locations

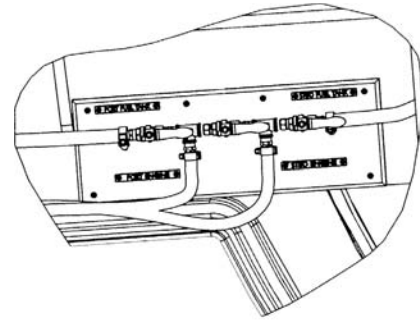

Figure I-2: Fuel Valve System

A. System Testing

All gasoline fuel systems have been factory inspected and pressure tested in accordance with regulations in effect at the time of manufacture. Additionally, each fuel tank must pass rigid tests and inspections performed by the fuel tank manufacturer.

Prior to taking delivery, it is important that a full inspection be made of the entire fuel system by the selling dealer. An entry on the Four Winns Pre-Delivery Inspection Form portion of the Warranty Registration Card will attest to the dealer's performance of this service.

B. Fuel Fills

The fuel fill deck plates are located on the port and starboard rear decks and are marked "GAS". See Figure I-3. Be sure to utilize the proper type and grade of fuel as recommended by the engine manufacturer. To open, insert the deck plate key into the holes on the cap and rotate counterclockwise. A bead chain connects the cap to body to help prevent loss overboard. Refer to Section I-3 for information regarding fueling instructions.

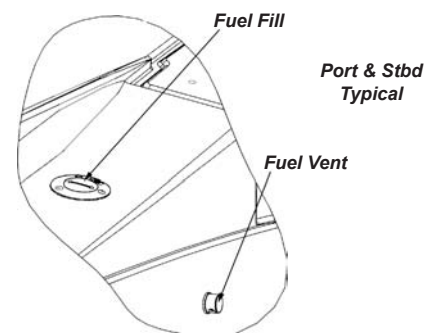

Figure I-3: Fuel Fill & Fuel Vent

WARNING

DO NOT confuse FUEL deck fill plate with WATER or WASTE deck plates. Deck fill plates are labeled according to the intended use.

The gasket/O-ring seals on the fuel fill cap assist in sealing when closed. A missing or damaged O-ring can allow water on the surrounding surfaces to run into the tank.

Periodically inspect the cap and the fuel deck plate. The O-ring seal should be inspected for cracks or damage and replaced as necessary. Lubricating with a light, waterproof oil or grease is recommended and can extend the O-ring's longevity.

C. Fuel Vents

On the 318 Vista® separate thru-hull fuel vents are installed. See Figure I-3. While the tank is being filled, the air displaced by the fuel escapes through the vent overboard.

WARNING

Spilled fuel is a fire and explosion hazard. DO NOT overfill or overflow the tank, or allow fuel spills into the hull or bilge. If spillage occurs, clean up immediately and dispose of soiled rags/towels in a proper container.

WARNING

*Avoid overboard spills. When tank is almost full the sound from the fuel vent will change. The pitch will become higher indicating the tank is close to being full. Stop pumping fuel into tank. **Do not top off.***

NOTICE

When fueling at a marina, DO NOT overfill. Fuel may spill into the water.

After fueling, replace the fill cap, and wash the areas around the fuel fill plate and below the fuel vent. Residual fuel left on the deck and hull sides can be dangerous, and will yellow the fiberglass. It will also damage the tape stripes and logos.

For those models with thru-hull venting, periodically, inspect the fuel vent(s) for any dirt, wax, etc. Carefully

remove any obstruction with a pipe cleaner or similar device. **Be sure not to puncture the screen.** The vent screens are designed to keep insects and foreign matter from contaminating the fuel and fuel system. The stainless steel cap is not removable.

D. Anti-Siphon Valves

The fuel withdrawal line is equipped with an anti-siphon valve where the line attaches to the fuel tank. The valve prevents gasoline from siphoning out of the fuel tank should a line rupture. See Figure I-4 for anti-siphon location.

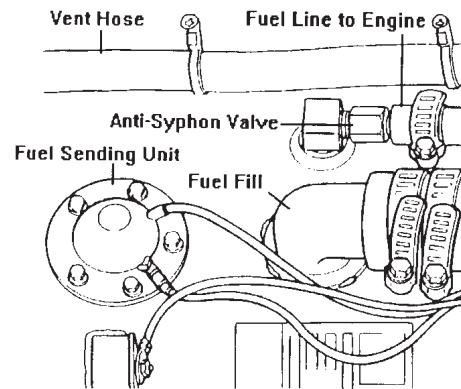

Figure I-4: Fuel Tank Fittings

CAUTION

DO NOT remove the anti-siphon valve(s) from the system. Should the valves become clogged, clean and reinstall or replace.

CAUTION

The fuel withdrawal is positioned in the fuel tank to achieve optimum fuel usage, and fuel line routing. At certain speeds and hull trim angles, the fuel supply at the withdrawal can increase or decrease accordingly. Be extremely careful when attempting to operate the boat on a minimum amount of fuel. Though some fuel may be in the tank, the relative trim angle of the boat may cause the fuel to flow away from the withdrawal.

NOTICE

On all Vista® models, access to the anti-siphon valve and fuel sender is by either an access plate or through the engine compartment.

E. Fuel Gauge

The fuel gauge indicates the amount of fuel in the fuel tank. See Section E-9F - Fuel Gauge for additional information on fuel gauge use.

F. Fuel Senders

The fuel sender consists of a float which travels up and down a stationary tube. The float measures the level of the fuel in the tank and sends a signal to the fuel gauge. See Figure I-5.

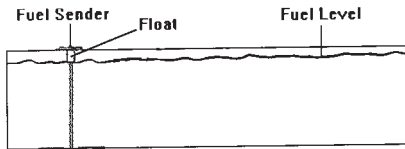

Figure I-5: Fuel Sender Operation

Due to the mechanical nature of the fuel sender, variations in readings during various speeds of operation may occur. This system is merely a relative indication of the available fuel supply and not a calibrated instrument. With this type of sending unit a more accurate measurement of fuel level is obtained with the boat in a level position.

The gauge readings will also vary with the trim angle of the boat. When sitting at a dock and the boat is nearly level, the fuel gauge will register accurately. Refer to Figure I-3. When boating, the trim angle of the boat changes and affects the gauge readings. Under these conditions, the fuel sender will register “full” for the first few hours of running time until the fuel level drops below the 3/4 or 1/2 mark. This is caused by the angle of the fuel in the tank as shown in Figure I-6.

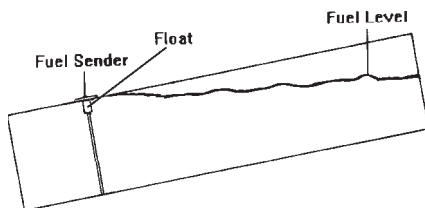

Figure I-6: Effects of Trim Angle

It is very important to keep track of hours and fuel consumption to obtain an average gallon per hour consumption figure. Refer to the fuel log located at the back of this manual. This will prevent any problems with running out of fuel on the water.

Dealers are equipped with some general figures on consumption which can be used as a guide until specific information on your boat is determined. Because of boating conditions, speed, weight and other factors common to your situation, fuel consumption will vary between your boat and consumption figures developed by Four Winns. When the fuel gauge begins to register below the “full” mark, the gauge readings will drop much faster until it reads “empty”. When this occurs, the trim angle has affected the sender reading. When the gauge registers “empty”, the sender has bottomed out and there may be 3 to 4 gallons of fuel in the tank. See Figure I-7.

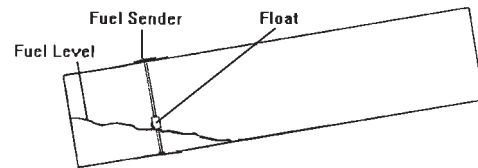

Figure I-7: Trim Angle Effect with Low Fuel

G. Fuel Filters

Fuel filters are installed on each engine. Filters should be changed frequently to assure an adequate supply of fuel to the engine. Refer to the engine manual for additional information. The engine manual is included in the owner’s information packet.

NOTICE

Canister-type filters should be changed annually.

H. Gas Vapor Detector

A gas vapor detector is optional on the 318 Vista® models. The gas vapor detector will monitor the engine compartment and notify the operator of an accumulation of gasoline vapors. The operator must take immediate action upon warning to avoid the possibility of an explosion.

The sensing unit is usually mounted towards the rear of the engine compartment. The alarm unit is mounted at the dash.

⚠ WARNING

Always personally inspect the engine compartment and sniff for fuel vapors before starting the engine. Remember, a gas vapor detector is a mechanical device. DO NOT rely exclusively on its operation.

I. Use and Maintenance**⚠ WARNING**

DO NOT let the odor of gasoline go unchecked. If the odor of gasoline is noted, DO NOT START ENGINE. If engine is running, SHUT OFF ENGINE, ELECTRICAL AND HEAT GENERATING EQUIPMENT. Investigate and correct the situation immediately! Have all passengers put on personal flotation devices and keep fire extinguishers at hand until the situation is resolved.

⚠ WARNING

Avoid serious injury or death from fire or explosion resulting from leaking fuel. Inspect system for leaks at least once a year.

If areas are found within the fuel system that appear questionable, have a qualified marine technician inspect the system. A thorough fuel system examination should be made by an experienced marine technician at least once a year.

⚠ WARNING

To help guard against damage, avoid the storage or handling of gear near the fuel lines, fittings and tanks.

I - 2 FUEL STANDARDS

Be cautious when using gasoline which contains alcohol.

⚠ CAUTION

To conform to Federal Air Quality Standards, the petroleum industry reduced the amount of tetraethyl lead in gasoline. Alcohol is being blended with gasoline to help restore the octane rating lost when the lead was removed. While blending alcohol with gasoline increases the octane level of the fuel, it can also create certain safety and performance related problems for boaters.

A. Problems With Alcohol In Gasoline

Below is a list of problems which may be experienced when using blended gasoline.

1. Premature deterioration of fuel system components may occur. Alcohol will attack rubber fuel hoses, fuel tanks, fuel filters, fuel pumps and rubber gaskets. This deterioration will lead to fuel system leakage.
2. Phase separation of fuel will cause contamination. Water which accumulates in the tank through contamination or condensation will be absorbed by the alcohol. This water-heavy alcohol will settle at the bottom of the tank. This phase separation will lead to fuel tank corrosion. This may also result in a lean mixture to the carburetor and cause engine stalling or possible engine damage.

The use of alcohol additives in gasoline has become more widespread. Regulations on public notification of the existence of additives is currently controlled by the Environmental Protection Agency (EPA). Some states do require that gasoline pumps display information on additives (especially alcohol). If alcohol content is not posted, ask and avoid using fuel containing alcohol if possible.

B. Recommendations

Assume blended gasoline is being used and follow these recommendations below.

1. Inspect fuel hoses often. A deteriorated hose containing alcohol blended gasoline will normally be soft and swollen. A deteriorating hose containing no fuel will normally be hard and brittle. In both cases the hose should be replaced.
2. Ventilate the engine compartment before starting the engine(s). Operate the engine compartment

blower for four (4) minutes. Then, prior to starting the engine(s), check the bilge area for the scent of gasoline fumes; **DO NOT** start the engines if the odor of gasoline is detected.

3. Frequently inspect the fuel system fittings. Inspect the fuel tank, pump and filter for signs of leaks or corrosion. Visually inspect for deteriorating metal fittings at the fuel hose connections.
4. If areas are found within the fuel system that appear questionable, have a qualified marine technician inspect the system. Have those fuel system components that do not pass inspection replaced. A thorough fuel system examination should be made by an experienced marine technician at least once a year.

I - 3 FUELING INSTRUCTIONS

1. Avoid fueling at night except in emergencies.
2. When moored at fueling pier:
 - a. Do not smoke, strike matches, or throw switches.
 - b. Stop all engines, motors, fans, and devices that could produce sparks.
 - c. Put out all lights and galley stove.
 - d. Position the Battery Selector Switch to OFF.
3. Before starting to fuel:
 - a. Ensure that boat is moored securely.
 - b. Close all ports, windows, doors and hatches.
 - c. Be sure the proper type of grade of fuel as recommended by your engine manual is used.
 - d. Determine how much additional fuel is required to avoid overflow.
4. During fueling:

Keep the fill nozzle in contact with the fuel opening at all times to guard against possible static spark. See Figure I-8.

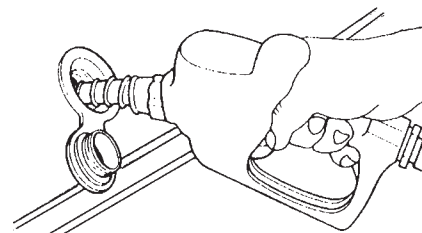

Grounding the fuel hose - Proper

(Nozzle in contact with fuel opening - Correct)

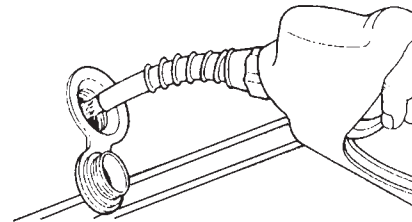

Not grounding the fuel hose - Improper

(Nozzle not in contact with fuel opening - Incorrect)

Figure I-8: Grounding Fuel Hose

WARNING

*Spilled fuel is a fire and explosion hazard. DO NOT overflow the tank or allow fuel spills into the hull or bilges. Avoid overboard spills. When tank is almost full the sound from the fuel vent will change. The pitch will become higher indicating the tank is close to being full. Stop pumping fuel into tank. **Do not top off.***

5. After fueling:
 - a. Replace all fill caps securely.
 - b. Wipe up any spilled fuel.
 - c. Open all ports, windows, doors and hatches.
 - e. Determine that there is no odor of gasoline in the engine compartment or below decks before starting machinery, turning on lights or lighting stove. Operate the bilge blower system for at least four (4) minutes before engine start-up.
 - f. Be prepared to cast off moorings as soon as engines are started.

NOTE: GENERATOR OPTION HAS SEPARATE FUEL PICK-UP.

(NOTE: GENERATOR OPTION HAS SEPARATE FUEL PICK-UP.)

PORT ENGINE AND STARBOARD ENGINE DRAWING FROM BOTH FUEL TANKS.

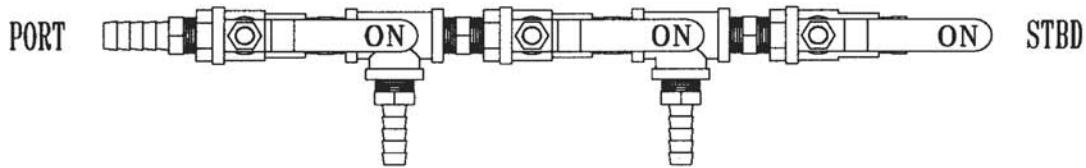

FUEL SYSTEM COMPLETELY CLOSED.

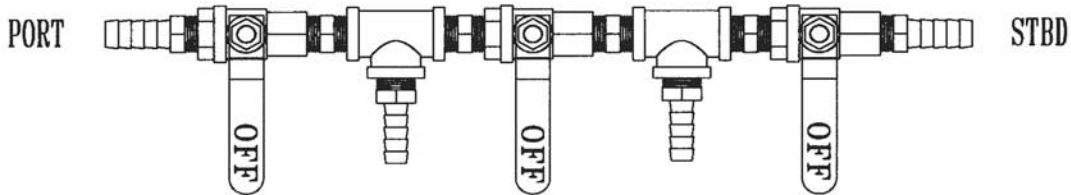

PORT ENGINE AND STARBOARD ENGINE DRAWING FROM STARBOARD FUEL TANK.

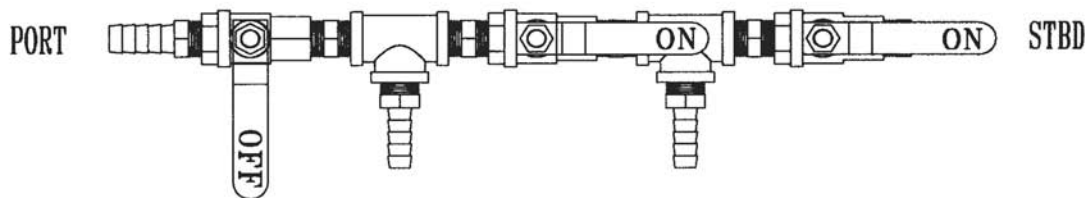

PORT ENGINE AND STARBOARD ENGINE DRAWING FROM PORT FUEL TANK.

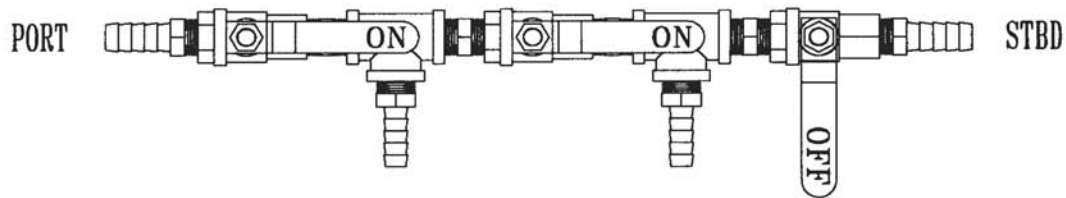

- 1) PORT ENGINE DRAWING FROM PORT FUEL TANK.
- 2) STARBOARD ENGINE DRAWING FROM STARBOARD FUEL TANK.

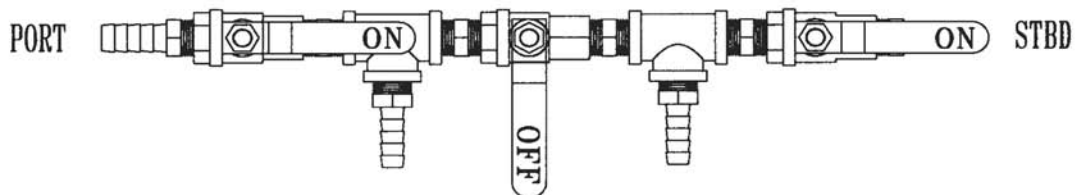

Figure I-8: Fuel Valve System

J - 1 GENERAL

All Four Winns Vista® models are equipped with a fresh water supply system. This system consists of a water supply tank, water distribution lines and a distribution pump. The water fill deck plate for the fresh water system is located on the deck and labeled accordingly. Always fill the tank slowly. See Figure J-1.

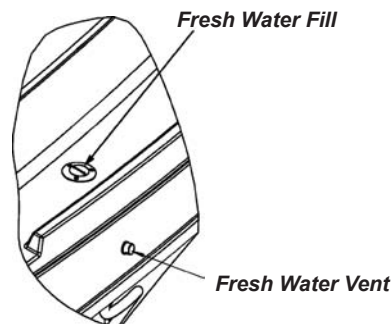



Figure J-1: Fresh Water Fill & Vent

CAUTION

The water deck plate is appropriately labeled. DO NOT fill the system with anything other than water. Should the system become contaminated with fuel or other toxic solution, component replacement may be necessary.

The water tank is equipped with an overboard vent (Figure J-1). Maintain a close visual watch on the overboard vent while filling the water tank. Always fill the tank slowly. When the tank is almost full, water will spurt out of the vent.

NOTICE

When filling the tank, never seal the hose to the deck plate. The tank will become pressurized and could rupture.

DO NOT overfill the water tank. Tank damage may result. Water capacity and tank location may vary due to other equipment that may be installed on the boat.

For the potable water capacity, please refer to our Four Winns website at www.fourwinns.com. Tank monitoring systems are standard on the 318 Vista® model. These indicator gauges are typically located in the head for monitoring the water/waste levels. Refer to Figure J-2 and the locator drawing in the back of

this manual for the fresh water tank location. Access to the tank is gained through the forward berth's under berth storage drawer.

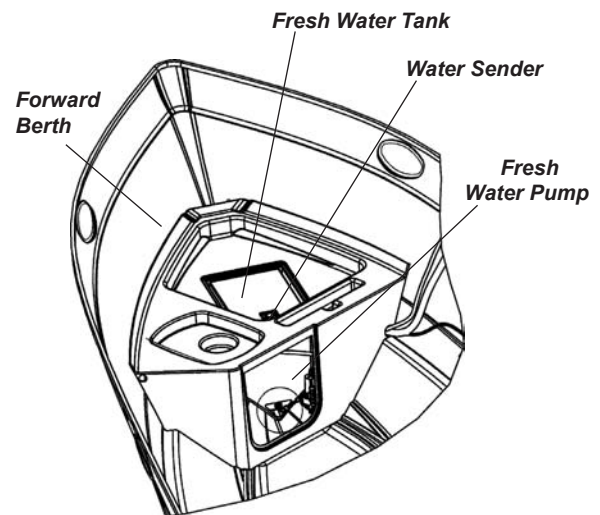

Figure J2: Fresh (Potable) Water Tank Location

The materials from which the components of the water system are made may give the water supply a peculiar taste, especially when new. This condition is normal and can be reduced somewhat through the use of a water filter; such as that produced by PuriTec™. The taste will completely dissipate in time.

WARNING

The fresh (potable) water system should be disinfected prior to initial use.

The water system should be disinfected before first use and at the beginning of each season. The following information is a general guide to disinfecting the fresh water system.

1. Flush the boat's water system thoroughly with fresh water. Make sure all nontoxic antifreeze is removed from the system.
2. The water system should be drained completely.
3. To disinfect the water system, use one gallon of water and 1/4 cup of Clorox™ or Purex™ household bleach (5% sodium hypochlorite solution). This is recommended for each 15 gallons of tank capacity.
4. Allow to stand for three (3) hours. If time is a factor, greater concentrations of chlorine solution will be needed to disinfect the water system.

5. Drain the system.
6. Flush the system thoroughly with fresh water.
7. Fill the system with fresh water.

To remove excessive chlorine taste or odor which might remain in the system, prepare a solution of one quart vinegar to five gallons water and allow this solution to agitate in the tank for several days during boating. Then drain tank and refill with fresh water.

All drains are equipped with traps, and the water will drain slowly. If the system is not operating properly, have it checked by your authorized Four Winns dealer.

J - 2 PRESSURIZED WATER SYSTEM

The water pump is an automatic, on-off, self-priming pump that can service several outlets at once. The pump will build up water pressure and will turn off when it reaches 60 psi. Refer to Figure J-2 and the drawings at the end of this section.

A. Priming the System

After filling the water tank, open all faucets partially. Activate the FRESH WATER circuit breaker switch on the cabin AC/DC panel to supply the system with water. Let the pump run until water comes out of the galley faucet, head faucet and transom shower.

After all the air has been purged from the system and a steady flow of water is coming from each outlet, turn off the faucets one by one. Begin with the cold water faucets and continue until all faucets are shut off. As the pressure builds, the pump will automatically shut off at 60 psi. Refer to Section H-5 - 12 Volt Electrical Equipment and the manufacturer's literature included in the owner's packet for additional information.

B. System Operation

When properly primed and activated, the pressurized water system can be used in the same manner as the water system in a home. An automatic pressure sensor in the water pump keeps the system pressurized. Simply turn on the faucet and water will be delivered. If the system has been recently filled, or has not been used for an extended period of time, air bubbles may accumulate at the pump and/or in the waterlines. If this should happen, re-priming may

be necessary. Refer to the preceding subsection regarding priming the system.

To obtain the most consistent mixture of hot and cold water, turn the cold water on full, then mix in hot water until the desired temperature is obtained. If water pump cycling occurs, some minor variations in water temperature can be expected.

Whenever the boat will be left unattended for an extended period, the water pump circuit breaker switch should be turned to the OFF position. This switch should also be turned OFF whenever the water tank is to remain empty for an extended period of time.

C. Water Heating Systems

A water heater is a standard feature available on the 318 Vista® models. The capacity of the water heater may be found on our website at www.fourwinns.com. Refer to Figure J-3 and to the drawings at the end of this section.

NOTICE

Water heater location may vary due to the installation of optional equipment.

The water heater utilizes 120 volt (220 volt on 50 Hertz models) power. The water heater breaker switch is located on the cabin 120 Volt AC panel.

NOTICE

DO NOT supply 120 volt power to an empty water heater. Damage to the heater will result immediately. The water system must be filled and primed before attempting to use the water heater.

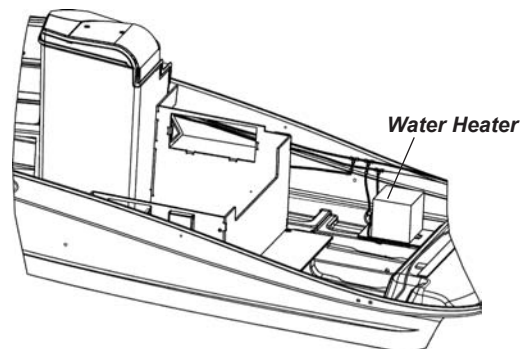

Figure J-3: Water Heater Location

On the 318 Vista® models the water heater incorporates a heat exchanger. The heat exchanger allows the engine coolant to heat a portion of the fresh water supply while the engines are operating. This option will provide hot water at times when 120 volt power is not available. Additional information on heat exchangers is covered in the engine and hot water heater manufacturers' manuals. Please refer to Section H on Electrical Systems for additional information.

D. Using The Shower

Turn on the faucets to desired temperature, remove the shower spout from its holder, move the diverter lever on the shower head, and the shower is operational.

When using the shower, draw the shower curtain before using the shower. Damage to the finish can result if surrounding walls and flooring are allowed to become excessively wet. Thoroughly dry these areas after showering.



The water temperature can vary during shower use as the pressure pump cycles on and off. For greatest consistency, turn the cold water on full, then mix in hot water until the desired temperature is obtained.

A shower sump pump is incorporated into the drain system of the shower. The shower drains into the sump pump located forward of the aft cabin. The water will then be pumped overboard. If a grey water system is installed, the water will be pumped into the grey water holding tank.

The sump pump includes an automatic bilge switch and is protected by a circuit breaker at the AC/DC cabin panel. The sump pump will automatically start as soon as the water in the sump reaches a level that will cause the float on the switch to rise.

After showering, let the water flow for a period of time to flush the pump of soap residue. Check the sump for excess residue. When rinsed out, the pump will automatically shut off.

If water flow from the shower head appears to be restricted, it may be due to sediment accumulating at the shower head. If necessary, remove the head and clean the discharge holes with a fine wire.

Periodically check the sump pump screen for clogs to prevent drainage problems from occurring in the shower drain. Refer to the manufacturer's literature included in the owner's packet.

J - 3 GREY WATER SYSTEM

The grey water system is optional on Vista® models. The water from the galley sink, head sink and shower will drain into a sump and is pumped into a grey water holding tank respectively. The waste level indicator is located in the head compartment. A pumpout fitting labeled WASTE but designated for grey water is provided on the deck. Refer to the drawings at the end of this section.

NOTICE

Certain geographical areas have restrictions on grey water being pumped or drained overboard. Be sure to check all local, state and federal laws in the boating area.

J - 4 SHORE WATER CONNECTION

Shore water connection is standard on the 318 Vista® models. This feature allows the direct connection of a city or shoreside water supply to the boat's water system to provide a constant supply of fresh water without the need to constantly refill the water supply tank. This minimizes pressure pump operation thus extending the life span of the pump.

Dockside shore water pressure can vary dramatically. Excess pressure could damage the boat's water system so the shore connection also regulates the water pressure to a maximum of 35 psi.

The shore water inlet/regulator fitting is located outboard, on the starboard side of the transom above the swim platform, inside the transom washdown storage area. See Figures J-3 and the drawings at the end of this section.

To use shore water, connect a hose from the shore water faucet to the shore water fitting on the boat and turn on the shore water. The water system of the boat will then be pressurized by city water if the system was previously primed.

The water pump should be turned off when using city water. If the pump is OFF, the pump will not function and the water in the storage tank of the boat will not be utilized.

NOTICE

Always remember to disconnect the shore water supply hose before leaving the dock.

Always turn off the shore water whenever the boat is left unattended. If a major water leak did occur and went undetected, the boat could fill with water and sink.

DO NOT alter or repair the pressurized water system or shore water connection without having proper knowledge of the system. Damage to the water system can occur.

See Section J-1 for general water system information and instructions on filling the water tank. The water tank will not be filled while connected to shore water.

J - 5 TRANSOM SHOWER

A transom shower with a choice of hot/cold water is standard on the 318 Vista® models. The shower unit is located on the starboard side of the transom systems locker. Refer to Figures J-4 and to the drawings at the end of this section.

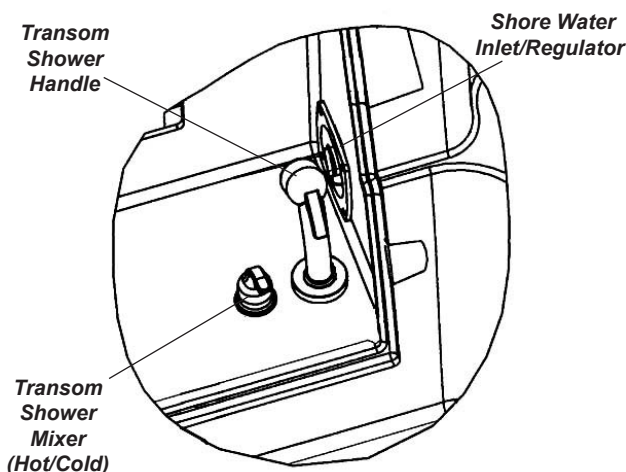

Figure J-4: Transom Shower

The water supply system can be used for showering or washing down the transom area. As long as there is water pressure, the shower faucet will operate. Fresh water tank capacity is limited. Connect the boat

to shore water before using large amounts of water as required when washing down the transom/swim platform area.

J - 6 HEADS

The various anti-pollution laws presently in effect have necessitated the use and availability of a wide variety of heads. The heads that have been factory installed in Four Winns® boats have been chosen to provide reasonable longevity and reliable service, at a realistic cost. Refer to the drawings at the end of this section. Also, refer to the manufacturers literature included in the owner's packet.

A. VacuFlush® Sanitation System

The VacuFlush® sanitation system is standard on the 318 Vista®. The system eliminates the unpleasant sulfide odors which plague saltwater systems. Flush water is no longer drawn through the through-hull fittings, seacock, and vented loop. It also extends the life of the system components by eliminating salt water and impurities from accumulating in the system over time.

The VacuFlush® toilet operates in a different way from other marine toilets. VacuFlush® systems use a small amount of water (a little more than a pint) per flush in addition to a simple vacuum. The toilet is connected to the fresh water system. Fresh water is the key to an odor free bathroom compartment. VacuFlush® toilets are equipped with an integrated vacuum breaker which prevents the possible contamination of the potable/fresh water supply. See Figures J-5 & J-6. Also refer to the manufacturer's literature included in the owner's packet.

NOTICE

The VacuFlush® (TOILET) switch located in the head must be ON in order for the toilet to flush & recharge.

To operate:

1. To add water to the toilet before using, raise flush lever until desired water level is reached. Generally, more water is required only when flushing solids. See Figure J-5.
2. To flush toilet, press flush lever sharply down to the floor until contents clear bowl. A sharp popping

noise is normal when the vacuum seal is broken and the flushing action begins. **Be sure to hold lever down for 3 seconds.** If flush lever is accidentally released before waste clears bowl, do not attempt to flush toilet again until vacuum pump stops running. A small amount of water should remain in the bowl after flushing.

- Do not dispose of sanitary napkins or other non-dissolving items in toilet, such as facial tissue or paper towels. These items can cause plugging of the system. Refer to the “Deodorants and Special Tissue” section in the manufacturer’s manual for more information.

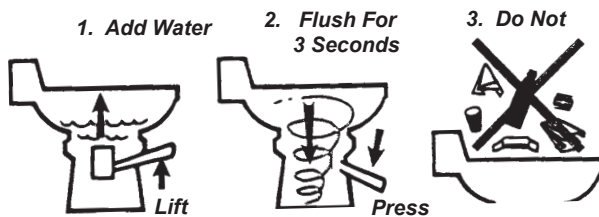

Figure J-5: VacuFlush Operations

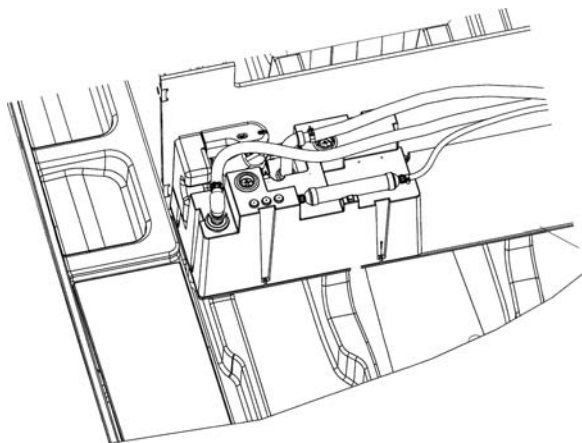

Figure J-6: VacuFlush® Waste Holding Tank System

B. Head With Overboard Discharge

This option is available on the 318 Vista® models. The head toilet operations are the same as the systems described earlier. A discharge pump is incorporated into the VacuFlush® waste holding tank system. An additional hose with a seacock has also been installed for overboard discharge. Refer to Figure J-7.

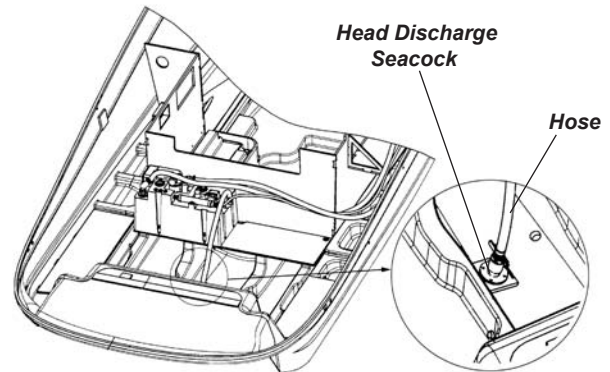

Figure J-7: Overboard Discharge Option

NOTICE

The discharge pump must be used to discharge waste overboard. However, DO NOT use the discharge pump to discharge waste at a pumping station.

To operate the overboard discharge system:

- The discharge valve is located in the engine compartment labeled HEAD DISCHARGE. To open, turn the valve so that the handle is parallel to the flow of the valve. The waste deck plate cover must be tightened securely for the overboard discharge system to operate.
- Turn ON the overboard discharge switch which is located in the head on the switch panel. Allow the discharge pump to run until the storage tank is empty. The sound of the pump’s motor load and speed will change when the tank becomes empty.
- Turn the overboard discharge switch off.
- Turn the head discharge valve handle to the closed position, and secure it. This thru-hull valve (seacock) must be closed to prevent water from being forced back into the system.

NOTICE

Discharging waste overboard is illegal in most US waters today. Discharge is limited to certain coastal waters, a designated distance offshore. Check with your local boating regulations before proceeding with any discharge activities.

Some local regulations require overboard discharge systems be physically secured in a closed position during use of the boat in waters designated as “no discharge” areas. Check with local boating regulations. Refer to the manufacturer’s literature for additional information.

C. Dockside Waste Pump Out

On most Vista® models waste pump out capability is available. Waste can be removed from the holding tank by taking the boat to a dockside waste pumping station. Most marina fueling facilities provide such services.

The waste holding tank should be emptied upon visual inspection of the waste holding tank and determining the waste holding tank’s capacity is almost full or by using the waste level indicator if so equipped. Waste level indicators are typically located in the head. **DO NOT ALLOW THE WASTE TANK TO BECOME OVERFILLED.**

To pump out the holding tank:

1. Be sure the head has some water in the bowl.
2. Connect the dockside pump out connection to the WASTE plate located on the deck.

NOTICE

Usually the dockside pump out connection will screw into the waste deck plate or has a rubber sleeve that inserts into the plate and must be held in position during the pump out operation. If the hose is not air tight or connected properly, waste could spurt out or leak around the deck fitting and into the boat.

3. Have the pumping station operator activate the pumping equipment. The waste will be drawn from the holding tank and into the pumping station’s disposal tank.

4. Remove the pump out connection from the deck plate. Add at least 5 gallons of clean water to the holding tank on most models through the waste deck fitting using a dockside water hose.
5. Repeat steps 2 & 3 above to pump out the water used in step 4 to flush the holding tank.
6. Add waste holding tank treatment chemical to the head bowl. It is available from the dockside pumping station or can be obtained from your dealer. Flush at least twice.

CAUTION

Be careful when handling and storing treatment chemicals. Not only are they toxic, but they will also stain and damage surrounding surface.

J - 7 SYSTEM MAINTENANCE

Information supplied with water and waste system components by the equipment manufacturers is included with this manual. Refer to this literature for additional operation and service information.

Be sure the batteries in the boat are properly charged. Operating the pressure pump from a battery with a low charge will result in pump cycling. This could lead to premature pump failure.

CAUTION

The decomposition of waste produces a colorless, odorless gas, methane, that is lighter than air, combustible, and extremely lethal. Always provide sufficient ventilation when effecting repairs to the waste system and allow no odor from the waste system to go unresolved.

A. Clean Vents and Screens

Periodically, inspect the water tank vents and thru-hull vent fittings for any dirt, wax, etc. Carefully remove any obstruction with a pipe cleaner or similar device. **Be sure not to puncture the screen.** The stainless steel vent cap is not removable.

NOTICE

Failure to keep the water tank vent fittings clean will cause excessive pressure buildup within the tank during filling. This can cause water tank damage.

Periodically remove the filter screens from the faucet discharge spouts and shower head. Remove the accumulation of sediment from the screens. If necessary, clean out the holes using a fine wire. A buildup of debris in the faucet filter screens can create enough restriction to cause the pump to cycle on and off.

Check the in-line water filter/screen for sediment and blockage. It is located between the water tank and the pressure water pump. If obstructed, remove from the water line and either clean or replace the part. The filter unit will twist apart.

Inspect and clean the shower sump every 30 days. Some water will always be in the compartment. Sediment and other debris will buildup and affect the automatic bilge switch and pump operation. Remove the pump's cover and clean the screen. The screen will become blocked and the pump will not operate properly. To clean the compartment, use baking soda and a fine wire brush to remove dirt and other debris. This will also serve to disinfect the area.

B. Winterizing the Water System

Winter lay-up service procedures should include a thorough draining of the water system. Disconnect all accessible fittings. Blow out all lines. Be sure the hot water heater, fresh and grey water tanks, transom shower, pumps and lines are completely dry. Leave all faucets open. Freezing water can cause severe damage to all water system components.

NOTICE

Always winterize the fresh water system prior to winterization of the hull drainage (bilge pump) system.

Draining the system as mentioned can be very tedious and an incomplete job can result in expensive repairs. The use of nontoxic antifreeze (such as R.V. antifreeze) designed for fresh water systems considerably reduces the work necessary and is a more positive means of winterizing the system. Follow the directions included with the antifreeze solution.

To winterize:

1. Turn on the water pump and drain the water tank by opening a faucet (the pump will run faster when it is empty).

NOTICE

Be sure the circuit breaker for the water heater in 120 Volt AC panel is in the OFF position. The water heater will be damaged immediately by supplying electrical power to an empty water heater.

DO NOT run the water pump without water in the system. Pump damage will result. Be watchful and turn the pump off as soon as the tank becomes empty.

2. Add 15 gallons of R.V. antifreeze to the water tank.

NOTICE

Generally the hot water heater will require approximately five gallons of antifreeze before the hot water lines will have antifreeze running through them. The cold water faucet should be turned OFF at some point to test for antifreeze in the hot water line.

3. Turn ON all faucets (both hot and cold) until undiluted antifreeze is seen. Make sure the transom shower, head faucet and galley faucet have antifreeze coming out.
4. Activate the shower sump pump and pour approximately 1 quart of nontoxic antifreeze down the shower drain. The shower sump will discharge some of the antifreeze overboard.



Use only nontoxic antifreeze solutions such as R.V. antifreeze. DO NOT use ethylene glycol solutions; the type that is used in engine coolant systems. These are toxic.

NOTICE

Be sure to wipe up any antifreeze that has been spilled on the fiberglass shower surfaces.

C. Winterizing the Waste System

To winterize the waste holding tank, flush the tank with soap, water and a deodorizer (e.g., Lysol Liquid™). Empty the tank and pour two (2) gallons (3 gallons if equipped with overboard discharge) of R.V. antifreeze into the bowl and flush.

If the boat is equipped with overboard discharge capabilities, follow the normal procedures above. Run the discharge pump only long enough until the antifreeze solution is being pumped overboard.

For additional information, refer to the manufacturer's manuals in the owner's packet.

NOTICE

The instructions listed in this section provide a working knowledge to winterize the water and waste systems. However, to prevent possible damage to components in your boat, Four Winns recommends having the boat winterized by your Four Winns dealer.

FIGURE J-8: 318V FRESH WATER SYSTEM (1 OF 6)

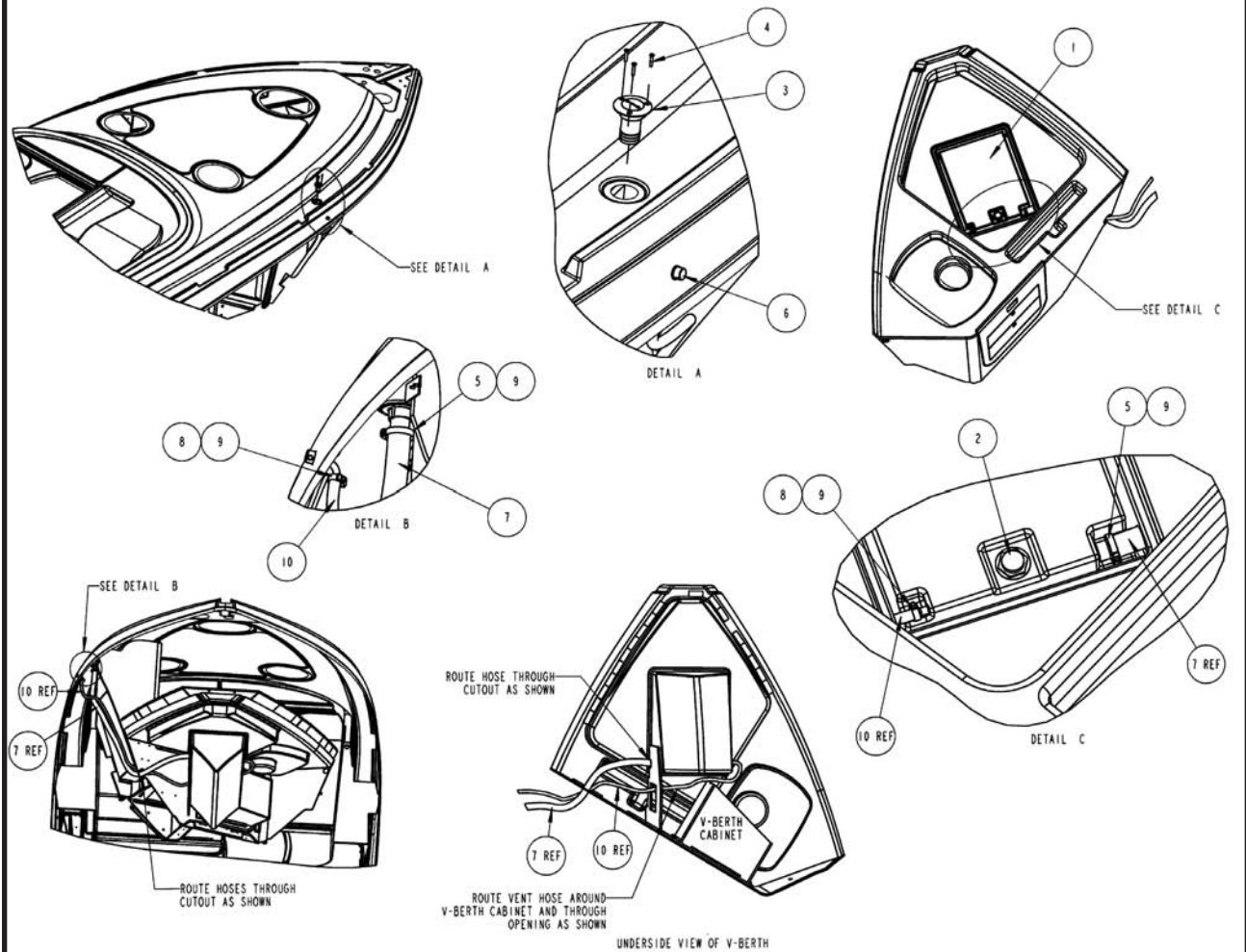

#	DESCRIPTION	PART No.	QTY	U/M
1	TANK, WATER, 35 GAL., 308V "05"	035-1382	1	EA
2	SENDER, WATER 19" TS-19	026-0607	1	EA
3	FILL, WATER 1-1/2" MARINE HDWR	031-0087	1	EA
4	SCREW, #10 x 1" POHMS	080-0035	3	EA
5	CLAMP, 1 1/2" #24 FILL HOSE	021-0032	2	EA
6	VENT, 90 DEG. ELBOW GEM	035-1332	1	EA
7	HOSE, 1-1/2" ODORSAFE	022-0055	8	FT
8	CLAMP, 5/8 INCH #10H FUEL VENT	021-0031	2	EA
9	BOOT, HOSE CLAMP	030-0864	4	EA
10	HOSE, 5/8" WASTE	022-0013	8	FT

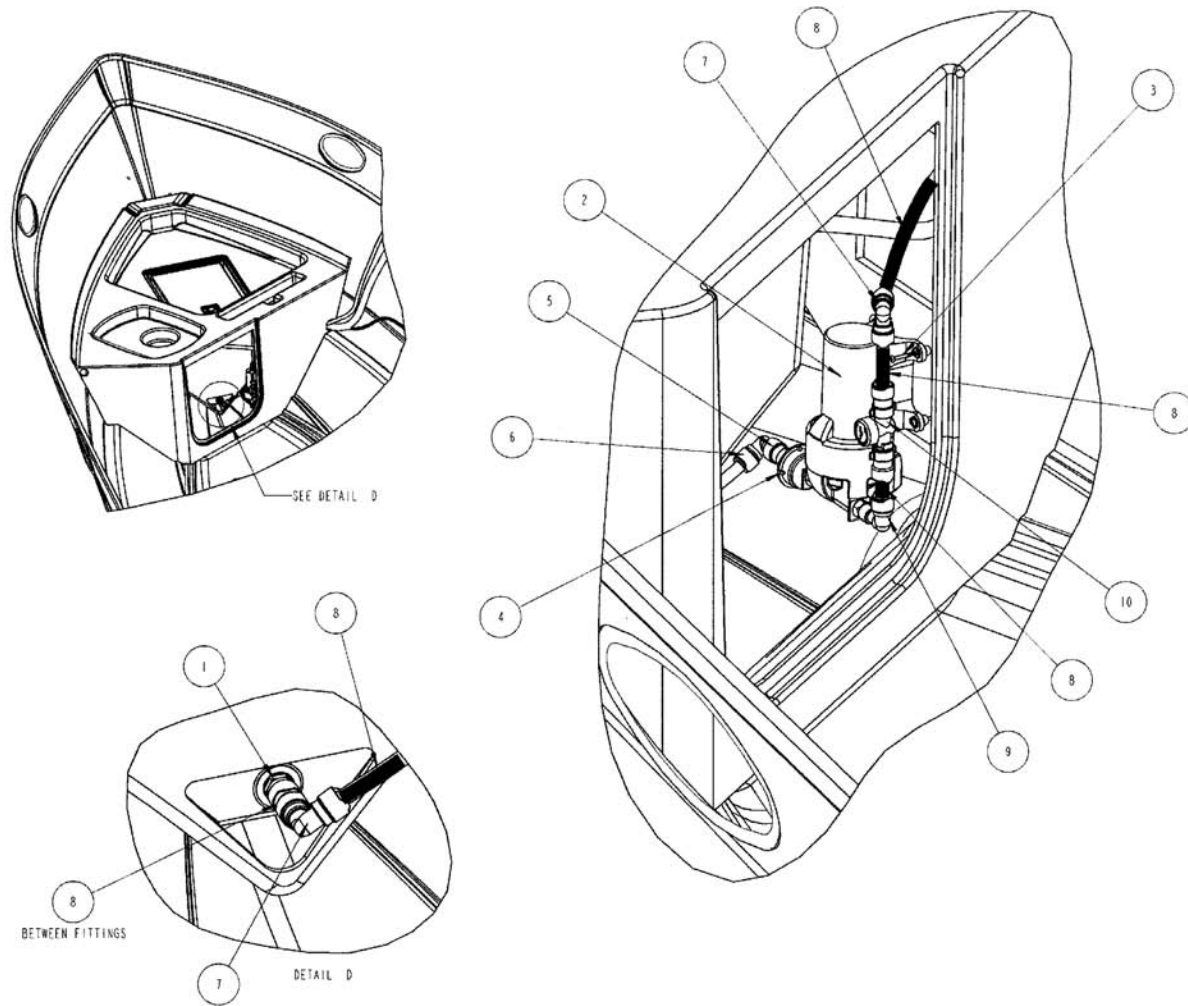
FIGURE J-9: 318V FRESH WATER SYSTEM (2 OF 6)

#	DESCRIPTION	PART No.	QTY	U/M
1	ADAPTER, MALE 1/2" x 15mm	035-0934	1	EA
2	PUMP, FRESH WATER SHURFLOW	026-0662-02	1	EA
3	SCREW, #8 x 1-1/4" PTHSMS	080-0807	4	EA
4	FILTER, IN-LINE SHUREFLO	035-0158	1	EA
5	WS1504B CONNECTOR STRAIGHT	035-0933	1	EA
6	ELBOW, SEM WX1522B	035-1002	1	EA
7	ELBOW, 15mm WX1503B	035-0929	2	EA
8	TUBING, BLUE 15MM X 50M	035-0936	68	FT
9	ELBOW, ADAPTER 1/2" BSP #WX1531B	035-1003	1	EA
10	VALVE, SHUT-OFF 15 MM	035-0932	1	EA

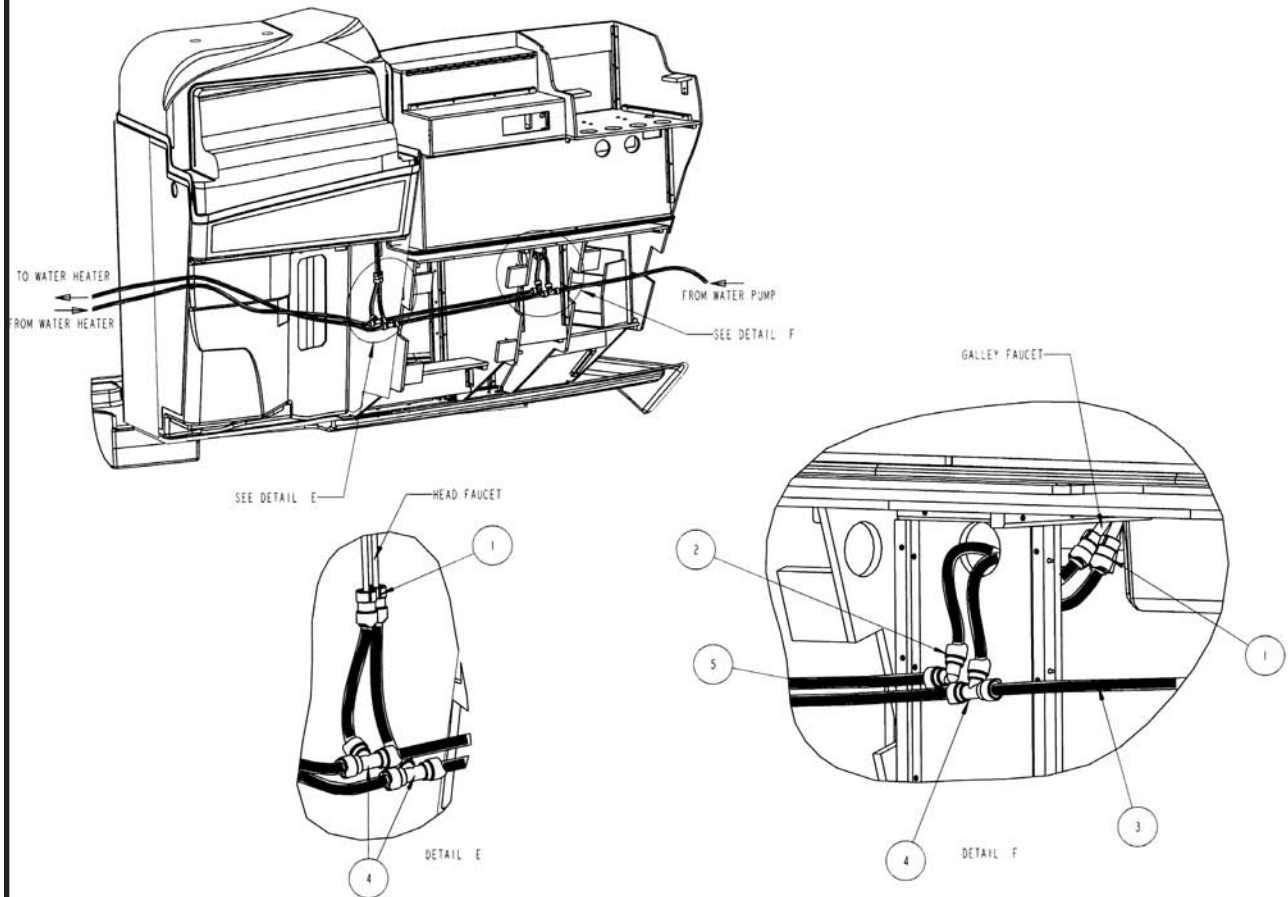
FIGURE J-10: 318V FRESH WATER SYSTEM (3 OF 6)

#	DESCRIPTION	PART No.	QTY	U/M
1	WS1504B CONNECTOR STRAIGHT	035-0933	4	EA
2	ELBOW, 15mm WX1503B	035-0929	1	EA
3	TUBING, BLUE 15MM X 50M	035-0936	REF	
4	TEE, 15mm WX1502B	035-0928	3	EA
5	TUBING, RED 15MM X 50M	035-0937	31	FT

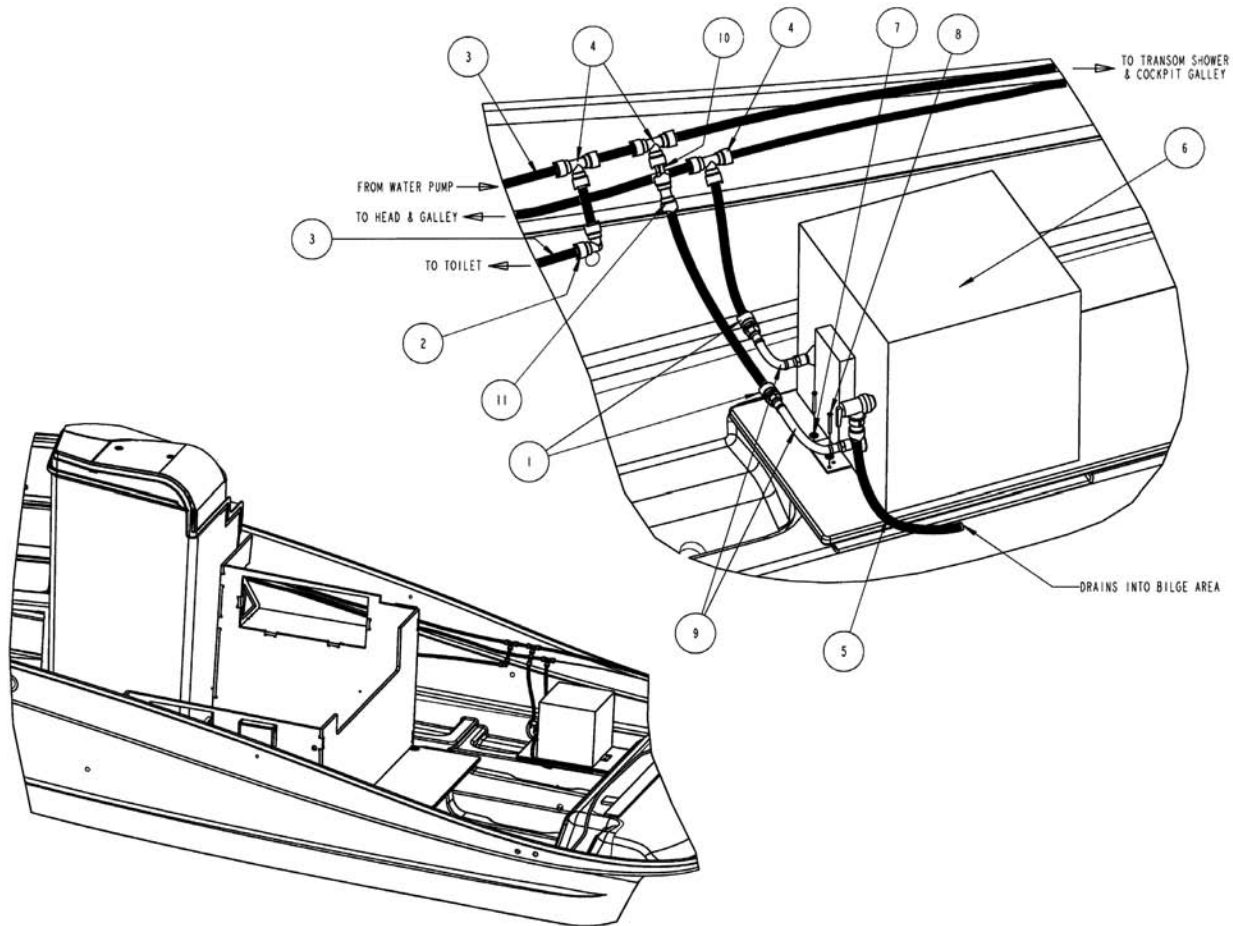
FIGURE J-11: 318V FRESH WATER SYSTEM (4 OF 6)

#	DESCRIPTION	PART No.	QTY	U/M
1	ADAPTER, MALE 1/2" x 15mm	035-0934	2	EA
2	ELBOW, 15mm WX1503B	035-0929	1	EA
3	TUBING, BLUE 15MM X 50M	035-0936	REF	
4	TEE, 15mm WX1502B	035-0928	3	EA
5	TUBING, RED 15MM X 50M	035-0937	REF	
6	WATER HEATER, ELECTRIC W/ HEAT	065-0829	1	EA
7	WASHER, FINISH #8 SS FLANGE WFFSS8	080-0091	4	EA
8	SCREW, #10 x 1-3/4" POHSMS	080-0036	4	EA
9	CONNECTOR, WATER HEATER 1/2"	035-1260	2	EA
10	CHECK VALVE, 15 MM	035-0985	1	EA
11	WS1504B CONNECTOR STRAIGHT	035-0959	1	EA

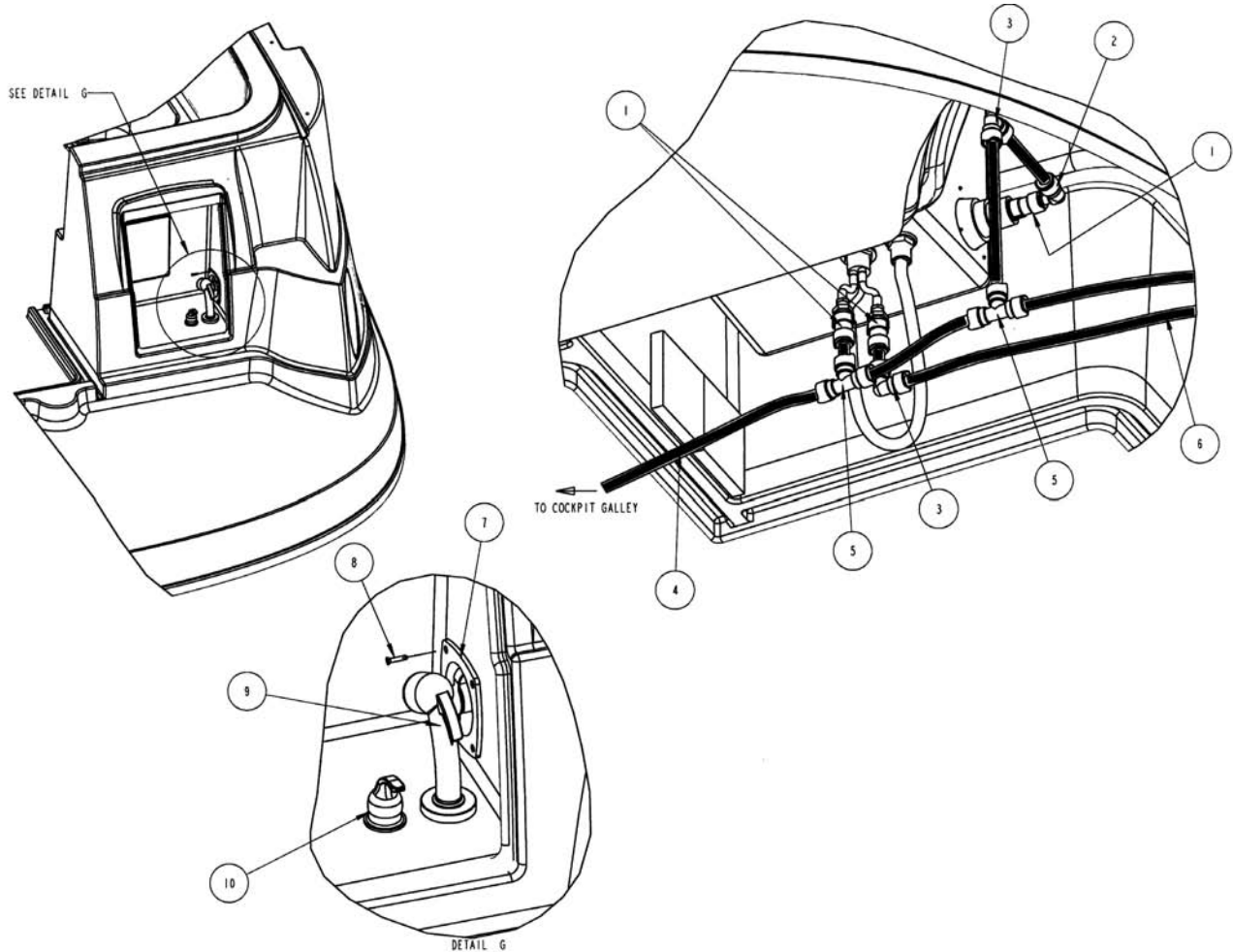
FIGURE J-12: 318V FRESH WATER SYSTEM (5 OF 6)

#	DESCRIPTION	PART No.	QTY	U/M
1	WS1504B CONNECTOR STRAIGHT	035-0933	3	EA
2	ELBOW, SEM WX1522B	035-1002	1	EA
3	ELBOW, 15mm WX1503B	035-0929	2	EA
4	TUBING, BLUE 15MM X 50M	035-0936	REF	
5	TEE, 15mm WX1502B	035-0928	2	EA
6	TUBING, RED 15MM X 50M	035-0937	REF	
7	FITTING, WATER INLET/REG	035-0027	1	EA
8	SCREW, #8 x 3/4" POHSMS	080-0022	4	EA
9	HANDLE, TRANSOM SHOWER W/HOLDER	035-1258	1	EA
10	MIXER, TRANSOM SHOWER 318V	035-1257	1	EA

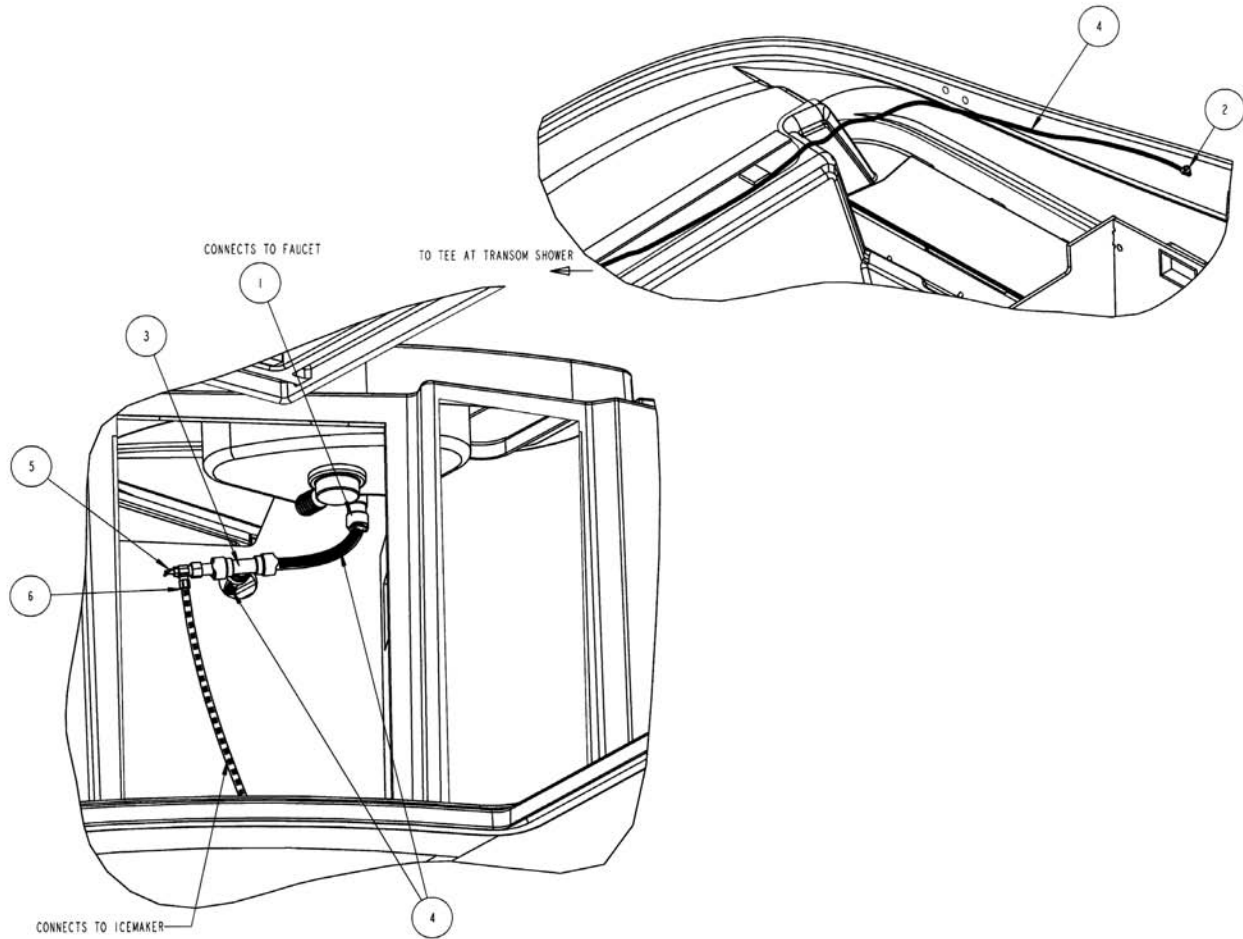
FIGURE J-13: 318V FRESH WATER SYSTEM (6 OF 6)

#	DESCRIPTION	PART No.	QTY	U/M
1	WS1504B CONNECTOR STRAIGHT	035-0933	1	EA
2	ELBOW, 15mm WX1503B	035-0929	1	EA
3	TEE, 15mm WX1502B	035-0928	1	EA
4	TUBING, BLUE 15MM X 50M	035-0936	REF	
5	VALVE, STEM FITTING, 15mm	035-0991	1	EA
6	SLEEVE, PLASTIC 1/4" COMP	035-1368	1	EA
7	TUBING, ICE MAKER DRAIN	022-0150	3	FT

FIGURE J-14: 318V HEAD HARDWARE (1 OF 3)

FIGURE J-15: 318V HEAD HARDWARE (2 OF 3)

#	DESCRIPTION	PART No.	QTY	U/M
1	DRAIN, SINK #101045-00	035-0225	1	EA
2	CLAMP, 1 1/4" HOSE	021-0035	2	EA
3	BOOT, HOSE CLAMP	030-0864	2	EA
4	THRU HULL, 1" S.S.	035-1265	1	EA
5	HOSE, 1" BLACK PVC	022-0047	2	FT

FIGURE J-16: 318V HEAD HARDWARE (3 OF 3)

FIGURE J-17: 318V WASTE WATER SYSTEM (1 OF 4)

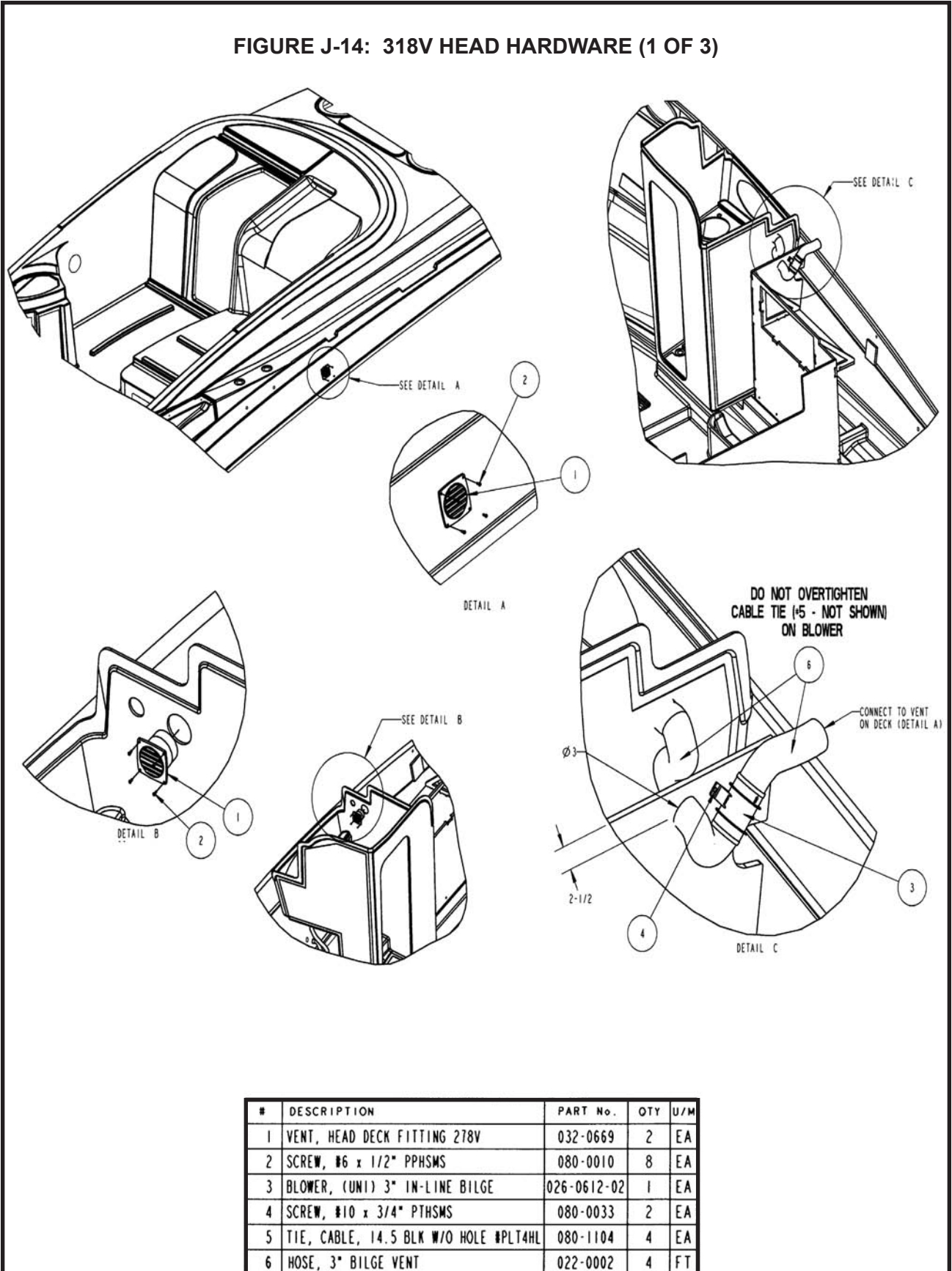
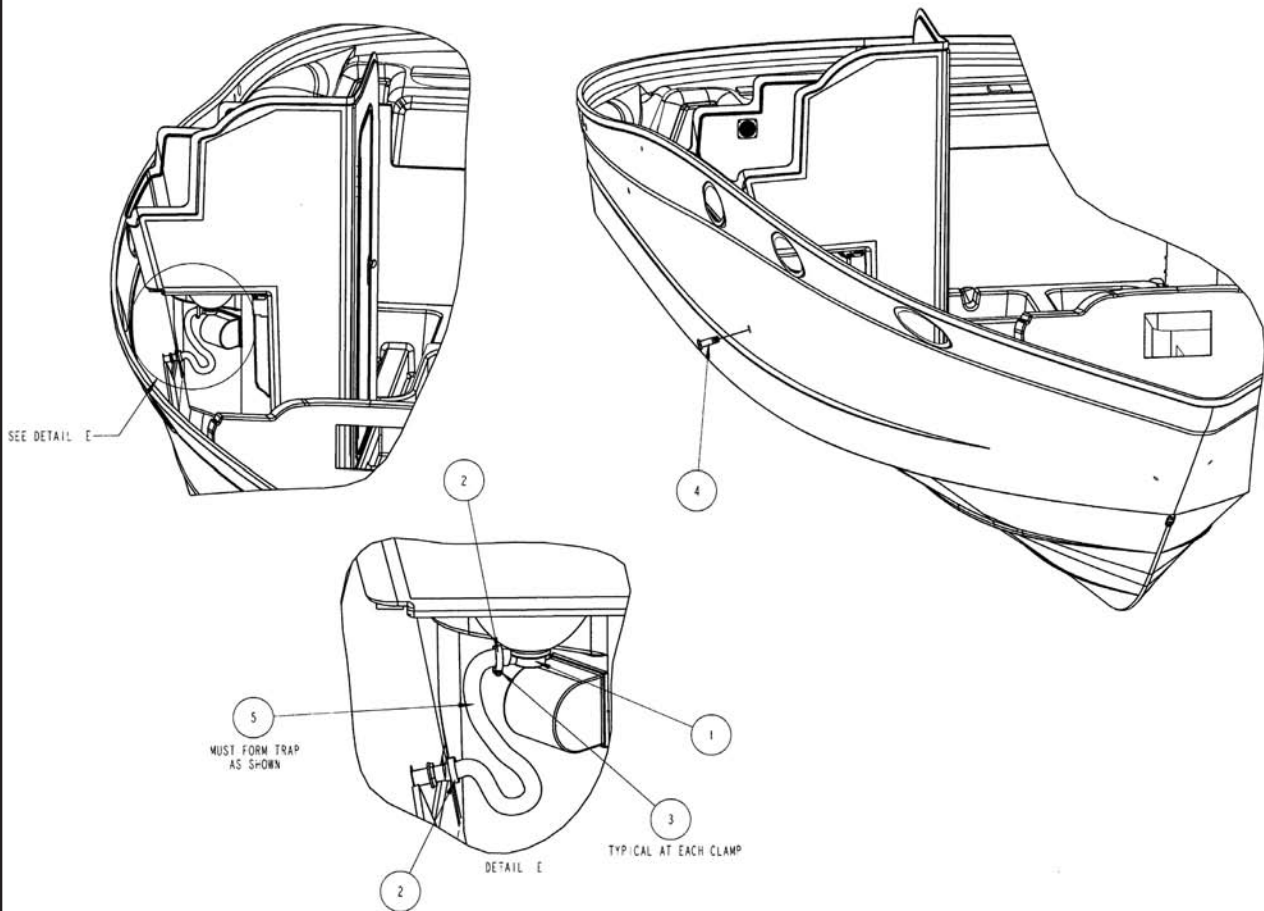
#	DESCRIPTION	PART No.	QTY	U/M
1	VACUFLUSH HLDNG TANK SYS STD WASTE 27.5	035-1395	1	EA
2	CLAMP, T-BOLT 1-7/8" #70STBC18	021-0371	2	EA
3	CLAMP, 5/8 INCH #10H FUEL VENT	021-0031	1	EA
4	BOOT, HOSE CLAMP	030-0864	1	EA
5	SCREW, #10 x 1-1/2" POHMS	080-0032	8	EA
6	HOSE, 1-1/2" ODORSAFE	022-0146	50	FT
7	HOSE, 5/8" WASTE	022-0013	15	FT

FIGURE J-18: 318V WASTE WATER SYSTEM (2 OF 4)

#	DESCRIPTION	PART No.	QTY	U/M
1	SUMP, SHOWER 800gph	026-0629	1	EA
2	SCREW, #10 x 3/4" PTHSMS	080-0033	4	EA
3	CLAMP, 1 1/4" HOSE	021-0035	8	EA
4	BOOT, HOSE CLAMP	030-0864	8	EA
5	TEE, 1" X 1" X 1-1/8" ALL BARBED	035-1393	1	EA
6	HOSE, 1" BLACK PVC	022-0047	18	EA
7	HOSE, 1-1/8" BLACK PVC	022-0048	9.5	EA
8	THRU HULL, 3/4" S.S.	035-1263	1	EA
9	HOSE, 3/4" BLACK PVC	022-0046	REF	
10	DRAIN, SHOWER FLOOR	035-0616	REF	
11	DRAIN, SINK #101045-00	035-0225	REF	

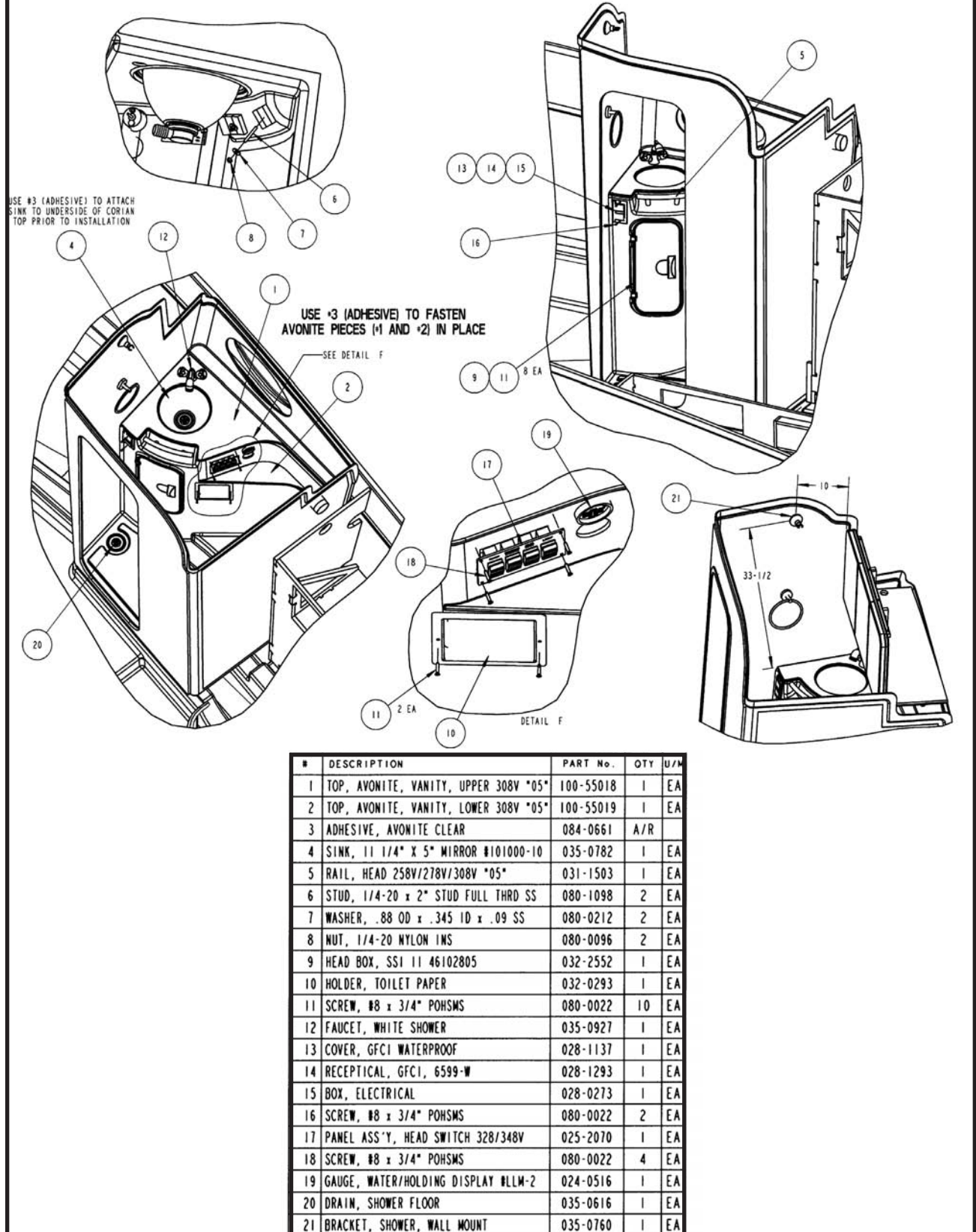
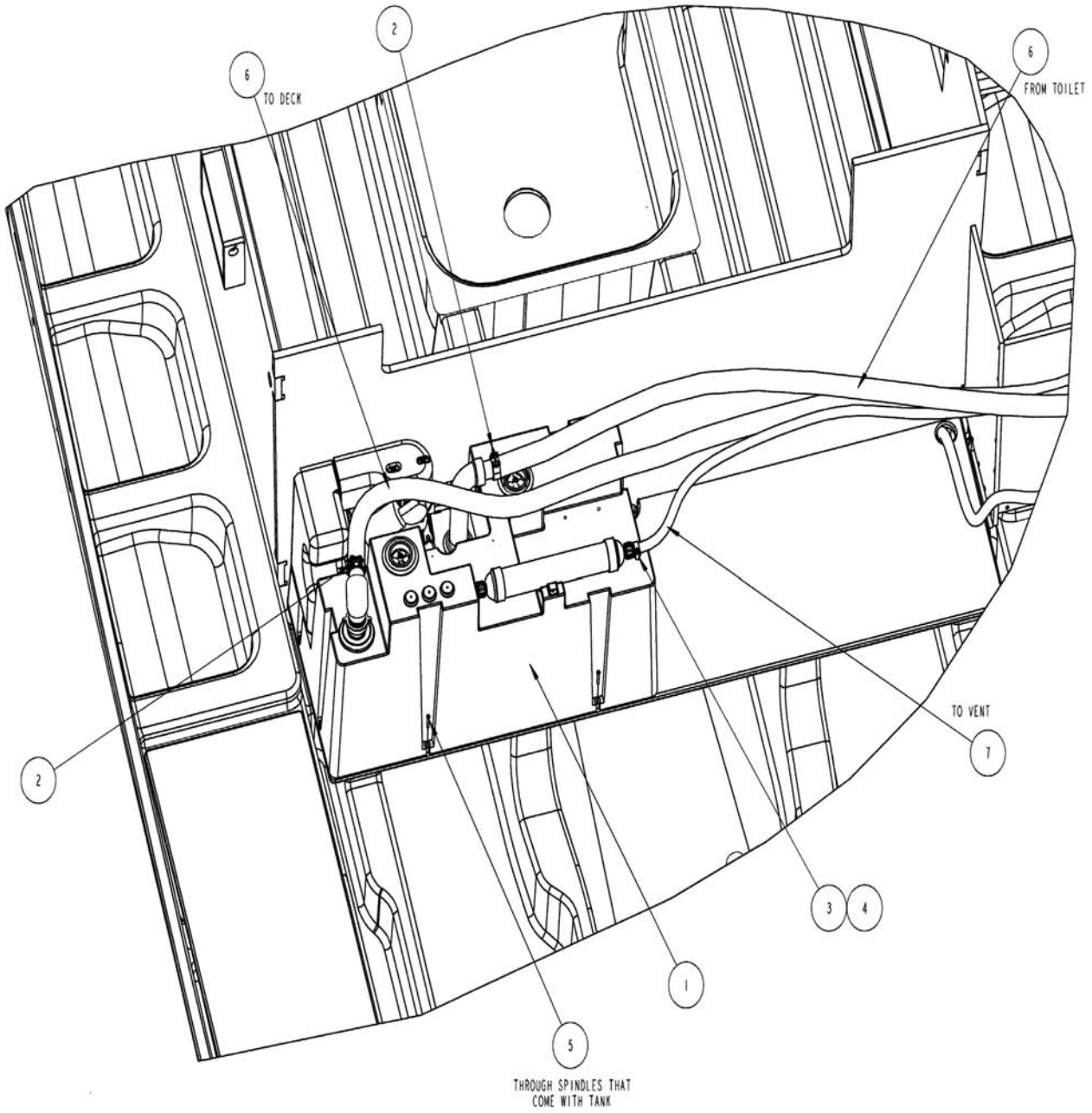
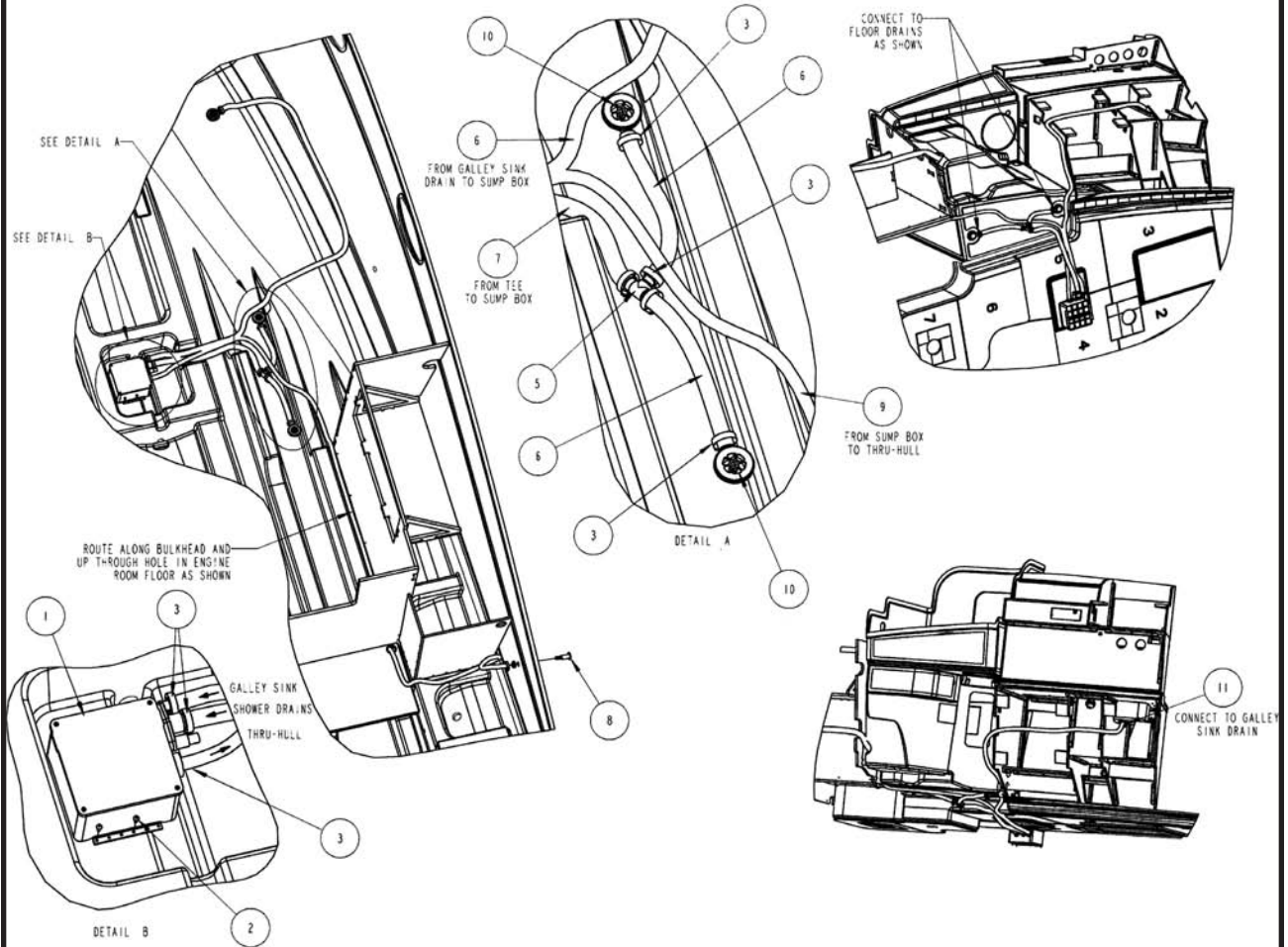
FIGURE J-19: 318V WASTE WATER SYSTEM (3 OF 4)

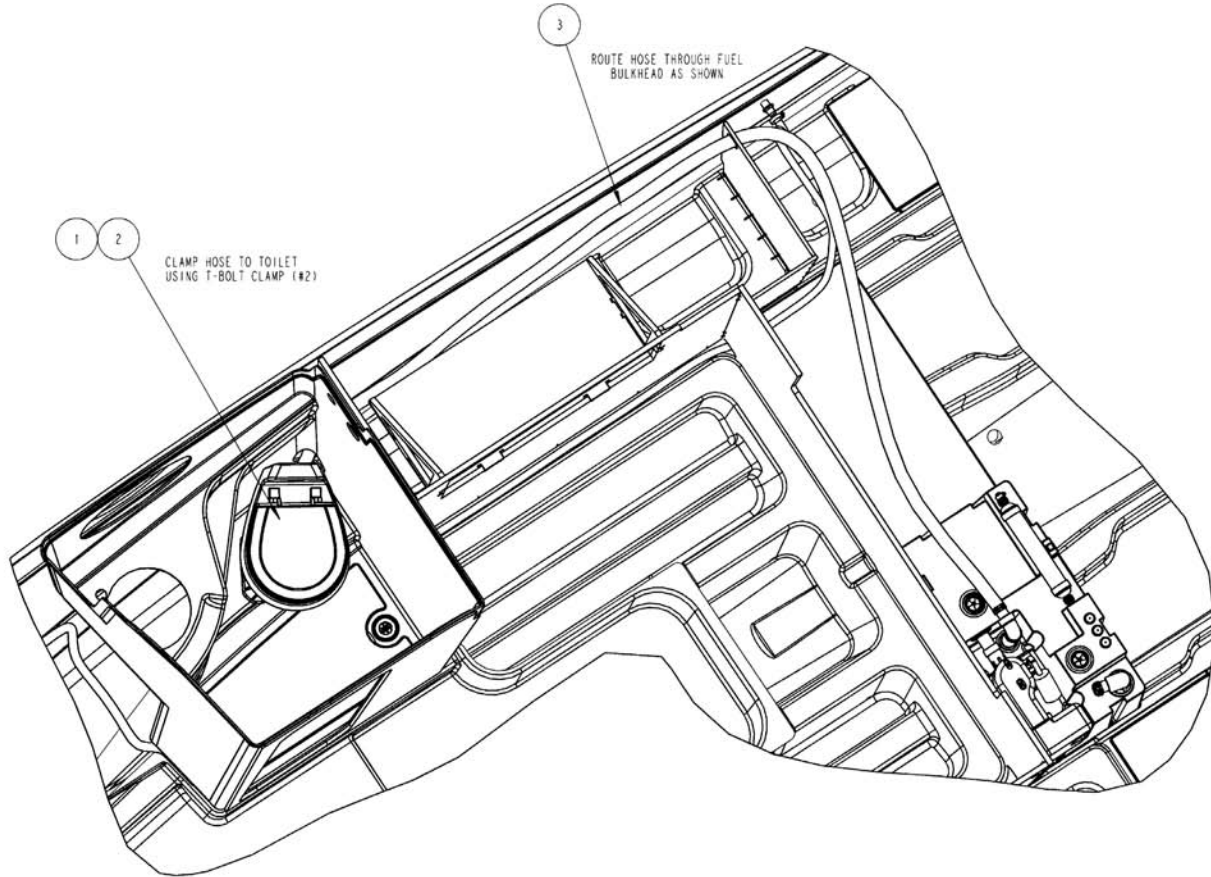

#	DESCRIPTION	PART No.	QTY	U/M
1	TOILET, VACUFLUSH 1148, WHITE	035-1380	1	EA
2	CLAMP, T-BOLT 1-7/8" #70STBC18	021-0371	1	EA
3	HOSE, 1-1/2" ODORSAFE	022-0146	REF	

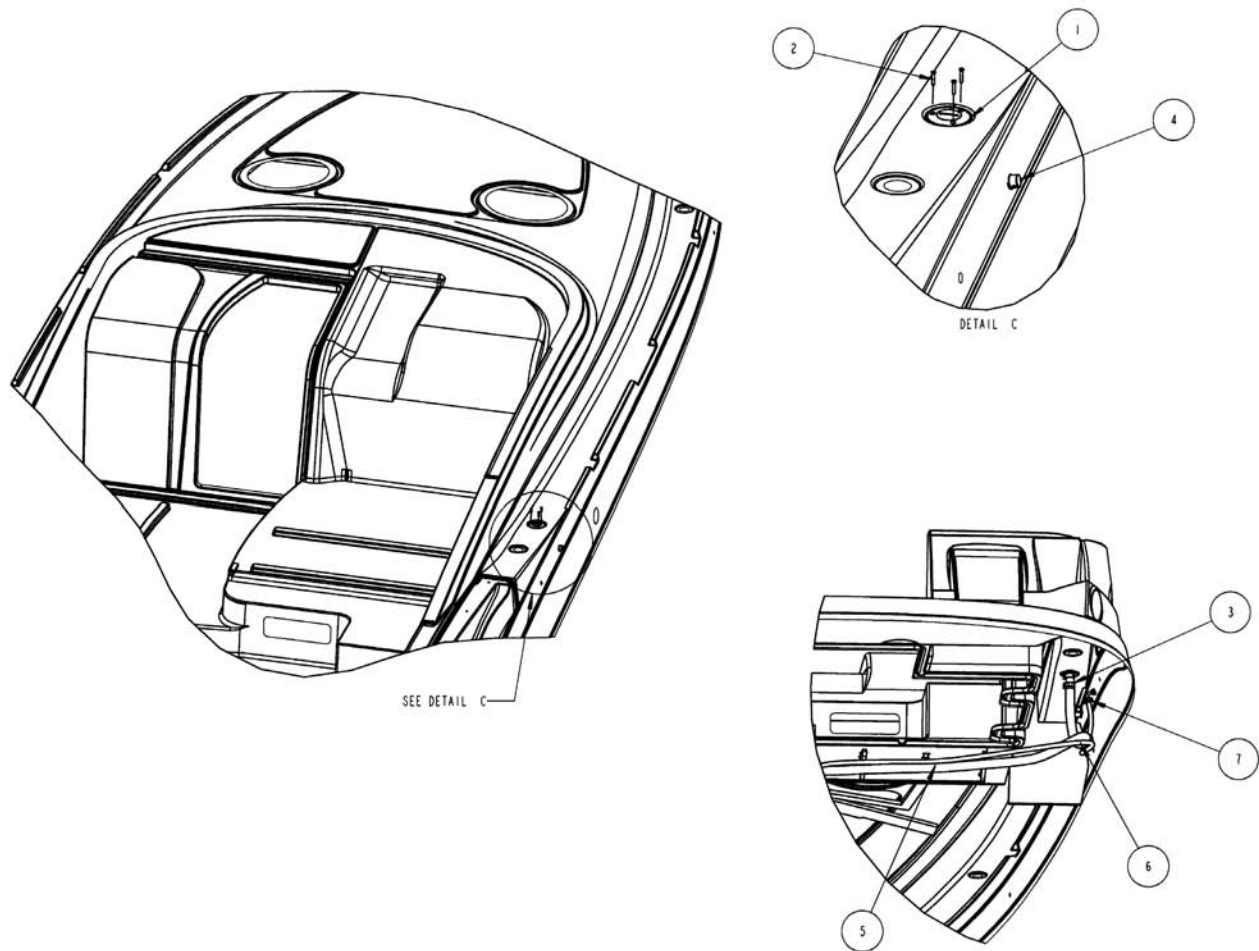
FIGURE J-20: 318V WASTE WATER SYSTEM (4 OF 4)

#	DESCRIPTION	PART No.	QTY	U/M
1	FILL, WASTE 1-1/2" MARINE HDWR	030-1886	1	EA
2	SCREW, #10 x 1" POHSMS	080-0035	3	EA
3	CLAMP, T-BOLT 1-7/8" #70STBC18	021-0371	1	EA
4	VENT, 90 DEG. ELBOW GEM	035-1332	1	EA
5	HOSE, 1-1/2" ODORSAFE	022-0146	REF	
6	HOSE, 5/8" WASTE	022-0013	REF	
7	CLAMP, 1 1/4" HOSE	021-0035	1	EA
8	BOOT, HOSE CLAMP	030-0864	1	EA

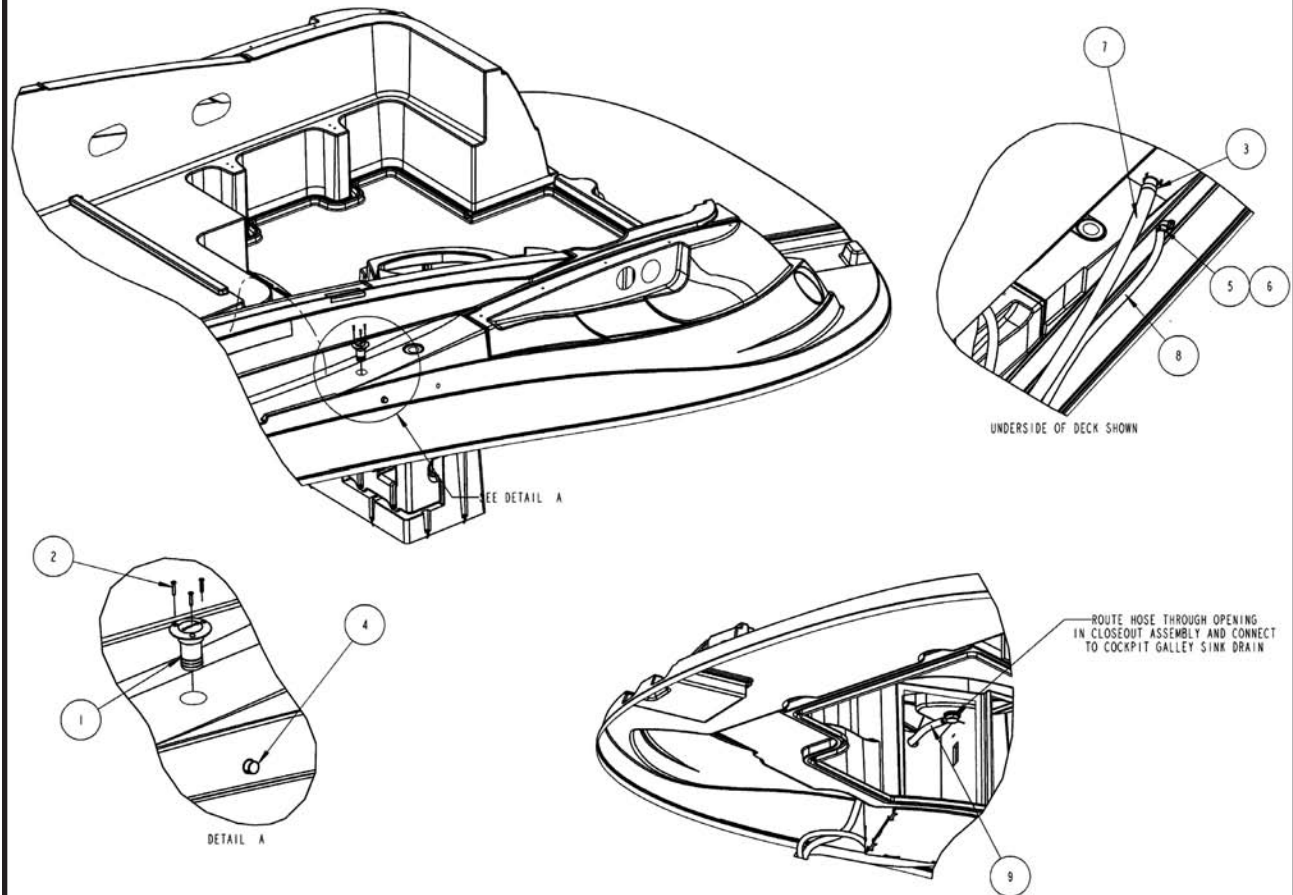
FIGURE J-21: 318V GRAY WATER SYSTEM OPTION (1 OF 4)

#	DESCRIPTION	PART No.	QTY	U/M
1	FILL, WASTE 1-1/2" MARINE HDWR	030-1886	1	EA
2	SCREW, #10 x 1" POHWS	080-0035	3	EA
3	CLAMP, T-BOLT 1-7/8" #70STBC18	021-0371	1	EA
4	VENT, 90 DEG. ELBOW GEM	035-1332	1	EA
5	CLAMP, 5/8 INCH #10H FUEL VENT	021-0031	1	EA
6	BOOT, HOSE CLAMP	030-0864	1	EA
7	HOSE, 1-1/2" ODORSAFE	022-0146	8	FT
8	HOSE, 3/4" BLACK PVC	022-0046	14	FT
9	HOSE, 1" BLACK PVC	022-0047	22	FT
10	KEY, GAS CAP #66060-1	031-0085-2	1	EA

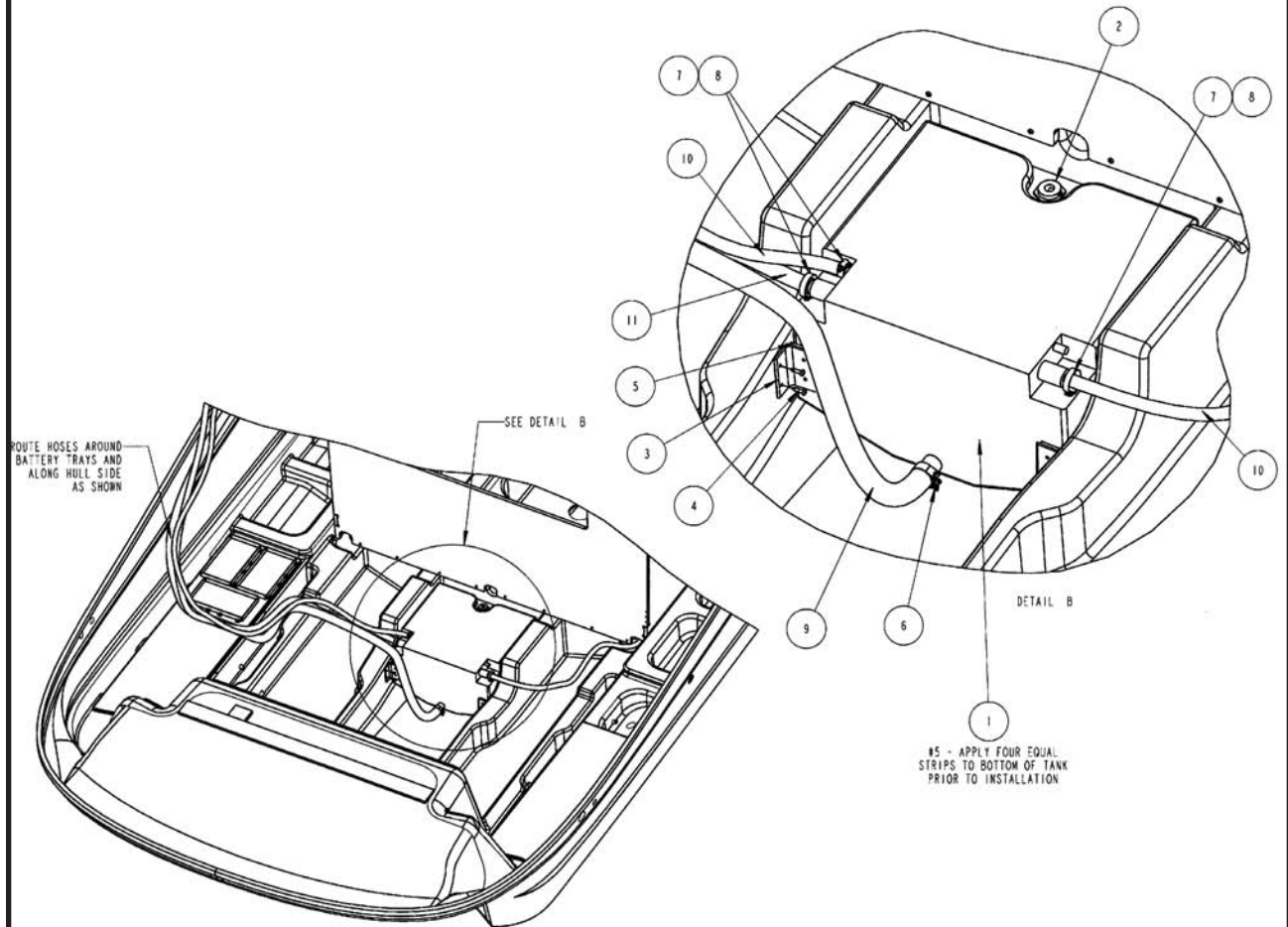
FIGURE J-22: 318V GRAY WATER SYSTEM OPTION (2 OF 4)

#	DESCRIPTION	PART No.	QTY	U/M
1	TANK, BLACK WATER 25 GAL	035-0925	1	EA
2	SENDER, WASTE 9" #TS-09	026-0605	1	EA
3	BRACKET, FUEL TANK 4-HOLE	029-0388	2	EA
4	SCREW, #14 x 1" PPHSMS	080-0940	4	EA
5	TAPE, FUEL TANK SUPPORT	021-0425	9	FT
6	CLAMP, T-BOLT 1-7/8" #70STBC18	021-0371	1	EA
7	CLAMP, 1 1/4" HOSE	021-0035	3	EA
8	BOOT, HOSE CLAMP	030-0864	3	EA
9	HOSE, 1-1/2" ODORSAFE	022-0146	REF	
10	HOSE, 3/4" BLACK PVC	022-0046	REF	
11	HOSE, 1" BLACK PVC	022-0047	REF	

FIGURE J-23: 318V GRAY WATER SYSTEM OPTION (3 OF 4)

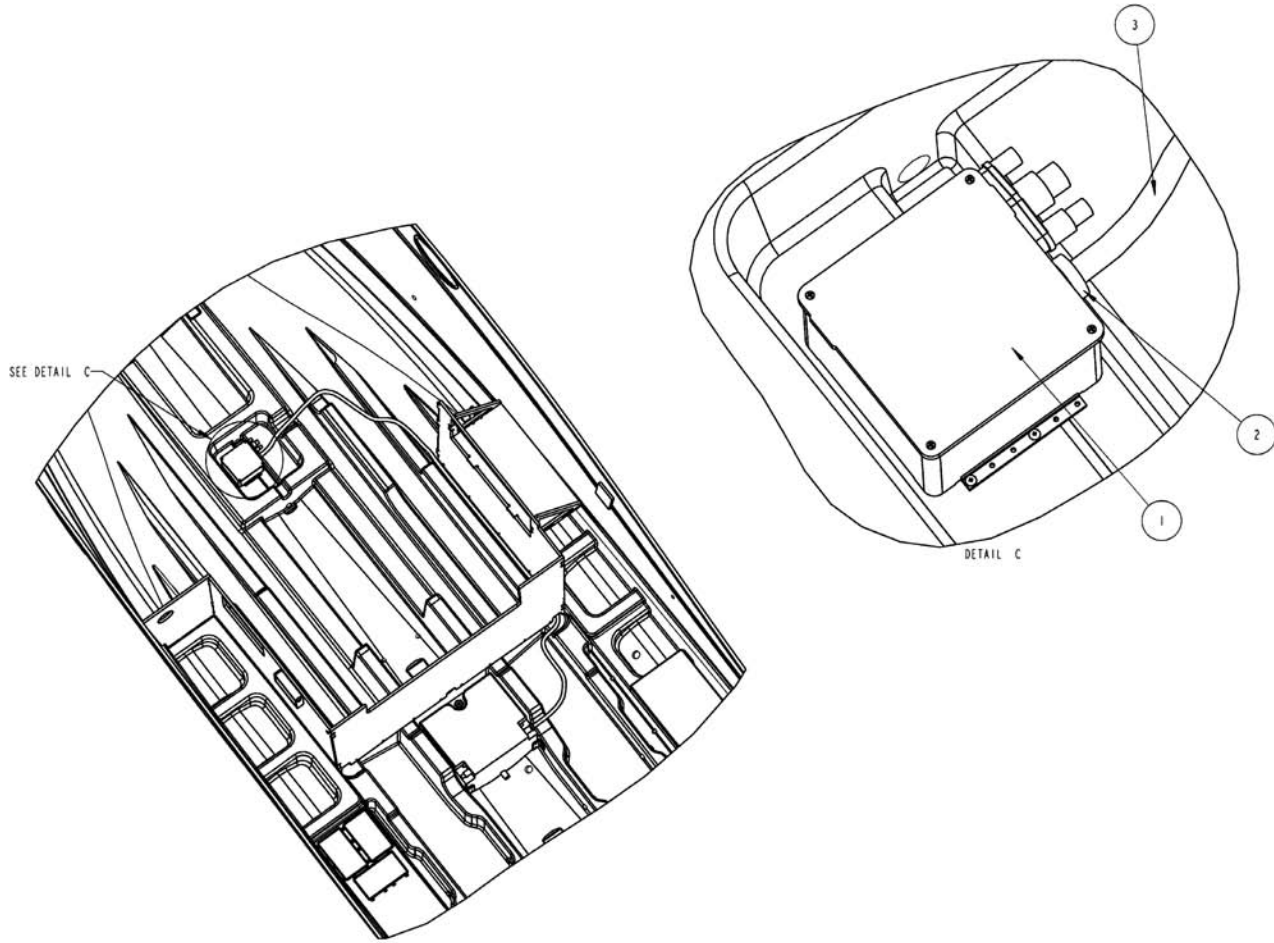

#	DESCRIPTION	PART No.	QTY	U/M
1	SUMP, SHOWER 800gph	026-0629	REF	
2	CLAMP, 1-1/4" HOSE	021-0035	REF	
3	HOSE, 3/4" BLACK PVC	022-0046	REF	

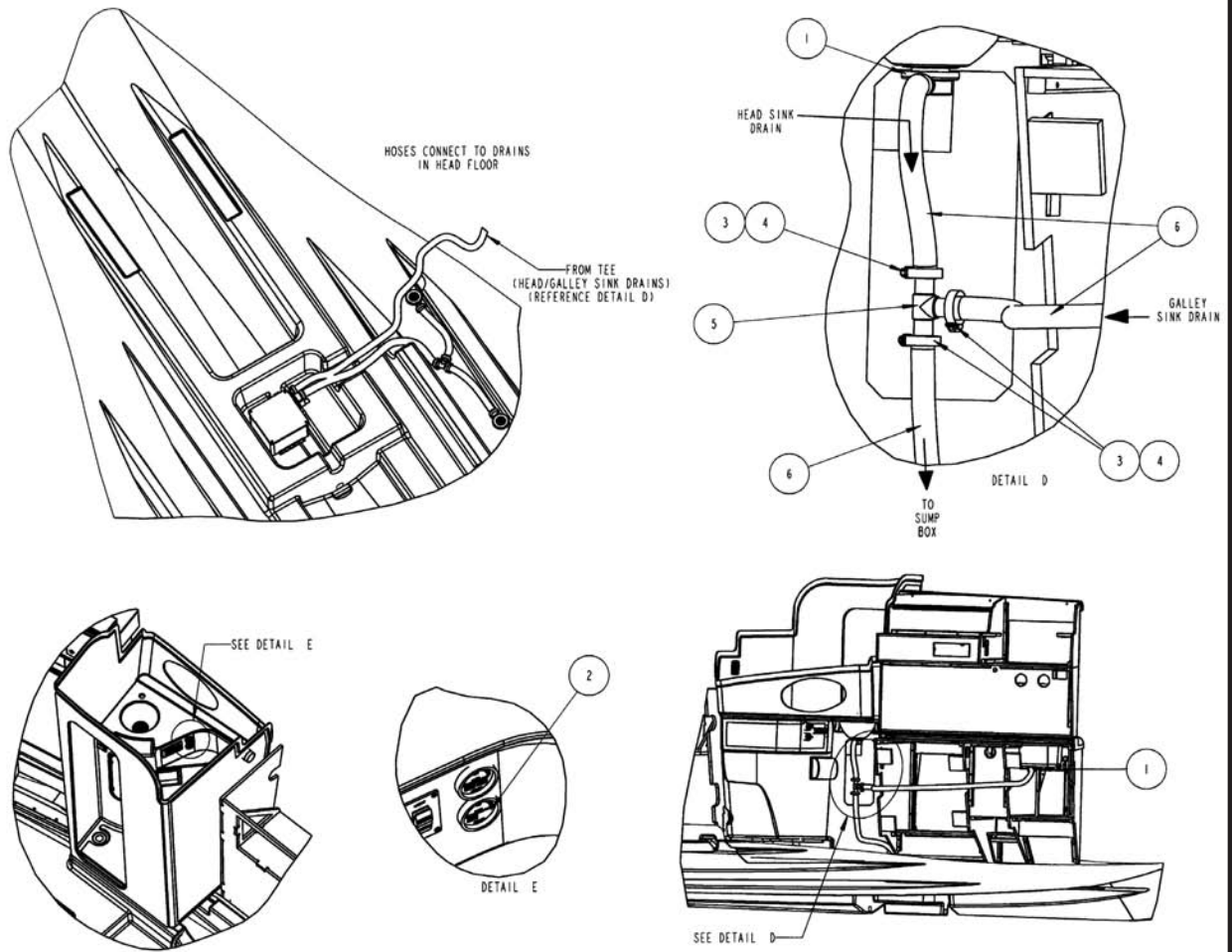
FIGURE J-24: 318V GRAY WATER SYSTEM OPTION (4 OF 4)

#	DESCRIPTION	PART No.	QTY	U/M
1	DRAIN, SINK #101045-00	035-0225	REF	
2	GAUGE, HOLDING DISPLAY #LLM-1 WASTE	024-0515	1	EA
3	CLAMP, 1 1/4" HOSE	021-0035	3	EA
4	BOOT, HOSE CLAMP	030-0864	3	EA
5	TEE, 1" ALL BARBED PLASTIC	035-0252	1	EA
6	HOSE, 1" BLACK PVC	022-0047	REF	

FIGURE J-25: 318V OVERBOARD DISCHARGE SYSTEM OPTION (1 OF 2)

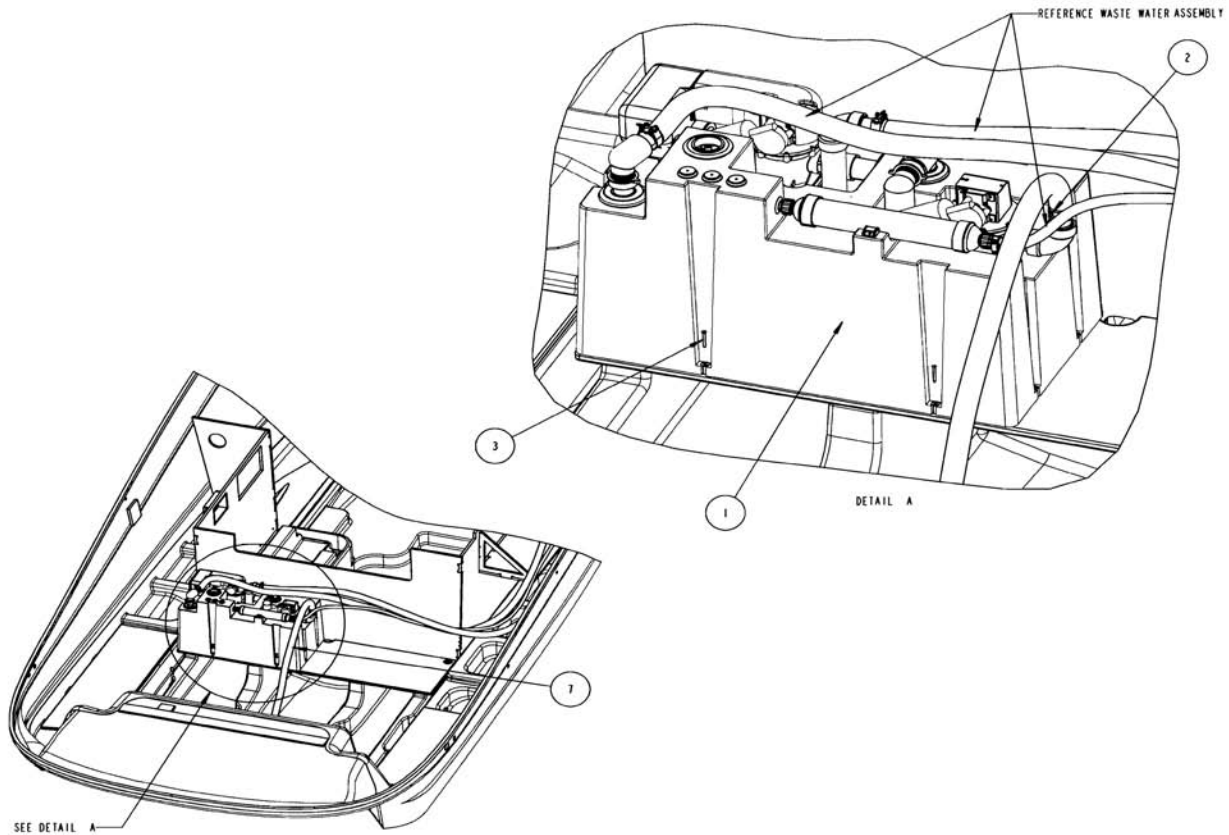

#	DESCRIPTION	PART No.	QTY	U/M
1	VACUFLUSH HLD TANK SYSTEM OB DIS 27.5	035-1394	1	EA
2	CLAMP, T-BOLT 1-7/8" #70STBC18	021-0371	1	EA
3	SCREW, #10 x 1-1/2" POHSM5	080-0032	8	EA
4	HARNES ASS'Y, DISCHARGE BONDING	027-1518	1	EA
5	HARNES ASS'Y, 78" BONDING #10 AND 3/8"	027-2634	1	EA
6	CAULK, 1/4" BEAD BELOW WATERLINE	084-0175	18	IN
7	HOSE, 1-1/2" ODORSAFE	022-0146	8	FT

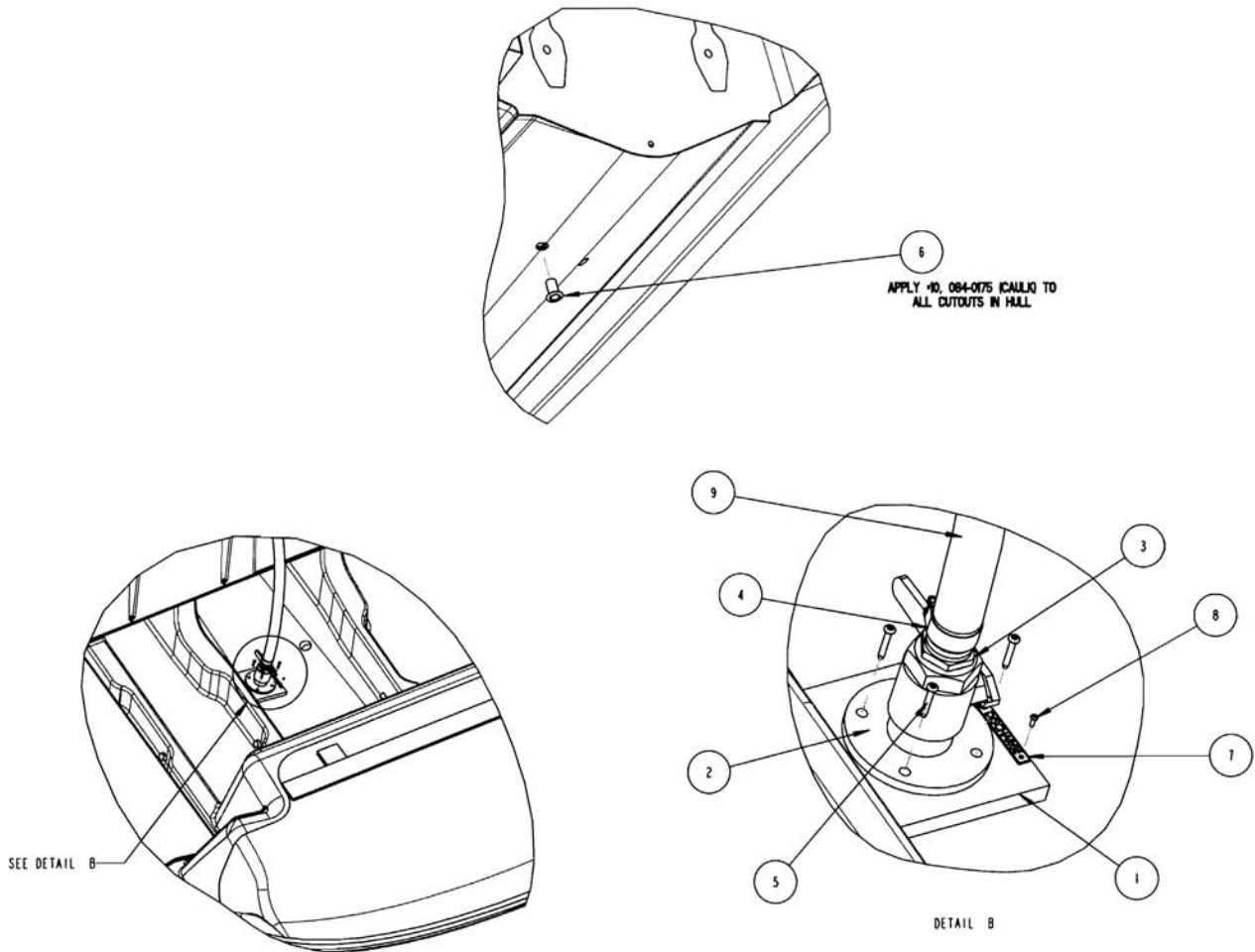
FIGURE J-26: 318V OVERBOARD DISCHARGE SYSTEM OPTION (2 OF 2)

#	DESCRIPTION	PART No.	QTY	U/M
1	SHIM, OVERBOARD DISCHARGE	100-22159	1	EA
2	SEACOCK, 1-1/2"	035-0105	1	EA
3	HOSE BARB, 1.5 MPT X 1.5 HB	035-0263	1	EA
4	CLAMP, T-BOLT 1-7/8" #70STBC18	021-0371	1	EA
5	SCREW, #12 x 1-1/2" PPHSMS	080-0041	4	EA
6	THRU HULL, 1-1/2" BRONZE	035-0204	1	EA
7	PLATE, HEAD DISCHARGE	056-0183	1	EA
8	SCREW, #6 x 1/2" PPHSMS	080-0010	2	EA
9	HOSE, 1-1/2" ODORSAFE	022-0146	REF	
10	CAULK, 1/4" BEAD BELOW WATERLINE	084-0175	A/R	

K - 1 ENGINE COMPARTMENT VENTILATION

All Four Winns Vista® models are equipped with engine compartment ventilation. This system is designed to meet or exceed the requirements (in effect at the time of manufacture) of the US Coast Guard, the National Marine Manufacturers Association, and the American Boat and Yacht Council.

A. Natural Ventilation System

This system includes air intake and exhaust components. The exhaust ducting reaches to the lower bilge area. This provides adequate air movement while underway and during bilge blower operation.

B. Forced Air Ventilation

All Four Winns Vista® models are equipped with an electric bilge blower. The bilge blower provides the ventilation required prior to starting the engines and while at idle. See Section H - Electrical Systems for blower operation instructions.

 **WARNING**

Before starting the engine(s) or generator, operate the engine compartment bilge blower for four (4) minutes. Then check the engine compartment for gasoline vapors. ALWAYS operate the bilge blower while the engines are at idle or the generator is in use. Failure to comply could cause explosion and thereby inflict serious injury or death.

 **WARNING**

Fumes can come from batteries while charging. A concentration of hydrogen fumes can be explosive under the right conditions. Ensure to follow the above warning.

NOTICE

A gas vapor detector is a monitor which will alert the operator of an accumulation of gasoline fumes in the engine compartment. It is optionally available on the 318 Vista® models. DO NOT rely solely on detectors or similar equipment. ALWAYS conduct a physical inspection of the engine compartment.

C. Engine Ventilation System Maintenance

Periodic inspection and cleaning of the ventilation ducts is necessary to ensure adequate air circulation. A buildup of leaves, twigs, or other debris can severely reduce ventilation. Be sure bilge water does not accumulate to a level that would obstruct the ventilation ducts.

Blower operation can be tested by placing a hand over the vents. DO NOT rely on the sound of the blower. Be sure a substantial amount of air is being exhausted by the bilge blower. Check the bilge blower system often, preferably before each cruise.

K - 2 CABIN VENTILATION

The 318 Vista® cabins are equipped with deck hatches for ventilation. The aft cabin window also opens to provide ventilation. The cabin side windows (portlight) on these Vista® models may be opened to provide additional ventilation.

 **WARNING**

Failure to properly ventilate the boat while the engines or generator are operating may permit carbon monoxide to accumulate inside of the cabin. Refer to Section E-2 - Engine Exhaust and Section B-2 - Carbon Monoxide for additional information.

Screens and blinds for the forward deck hatches are a standard feature. This “layered” deck hatch system allows the screens and blinds to be slid to the desired position with ease. Also, storage for the screens and blinds are built into the screen/sun/shade system. See Figure K-1.



Figure K-1: Layered Deck Hatch Screen/Sun/Shade System

NOTICE

Be sure deck hatch(s) is secured while underway. Damage to the hatch may result.

K - 3 HULL DRAINAGE SYSTEMS

A. Transom Drain

A transom drain with plug is provided in the engine compartment to allow water drainage. When boat is out of the water, the boat and cradle should be positioned so any bilge water accumulation during dry storage will flow towards the transom.

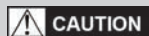

Be sure the drain plug is securely in place prior to launching the boat. Upon shipment of the boat, the drain plug is usually taped to the steering wheel.

B. Bilge Pumps

Forward and aft bilge pumps are provided in the bottom of the hull to remove miscellaneous water accumulations that might occur during normal boating or weather conditions. The aft bilge pump is controlled by the BILGE PUMP switch located on the port helm switch panel. Refer to Section H for further information regarding bilge pumps.

The bilge pumps are equipped with an automatic switch to control pump operation. As the water level rises, the automatic float switch will activate the pump. Separate circuit breakers are provided on the battery switch to supply power directly from the “SHIP SYSTEMS” battery to the forward and aft bilge pumps regardless of battery selector switch position.

NOTICE

While at rest, any bilge water accumulation may flow forward. DO NOT allow bilge water to accumulate. Damage to the engine or other components may result. Periodically operate the bilge pump to remove bilge water accumulation.

When leaving the boat unattended for long periods of time or during excessive rain storms, it is a good idea to check on the boat for excessive water accumulation. Be sure the bilge pumps and automatic float switches are operating properly. The operating time of the bilge pumps will be limited to the battery capacity.

Periodically, clean the bilge pump strainers. DO NOT allow dirt and debris to clog the bilge pump intakes. Check operation of the bilge pump float switch often to ensure movement of the switch is not restricted by debris, portions of the hull, etc.

Wipe up any oil accumulation in the bilge prior to activation of the bilge pumps. Pumping oil overboard will pollute the water, and is subject to fine.

After winterization of the fresh water systems, be sure the bilge area, bilge pumps and associated hoses are thoroughly dry. Damage to the hull, bilge pumps and other equipment could occur if water is allowed to freeze in the bilge. Refer to the manufacturers literature included in the owner’s packet for additional information.

C. Sump

A sump box is installed in the floor, just forward of the aft cabin. See the 318 Vista® locator drawing at the back of this manual. It is equipped with an automatic float switch and will pump water overboard or into the grey water tank (if available). Refer to Section J-2D on using the shower and for additional information on sump pump operation.

D. Bilge Compartment Drainage

Certain bulkhead areas of Four Winns® boats are sealed in accordance with US Coast Guard regulations effective at the date of manufacture. Drainage is provided and water can be removed with the bilge pump.

E. Cockpit Drainage

The 318 Vista® models incorporate a fiberglass self-bailing cockpit. This feature minimizes water entry to the bilge or engine compartment areas by providing means for water to be drained overboard.

Periodically open all engine hatches and clean the aft bilge compartment. Be sure the drains, tubes and fittings are clean and free of leaves, dirt, or other debris.

L - 1 GALLEY EQUIPMENT

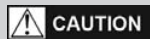

Care must be exercised while around stoves and other appliances. Keep children away from burners.

Care must be exercised while around stoves and other appliances. Keep children away from burners.

A. Electric Stove

An electric stove with dual burners is standard on the 318 Vista® cruiser models. See Figure L-1 for stove and other appliance locations. A circuit breaker (RANGE) is provided in the 120 Volt AC cabin electrical panel. Refer to the Section H of this manual and the manufacturer's literature included in the owner's packet for operation and safety procedures.

B. Microwave Oven

A microwave oven is standard on the 318 Vista® models. The circuit breaker on the 120 Volt AC cabin electrical panel must be activated and the boat must be connected to dockside power or utilize the generator in order to operate the microwave. Refer to the manufacturer's literature provided in the owner's packet.

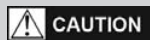

Do not restrict air flow while microwave is in use, or damage to microwave oven or cabinet may result.



Figure L-1: 318V Galley

C. Refrigerator

A refrigerator is standard equipment. The refrigerator is designed to operate efficiently on AC Shore Power (120 volt or 220VAC - international) or battery power (12 volt). The refrigerator will automatically transfer to 12 volt operation when dockside power is not available and the 12 volt refrigerator breaker is on.

Most refrigerator models have a thermostat that will maintain the temperature desired. According to the refrigerator manufacturer's operations manual, select the temperature setting by turning the thermostat dial to the various numbered positions. The refrigerator may be turned off by turning the thermostat to the "OFF" position. See the manufacturer's literature included in the owner's packet for specific information on the model used in your Vista®.

Care should be exercised while operating the refrigerator on the 12 volt system. The refrigerator requires a substantial amount of current. Excessive current draw can severely drain a battery through extended use.

On certain models a magnetic strip is used inside the seal of the refrigerators. The magnetic strip allows the seal to draw tight to the inside of the refrigerator when the door is closed. Also, make sure retaining latch is in place to secure refrigerator door while underway.

L - 2 REFRESHMENT CENTER

A refreshment center is available on the 318 Vista® models. The refreshment center comes with a solid surface countertop, trash receptacle, drink holders (not shown) and sink with swivel spout faucet. Your choice of an icemaker or refrigerator is available. See Figure L-2.



Figure L-2: 318V Cockpit Refreshment Center

The cockpit refrigerator (if applicable) operates automatically on 120 volt AC or 12V DC power supply. When both power sources are supplied to the refrigerator, it defaults to AC. When the refrigerator is disconnected from shore power (when AC power is no longer available) the refrigerator switches to DC operation.

The cockpit refrigerator runs continuously and does not utilize water. Unlike the icemaker, no winterization is required. Please follow the manufacturer's instructions regarding the use, care and maintenance of the refrigerator. These instructions are found in the owner's packet.

The icemaker operates on 120 volt (220 volt on 50 Hertz models) AC power and will only function when plugged into dockside power or when the generator is running. The icemaker is controlled by the Cockpit Icemaker/Refrigerator Circuit Breaker on the main cabin electrical panel. Refer to Section H - Electrical Systems for more information.

To operate, make sure the unit is plugged in and the main water supply is on. Ensure the "ice bin arm" is in the DOWN position. The first ice cubes may take approximately 45 minutes to be made.

To control the temperature, turn the temperature control clockwise to make it colder or turn control counterclockwise to make it warmer. Remember, a warmer setting increases the rate of ice production (maximum ice is achieved at the warmest setting). Refer to the manufacturer's information in the owner's packet for further information regarding your particular model.

To winterize, unplug the unit and follow the normal cleaning, maintenance and winterization instructions included in the manufacturer's manual. For instructions on winterizing with antifreeze, refer to Section J-7 on Water System Maintenance in this manual.

 **CAUTION**

Thoroughly flush the water supply lines and system prior to initial use, and at least once each season. This will remove any additives and possible contaminants present in the system.

The materials from which the components of the water system are made may give the water supply a peculiar taste, especially when new. This condition is normal and can be reduced substantially by adding a water filter to the system such as one produced by PuriTek™. The taste will completely dissipate in time.

L - 3 ENTERTAINMENT

A. Stereo System

Four Winns offers a AM/FM/CD stereo, an amplifier, tweeters, and a subwoofer as standard equipment along with stereo remote with display feature at the helm. See Figure L-3. Speakers are installed within the interior cabins and exterior cockpit areas to provide excellent sound quality. In addition, the cabin and cockpit speakers can be faded in or out depending on the effect desired. For stereo operation, please refer to the manufacturer's manual included in the owner's information packet.



Figure L-3: Stereo & DVD Player Locations

Also, the 318 Vista® comes equipped with a satellite stereo receiver (domestic only). Please see your Four Winns dealer for information and activation.

Available options include 6-disc CD changer, iPod/MP3 ports for the cabin and the cockpit and an additional stereo remote with display feature at the transom. Please consult your Four Winns dealer for details and availability.

B. TV and DVD Player

A flat screen TV and DVD player with remote is standard on the 318 Vista® models. It uses an internal speaker only. The TV is not wired into the stereo speaker system. Please read the manufacturer's

information on the TV and DVD player in the owner's packet. See Figure L-3.



Figure L-4: Television

A dockside phone/cable TV inlet is installed on the 318 Vista®. This dockside connection for telephone/cable TV is located in the shore power inlet panel located in the transom systems locker. A TV/cable/phone panel assembly is installed inside the upper galley behind the flat screen TV. See Figure L-5.

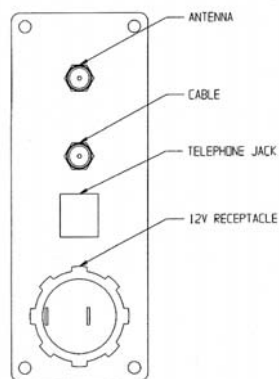

Figure L-5: TV/Cable/Phone Panel Assembly

L - 4 AIR CONDITIONING

Air conditioner/heater provides either cooling or heating and is a standard feature. The unit operates on 120 volt (220 volt on 50 hertz on export models) AC power. The output of the air conditioner may be found on our website at www.fourwinns.com. Be sure the appropriate shore power cord is connected or the generator is running whenever the air conditioning is to be used.

The air conditioning breakers must be turned on to activate the air conditioning unit. These breakers are at the dockside power inlet panel and at the AC/DC panel, AC Systems 2. Depending upon humidity, the air conditioner will condense 5 to 15 gallons of water a day and this water drains into the sump pump.

The air conditioner is located behind the companion-way cabinet, underneath the port AC cabinet. Air conditioner vents are located throughout the cabin to provide good air circulation. There is a vent in the head for additional air circulation on most models. The vents are adjustable to change air flow direction and can be closed. See Figures L-6 - L-13 and the locator drawings in the back of this manual.

The seawater inlet (seacock) valve is identified with a plate inscribed with the words "Air Conditioner Seawater". Access to the seacock is gained through an access lid in the aft/mid cabin.

NOTICE

In order to use the air conditioner, you must first open the seawater inlet valve - seacock (handle parallel to the flow of valve). When not using the air conditioner be sure to close the valve/seacock.

Refer to the Figure L-6 for the location of the air conditioning control panel. Please read the manufacturer's information on the air conditioner contained in the owner's packet for operation instructions.



Figure L-6: Air Conditioner Control Panel Location

NOTICE

Most air conditioners utilize surface water as the cooling medium. Prior to using the air conditioning, the boat must be in the water and the seacock to the air conditioning water intake must be in the open position. The air conditioning seacock for water intake is below the aft cabin access panel. Operating air conditioners without proper cooling water will cause damage to the air conditioning system.

Air conditioners utilized in Four Winns® Vista® models are equipped with reverse cycle heat. Thus, some heat effect can be derived from the unit. It must be noted that the amount of heat that can be obtained is limited by the temperature of the raw cooling water pumped through the system. When the water temperature drops to 40 degrees Fahrenheit, the output is about 50% of the maximum. At 36 degrees Fahrenheit, the output is very low.

NOTICE

During cold conditions, an alternate or supplemental heating system should be used.

Clean the sea water strainer often. Also, clean the return air filter screens, located behind the louvered doors and grills, at least once a month.

To winterize, refer to the manufacturer's literature included in the owner's packet.

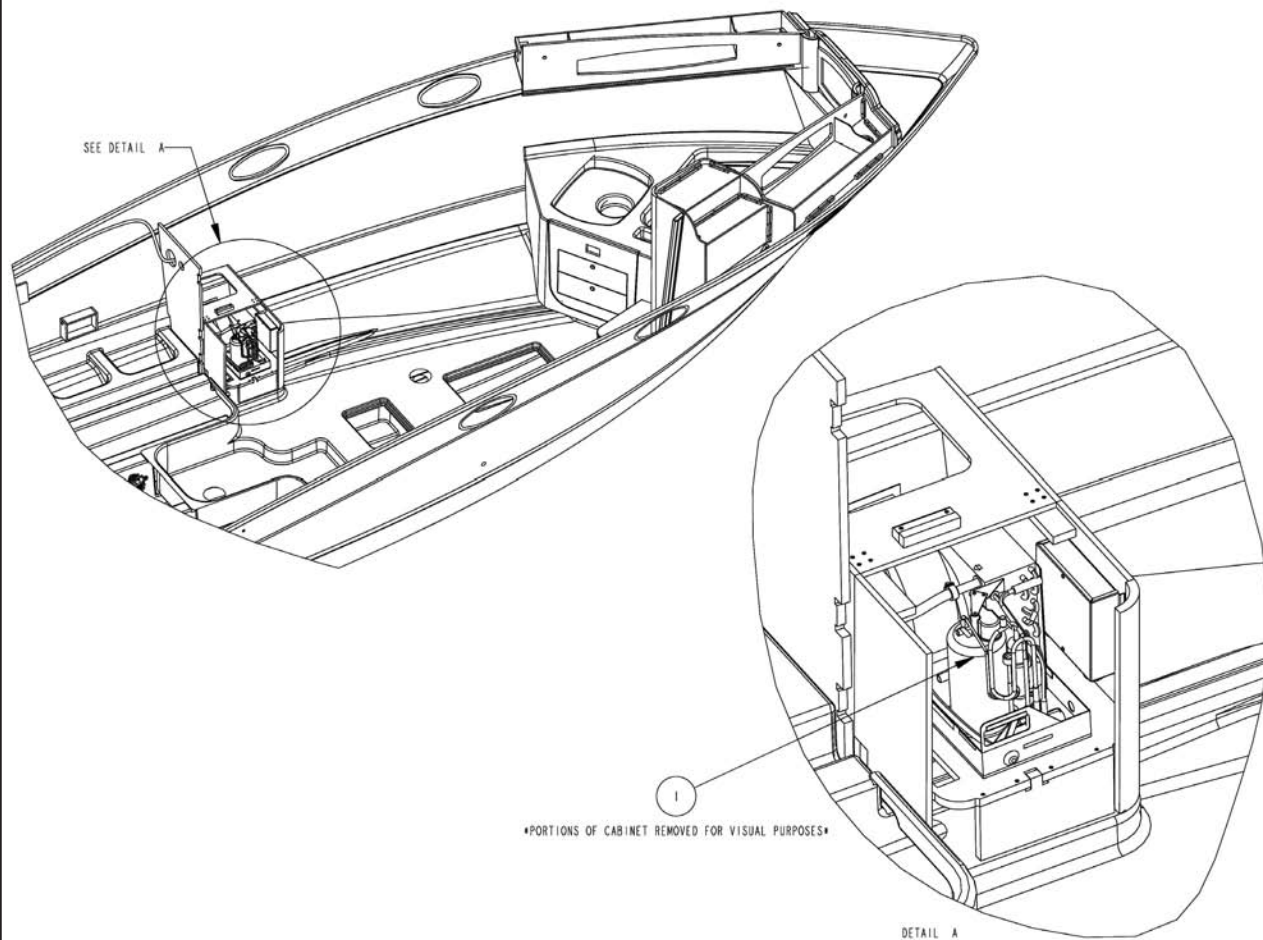
FIGURE L-7: 318V AIR CONDITIONING SYSTEM (1 of 8)

#	DESCRIPTION	PART No.	QTY	U/M
1	AC KIT, 110V 10K BTU 308V "05"	065-1587	1	EA
2	BAG, MARINCO SHORE POWER	028-1035	1	EA
3	HARNES ASS'Y, AIR CONDITIONING 328V	027-1536	1	EA
4	CORD, DOCKSIDE POWER	065-0056	1	EA
5	ANTIFREEZE, NON-TOXIC, 55 GAL DRUM	084-0043	1	GL
6	ADAPTER, 30 AMP TO 15 AMP	028-0073	1	EA

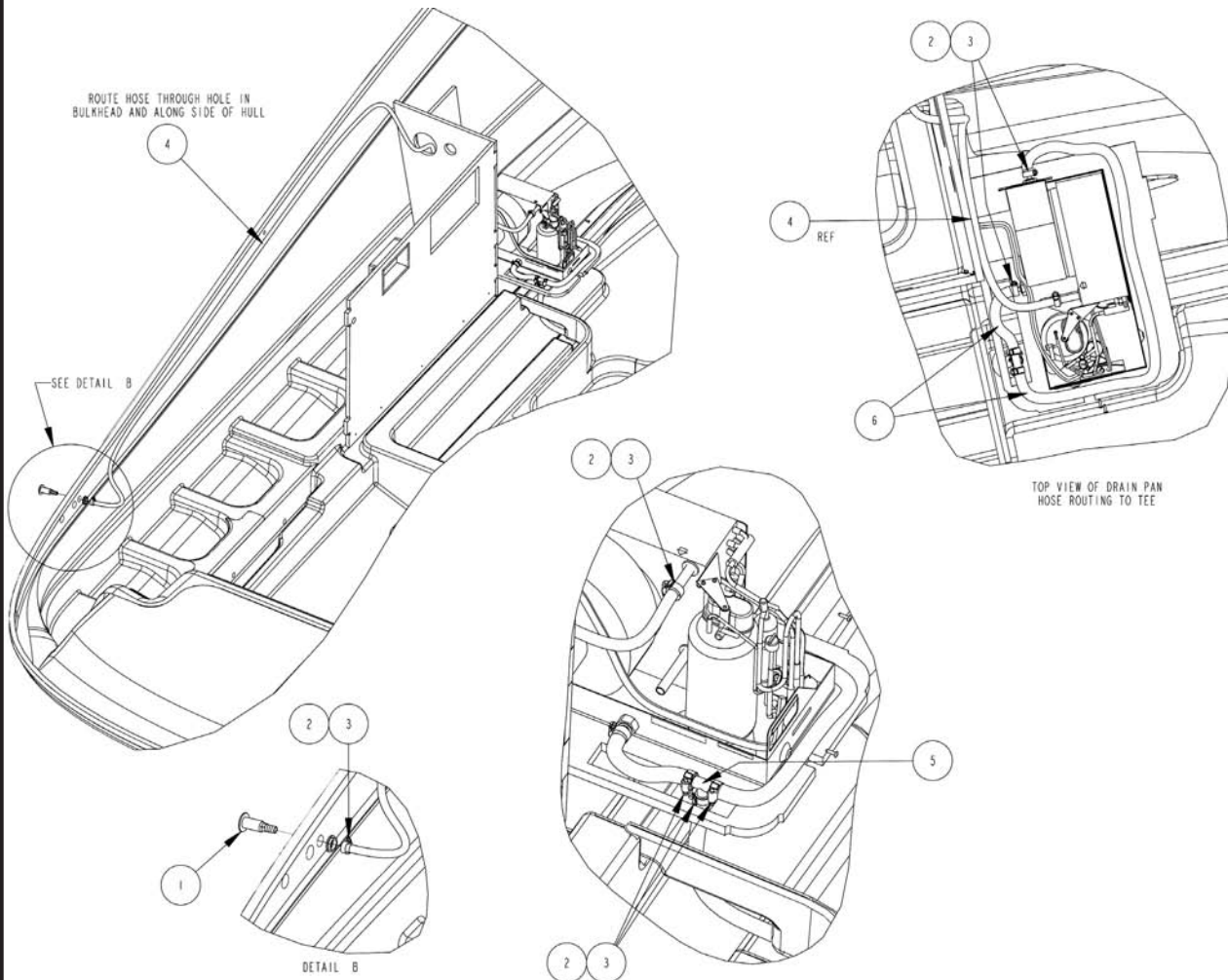
FIGURE L-8: 318V AIR CONDITIONING SYSTEM (2 of 8)

#	DESCRIPTION	PART No.	QTY	U/M
1	THRU HULL, 5/8" S.S.	035-1270	1	EA
2	CLAMP, 5/8 INCH #10H FUEL VENT	021-0031	7	EA
3	BOOT, HOSE CLAMP	030-0864	7	EA
4	HOSE, 5/8" BAITWELL #164-0580	022-0006	15	FT
5	TEE, 3/4" ALL BARBED	035-0302	1	EA
6	HOSE, 3/4" WATER #148-0340	022-0029	4.5	FT

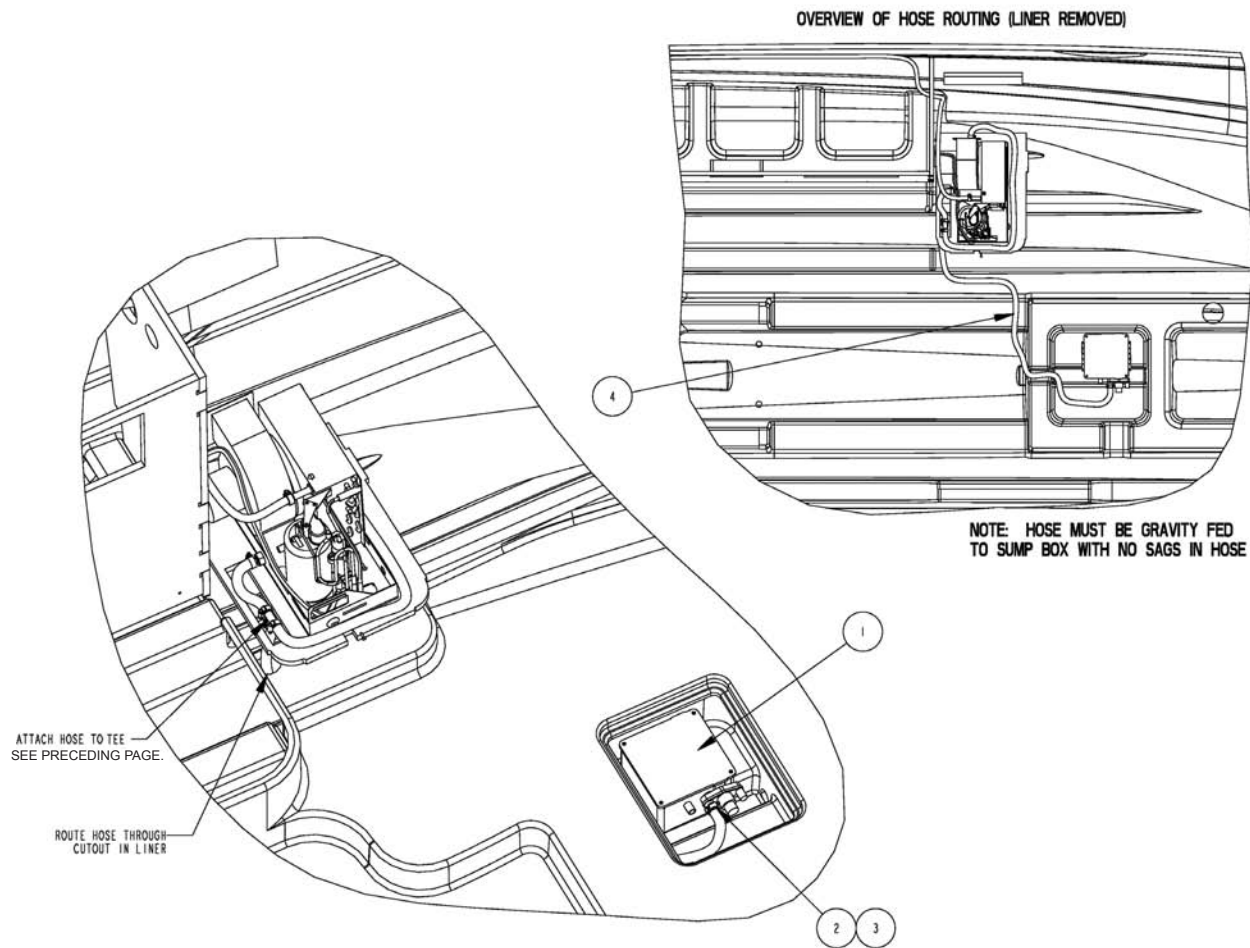
FIGURE L-9: 318V AIR CONDITIONING SYSTEM (3 of 8)

#	DESCRIPTION	PART No.	QTY	U/M
1	SUMP, SHOWER 800gph	026-0629	REF	
2	CLAMP, 5/8 INCH #10H FUEL VENT	021-0031	1	EA
3	BOOT, HOSE CLAMP	030-0864	1	EA
4	HOSE, 3/4" WATER #148-0340	022-0029	6	FT

FIGURE L-10: 318V AIR CONDITIONING SYSTEM (4 of 8)

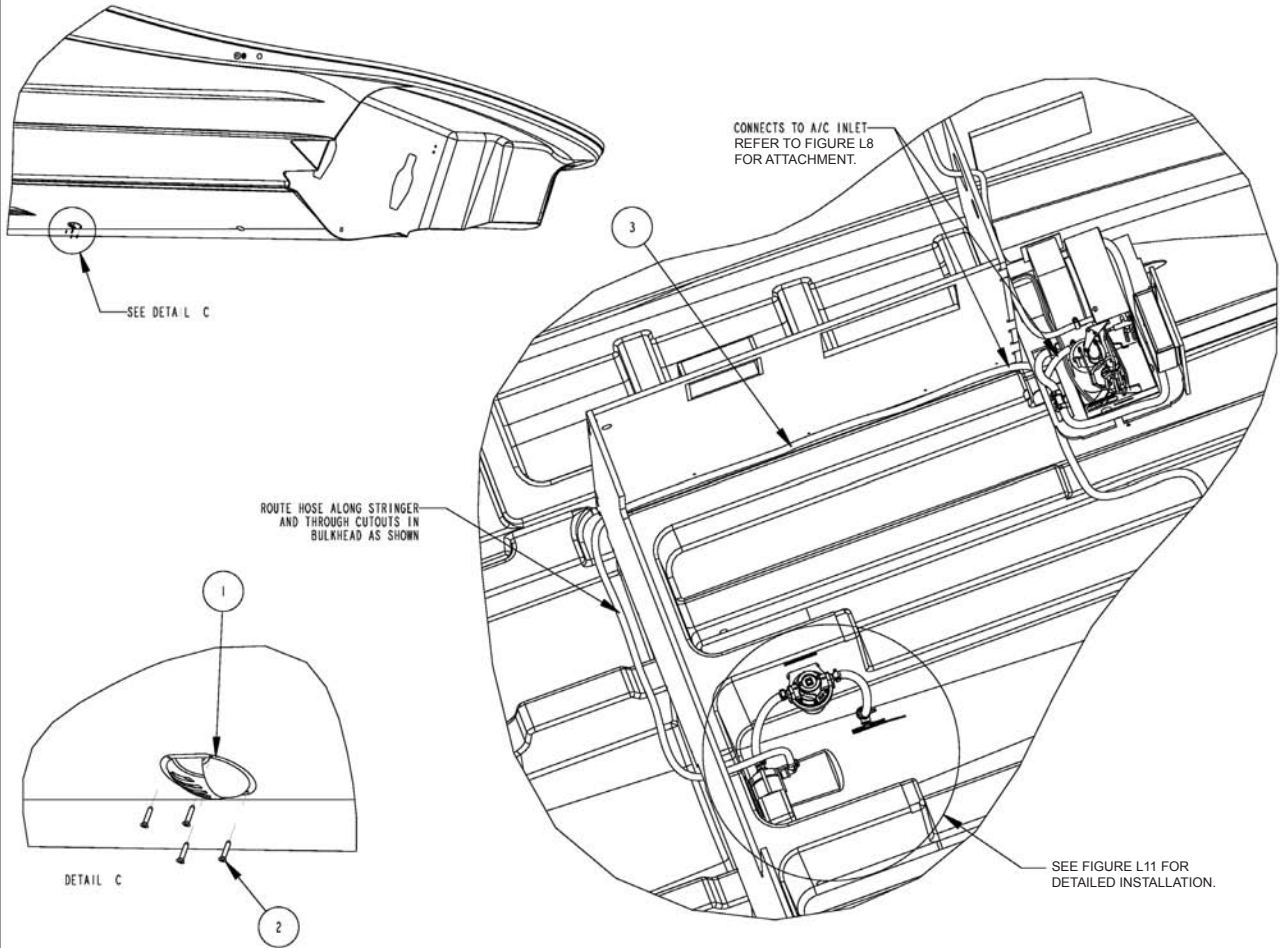

#	DESCRIPTION	PART No.	QTY	U/M
1	STRAINER, SCOOP 3/4"	035-0206	1	EA
2	SCREW, #8 x 3/4" POHSMS	080-0022	4	EA
3	HOSE, 5/8" WASTE #148-0580	022-0013	10	FT

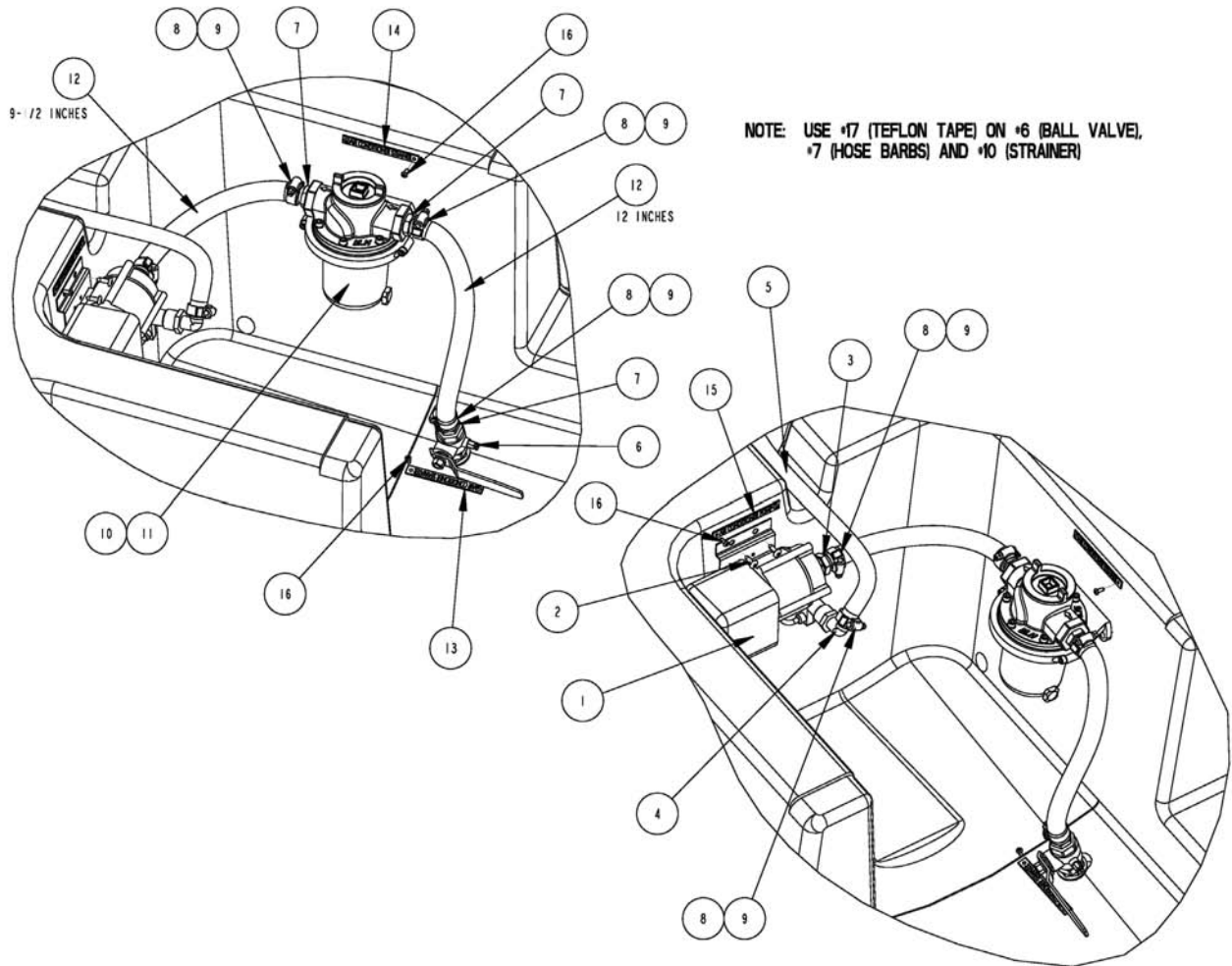
FIGURE L-11: 318V AIR CONDITIONING SYSTEM (5 of 8)

#	DESCRIPTION	PART No.	QTY	U/M
1	A/C WATER PUMP	065-1587	REF	
2	SCREW, #12 x 3/4" PTHSMS	080-0369	4	EA
3	HOSE BARB, 3/4 MPT X 3/4 BARB (BLACK)	035-0095	1	EA
4	ELBOW, 3/4 MP X 5/8 HB 90 DEG	035-0245	1	EA
5	HOSE, 5/8" WASTE #148-0580	022-0013	REF	
6	VALVE, BALL 3/4"	035-0118	1	EA
7	HOSE BARB, 3/4 MPT X 3/4 HB	035-0327	3	EA
8	CLAMP, 5/8 INCH #10H FUEL VENT	021-0031	5	EA
9	BOOT, HOSE CLAMP	030-0864	5	EA
10	STRAINER, WATER 3/4"	035-0248	1	EA
11	SCREW, #10 x 3/4" PTHSMS	080-0033	3	EA
12	HOSE, H.W. WATER 3/4"	022-0201	2	FT
13	PLATE, AIR CONDITIONER SEAWATER	056-0105	1	EA
14	PLATE, AIR CONDITIONER STRAINER	056-0106	1	EA
15	PLATE, AIR CONDITIONER PUMP	056-0119	1	EA
16	SCREW, #8 x 1/2" PPHSMS BLACK	080-0024	6	EA
17	TAPE, TEFLON 1/2" X 260"	084-0009	.25	EA

FIGURE L-12: 318V AIR CONDITIONING SYSTEM (6 of 8)

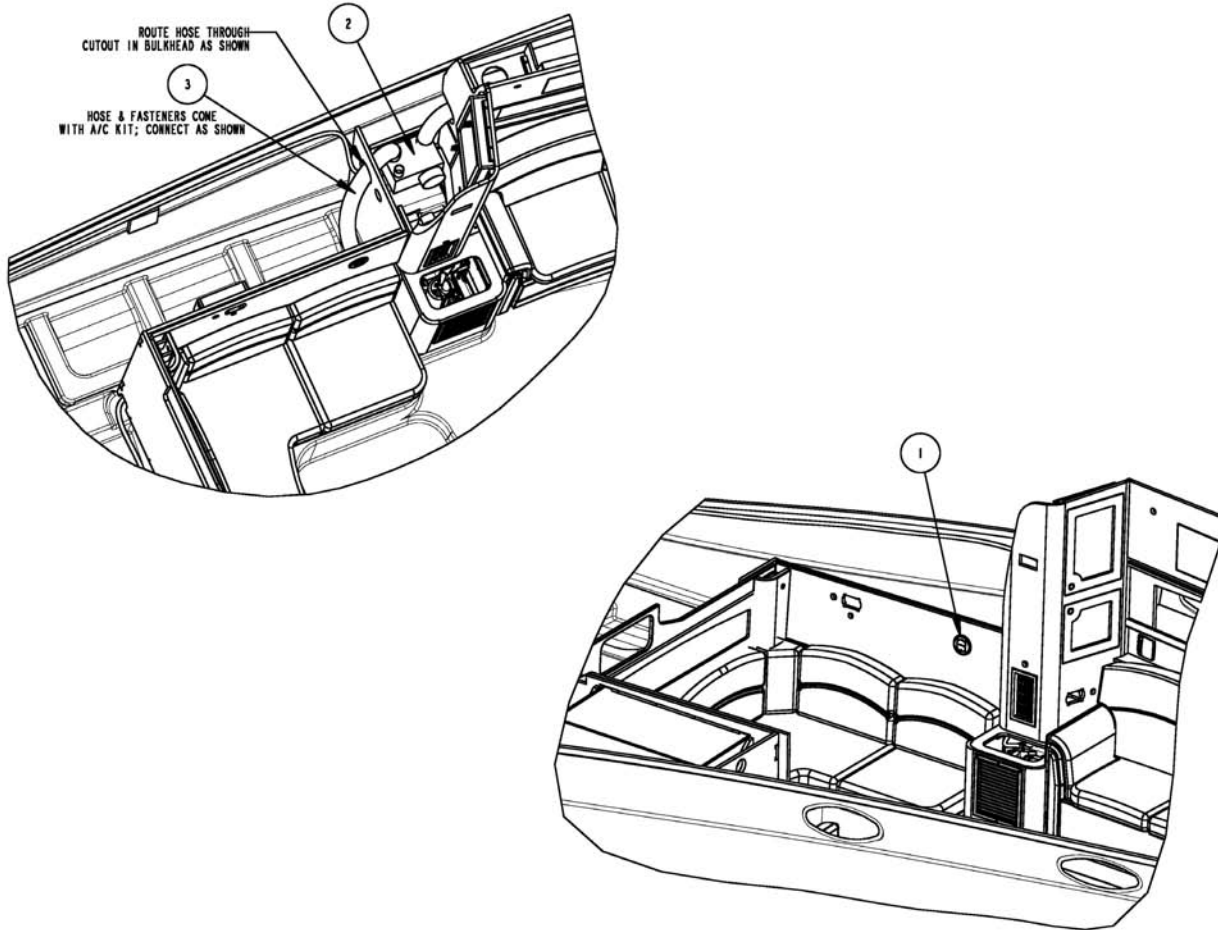

#	DESCRIPTION	PART No.	QTY	U/M
1	BLACK 3" ROUND GRILL	065-1587	REF	
2	PLENUM BOX, A/C BLOWER	065-1587	REF	
3	A/C KIT HOSE	065-1587	REF	

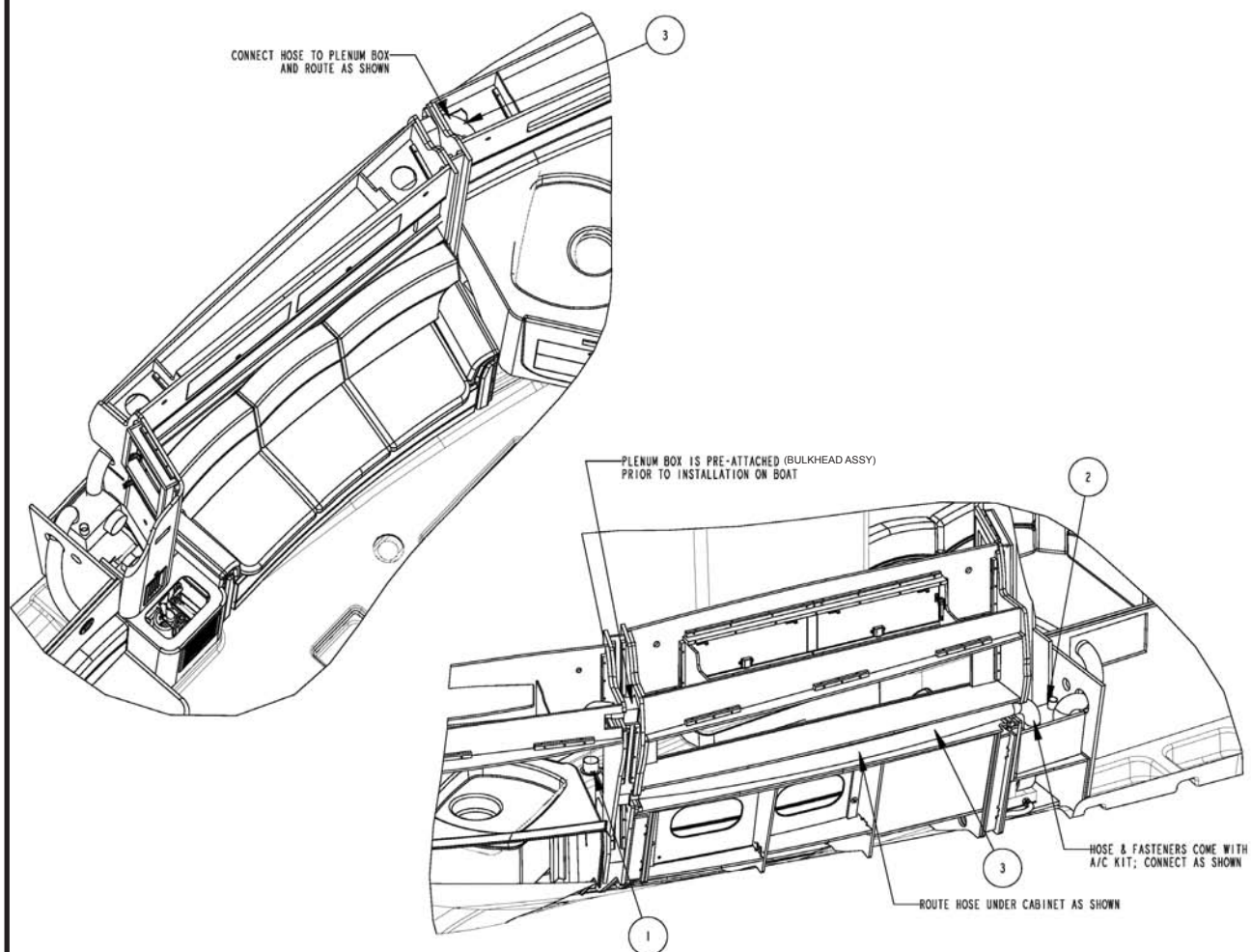
FIGURE L-13: 318V AIR CONDITIONING SYSTEM (7 of 8)

#	DESCRIPTION	PART No.	QTY	U/M
1	BLACK 3" ROUND GRILL	065-1587	REF	
2	PLENUM BOX, A/C BLOWER	065-1587	REF	
3	A/C KIT HOSE	065-1587	REF	

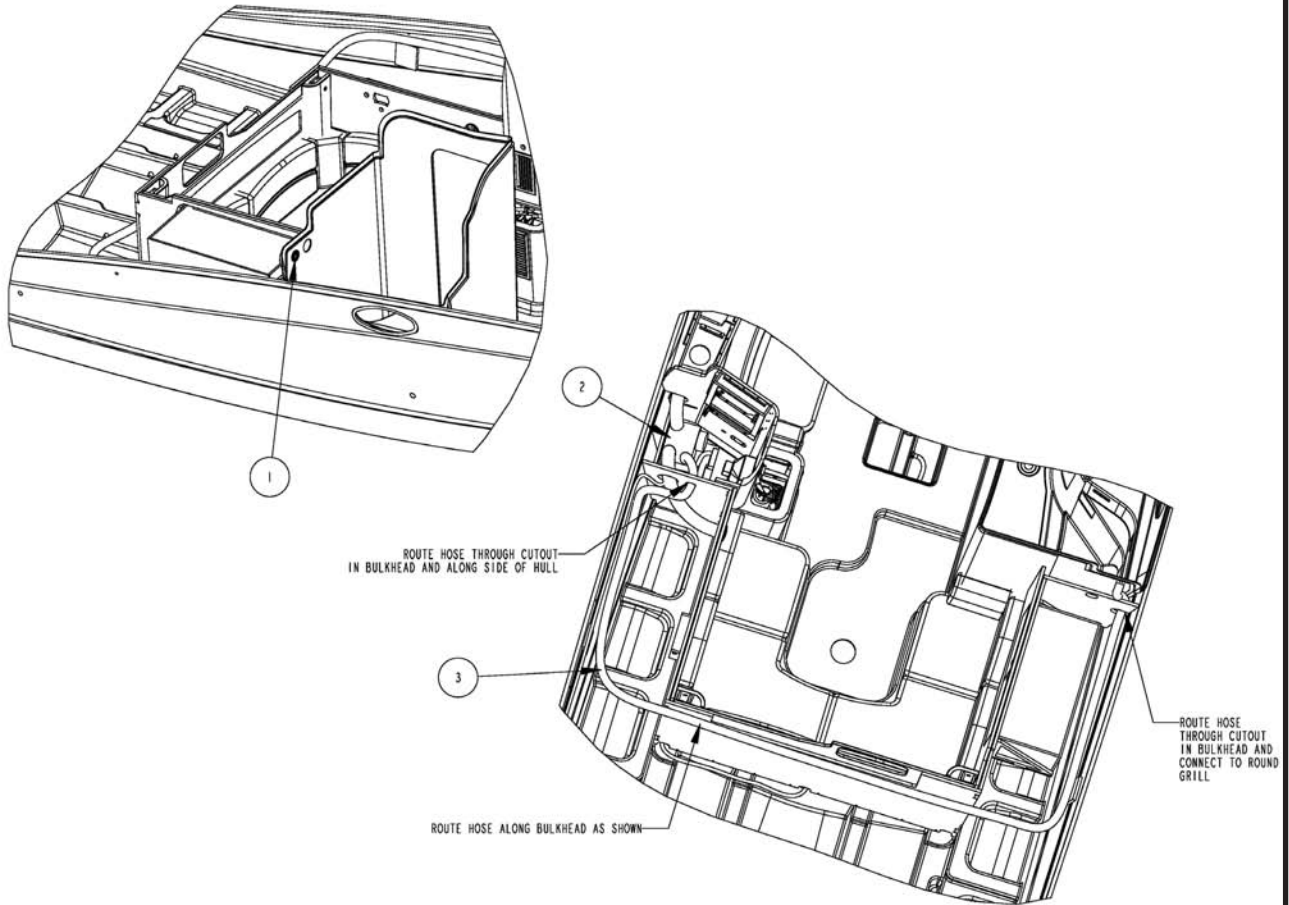
FIGURE L-14: 318V AIR CONDITIONING SYSTEM (8 of 8)

#	DESCRIPTION	PART No.	QTY	U/M
1	WHITE ROUND GRILL 2"	065-1587	REF	
2	PLENUM BOX, A/C BLOWER	065-1587	REF	
3	A/C KIT HOSE	065-1587	REF	

M - 1 RAILS & DECK HARDWARE

Hand and bow rails have been installed to provide security for passengers while outside the cockpit area (i.e. swim platform and bow areas). Limiting passenger movement while underway is recommended. All those on board should be safely seated whenever possible. Additional care must be taken when in rough seas or foul weather. Access to the foredeck should be through the foredeck hatch when running in adverse conditions.

 **WARNING**

Four Winns does not recommend occupying the foredeck during bad weather or on rough seas. DO NOT use walk-thru instead use deck hatches and only if absolutely necessary during any bad weather or on rough sea conditions.

The rail system and hardware fittings have been selected and installed to perform specific functions. Fenders or mooring lines should not be secured to the rails or stanchions. Be certain that a clear lead exists when running dock lines or an anchor line. A line inadvertently threaded around a stanchion or over the rail could cause damage.

The majority of the hardware installed is made of stainless steel. See Figure M-1. Regardless of the type of hardware used, periodic maintenance is necessary.

Intermediate Lifeline



Figure M-1: Stainless Steel Fittings

Cleaning the hardware with a nonabrasive cleaner will help keep the original shine and beauty. Stainless steel hardware, while quite durable, can become

superficially rusted. This can be controlled by cleaning the fittings and applying a coat of wax. Any future rusting can be removed by polishing and rewaxing.

NOTICE

All fittings must be periodically inspected for loosening, wear, and damage. Problems should be corrected immediately!

The cleats that have been installed are specifically designed and are intended to be used as mooring cleats. Their purpose is for securing the vessel to a dock, pier, mooring, or anchor.

 **WARNING**

Four Winns® boats are not equipped with any hardware designed for towing purposes. The mooring cleats that are installed on the boat are not to be used for towing another vessel or having the boat towed. Refer to Section A - Operation for additional precautions regarding grounding and towing.

M - 2 TRANSOM DOOR

A transom door is provided and allows access from the cockpit to the swim platform. A slide latch which is magnetic is used to secure the transom door closed while underway. Since the latch is magnetic, while at rest, it can hold the door in the open position for convenience. To prevent a possible man overboard situation, make sure the transom door is secure before each cruise. See Figure M-2.

Transom Door



Figure M-2: Transom Door

 **DANGER**

To prevent personal injury, swim platform must not be occupied and transom door must be closed while engines are running.

WARNING

Prevent falls overboard. Close, latch, and stay inside gate(s) while underway.

CAUTION

To prevent personal injury, DO NOT sit on or lean against the transom door.

M - 3 COMPANIONWAY DOOR

The 318 Vista® models have a one-piece sliding companionway door on a track. The companionway door includes a built-in screen for added ventilation and comfort. See Figure M-3. A hinged stop at threshold secures the door in the open position.



Figure M-3: Companionway Door

NOTICE

To prevent damage to the companionway track, the companionway door must be moved slowly and carefully during use.

A lock is provided on the companionway door to secure the cabin.

NOTICE

Always secure companionway door before operating the boat. Rough water or significant wake could cause the companionway door to slam shut and break. Acrylic plastic is impact resistant but in extreme cases it can crack and/or the track could become damaged if not secured.

To clean acrylic plastic (plexiglass):

- 1) Rinse with plenty of water to wash off as much dirt as possible.
- 2) Using your bare hand, along with plenty of water, feel and remove any dried on dirt or mud.
- 3) Wash using a soft, grit free cloth or sponge and mild, nonabrasive soap or detergent.
- 4) Blot dry using a clean, damp chamois.

NOTICE

Never use a dry cloth, duster, glass cleaning solutions or citrus cleaner on acrylic plastic.

See Section Q - 9 for additional information on the care of acrylic plastic.

M - 4 WINDOWS

A. Windshields and Cabin Windows

The windshield consist of tempered safety glass and cabin port lights consist of plexiglass. The windshield frame consists of a painted or polished aluminum. An optional stainless steel windshield header is available.

A walk-thru windshield is standard. Steps are provided between the companionway and helm station to allow easy access through the walk-thru windshield opening. See Figure M-4.



Figure M-4: Access to Walk-Thru Windshield

⚠ WARNING

Four Winns does not recommend occupying the foredeck during bad weather or on rough seas. DO NOT use walk-thru instead use deck hatches and only if absolutely necessary during any bad weather or on rough sea conditions.

⚠ CAUTION

Make sure deck hatches are closed or be aware of their location when using walk-thru and moving around the foredeck to prevent possible injury.

⚠ CAUTION

We recommend you close and secure the walk-thru windshield while underway. Damage to the windshield could result.

⚠ CAUTION

Secure walk-thru windshield with strap (if applicable) when in open position. Securing the walk-thru windshield will help prevent the windshield from accidentally slamming closed due to high wind and/or wake condition, thus reducing the chance of damage to windshield or injury.

Windshields made of tempered glass can be cleaned with automotive glass cleaners or dishwashing soap and water. Ensure that a clean cloth is used to prevent scratching the glass.

Aluminum can be cleaned with similar products or with nonabrasive cleaners such as Fantastik™.

NOTICE

Read the label before using any product. DO NOT use abrasive cleaners.

B. Plexiglass

Plexiglass (acrylic plastic) is used for port holes, companionway door assemblies, transom doors, sliding storage doors, electrical panel doors, cabinets and cabin windows. Plexiglass will scratch easily and must be handled with care.

To clean, follow the instructions located in Sections M-3 and Q-8. DO NOT use paper towels. They will scratch the plexiglass.

Plexiglass or plastic polish may also be used. Read the label first before using any cleaning product.

NOTICE

DO NOT use harsh chemicals or strong cleaning solutions on plexiglass. The surface can be etched, scratched, disfigured, or clouded. See Section Q - 9 Acrylic Plastic - (Plexiglass).

M - 5 FOREDECK HATCHES

The foredeck hatches consist of a translucent plexiglass. The hatch is supported by one locking hinge and can be secured in a partially open position for ventilation. See Figure M-5. Follow the cleaning directions for plexiglass described in Sections M-3 and Q-9 of this manual.

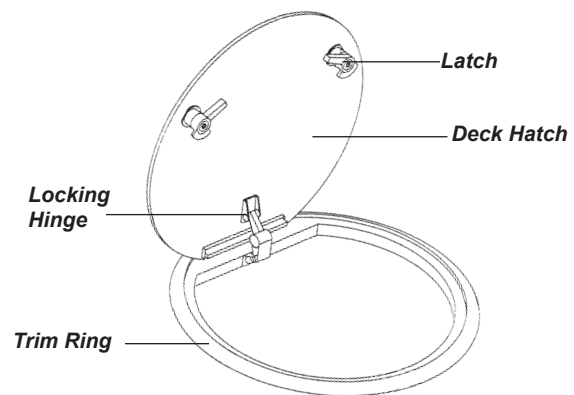

Figure M-5: Forward Deck Hatch

Screens and blinds for the forward deck hatches are a standard feature. This “layered” deck hatch system allows the screens and blinds to be slid to the desired position with ease. Also, storage for the screens and blinds are built into the screen/sun/shade system. See Figures M-6 and M-7.



Figure M-6: Screen Portion of Screen/Sun/Shade System



Figure M-7: Shade Portion of Screen/Sun/Shade System

NOTICE

Be sure deck hatch(s) is secured while underway. Damage to the hatch may result.

M - 6 SWIM PLATFORM

Four Winns provides an aft, integrated swim platform on the 318 Vista® models. For better footing, a skid-resistant surface is provided. The ladder is angled with wide step pads and deep reaching for ease of use and comfort. When not in use the ladder can be folded and concealed in a ladder storage compartment of the swim platform under the ladder lid. A grab handle is located in the ladder lid to assist while boarding. See Figures M-8 and M-9.

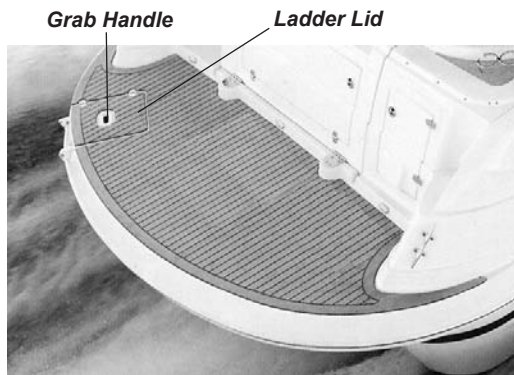

Figure M-8: Swim Platform



Figure M-9: Boarding Ladder

WARNING

To prevent personal injury, DO NOT use the boarding ladder or swim platform while the engines are operating or the boat is in motion. Engines must be off when using the swim platform or boarding ladder. See Preface for specific label information.

WARNING

Keep hands and fingers away from ladder supports and hinges to prevent injury.

NOTICE

Always secure the ladder before boating. Damage to the ladder may otherwise result.

M - 7 COCKPIT STORAGE

Storage compartments are provided throughout the cockpit area. See Figure M-10. Storage space is design to be easily accessible.

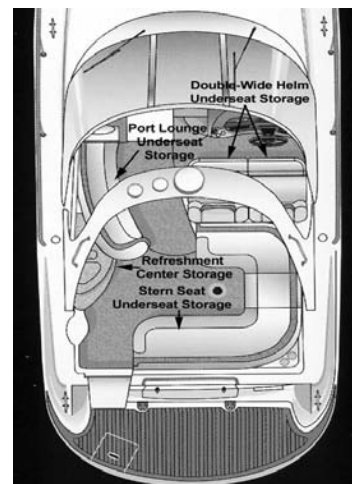

Figure M-10: Cockpit Storage Compartments

M - 8 TRANSOM STORAGE LOCKER

The transom storage provides storage for such things as dock fenders, personal floatation devices, dockside power cord(s) etc. The storage lockers use latches for easy access. To open, lift the handle. The latches are flush mounted to prevent injury or accidental opening. See Figure M-11.



Figure M-11: Transom Storage Locker

M - 9 BOW PLATFORM

The 318 Vista® models are designed with an integrated bow platform. This bow platform provides a functional base for anchoring. The anchor is stored in the anchor chute of the platform. The anchor roller provides support for the chain/rope and anchor. See Figure M12. Refer to [Chapman's Piloting, Seamanship and Small Boat Handling](#) or local anchorage authority for anchor type and size recommendation.

⚠ WARNING

To prevent a possible man overboard situation, NEVER stand on, or try to utilize the bow platform in any way while the boat is underway.

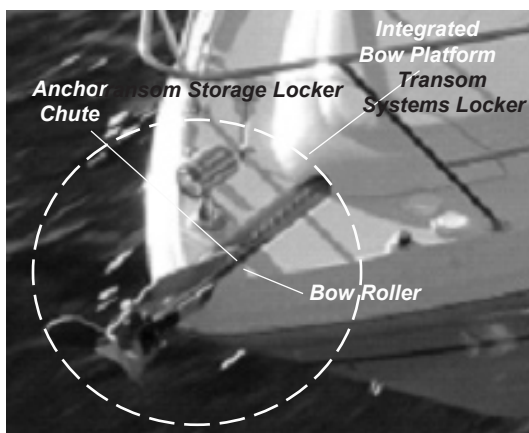

Figure M-12: Integrated Bow Platform

M - 10 WINDLASS

An optional windlass is an electrically controlled winch mechanism for retrieving the anchor available on the 318 Vista® model. The mechanical winch portion is mounted inside the anchor locker, at the bow. See Figure M-13. The windlass can be controlled by a set of foot pads (electrical switches) mounted on the foredeck or it can be operated from the helm. A circuit breaker on the battery switch is provided to protect the windlass from a possible overload situation. A circuit breaker at the 12VDC helm breaker panel is also provided to protect the windlass circuit. Refer to the manufacturer's literature included in the owner's packet for windlass operation.

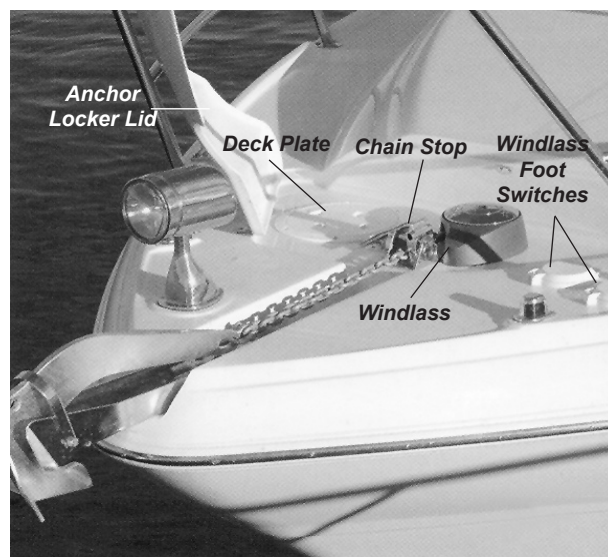

Figure M-13: Windlass

Along with the windlass comes an anchor, rope and chain. The anchor line is stored in the anchor line locker located underneath the anchor locker. The locker keeps the line secure while underway and keeps the deck clear of unsightly anchor line when docked. A deck plate provides access to the anchor line locker. See Figure M-13.

⚠ WARNING

To prevent personal injury, keep clear of the windlass at all times.

WARNING

Always be sure to raise and secure the anchor prior to operating your boat. Failure to raise and secure anchor before getting underway could result in severe injury or damage to boat from rebounding anchor.

WARNING

Always utilize the chain stop provided with the windlass/bow roller combination. The chain stop prevents the anchor from accidentally releasing while the boat is moving thus preventing damage to the boat or possible injury or death to individual(s) aboard the boat. See Figures M-11 and M-12.

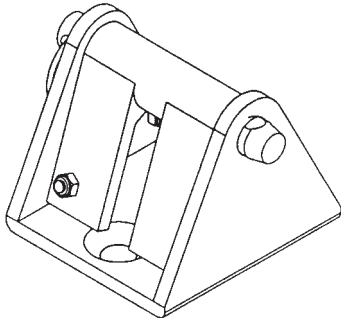

Figure M-14: Chain Stop

M - 11 RADAR ARCH

The radar arch is swept forward in design. This presents a sleek look while providing an adequate platform necessary for installation of radar equipment. See Figure M-15. Four Winns offers certain optional navigation packages that may include radar equipment. Refer to Section E-8L Navigational Equipment for additional information. Please consult with your Four Winns dealer regarding inquiries and availability.



Figure M15: Radar Arch

M - 12 SPOTLIGHT

Four Winns offers an optional remote controlled spotlight for the 318 Vista® model. The spotlight uses an electric motor and helm switch controls to direct the spotlight's beam. See Figure M16. Refer to the spotlight manufacturer's literature included in the owner's packet.



Figure M16: Remote Spotlight

M - 13 ENGINE HATCH w/ ELECTRIC LIFT

The 318 Vista® models feature an engine hatch with an electric lift or screw jack. The screw jack lifts and lowers the engine day hatch by pressing the switch located on the dash. The screw jack runs off the engine batteries. See Figure M17.

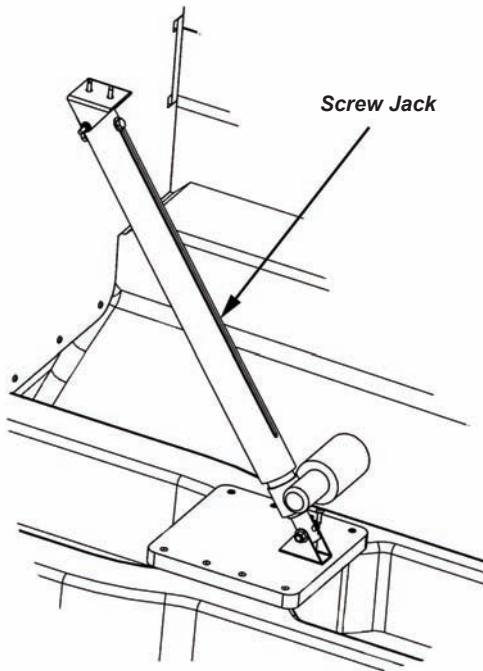

Figure M17: Electric Lift for Engine Hatch

To raise the engine hatch:

1. Remove the cockpit table or aft fill-in cushion (if currently installed).
2. Press the engine hatch switch (“UP”) to raise the engine hood to its open position.

The engine hatch can be lifted manually if the screw jack fails to operate.

To raise the engine hatch manually:

1. Carefully raise the engine hatch using the hand hold and prop open.

 **CAUTION**

Without properly propping engine hatch open during manual lifting procedure, engine hatch may fall resulting in possible personal injury and/or damage to engine hatch and components.

 **CAUTION**

The engine hatch can be lifted without the screw jack. Use care and proper lifting techniques to prevent possible back injury.

 **CAUTION**

Do not have person(s) sitting in stern seat or on engine hatch while attempting to raise engine hatch. Possible injury to person(s) and/or damage to engine hatch and components may result.

NOTICE

Never operate or trailer your boat with the engine hatch in its open position. Doing so could result in damage to the engine hatch, hardware, and/or loss of cushions.

To lower the engine hatch:

1. Press the engine hatch switch (“DOWN”) to lower the engine hatch to its closed position.
- 1b. If lowering engine hatch manually, raise the hatch slightly and remove the engine hatch support (if applicable). Carefully lower the engine hatch to its closed position. Do not allow it to just drop to the deck.

 **CAUTION**

If closing the engine hatch manually, do not allow the engine hatch to “slam” shut. Allowing the engine hatch to “slam” shut can damage the fiberglass and/or cause bodily injury.

2. Reinstall the cockpit table or aft fill-in cushion (if so desired).

NOTICE

Cushions, if not properly stored and secured, can blow out of the boat.

N - 1 INTERIOR SEATING
A. Couch and Dinette Table

The couch in the main cabin converts to converts to a berth. The couch seat cushion base slides out and a filler cushions (not shown) go between the cushions and backrest of the couch. Convenient storage is located underneath the couch seat base. See Figures N-1 & N-2.



Figure N-1: Couch



Figure N-2: Underseat Couch Storage

A cherry dinette table is standard on 318 Vista® models and is located in the main cabin. The table leg height is easily adjustable. In essence, you can turn the dinette table into a coffee table when desired and back again. It can be raised or lowered approximately 10 inches (25.4 cm) utilizing “gas assistance”. Table bases are “flush” mounted for convenience. The table leg is removable. Rotating the leg while lifting will ease the removal. The dinette table is hinged for “fold-up” storage. The storage for the table and leg is found beneath the forward berth. See Figures N-3 and N-4.



Figure N-3: Dinette Table



Figure N-4: Dinette Table Storage

B. V-berth or Forward Cabin

Four Winns provides a forward and aft mattress for the v-berth/forward cabin area. An optional inner-spring mattress for the V-berth is available. The V-berth comes with a privacy curtain, under berth storage and hanging locker storage. See Figure N-5.



Figure N-5: Forward Berth w/ Optional Inner Spring Mattress

A private stateroom option provides a greater level of privacy. See Figure N-6.



Figure N6: Private Stateroom Option
(Note: Representative View - Models may vary).

NOTICE

The private stateroom option can not be retrofitted to an already existing standard cabin layout. This option must be ordered and built into the boat at Four Winns.

C. Mid Cabin (Aft Cabin) Berth

The mid cabin provides sleeping quarters with the use of filler cushions, a fill-in support and mid cabin table. Privacy can be obtained through the use of the privacy curtain. The mid cabin also includes a window with screen for ventilation. Storage in the mid cabin consists of an sidewall cabinet and beneath seat storage. Also, access lids are installed below mid cabin cushions for gaining access to and the servicing of various plumbing systems and other equipment. See Figures N7, N8 and N9.



Figure N7: Mid Cabin



Figure N8: Mid Cabin w/ Fill-In Cushions
Note: Fill-Ins are also Backrests

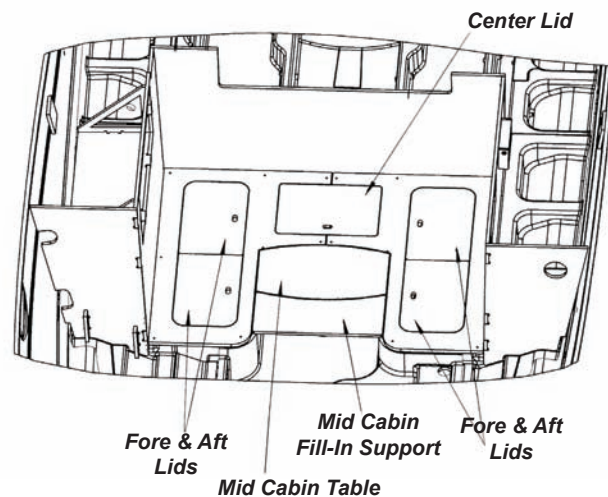

Figure N9: Mid Cabin Access Lids



To prevent personal injury, be sure the mid cabin fill-in support is secure before use.

N - 2 EXTERIOR SEATING

A. Helm Seat

The helm seat is adjustable and double wide so it can seat two people comfortably. A mechanical slider mechanism is mounted under the driver's seat. This allows the driver of the boat to adjust his portion of the helm seat to meet his or her needs. To adjust the helm seat, push the slider adjustment lever. Move the seat forward or aft to the desired position and then release to lock the seat into position. There is approximately six inches of adjustment available. The helm seat includes flip-up bolsters. By simply flipping up the bolster the driver and/or passenger is able to sit higher in the seat. This is designed to give the driver and passenger greater flexibility, increased visibility, and riding comfort. See Figures N10.



Figure N-10: Helm Seat & Bolster

 **WARNING**

DO NOT sit on the backrest portion of any cockpit seat. The operator could lose control of the boat or passengers could be thrown from the boat. The seat could also be damaged if excessive force is applied.

B. Stern Seat

The custom U-shape stern seat includes a fiberglass base. The U-shape seating arrangement continues around the back of the boat to create more usable seating area. Underseat storage is readily available under the hinged stern seat. Refer to Figures N-11 and N-12.

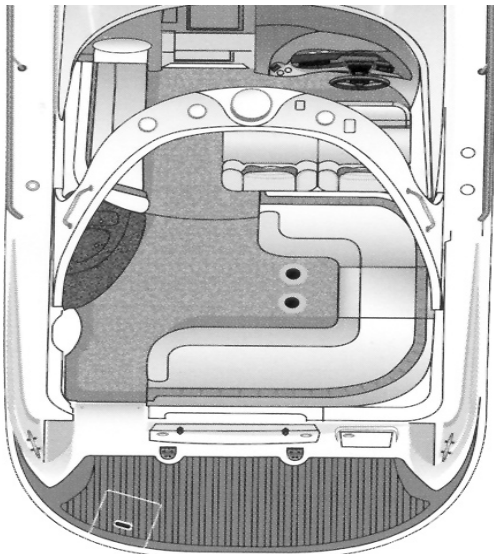

Figure N-11: U-Shape Stern Seating



Figure N-12: Under Seat Storage (Stern Seat)

Additionally, an aft fill-in seat cushion is an available feature. This feature extends the cushion area of the stern seat for such things as sunbathing, napping or overnight sleeping. Refer to Figure N-13.



Figure N-13: Aft Fill-In Cushion

To install:

1. Insert the fill-in legs (14" short legs) into the floor mounts.
2. Mount the aft cockpit table onto the fill-in legs. The aft cockpit table provides the support for the aft cushion.
3. Place the aft fill-in cushion on the cockpit table.

To remove the aft fill-in cushion, simply reverse the procedure.

C. Port Settee Lounge

A port side settee lounge provides seating capacity for two people. It is conveniently built into an integrated fiberglass base which also contains the refreshment center. Storage is provided underneath the removable seat cushion. See Figures N-14 and N-15.



Figure N-14: Port Settee Lounge



Figure N-15: Under Seat Storage - Port Settee Lounge

D. Cockpit Table

An aft cockpit table is standard. See Figure N-16. Table bases are “flush” mounted for convenience and safety.



Figure N-16: Aft Cockpit Table

To set up the cockpit table:

1. Insert the table legs (approximately 26.5" long) into the floor mounts.
2. Mount the cockpit table onto the table legs.

To remove the cockpit table simply reverse the procedure.

NOTICE

To prevent damage to cockpit table and/or cockpit interior ensure the cockpit table and legs are properly stored.

E. Deck Sunpads

The sunpads are optional. These cushions securely snap in place and provide comfort while sunbathing on the foredeck. See Figure N-17.



To prevent a possible man overboard situation, NEVER occupy the sunpads while the boat is underway. Use the sunpads when boat is at rest only.



Figure N-17: Sundek Pads

N - 3 INTERIOR UPHOLSTERY CARE

A. Cleaning Interior Fabric/Upholstery

The fabric used in the cabin should be treated the same as fabrics in your home. Periodic vacuuming and gentle cleaning will keep the fabric and upholstery clean and odor free. Spraying the fabric/upholstery with Lysol Spray Disinfectant™ will help retard mildew.

For vinyl care see N-4A.

A recommended "Cleaning Kit" includes:

- Westley's Clear Magic™ (for ordering information call 1-800-416-1600 or 800-321-8577; website address www.westleys.com)
- Fast & Easy Glass Cleaner™ (to locate the nearest distributor, call 800-537-8990)
- Tough Duty Cleaner™ (to locate the nearest distributor, call 800-537-8990)
- Clean, white towels
- Portable/Compact Deep Cleaner Vacuum (Bissell Spot Lifter™ or similar product)
- Air hose (if available)

To remove stains, please refer to the following list for recommended cleaners.

1. Basic Stains/Ink/Grease/Pencil/Dirt:

Westley's Clear Magic™

2. Adhesives/Teak Oil/Gum/Tar:

Tough Duty Cleaner™

3. Water Stains:

- a. While fabric is still wet, use a deep cleaner vacuum to go over the wet area. This will remove the stain from the fabric. It is always best to get the stain before it dries.
- b. For water stains that have dried, use a deep cleaner vacuum system. Follow the instructions that come with the deep cleaner system. Repeat if necessary.
- c. If this does not work we recommend a professional cleaning service. One such service is Service Master®. Please call 1-800-937-3783 for the Service Master location nearest you.

4. Tough Stains/Set Water Stains:

- a. Spray Westley's Clear Magic™ on the area, going two (2) inches around the stain or if possible, bring wetness to a break point, such as a bulkhead, etc. Spray water on the same area as directed on the bottle.
- b. Let set approximately five (5) minutes.
- c. Rub the area with a clean towel, rotating the towel as the stain is removed. As you rub, go a little beyond the wetness with the towel, flaring the edges.
- d. Use a deep cleaner type vacuum to remove excess wetness. Allow to dry.
- e. Repeat if necessary.
- f. If stain still persists, use a professional cleaning service.

B. Interior Carpets

Four Winns Vista® cruisers use a high quality interior grade carpeting. Interior carpeting should be cleaned in the same manner as the carpeting in your home. Vacuuming and occasional rug shampooing are recommended for extended life and appearance. Always conduct a colorfast check on a small area of carpet prior to applying the cleaning solution/shampoo on the entire carpet.

C. Privacy Curtains

After a season or more use and exposure, you may wish to remove the curtains. Dry cleaning is recommended. Most draperies can be taken down after removing the screw from the end of the curtain track. This screw may not be accessible on some models. Should this be the case, remove the screws securing the end of the track. The track is flexible and can be lowered to remove the end screws.

N - 4 EXTERIOR UPHOLSTERY CARE

A. Cleaning Vinyl

NOTICE

Vinyl upholstery should be cleaned and maintained in accordance with the manufacturer's recommendations and instructions.

The vinyl material used on the exterior upholstery should be cleaned regularly with warm water and a mild dish soap or Vinyl Finish Vinyl Cleaner® using a soft clean cloth, then rinse with a soft clean cloth. For dirt buildup, spray Vinyl Finish Vinyl Cleaner®, let soak for approximately ten (10) minutes, then gently scrub with a soft bristle brush. Be sure to thoroughly rinse the vinyl after washing with mild dish soap or Vinyl Finish Vinyl Cleaner® to remove all residue. Towel dry the vinyl. Periodic spraying of the seats with Lysol Spray Disinfectant™ will help retard mildew.

To further protect the vinyl from early degradation, use 303 Aerospace Vinyl Protectant®. Spray on, then wipe dry. 303 Vinyl Protectant should be applied every 3-5 weeks when boat is in use. Regular cleaning with mild soap and water or Vinyl Finish Cleaner will not remove the 303.

NOTICE

DO NOT apply vinyl protectants such as Armorall. The manufacturer does not recommend this product because it removes the oils present in vinyl that keeps vinyl soft.

A recommended "Cleaning Kit" includes:

- Ivory Dishwashing Liquid™ and water
- Clean, white towels
- Soft bristle brush
- Fantastik Spray Cleaner™
- Denatured Alcohol
- Hemisphere Ink Remover® - (for ordering information call 800-247-9901)
- Vinyl Finish Vinyl Cleaner® - (everyday cleaning & care, call 800-247-9901)
- 303 Aerospace Vinyl Protectant® - (for ordering information call 800-247-9901)
- Tough Duty Cleaner™ - (to locate the nearest distributor, call 800-537-8990)
- Ammonia and hydrogen peroxide

To remove stains, follow the general guidelines list and/or refer to the Step-by Step Cleaning Instructions table:

General Stain Removal Guidelines

1. Basic Stains/Grease/Pencil/Dirt:

Ivory (mild) Dishwashing Soap™ and water, or Fantastik Spray Cleaner™ applied with a medium-soft brush or Vinyl Finish Vinyl Cleaner® using a soft clean cloth, then rinse with a soft clean cloth.

2. Tough Stains/Adhesive/Teak Oil/Rust:

Tough Duty Cleaner™; rinse with soap and water or spray with Vinyl Finish Vinyl Cleaner®, let soak for approximately ten (10) minutes, then gently scrub with a soft bristle brush. Thoroughly rinse vinyl and dry.

NOTICE

To prevent possible damage to the vinyl, rinse with soap and water after applying the Tough Duty Cleaner™ or Vinyl Finish Cleaner®. Then rinse and dry.

3. Ink:

Denatured alcohol or Hemisphere Ink Remover®.

4. Mildew Stains:

To kill bacteria creating the mildew, vigorously brush the stained area with a 4-to-1 mixture of water and ammonia; rinse thoroughly with water and dry.

5. Tough Mildew Stains:

Apply a mixture of one (1) teaspoon ammonia, one-fourth (1/4) cup of hydrogen peroxide, and three-fourths (3/4) cup of distilled water; rinse with water and dry.

Step-by-step cleaning instructions			
Type of Stain	STEPS: 1,	2,	3
General Care	A	B	
Dirt Build-up	A	B	
Ballpoint ink*	E	B	A
Chewing gum	D	A	
Coffee, tea, chocolate	B		
Grease	D	B	
Household soil	A	B	
Ketchup	A	B	
Latex paint	A	B	
Lipstick	A	B	
Mildew or wet leaves*	C	B	A
Motor oil	B		
Oil-based paint	D	B	
Permanent marker*	E	B	C
Spray paint	B		
Suntan lotion*	A	B	
Tar / Asphalt	D	B	
Yellow mustard	A	B	C

Legend

A. Medium-soft brush, warm soapy water
Rinse / Dry

B. Vinyl Finish Vinyl Cleaner®
Rinse / Dry

C. One (1) tablespoon of ammonia; one-fourth (1/4) cup of water
Rinse / Dry

D. Wipe or scrape off excess (chill gum with ice before hand)

E. Hemisphere Ink Remover
Rinse / Dry

All cleaning methods must be followed by a thorough rinse with clean warm water.

Certain household cleaners, powdered abrasives, steel wool and industrial cleaners can cause damage and discoloration and are not recommended. Dry cleaning fluids and lacquer solvents should not be used as they will remove the printed pattern and gloss. Waxes should be used with caution as many contain dyes or solvents that can permanently damage the protective coating.

*Suntan lotion, tree pollen, wet leaves and some other products can contain dyes that stain permanently. Care should be exercised and boat covers should be utilized.

Step-By-Step Vinyl Cleaning Instructions Table

NOTICE

When docking or mooring your boat be aware of your surroundings i.e. trees with pollen, wet leaves, berries etc. These and other items can contain dyes that stain permanently. Utilize weather covers whenever possibly to protect vinyl from potential stains.

NOTICE

ALWAYS CLEAN STAINS IMMEDIATELY! DO NOT use 409 Cleaner™ or Armorall™ on vinyl. Do not use kerosine, gasoline or acetone as they will remove the protective marine topcoat.

NOTICE

All cleaning methods must be followed by a thorough rinse with water and drying.

Additional cleaning information is provided by the manufacturer and is included with this manual in the owner's packet.

Four Winns offers a variety of weather covers for protection of the boat and associated equipment. Continued exposure can damage the upholstery and seating. The seating can become thoroughly saturated with water if not adequately protected. Refer to Section O - Weather Covers for more information.

NOTICE

The appearance and longevity of the exterior upholstery will be affected by water saturation. Protect these items appropriately.

B. Exterior Carpets

The removable exterior grade carpeting may be periodically washed with mild laundry soaps or shampooed, dried and reinstalled. It is 100% UV stabilized Olefin™ polypropylene fiber with rubber backing. See Figure N-18.

NOTICE

Prior to using any mild laundry soaps or carpet shampoo, always conduct a colorfast test on a small inconspicuous portion of carpet before applying to entire carpet.

NOTICE

DO NOT dry carpeting in an automatic dryer.

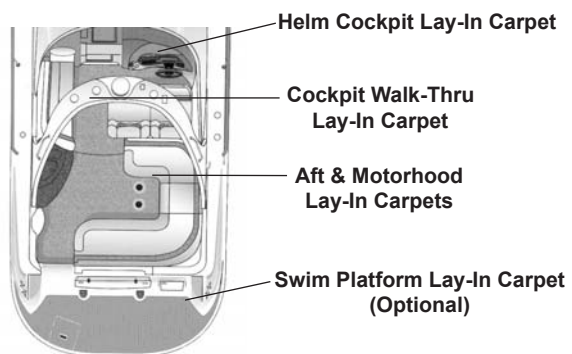

Figure N18: Cockpit Lay-in Carpet

C. Cleaning and Maintenance

The following information should be useful in helping you keep your carpet looking well maintained. Carpet made with Olefin™ fiber possesses built-in stain and soil release for easy, less costly maintenance. Regular vacuuming and occasional shampooing will help it stay attractive and serviceable.

D. Stain Removal Testing

Even the most stubborn stains can be removed from Olefin fiber following the procedures outlined. Stains were selected as being representative of spills commonly occurring on carpets. Stains were pressed into the carpet to simulate foot pressure following a spill. Stains were applied to a two-inch square section and allowed to penetrate. Removal was performed after two weeks. Carpets were tested for stain removal by an independent laboratory. Stain removal was effective for the all the stains selected. Results are shown in the table on the following page.

E. Stain Removal Procedures

Regular maintenance such as vacuuming, hosing or washing should be performed. Most stains and mildew are easily removed from carpet made with Olefin fiber using common household cleaners. Refer to Table I. Olefin™ fiber is so resistant to chemical attack that Clorox™ bleach may be used to clean up any mildew that may result from excessive wetness.

Code for stain removal procedure (See Table 1):

“A” Apply warm water and household detergent in minimal amounts to stained area. Sponge or scrape until stain is removed. Rinse with clean water.

“B” Apply warm water and household detergent. Work well into stained area then flush with warm water.

Most stains should be easily removed however, if the stain persists, the cleaning procedure should be repeated to insure stain removal. Remember, the sooner the stain removal process begins, the easier the stain will be to remove.

NOTICE

Do not use dry cleaning solvents on carpet or vinyl. Permanent damage to the fiber will result.

N - 5 REPLACEMENT UPHOLSTERY

Should upholstery become severely soiled, torn, or in some manner damaged, replacement upholstery cushions are available. Larger upholstery items have separate component parts for easier serviceability.

Depending upon the year and model of the boat, most upholstery parts can be obtained through your Four Winns servicing dealer within a short period of time.

STAIN	REMOVAL PROCEDURE
Automotive Grease	A
Automotive Oil (New or Used)	A
Bacon Grease	A
Berry Stain	A
Blood	A
Butter	A
Catsup or Mustard	A
Chewing Gum	A (Repeat)
Chlorine Bleach (5%)	A
Chocolate (Melted)	A
Clay	A
Coffee or Tea	A
Cola	A
Crayon	B
Dye	A
Egg	A
Feces	A
Fish Formula	A
Fruit Juice	A
Furniture Polish	A
Gravy	A
Ice Cream	A
Ink (Permanent Black)	B
Ink (Scripto, Ballpoint)	B
Iron Rust	A
Lipstick	B
Mayonnaise	A
Milk	A
Latex Paint	A
Oil Base Paint	B
Polish	B
Rust	A
Salad Dressing	A
Shaving Cream or Lotion	A
Tar	B
Urine	A
Vomit	A
Water Colors	A
Wax	B
Wine	A

Table I: Stain Removal

O - 1 GENERAL INFORMATION

Weather covers for the cockpit areas are available on all Four Winns® models. A bimini top and camper is standard on the 318 Vista® models. Four Winns® covers are designed and intended to provide protection of the cockpit seating areas.

Four Winns utilizes 100% acrylic-type material for most of its canvas. During the manufacturing of the weather covers, the smallest possible needle and highest quality UV stabilized, bonded polyester thread is used in the stitching.



Never use any form of open flame cooking device in any area fully enclosed or near weather covers. This material is flammable.

The weather cover is water repellent but not water proof. During a hard rain, you may notice a light mist permeating through a weather cover. This is normal. If the seams leak, they can be sprayed with Scotch-guard™ or similar type water repellent or a seam sealing compound can be applied. Keep objects from contacting the inside of the cover. Leakage may occur at point of contact.

Weather covers must be installed “snug” to prevent sags. The material relies on swelling to seal itself. If too taut or overly tight, the material will not seal and may tear.

NOTICE

Periodically check weather covers for accumulation of water. Damage to the bow assemblies may otherwise result. Make sure cover is snug to avoid puddling of water.

After use, the top canvas should be rolled up into the boot (supplied) and secured.

NOTICE

NEVER fold or store a wet weather cover. This can lead to mildew or shrinkage. Roll rather than fold the enclosure curtains. Sharp folds increase the chance of cracking the clear vinyl.

NOTICE

DO NOT use the weather covers for outdoor winter storage. The weight of the snow or heavy rain can cause severe damage to the material or top structure. Refer to O-7 - Winter Storage in this manual for more information.

Four Winns is utilizing snaps for the canvas. The snap sockets are a standard type. To unsnap, gently lift on the snap.

NOTICE

Remove snaps one at a time to prevent damage. DO NOT rip off or pull the weather cover as a whole; acrylic material will tear at snaps.

O - 2 GENERAL CANVAS INSTALLATION GUIDELINES

- 1) For safety and ease, it is recommended that two or more people are available to install or remove the canvas.
- 2) Ideally, canvas should be installed while the boat is in the slip or moored securely.
- 3) Be sure to observe all safety precautions to prevent the build-up of Carbon Monoxide - an invisible, odorless gas while the boat is running or underway.
- 4) Store canvas pieces flat, or if necessary, rolled; do not fold.
- 5) Bimini top, valances and/or camper top must be installed first; all other pieces attach to these pieces.
- 6) Partially zip zippers until all sides of a canvas piece are in position.
- 7) Support poles are adjustable; a button-release lets you slide the inner and outer tube to longer or shorter settings for a snug fit.
- 8) Unsnap canvas by lifting at the button to prevent damage; do not pull/yank.

- 9) Clean canvas with warm water, mild soap and a soft brush. For the clear Isinglass pieces use a soft, clean cloth. Be certain to rinse cloth often to remove any dirt collected in the cloth that could scratch the clear vinyl.
- 10) Make sure your bimini top and camper top are properly centered prior to installing the Isinglass enclosure.

O - 3 TRAILERING

High winds encountered during trailering your boat can severely damage most weather covers. If an extended trip at highway speeds is planned, the top and other weather covers should be booted or removed entirely. This will prevent damage and/or loss. See Figure O-1.

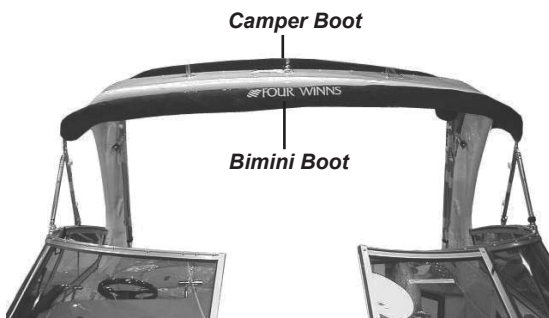

Figure O-1: Bimini & Camper Tops - Booted

NOTICE

DO NOT tow your boat at highway speeds with weather covers in place. High winds encountered during trailering your boat can severely damage most weather covers. Damage to weather covers incurred as a result of trailering your boat is not covered under warranty.

O - 4 BIMINI TOP

The bimini top is standard and provides cover/shade for the forward cockpit area. It is designed to be fastened to the radar arch with the use of a track. See Figure O-2.



Figure O-2: Bimini Top

A clear plastic visor is provided and once installed it connects the forward windshield and the bimini top. Side bimini curtains are also made of clear plastic for visibility and connect the side portion of the windshield to the bimini top. The helm area is protected from the elements once the bimini top, forward windshield connector and bimini side curtains are installed.

The bimini top is factory installed, therefore, minimal adjustment should be necessary.

To install the bimini top:

- 1) Attach the bimini frame using the ball and socket mounts. See Figure O-3.
- 2) Release the support pole and place in the forward mount; adjust upward to make it easier to zip canvas pieces.
- 3) Slide zippered valance into flexarail awning track on radar arch; center visually, zip bimini to valance, snap to the radar arch.
- 4) Place zipper pocket over forward frame.
- 5) Adjust the support pole to create tension on the bimini top.
- 6) Hint: If installing visor and side curtains, you may want to lower the adjustable support pole by 1-2 more notches.

For bimini top removal, reverse the previously described procedure.

NOTICE

Canvas should be snug. If too taut or extremely tight, canvas could tear or pull at seams.

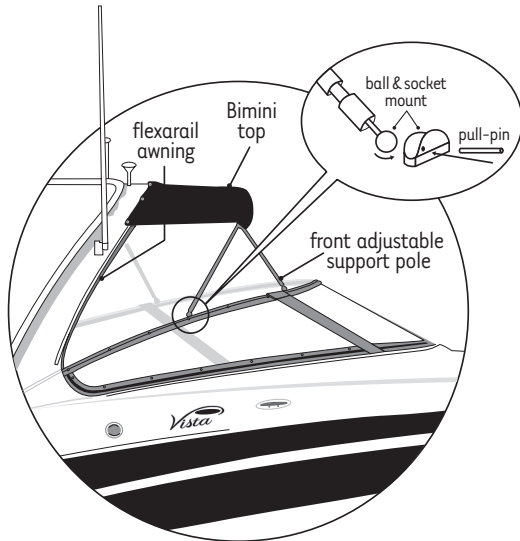

Figure O-3: Bimini Top Installation

Installing valances:

- 1) Valances - small areas of canvas curtain - are used to attach larger canvas pieces to the vessel. There are valances for the bimini side curtains, camper top and camper side curtains. See Figure O-4.
- 2) The bimini side curtain valance attaches with the velcro facing out.
- 3) The camper top valance attaches with the velcro facing in.
- 4) The camper side curtain attaches with the velcro facing out.

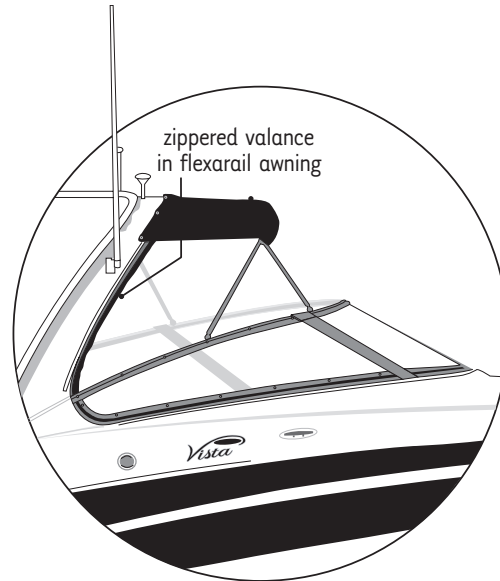

Figure O-4: Installing Valances

To install bimini side curtains & visor:

- 1) Install the bimini top and bimini side curtain valance (see previous installation instructions).
- 2) Locate the center, left and right windshield visors.
- 3) Attach the center visor piece to the bimini top, then each of the side visors - zipping each piece about 3" until all the parts are in position. See Figure O-5.
- 4) Finish zipping all the visor pieces.
- 5) Snap to the top of the windshield (from the outside if possible).
- 6) Locate the starboard and port side curtains.
- 7) Zip each partially in place in all directions, then complete the zipping.
- 8) Snap to the boat (from the outside if possible).
- 9) Secure and smooth all velcro closures.

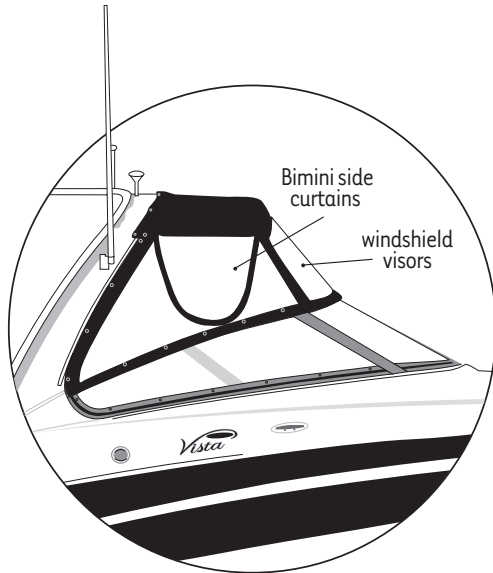

Figure O-5: Bimini Side Curtain & Visor Installation

NOTICE

Both the bimini and camper canvas have been designed and are intended to remain installed on the boat in the upright "stored" position. Four Winns does not recommend the bimini and/or camper assembly be removed from the boat unless absolutely necessary.

NOTICE

The bimini and camper canvas is designed as temporary shelter only. It should not be left up unattended for any length of time. Violent weather could result in expensive damage. Misuses is not covered under warranty.

NOTICE

Two people are recommended if removal or installation becomes necessary. Care must be exercised so the radar arch does not become damaged. Use a protective covering to prevent damage to arch if necessary.

NOTICE

In the event the canvas requires some maintenance or repair, remove the bimini camper canvas from the bow assembly. Unzip the bow sleeves, unsnap all snaps and straps, and remove the canvas.

O - 5 CAMPER

The camper is standard and provides cover/shade for the aft portion of the cockpit area. It too, is designed to be fastened to the radar arch with the use of a track. The camper aft curtain and camper side curtains can be installed to enclose the aft cockpit area. The camper and camper curtains used in conjunction with the bimini top, forward connector and bimini side curtains completely encloses the cockpit area when desired. See Figure O-6.

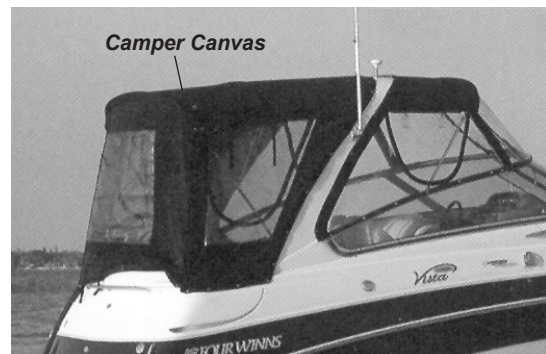

Figure O-6: Camper Canvas

To install the camper canvas:

- 1) With the long support poles in the back and the smaller, storage poles in the front (toward the radar arch), attach the camper top frame to the side mounts. See Figure O-7.
- 2) Tighten the bolt, first with your fingers and then with a wrench or other appropriate tool.
- 3) Release the storage poles and mount them using the ball and socket provided; secure with the pin.
- 4) Unzip canvas boot, if necessary.
- 5) Extend storage poles to reduce tension on the top.
- 6) Zip the camper top to the camper top valance.
- 7) Adjust the support poles to create tension on the top.
- 8) Center the canvas.
- 9) Secure and smooth all velcro closures.

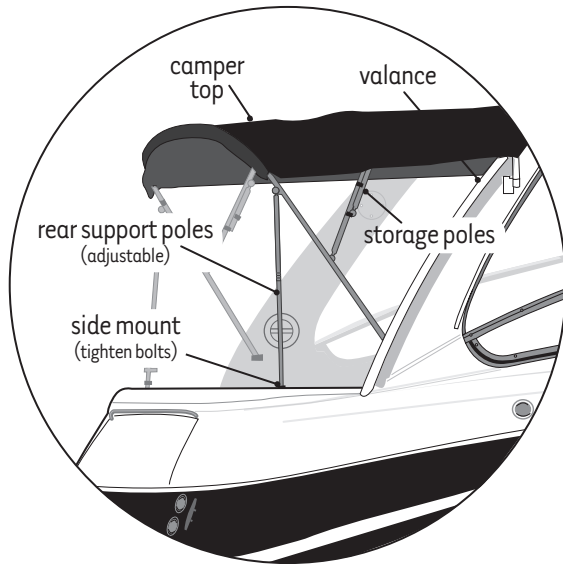

Figure O-7: Camper Canvas Installation

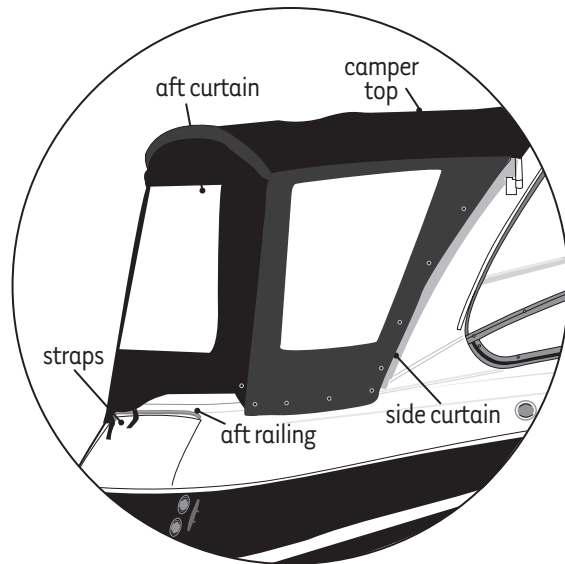

Figure O-8: Camper Side & Aft Curtain Installation

To install the camper side & aft curtain:

- 1) Follow directions for camper top installation (see previous installation instructions).
- 2) Starting at the top, start each zipper.
- 3) When all zippers have been started, complete zipping.
- 4) Snap the side curtains to the boat.
- 5) Smooth all velcro down.
- 6) Locate the aft curtain. See Figure O8.
- 7) Zip the aft curtain to the curtain top, starting at the center.
- 8) Secure with a strap to the aft railing or snap to transom.
- 9) Zip to port and starboard curtains.
- 10) Snap to boot.
- 11) Secure and smooth all velcro.

For camper removal, reverse the procedure described above.

This camper canvas is designed as temporary shelter only. It should not be left up unattended for any extended length of time. Violent weather could result in expensive damage. Misuse is not covered under warranty.

O - 6 COCKPIT COVER

The cockpit cover is optional and is used to cover the complete cockpit area and is intended as a short term storage cover. See Figure O9.



Figure O-9: Cockpit Cover

To install the cockpit canvas:

- 1) A cockpit cover is intended for short term storage only. Do not operate the vessel with the cockpit cover installed due to the potential for carbon monoxide gas build-up.
- 2) Find the center point on the canvas and attach it to the center point of the windshield.
- 3) Working outward equally in both directions, continue snapping the canvas in position.
- 4) When the canvas extends far enough, separate the velcro strips and install the cover around the bimini support poles. Reattach and smooth out the velcro. Slide the awning track into the flexarail. Attach to the inside of the radar arch.
- 5) Install support poles loosely - without a lot of tension at this point.
- 6) Attach straps to aft rail and pull to adjust. See Figure O-10.
- 7) Raise support poles to keep water from pooling on top of canvas.
- 8) Snap walk-thru area and visually check all your work.

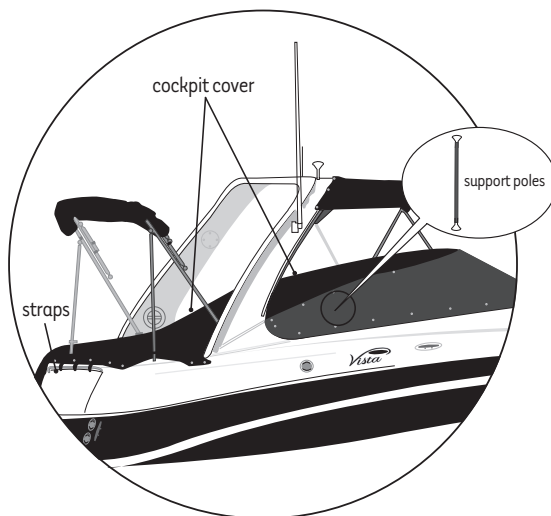

Figure O-10: Cockpit Cover Installation

O - 7 USE OF WEATHER COVERS AND CARBON MONOXIDE

When an engine is running, a natural vacuum may exist with the right wind and sea conditions to allow exhaust gases (which includes carbon monoxide) to seep into the boat. When canvas is utilized, this compounds the possibility of this occurring and inhibits natural ventilation. For more information, refer to Section B-2 - Carbon Monoxide in this manual.

The carbon monoxide in exhaust fumes can be hazardous. It is important for you and your passengers to be aware of the potential safety hazard created by exhaust fumes. Familiarize yourself with the symptoms of individuals overcome by carbon monoxide, and most importantly, ways you can protect yourself and your guests. See Figure O-11 - Carbon Monoxide Canvas Warning Label and Figure O-12 - Carbon Monoxide Warning Label.

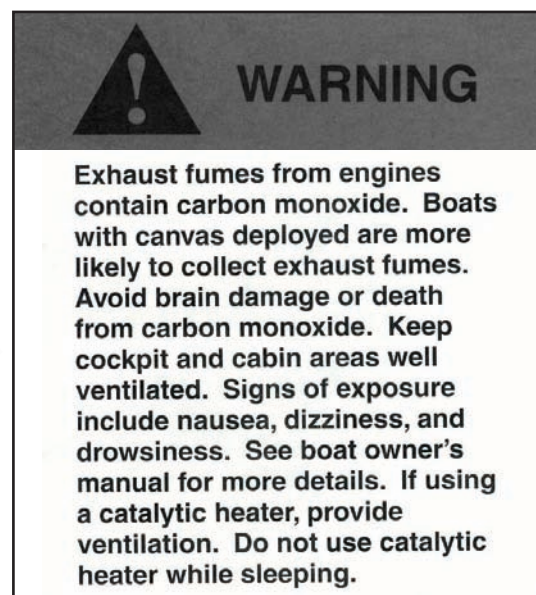

Figure O-11: Carbon Monoxide Canvas Warning Label

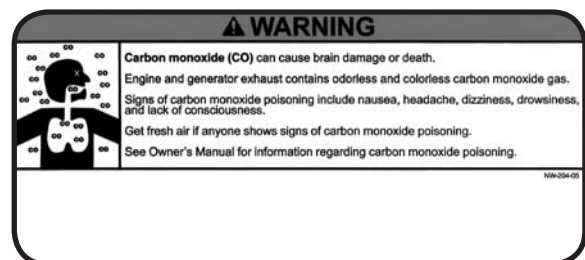



Figure O-12: Carbon Monoxide Warning Label

O - 8 WINTER STORAGE

The boat must be properly protected during winter dry dock storage. A winter storage cover is advisable. Many marine dealers offer shrinkwrap enclosures for outdoor storage. See a Four Winns dealer for information on the availability of winter storage covers or other alternatives for storage.

When storing outdoors, make sure the supporting framework keeps the weight of the snow and rain from accumulating on the storage cover. Proper ventilation must also be provided or dry rot and mildew will occur. See Section R - General Maintenance for additional winter storage information.

O - 9 MAINTENANCE

FOUR WINNS

RECOMMENDED CARE AND MAINTENANCE FOR YOUR FOLDING TOP AND ACCESSORIES

Your top and accessories should never be folded or stored wet. To clean top material, see manufacturers label for instructions. Occasionally your zippers and snap fasteners should be lubricated: White candle wax works well. The boat should never be trailered with the top erected. Side and aft curtains should be rolled with out creases in clear vinyl. Replacement parts are available through your dealer.

YOUR FOLDING TOP IS NOT WARRANTED AGAINST NEGLIGENCE OR MISUSE.

MODEL _____

DATE _____

WARNING: Do Not Operate Boat with Stern Curtain Closed. Cockpit must Be Open for Legal Fuel Compartment Ventilation.

Figure O-13: Canvas Care & Maintenance Tag

Moisture, dirt, chemicals from industrial fallout, heat, ultraviolet rays and in some cases, salt water are factors which affect the longevity of acrylic covers. See Figure O-13.

1. Moisture can cause shrinkage and mildew. Allow the cover to dry thoroughly before disassembling tops. Keep it clean and well ventilated to prevent mildew. Spraying the weather cover with Lysol Disinfectant™ or similar product will help prevent mildew.

2. Dirt creates a starting point for mildew when moisture is present. Clean the top with a sponge or soft scrub brush and mild detergent when the cover is installed. Make sure cover is snug to help prevent shrinkage.
3. Chemicals cause decay if allowed to accumulate for long periods of time. Keep the cover clean to prevent decay.
4. Heat can cause cracks in vinyl components and stiffening of fabric when enclosed in plastic or polyethylene. **DO NOT** store the weather cover in polyethylene under direct sunlight or high temperature situations.
5. Ultraviolet degradation may occur under prolonged exposure to direct sunlight. Store the top in the boot when not in use.
6. Salt water can corrode brass, aluminum, or stainless steel fittings and fasteners. Keep fittings clean, lubricated, and waxed to prevent corrosion.

Clear vinyl curtains and windows demand extra care to prevent scratching. Hose clean water onto vinyl to rinse off salt, dirt, or grime prior to using a soft, clean cloth. Dirt or grit in the cloth will scratch the vinyl window. Be sure to rinse cloth often.

NOTICE

DO NOT use hot water. DO NOT dry in an automatic dryer. DO NOT dry clean or steam press.

Leakage after cleaning may be the result of insufficient rinsing. Re-rinse. If leakage continues, apply a coat of silicone air drying water repellent, such as Scotchguard™. See your Four Winns dealer for additional information on weather covers.

P - 1 HULL DESIGN INFORMATION

Four Winns® boats are designed using the sound engineering and mathematical principles of hydrostatics, hydrodynamics, structure, and strength of materials. The materials utilized provide optimum strength at the lightest possible weight. The exact fiberglass laminate schedule and construction techniques of each part is determined in accordance with the strength and rigidity required.

P - 2 FIBERGLASS CONSTRUCTION

The fiberglass components of Four Winns® boats are of the finest quality materials, workmanship and construction techniques available. This ensures the structural integrity to provide years of boating enjoyment with minimal maintenance.

The construction of a Four Winns® hull begins with the application of gel coat to the mold. The gel coat is approximately 25 mils thick. A coat of resin and chopped fiberglass is then sprayed into the hull and carefully hand rolled until it is securely affixed to the gel coat.

A number of fiberglass layers and woven roving are applied to the above laminate. Each layer is hand laid and hand rolled. The keel and chine areas have fiberglass woven roving overlapped in these areas to provide additional strength. Most Vista® models utilize encapsulated end-grain balsa core or coremat laminates to achieve additional rigidity. Others utilize additional laminations of woven roving to maintain strength and rigidity.

The hull support stringers are located using special tools, and are fiberglassed and/or bonded into place. This ensures a strong, rigid hull, permanently formed into a solid assembly, free of distortions.

Fiberglass cockpit liners and seat base are constructed similar to the hull. Balsa core or coremat laminations are utilized when necessary.

In addition to a thorough visual inspection of each fiberglass component, samples are measured using special equipment, for fiberglass reinforcement to resin ratio, laminate configuration, weight and thickness. By these procedures Four Winns ensures proper composition.

P - 3 EQUIPMENT INSTALLATION

Many boats are used for specific purposes or under conditions which require the addition of special equipment to the hull or deck. Special care must be taken during the installation of any equipment to a fiberglass component. A polysulfide or butyl based sealant should be used to seal installations below the water line. Silicone “marine” seal or similar bedding compound should be used elsewhere.

NOTICE

DO NOT install any item onto or through the hull without adequately sealing the hull area penetrated by the installed item or related fasteners. Improper installations could cause leakage or allow water absorption and thus cause serious hull damage.

Always pre-drill fastening holes with a proper size bit. Pre-drilling will help prevent the fiberglass from splintering and thus causing unsightly damage. Also, countersink holes to prevent the gel coat from chipping.

Any equipment which will be subjected to cyclic loading or significant force should be through-bolted to a fiberglass component. A butt block or backing plate should be used to strengthen any area onto which an item will be mounted.

P - 4 FIBERGLASS CARE & MAINTENANCE

Fiberglass is affected by weathering processes and requires maintenance on a periodic basis to help maintain the beauty and shine. The effects upon the gel coat will be dependent upon boating conditions, storage, type of use, and the care given to the boat during the boating season.

Four Winns utilizes fade-fighting gel coat in the exterior finish. It is specially formulated to resist fading and yellowing, and retain more of its original gloss than better grade gel coats. However, it is still important to maintain the gel coat to protect the finish.

A. General Maintenance

For fresh water use, the boat should be washed once or twice a month. When using in a salt water environment, considerable more care will be necessary. Be careful when selecting a cleaning agent. Hand dish

washing detergents are usually gentle and are recommended for cleaning gel coat. Cleaning products such as Ivory™ or Dawn™ hand dish washing liquid can be safely used. Always read the label before using any product.

NOTICE

DO NOT use acetone, paint thinner, solvents, or strong alkaline based detergents, nor cleaners with a “gritty” and abrasive texture. Avoid products which contain sodium phosphate. Common examples of these types of household cleaning agents are: Tide™, Oxydol™, Janitor-in-a-Drum™, Fantastik™, Clorox™, etc. Always read the label before using an agent.

There are several products available which are specifically designed to clean fiberglass exterior finishes. Many companies like Johnson & Johnson®, Turtle Wax®, etc. manufacture cleaning fluids mild enough to clean without stripping the wax.

NOTICE

Treading on a soiled fiberglass surface can severely scratch and mar the finish. Keep the fiberglass as clean as possible.

When cleaning skid-resistant areas, DO NOT attempt to use a wire brush or sandpaper because this will remove the skid-resistant gel.

Apply wax once or twice a year to maintain gel coat lustre. Read the label before using any product. Make sure product is formulated for gel coat surfaces. Also, consult a Four Winns dealer for their recommendations.

NOTICE

Do not use carnuba based waxes. This type of wax yellows over time and makes the fiberglass appear yellow.

CAUTION

Waxing decks, cockpit floors or other walking areas is not recommended. Waxing will produce a very slippery surface, especially when wet. Wax may also buildup in the skid-resistant surfaces. Be sure all persons wear deck shoes while aboard the boat. Footing will be improved and feet will be protected from accidental cuts and bruises.

A darkening or discoloration of the skid-resistant surfaces can sometimes occur as a result of wax buildup. Exposure to the sun and elements can turn the wax darker, or occasionally can cause it to become flaky or powdery. To remove, use fine rubbing compound and a low rpm buffer (1200 to 2000 rpm). Apply light pressure and keep the buffer moving at all times to prevent heat build-up. Read the directions before using any equipment.

B. Weathering Effects on Gel Coat

Weathering occurs from direct sunlight, water, chemicals, and dust. Some of the terms below describe the changes that can occur to the gel coat surface.

Chalking is a result of the gel coat's top surface being broken down into an extremely fine powder. When this happens, the color whitens. The chalk is present on the surface only.

Fading is the uniform change in color. This happens when the actual pigments have changed color, especially from excessive chalking, or when the gel coat has either been stained or bleached by something.

Yellowing is gel coat which has a yellow cast and streaking usually deals with a stain or contact with another surface.

Gloss refers to the shine of the surface. This can change from sanding action, chalk, residues, or exposure.

Blistering refers to a condition in which the unprotected gel coat surface below the waterline has absorbed water and formed bubbles. See Section P-5 for additional information.

Follow the instructions on the following page for boats that have weathered and chalked.

1. Wash.
2. Wax. If this does not work, then use a fine rubbing compound. If this does not work use 400 or 600 wet or dry sandpaper, followed by fine rubbing compound and wax.

When using wax or fine rubbing compounds, make sure to read the label and follow the directions. Some helpful tips are listed below.

1. Avoid working in direct sunlight. This dries out the wax or compound, and can stain the surface.
2. Use clean pads or cloths to apply a thin coating of wax or rubbing compound to a small area such as three feet by three feet. Remove any excess, and then rub the area with a buffing pad, or power buffer. Apply pressure only as necessary to restore the surface finish. Applying too much pressure or buffing in one place too long can permanently damage the surface.
3. After applying compound, always follow with waxing.

NOTICE

If using a power buffer, use a low RPM buffer with light pressure. Keep the pad wet and the buffer moving at all times to prevent heat buildup.

NOTICE

To prevent gouges, uneven areas, or other damage from occurring, DO NOT use a power or belt sander when sanding. For best results, block sand the gel coat.

C. Stains

Stains can appear anywhere on the exterior of the boat and may be a result of contact with tar, plant sap, leaves, rust from metal fittings, and other materials. Surface stains may be removed with hand dish washing soap, mild cleansers, or some household detergents. DO NOT use chlorine or ammonia products. These products can affect the color of gel coat. Commercial car washes use strong cleaners and should be avoided.

To remove stains, refer to the procedures below.

1. Wash area with hand dish washing soap.
2. Begin with a small area such as three feet by three feet and apply a mild cleanser.
3. Rinse with clean water.
4. Follow with compound and waxing as outlined in procedure above.

If the stain is not removed by the hand dish washing soap or mild cleanser, then the next procedure is to use either denatured or rubbing alcohol. If this does not work, consult your Four Winns dealer for professional assistance.

NOTICE

DO NOT use acetone, ketone, or other solvents to remove stains. These chemicals are flammable and may damage the gel coat.

P - 5 FIBERGLASS REPAIRS

Fiberglass is one of the most durable, strong, and forgiving construction materials afloat. It is resilient and normal repairs can be made without affecting the strength or structural integrity of the boat.

WARNING

Striking docks, other boats, or submerged objects could create a very hazardous situation or severely damage the fiberglass. In the event an object is struck below or near the waterline, proceed directly and cautiously to the nearest service facility and remove the boat from the water. Closely inspect the hull for damage. If the outer fiberglass laminate was penetrated, repairs must be made prior to relaunch.

Occasionally, blisters, crazing, scratches or damage to fiberglass can occur. Repairs may be necessary to correct the problem.

A. Scratches

Scratches occur during normal use. The following is a step by step procedure to repair scratches.

1. Clean area with soap and water.
2. Apply a fine rubbing compound and buff.
3. Wax.

If this does not work, clean the area and sand lightly with 400 to 600 wet or dry sandpaper and follow with rubbing compound and wax.

B. Gouges & Cracks

Stress cracks and crazing are the appearance of hairline cracks in the gel coat surface. When present, these problems usually occur in the gel coat finish or the outer “skin coat” fiberglass laminate. The appearance of these cracks does not pose a threat to the structural integrity of the boat. In most cases, they are cosmetic and can be treated.

Cosmetic surface damage can be repaired as follows:

1. Sand the surrounding area with medium or fine grit sandpaper. Clean all marine growth, dirt, antifouling paint, etc. from the immediate area. DO NOT excessively scratch or gouge the surrounding area.
2. Use a hard, pointed tool to open the gel crack. Take care not to damage the surrounding gel coat.
3. Sand the crack or gouge so the edges are smooth and will allow proper “feathering” of the area.
4. Clean the area thoroughly. Make sure the area is dry before proceeding.

NOTICE

Be sure the structure and the ambient temperature are above 60 degrees F (15 degrees C) and the relative humidity below 70% immediately before, during, and after the repair.

5. If the nick or gouge is deep and penetrates through the gel coat, fill the area with fiberglass patching paste. Follow the directions on the can when mixing the paste with the catalyst.
6. After the gouge is filled and has dried, sand the patched area. Begin by using medium-fine grade sandpaper. Progressively use finer grade sandpaper until the surface is very smooth. If necessary, add filler and then sand the surface again.
7. Apply two or three light coats of matching fiberglass gel coat to the repaired area. Enough gel coat should be used so that the entire area is

covered. The gel coat must be catalyzed using up to 2% MEK Peroxide which can be purchased at a supplier handling fiberglass reinforced products. Contact your Four Winns dealer for assistance.

8. After ample drying time, sand the area using very fine wet/dry sandpaper. If the appearance of the area is still not satisfactory, repeat steps 2 through 4 as necessary.
9. If above the waterline, polish the area using a fiberglass rubbing compound and then wax. If the repaired area is below the waterline, the area should be primed and painted in accordance with the antifouling paint manufacturer’s instructions.

Gel coat, like paint, will change colors with time and exposure to sunlight (ultraviolet). For this reason, “matching” gel coat obtained from Four Winns may not match the gel color of a boat that has been exposed. However, this is the closest match commercially available. A fiberglass technician can tint the gel to be used in the repair to provide a closer color match.

More severe fiberglass damage, especially when structural, requires the expertise of an experienced fiberglass repair technician. See your Four Winns dealer for assistance.

NOTICE

Improper repair techniques can lead to further fiberglass component damage.

C. Osmotic Blistering

Osmotic blistering or “boat pox” is an unfortunate but not uncommon occurrence in fiberglass boats. Fiberglass is water retardant, not waterproof. When a boat is left in the water for a period of time, the fiberglass will absorb water. It is a natural process that can not be eliminated in production methods or material selection and usage. However, there are ways to control and possibly prevent blisters (see Section P-6). If you do encounter blisters, be assured that the blisters are merely cosmetic. They do not indicate a defect in the boat structure or lamination. Four Winns, along with most boat manufacturers, regard gel blisters as a standard maintenance item.

The repair procedure for gel coat blisters is similar to the procedures outlined in the previous section on cracks and gouges. There is an exception however,

in that the hull must dry out for several days or possibly weeks before repairs can proceed.

To determine if the hull has dried sufficiently, tape one square foot of household plastic wrap securely to the hull bottom. Make sure all edges are sealed and let it stand for twenty-four hours. If condensation has accumulated under the plastic, the hull is still “wet” and must be allowed to dry longer before repairing.

When the repair is completed, an application of an epoxy barrier coat should be considered. This will help prevent the possibility of reoccurrence of blisters. Your Four Winns dealer or local ship store will have information on barrier coat products.

P - 6 ANTIFOULING PAINT

Four Winns recommends antifouling or bottom paint for boats which will be kept in the water for extended periods of time. Antifouling paint reacts with water to retard the growth of algae, barnacles and other marine growth on the hull. In addition to marine growth, it offers protection against excessive water pollution.

Antifouling paint begins reaction upon contact with water. After a season’s use or sooner under certain conditions, the antifouling paint may appear to be dissolving. This is due to the paint’s chemical emission that in turn retards marine growth. When this occurs, refinishing is in order. For bottom paint line location, refer to the Figure P-2 at the end of this section.

Four Winns recommends reapplication of the antifouling paint seasonally. The effectiveness of the paint will be drastically reduced if used longer. Though Four Winns has found the antifouling paints used to provide good marine growth protection in most water, other paints may be more effective in certain water conditions. See a Four Winns dealer for recommendations on antifouling paint use in your area.

NOTICE

During surface preparation, the hull should be sanded only enough to remove any foreign matter, and loose paint. DO NOT sand deeply into the gel coat, fiberglass cosmetic problems could later result. After sanding, the surface should be wiped with a rag treated with a cleaner recommended by the antifouling paint manufacturer. The surface must be clean and slightly rough to ensure paint adhesion.

Prior to application of the antifouling paint, the boat owner may consider coating the hull bottom with an epoxy coating. Four Winns recommends this procedure as a preventive and effective means of controlling osmotic blistering. Most major antifouling paint manufacturers also supply a line of epoxy undercoatings. Consult your Four Winns dealer for recommendations on epoxy undercoatings.

P - 7 HULL SUPPORT

Proper support of the hull while it is out of the water is imperative. Due to the design complexities, Four Winns does not recommend trailers or storage cradles be homemade. The boat is a valuable piece of equipment. DO NOT risk permanent damage to the hull structure in an attempt to save the cost of an adequate support. Improper support can lead to serious and permanent hull deformation.

CAUTION

While lifting the boat, ensure slings are in the proper locations as indicated by the sling location labels. Failure to do so may result in permanent hull structure damage and will invalidate the hull structure warranty.

NOTICE

When attempting to raise the hull, never allow one end of the boat to rise first, while letting the opposite rest momentarily on the underwater gear. Serious damage to these components could result. DO NOT place lifting straps on underwater gear. Be sure the strap is against the hull surface only and are in proper location as indicated by the sling label location.

A trailer, or storage cradle designed for a larger or smaller boat will not provide proper support for the hull. This could lead to hull deformation and thus serious performance deficiencies.

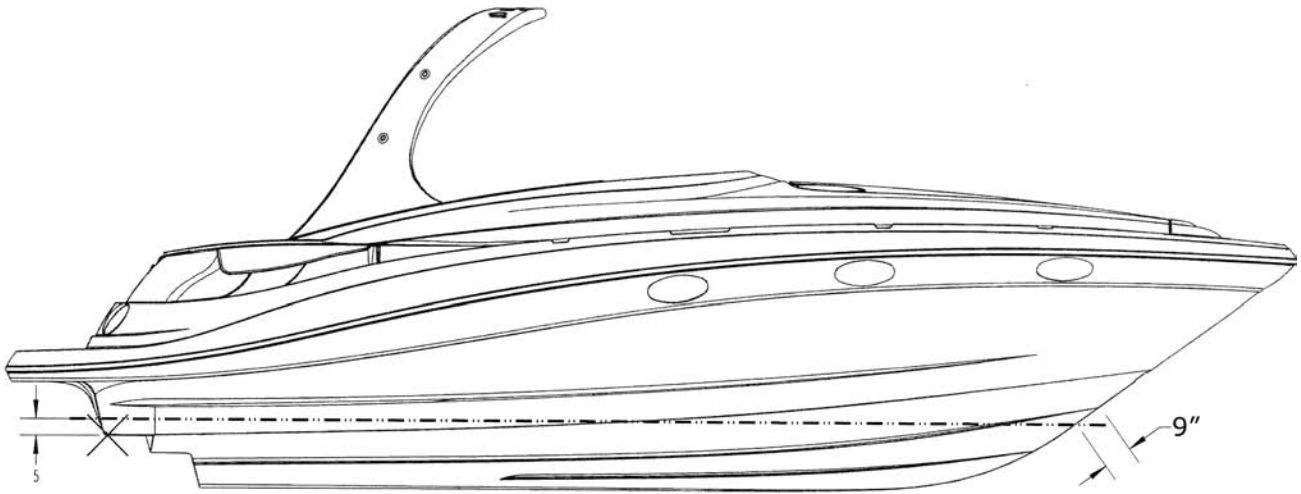

Figure P-2: 318 Vista® Bottom Paint Line Location



Q - 1 HIGH-PRESSURE LAMINATE CARE

Much of the 318 Vista® interior components such as the shelving, closets, closet door and drawer fronts consist of a high pressure laminate material. The finish is that of a synthetic cherry and can be cleaned with hand dish washing soap and water or other cleaning solutions such as Fantastik™. Always read the label before using any product.

NOTICE

DO NOT use abrasive cleaners or solvents on laminate. DO NOT use Soft Scrub soap or similar cleaning products; they will scratch the surface and remove the shine.

Q - 2 CHERRY

Four Winns uses cherry wood trim throughout the 318 Vista® model interior. The wood is prepared with a light stain followed by a polyurethane finish. To clean, a damp cloth will usually suffice. Care should be similar for cherry as it is for fine, household furniture. See Figure Q-1.



Figure Q-1: Cherry Trim

Q - 3 STAR BOARD

Star board is a high density polyethylene (plastic) and is very durable and fade resistant. Star board requires little maintenance, and is being used in place of wood in many areas of the boat.

To clean star board, use a solvent-free, nonabrasive cleaner such as hand dish washing soap or Fantastik™. Read the label before using any cleaning product.

NOTICE

Star board will stain when exposed to certain oils or chemicals. Always wipe up any spills immediately.

Q - 4 LAMINATED FIBERGLASS

Certain components such as cockpit tables, seat bases, storage tubs, storage lids/doors, ect. may consist of a laminated fiberglass material. These components may be cleaned with mild dishwashing soap and water. After washing, a light coat of wax may be applied as necessary. Always read the label before using any product.

NOTICE

DO NOT use abrasive cleaners or solvents on cockpit table. DO NOT use Soft Scrub™ soap or similar cleaning products; they will scratch the surface and remove the shine.

Q - 5 VINYL COVERED MEDIUM DENSITY FIBERBOARD (MDF)

The 318 Vista® cockpit table may consist of a vinyl covered medium density fiberboard. The use of MDF material with this vinyl exterior creates a light weight yet strong table for use in the cockpit area. It can be cleaned with mild dishwashing soap and water. Always read the label before using any product. See Figure Q-2.



Figure Q-2: Cockpit Table

NOTICE

DO NOT use abrasive cleaners or solvents on cockpit table. DO NOT use Soft Scrub™ soap or similar cleaning products; they will scratch the surface and remove the shine.

NOTICE

DO NOT use cockpit table as a cutting board. The knife will leave gouges/marks in the surface of the table.



Figure Q-4: Galley Countertop

Q - 6 WOODGRAIN ENHANCEMENTS

Woodgrain enhancements are available on the 318 Vista® models. They consist of a finished synthetic mahogany. This burlwood may be found in the instrument trim tabs panel, steering wheel and ignition switch panels of the 318 Vista® series. To clean, a damp, clean cloth will usually suffice. See Figure Q-3.



Figure Q3: Burlwood Helm

Q - 7 FIBERGLASS COUNTERTOP WITH SOLID SURFACE INLAY

The countertop for 318 cabin galley is made of laminated fiberglass with a solid surface inlay. The exterior of the countertop is gel coat. This makes for an extremely strong yet lightweight countertop. It can be cleaned with mild hand dish washing soap and water or other cleaning solutions such as Fantastik™. Always read the label before using any product. Please read the notices below. See Figure Q-4.

NOTICE

DO NOT use abrasive cleaners or solvents on countertop. DO NOT use Soft Scrub™ soap or similar cleaning products; they will scratch the surface and remove the shine.

NOTICE

DO NOT set hot pans or dishes directly on the countertop. The countertop may become burnt and/or discolored. Use of a hot pad will prevent any discoloration from occurring.

NOTICE

DO NOT use countertop as a cutting board. The knife will leave gouges/marks in the surface of the countertop. A cutting board that fits over the sink is provided.

Q - 8 SOLID SURFACE MATERIAL

Solid surface material is utilized in the refreshment center countertop and head sink countertop of the 318 Vista® models. A solid surface insert may also be found in the galley countertop as well. The solid surface gives these countertops a rich look and makes for an extremely strong yet lightweight top. It can be cleaned with hand dish washing soap and water, or other cleaning solutions such as Fantastik™. Always read the label before using any product. See Figures Q-5 and Q-6.

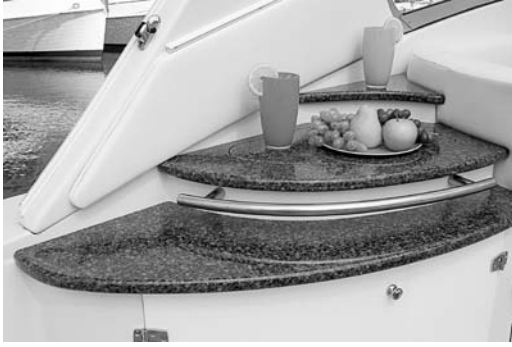

Figure Q-5: Refreshment Center



Figure Q-6: Head Sink w/ Hard Surface Countertop

Q - 9 ACRYLIC PLASTIC - (PLEXIGLASS)

Acrylic plastic is utilized in the companionway doors, transom doors, deck hatches, portlight windows, sliding storage doors, electrical panel doors, cabinets and cabin windows. See Figure Q-7.



Figure Q-7: Companionway Door

To clean acrylic plastic:

- 1) Rinse with plenty of water to wash off as much dirt as possible.
- 2) Using your bare hand, along with plenty of water, feel and remove any dried on dirt or mud. Do not use fingernails to scrape as this could scratch the plexiglass.
- 3) Wash using a soft, grit free cloth or sponge and mild, nonabrasive soap or detergent.
- 4) Blot dry using a clean, damp chamois.

NOTICE

Never use a dry cloth, duster, glass cleaning solutions or citrus cleaner on acrylic plastic.

NOTICE

Do not use solvents such as acetone, silicone spray, benzine, carbon tetrachloride, fire extinguisher fluid, dry cleaning fluid, lacquer thinner or ammonia. These solutions attack the acrylic surface.

You can use fine automotive acrylic rubbing and polishing compounds to remove fine scratches on acrylic.

Q - 10 FLEXITEEK

An available option is a flexiteek cockpit and/or swim platform. Flexiteek is made up of a composite PVC based material with a surprising similarity and look to that of real teak. Flexiteek can be cleaned with mild dishwashing detergent. Please contact your Four Winns dealer for further details.

R - 1 WINTERIZATION**A. Prior to Lifting for Winter Lay-up**

1. Pump out the head (dockside discharge), and be sure the holding tank is empty. Flush the head holding tank with soap, water and a deodorizer (e.g., Lysol Liquid™). Add more water if necessary. Have the cleaning solution pumped out.
2. Have the fuel tank either full or completely empty. See the Engine Owner's manual for recommendations. Also, check with the dry dock operators for recommendations. If winter storing with a full fuel tank, gasoline winterizer such as Sta-bil® fuel conditioner, will reduce varnishing, condensation, etc.

NOTICE

If the fuel has been treated with winterizer, run engines for ten minutes to make sure the treated fuel is present in all lines and parts of the engines.

3. Drain water from the fresh water system and the hot water heater.
4. Winterize the engine and drive systems as recommended in the engine owner's manual (applies to both gas and diesel systems). Portions of this winterization procedure may require that the boat be lifted. Winterization of engine and boat systems should be performed by qualified service personnel.
5. Lift the boat only at the designated "sling" labels. See Section P-7 - Hull Support and the Preface page 6 of this manual for additional details.

B. After Lifting

1. Remove the drain plug.
2. Thoroughly wash the fiberglass exterior, especially the hull bottom. Remove as much marine growth as possible. Wax lightly.
3. Lower boat onto cradle properly or place boat on trailer. Be sure boat is adequately supported. The boat should be raised slightly under the forward supports or trailer tongue to improve drainage to the transom drain.

4. Be sure all the water is completely drained from the fresh water system. Disconnect all hoses, check valves, etc. and blow all the water from the system using very low air pressure. The use of nontoxic, fresh water system antifreeze is recommended as an alternative to disassembling the water system. Refer to Section J-7 - System Maintenance in this manual for information on winterizing the water system.
5. Winterize the head as recommended by the head manufacturer. If the boat is equipped with a holding tank, mix some antifreeze solution and pour it into the head. Transfer some of the antifreeze to the holding tank by flushing the head. Also, refer to Section J-7 - System Maintenance for additional information.
6. Drain or winterize the air conditioning and generator system. Follow the appropriate manufacturer's directions. Be sure all water intake filters are drained thoroughly.
7. Ensure that all water is removed from the sump pump, bilge pump and bilge pump lines. Dry the hull bilge, and self-bailing cockpit drain troughs. Water freezing in these areas could cause damage. See Section K-3 - Hull Drainage Systems.
8. Remove the batteries and store in a cool place. Clean the batteries using clear, clean water. Be sure the battery has sufficient water and clean terminals. Keep the batteries charged throughout the storage period. DO NOT store the batteries on a concrete floor or other damp or conductive surface.
9. Drain the alcohol out of the stove (if applicable) and store alcohol in a cool, dry place away from heat or spark.
10. Clean the boat interior thoroughly. Vacuum carpets, and dry clean drapes and upholstery jackets as necessary.
11. Wash exterior fiberglass components, wax lightly.
12. Clean exterior upholstery with hand dish washing soap and water, rinse, and dry thoroughly.
13. Remove all oxidation from exterior hardware and apply a light film of moisture - displacing lubricant.

C. Prior to Winter Storage

1. Remove as many cushions as possible. Remove storage lids or hatches. Open as many locker doors, as possible. Open the refrigerator door. Leave these areas open to improve ventilation.
2. Spray the weather covers and the boat upholstery with Lysol Spray Disinfectant™. Enclosed areas such as the refrigerator, shower basin, storage locker areas, etc. should also be sprayed with Lysol Disinfectant™.
3. Place small dishes of rodent poison such as D-Con™ in a number of areas around the boat. Be sure dishes are placed near the head and the engines, as rodents will destroy upholstery, water intake and discharge hoses.
4. If the boat will be in outside storage, properly support a storage cover and secure it over the boat. DO NOT secure the cover tightly to the boat. This does not allow adequate ventilation and can lead to dry rot. DO NOT store the boat in a damp storage enclosure. Excessive dampness can cause electrical problems, corrosion, and dry rot.

 **WARNING**

Placing an electric or fuel burning heating unit in the bilge of the boat during cold weather could cause fire or explosion and is not recommended.

5. DO NOT use the bimini top or camper top as a winter storage cover. The life of these covers may be significantly shortened if exposed to harsh weather elements for long periods.

NOTICE

Boats stored outside in areas with heavy snow accumulation are more susceptible to damage, and should be inspected regularly during the winter months.

R - 2 ENGINE FLUSH OUT

The optional engine flush out (if applicable) should be used to clean the engine of unwanted salt, mud, sludge, etc. which may have accumulated in the engine cooling system. Before winterizing the engine, flush out the system for about ten minutes.

A. Volvo Penta® Engine Flush Out (Four Winns Installation)

 **CAUTION**

Make sure that no section of flush hoses is in contact with moving or hot engine parts or abrasive surfaces such as screw threads, sharp edges, etc., which could damage the hoses. Damage to the hoses could cause leaks and possible flooding of the engine compartment. Periodically check hoses for abrasions.

NOTICE

The Four Winns installed flush out kit for Volvo Penta® engines is identified by a transom deck mounted coupler & cap. This type of flush out may be used with the boat in or out of the water and the engine OFF.

*Volvo Penta's engine flush out is directly attached to the engine itself and is identified by a blue cap. If the engine comes with this type of flush out kit installed from Volvo Penta, **follow the procedure included in the engine operator's manual only.***

To flush out the engine with Four Winns installed flush out kit, follow the instructions below:

1. **Do not run engine during flushing procedure.**
2. Remove cap from coupling and attach water supply hose.
3. Turn water on and allow water to flush the engine and exhaust manifold for about ten minutes.
4. Turn water off. Disconnect hose; replace and tighten cap securely.

 **CAUTION**

Reinstall cap onto coupler after flushing for both types of flush outs. The cap must be secured after flushing of engine to prevent air from entering the system and resulting in possible engine damage.

B. MerCruiser® Engine Flush Out Option

 **CAUTION**

MerCruiser® engine flush out procedures if not followed in accordance to their specific instructions can result in costly engine damage. Follow MerCruiser's specific instructions for flush-out procedures located in the Engine operator's manual. Consult engine manufacturer's authorized service center for additional assistance should further questions arise.

 **CAUTION**

Make sure that no section of flush hoses is in contact with moving or hot engine parts or abrasive surfaces such as screw threads, sharp edges, etc., which could damage the hoses. Damage to the hoses could cause leaks and possible flooding of the engine compartment. Periodically check hoses for abrasions.

NOTICE

The Four Winns installed flush out kit for MerCruiser® engines may be used with the boat in or out of the water and the engine ON. See MerCruiser's engine operator's manual for the specific engine flushout procedure.

 **WARNING**

For out of water flushing, avoid possible injury by removing the propeller and ensure that no people or animals are in the area of the drive unit while flushing. Contact with moving drive components and the propeller can cause personal injury or death.

To flush out the MerCruiser® engine follow the guidelines below as well as the specific procedure outlined in MerCruiser's engine operator's manual:

1. Remove cap from coupling and attach water supply hose.
2. Turn on water supply - See Engine owner's manual.
3. **The engine must be running at idle during flushing procedure.**
4. Allow water to flush the engine and exhaust manifold for about ten minutes.
5. Turn engine OFF and turn water off. Disconnect hose; replace and tighten cap securely.

 **CAUTION**

Reinstall cap onto coupler after flushing. The cap must be secured after flushing of engine to prevent air from entering the system and resulting in possible engine damage.

R - 3 GENERAL MAINTENANCE SCHEDULE

SERVICE	AT LAUNCH AND FIRST OPERATION*	25 HOUR CHECK EACH SEASON*	BI-SEASONALLY OR EVERY 6 MONTHS OR EVERY 100 HOURS*	SEASONALLY OR EVERY 12 MONTHS OR EVERY 200 HOURS*
Engine and Instrumentation	Refer to Section E			
Engine Maintenance	As Recommended by the Manufacturer			
Inspect Exhaust System Hoses and Connections				
Inspect Cooling System Hoses, Connections and Impellers				
Check Propellers				
Check All Thru-Hull Fittings				
Gauge Cleaning				
Controls Systems	Refer to Section F			
Throttle and Shift Adjustment				
Neutral Safety Switch Test				
Cable and Control Lubrication				
Steering Systems	Refer to Section G			
Linkage and Connection Inspection				
Stem Drive Torque Tab Adjustment				
Power Steering Service	As Recommended by the Manufacturer			
Steering Adjustments				
Steering System Lubrication				
Electrical Systems	Refer to Section H			
Inspect Battery Connections				
Check Battery Water				
Battery Cable Inspection				
12 Volt Electrical Equipment Operation				
12 Volt Wiring and Connection Inspection				
120 Volt Electrical Equipment Operation				
120 Volt Wiring Inspection				
120 Volt System Continuity Test				
Shore Power Cord and Adapter Inspection				
Polarity Light Operation				
Receptacle and Connection Inspection				
Generator Maintenance (If Applicable)	As Recommended by the Manufacturer			
Inspect Generator Water Intake and Exhaust				

* Or as Required

SERVICE	AT LAUNCH AND FIRST OPERATION*	25 HOUR CHECK EACH SEASON*	BI-SEASONALLY OR EVERY 6 MONTHS OR EVERY 100 HOURS*	SEASONALLY OR EVERY 12 MONTHS OR EVERY 200 HOURS*
Fuel System	Refer to Section I			
Inspect for Leaks				
Fuel Sender Inspection				
Fuel Filter Inspection				
Fuel Tank Inspection				
Water Systems	Refer to Section J			
Inspect All Water Systems				
Fresh, Grey & Holding Tank Inspections				
Drain & Flush Fresh Water System				
Drain & Flush Waste Water System				
Drain & Flush Grey Water System				
Ventilation and Drainage	Refer to Section K			
Engine Blower Operation	Before Every Use			
Head Blower Operation				
Blower Vent System Cleaning				
Bilge Pump Operation and Cleaning	Before Every Use			
Check Transom Drain Plug				
Deck Hatch, Porthole & Aft Window Cabin Operation				
Interior Equipment	Refer to Section L			
Air Conditioner	As Recommended by the Manufacturer			
Head Maintenance	As Recommended by the Manufacturer			
Thru-Hull Fitting Inspection				
Icemaker and Refrigerator Cleaning				
Clean Cooler	As Required			
Inspect Stove Fuel System (If Applicable)				
Stove Maintenance	As Recommended by the Manufacturer			
Exterior Equipment	Refer to Section M			
Check PFD's for Serviceability and Correct Number	As Required			
Check Charge of Fire Extinguishers	As Required			
Clean Spotlight				
Check Compass for Magnetic Deviation				
Windlass Maintenance (If Applicable)	As Recommended by the Manufacturer			
Check Trim Tab Fluid Level				
Check Trim Tab System for Leakage				

* Or as Required

S - 1 LAUNCH AND CRUISE CHECKLIST

- Get a current weather report. If the weather will not be favorable, postpone your trip.
- If your boat has been out of the water, check to see that all bilge water has drained out.
- Install hull drain plugs.
- Inspect the hull and propeller for damage. Excessive dirt or marine growth will effect your boat's performance and fuel efficiency.
- Check the electrical system and navigation lights.
- If your boat has been in the water, run the bilge pump until the flow of water stops.
- Check that all required safety equipment is on board and in good working condition. Examples include personal flotation devices (PFDs), horn, fire extinguisher, visual distress signals, etc. Take along extra drinking water.
- Check that other important equipment is on board. Examples include mooring lines, anchor and line, tool kit, first aid kit, etc.
- Open engine compartment. Inspect for fuel odors and visible leaks in the fuel, oil, coolant, exhaust and power steering systems.
- Visually inspect engine for cracked hose, defective belts, or other signs of engine problems. Check engine oil and battery water levels. Check power steering fluid level. Check battery electrolyte range.
- Check fuel level. Fuel tanks should be filled to slightly less than capacity. Allow for fuel expansion.
- Check that all engine drains are closed (stern drives).
- Make sure navigation charts and equipment are on board.
- Check operation of steering system, navigation lights, and operation of horn.
- Make sure passengers and crew know what to do in case of an emergency and how to operate safety equipment.
- Make sure all required documents are on board.
- File a float plan with a responsible party ashore.
- Keep an eye on the weather. Be aware of possible changing conditions by monitoring local weather broadcasts prior to departure. The captain or first mate should personally monitor strong winds and electrical storms.
- Always keep accurate up-to-date charts of your boating area on board.

S - 2 FUELING

 **WARNING**

Do not smoke, extinguish all open flames, STOP all engines and other devices that could cause sparks, including the bilge blower. Do not use electrical switches or accessories. Shut OFF all stoves that may produce a spark or flame. Close all openings into the cabin area of the boat.

A. Recommendations

 **WARNING**

When fueling or having your boat fueled by an attendant, be sure the waste pump-out or fresh water fitting is not mistaken for the gas fill.

Although alcohol boosts the octane level of gasoline, it also attacks the rubber fuel distribution lines and even metal fuel system components. Alcohol will permeate most fuel hoses and other components such as fuel pump, gaskets and seals, and can also contribute to fuel system contamination.

The hoses we use in our boats are alcohol-resistant as are the materials used by the engine manufacturers. If only fuel containing alcohol is available, or the presence of alcohol is unknown, you must perform more frequent inspections for leaks and abnormalities. Any sign of leakage or deterioration requires your immediate attention. Refer to the engine manufacturer's recommendations on fuel type and octane ratings.

B. Preliminary Guidelines

1. Safely secure your boat to the dock.
2. Close all hatches, windows, doors and compartments to prevent accumulation of fuel vapors.
3. Ensure that a fire extinguisher is readily available.
4. Do not store fuel in areas that are not adequately ventilated.
5. Use only fuel lubricants recommended by the engine manufacturer.

C. Pumping Fuel

 **WARNING**

Follow engine manufacturer's recommendations for types of fuel and oil. Use of improper products can damage the engine and void the warranty.

1. Be sure to fuel in a well-lit area gasoline spills are unnoticeable under poor lighting or in the dark.
2. Remove the gas fill cover.
3. Insert the fuel supply nozzle, keeping it in contact with the fuel fill plate to guard against static produced sparks.
4. Stand away from the fuel tank vent and gas fill during fueling. Splashback may occur and can be an eye irritant and/or a fire hazard.
5. Avoid spillage. Wipe up any excess fuel immediately.
6. After pumping approximately 10 gallons of fuel into the fuel tank, inspect the engine and fuel tank area for any signs of leakage. If no leaks or other problems are detected, resume fueling.
7. Allow space at the top of the tank for thermal expansion.
8. If fuel cannot be pumped in at a reasonable rate, check for fuel vent blockage or a kink in the line.

D. After Fueling

1. Replace the gas fill cover and wipe up any fuel spilled. Discard rags used in a safe place ashore.
2. Open the engine compartment and all hatches, windows, doors and other compartments that were closed during fueling. Inspect these areas for the odor of fuel vapors and visible fuel leakage.

 **WARNING**

Investigate and correct any sign of fuel leakage or indication of vapors before starting engine. Do not run blower or operate any electrical switch until problem is corrected. Fire or explosion may result.

S - 3 LOADING PASSENGERS AND GEAR

When loading your boat, remember to distribute the load evenly. Keep the load low and do not overload. On certain Vista® models a capacity plate affixed to your boat states the maximum load capacity. The plate shows in pounds, the amount of persons and gear that the boat will safely handle under normal conditions. U. S. Coast Guard regulations establishes these load capacity ratings. Position passengers and gear so that the load is balanced.

NOTICE

The NMMA Yacht Certification rating (indicated by a yacht certification plate - see Preface page 13) places the responsibility on the captain to make the determination as to the appropriate load, load placement and number of passengers permitted aboard the vessel.

When loading, always step into the boat, never board by jumping. Have someone on the dock pass your gear aboard. Secure all gear firmly so it doesn't move or interfere with operation of the boat. Passengers should board the boat one-at-a-time and be seated.

IMPORTANT: Passengers are prohibited from riding on the bow with feet hanging over the side or ride while sitting on the stern, gunwales or seatbacks. The Coast Guard considers these acts to be negligent or grossly negligent operation. They are prohibited by law because falls from moving boats are a major cause of fatal recreational boating accidents.

IMPORTANT: The presence of the capacity plate does not relieve the boat operator from the responsibility of using common sense or sound judgment. Turbulent waters and adverse weather conditions will reduce the maximum load capacity rating of the boat.

S - 4 STARTING PROCEDURES

The operation and maintenance manual supplied with your engine provides pre-start, starting and cold-starting instructions. The following information is merely a guide and not intended to explain in detail all starting procedures and instructions. Refer to your engine owner's manual.

A. Preliminary Checks

1. Secure boat to the dock before attempting to start engine. The boat should be kept secure until the engine is running and warmed up.
2. Operate the bilge pump until the flow of water stops.
3. Make sure the throttle is in the neutral position and stern drive or outboard is lowered into water.
4. Make sure passengers seated in the bow area do not obstruct the driver's vision.

B. Starting



To prevent excessive exposure and reduce the possibility of carbon monoxide accumulation in the cockpit areas of the boat, the operator should provide adequate ventilation in each of these areas. Utilize hatches, doors, windows and side vents to increase air movement. See Section B-2 for information about the dangers of Carbon Monoxide.

Notice: Additional starting information is located in Section A.

1. Check all electrical systems and navigation lights.
2. Turn the battery switches to the ON position. If one of the designated engine batteries fails to start its respective engine, engage the "EMERGENCY START" switch at the helm and attempt to start the engine.
3. If your boat has fuel injection, turn the key to start the engine. Engine will not turn over if throttle is not in the neutral position.
4. Once engine has warmed up, check water temperature gauge to ensure engine temperature stays within optimum range. If temperature reading is abnormally high, stop engine immediately and inspect for cause of high reading.
5. With engine running, voltmeter should show a reading between 12 and 15 volts.
6. Check steering operation. Turn steering wheel full to port and starboard while observing outdrive movement.

7. Inspect for fuel odors and visible leaks in the fuel, oil, coolant, exhaust and power steering systems.
8. Make sure boat is securely moored to the dock and engine is idling. Then move the throttle forward and then aft and back to neutral to check for proper operation of the shifting motion. Be careful. Leave the engine in gear for only a second or two.

S - 5 MANEUVERING



Boat steering is not self-centering. Steering is effected by engine and propeller torque, trim tab setting, wave and current action and the speed of the hull through the water. Constant attention to steering is required for safe operation.

When all your pre-departure checks have been completed and the engine has warmed up, you will be ready to leave the dock. Take into account the amount of wind, tide current, and other forces that may affect your maneuvering as you leave the dock. Idle speeds work best when maneuvering to and from the dock. Do not forget to release the mooring lines.

A. Leaving the Dock

You are ready to leave the dock after the engine has warmed up. Check all gauges for appropriate readings before casting off. If oil pressure is abnormally low or engine temperature is abnormally high, stop the engine immediately. Check voltmeter to be sure the charging system is working properly. Check for fuel, oil, and exhaust leaks. Correct the cause of any abnormal condition before getting underway.

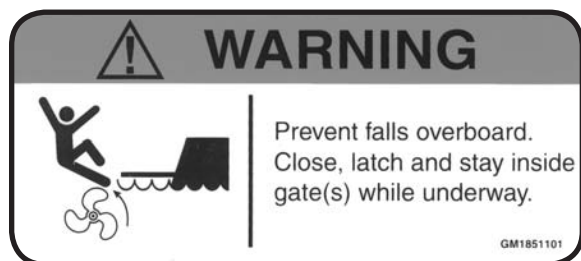

After making sure your boat is ready, check wind, tide, current and other forces that will affect the way you maneuver your boat away from the dock. Throw mooring lines off to your boat. Shift your boat's engine

into forward or reverse depending on whether you want to move the bow or the stern away from the dock first. Run your engine at a slow speed as you move away from the dock.

If you move the bow out first, watch that the stern of the boat does not swing into the dock or a piling.

Once away from the dock, devote some time to learning how to maneuver. Practice docking using an imaginary dock. Practice stopping and reversing.

B. Stopping

Boats have no brakes. Stopping is accomplished by backing down on the throttle. Practice stopping maneuvers and learn early how your boat reacts. From forward motion, pull the throttle back towards NEUTRAL. Depending on your speed, the distance the boat travels until it comes to a complete stop will vary. The ability to measure the distance will only be acquired through experience.

Once the boat has slowed and motor is idling, place the shift in REVERSE. Gradually increasing reverse power with the throttle will allow you to stop the boat in a very short distance.

NOTE: A boat will not respond to steering in reverse nearly as well as it does when going forward, so do not expect to accomplish tight turning maneuvers when backing up.

Remember that all boats steer by the stern (the feeling is much like steering your automobile in reverse). This means that the stern of your boat will swing in the direction opposite to your turn. For example, when you turn the helm wheel to the left, the stern of your boat will swing in the direction opposite to your turn. This is especially important to keep in mind when docking, operating in close quarters with other boats, or when approaching a swimmer or downed skier in the water.

Always look behind you and to both sides of the boat before slowing down. Tell your passengers your intentions to allow them time to make adjustments to their balance or positions.

Slowly pull back on throttles, glance back and see if a large following wave is approaching the transom. If so give the engines a little throttle as the wave arrives to keep wave from rolling over the transom.

Once you have spent enough time practicing maneuvers and have a feel for how the boat handles, you will be ready to run in open waters.

S - 6 ACCELERATION



Before accelerating to bring your boat on plane, be sure that the area in front of your boat is clear. The bow will rise out of the water momentarily before you plane and may temporarily obstruct your vision.

If you have never had your boat on plane before, choose a calm day for your first on plane experience. Never boat beyond your ability and experience.

Before bringing your boat “on plane”, check the entire area to make sure you have a clear, safe path. As you throttle up to accelerate, your boat will increase its angle of trim, causing the bow to ride high. From a maximum angle, the boat will level out to its planing attitude with continued acceleration. This maximum angle is known as the “hump”. Because visibility, handling, and performance are reduced, it is advisable to get “over the hump” as soon as possible. A few seconds at full throttle should get the boat over the hump and into its planing attitude.

After getting over the hump, accelerate until reaching a comfortable plane, then throttle down to cruising speed. This also will provide for better fuel efficiency.

S - 7 TRIMMING YOUR BOAT

A. Trim Tabs

Trim tabs are used to add lift to the boat’s stern, thereby changing the boat’s attitude (see Figure S-1). This lift can help the boat get on plane faster and remain on plane at slower speeds than if no tabs were used. Used independently, tabs can also correct listing conditions caused by crosswinds, unbalanced loading and quartering seas. Trimming your boat properly involves two separate procedures, trimming or tilting the lower unit (stern drives) and setting the trim tabs.

When you are sitting dead in the water, your drive should be down and the trim tab switches are in the BOW UP position. Accelerate until you get onto plane. At this point your boat will be plowing through the water

with the bow down too far. Trim the lower unit up slightly until the bow comes up. If you trim the lower unit out too far, your boat will porpoise or the propeller will cavitate, and the bow will slam up and down on the water. Your boat is trimmed correctly when it is just short of porpoising or propeller cavitation, under ideal running conditions.

Trim your boat to compensate for seas, winds, or uneven loads.

Head Seas	Trim drives in more than usual. Use tabs to keep bow down and go at a slower speed.
Following Seas	To prevent taking seawater The bow, trim drives out and keep tabs up to keep bow down
Listing Due to Quartering Seas, Beam Wind, or Uneven Load	Use tabs independently to adjust for list. If listing to starboard, press port bow down switch. If listing to port, press starboard bow down switch.

Remember that most boats react very slowly to trim tabs. Often boat owners do not give trim tabs time to work. Press the trim tab switches for only one second at a time and then allow some time for the boat to react. If the boat is still listing after a minute or two, press the trim tab switch again for a one second interval. The labels on the trim tab switches indicate what you want your boat to do, not what you want the tabs to do.

It is a good idea to take your boat out onto open water shortly after you get it and experiment with the trim tabs. After you get your boat onto plane, set the tabs in various positions and note how your boat reacts. This will give you a feel for how the trim tabs work.

It is possible to extend the cylinder life expectancy on your trim tabs. To do this, keep the cylinders retracted while at dockside. Press both trim tab controls down until tabs reach their full up position.

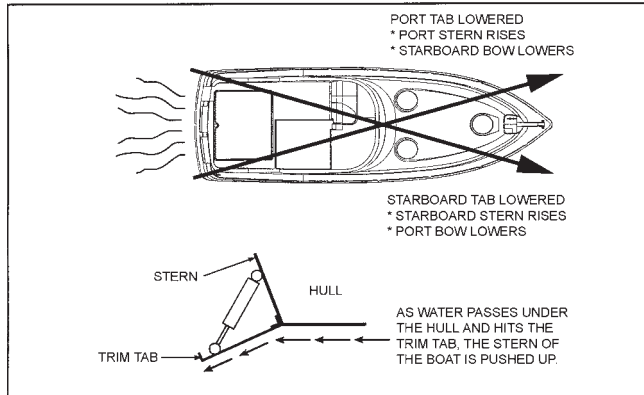

Figure S-1: Trimming the Boat with Trim Tabs

B. Tilt/Trim Control Switch

NOTE: Trim refers to the angle of the lower unit in relation to the bottom of the boat. With respect to trimming, the words in, down, under, and forward, have the same meaning as do up, out, and aft.

1. The standard trim control switch is located on the control lever handle.
2. The switch controls the position of the stern drive. Proper trim is very important in boating.
3. In the case of low or heavy bow attitude, the boat tends to “plow” (Figure S-2). The lower unit is trimmed too far under or forward. Trim the unit UP (out) to correct this situation.
4. If the bow is too high, the boat tends to “porpoise” (Figure S-4). The drive unit is trimmed up or out too far. Trim DN (in) to correct.
5. A good practice is to get underway (especially when fully loaded or pulling a skier) with the unit trimmed all the way DN (under). After the boat is on plane, adjust the trim out slightly to obtain the proper bow attitude and engine speed.
6. Trim also affects propeller selection and fuel efficiency. All models should be “propped” to be in the upper half of the maximum rpm range with the boat lightly loaded and the drive trimmed up to maximum. This configuration allows the engine to operate within the recommended rpm range with a heavy load.

The power unit should never be trimmed up to a point where the propeller cavitates (or slips). A rapid increase in engine rpm’s is evidence of cavitation. If this occurs accidentally while running

at full throttle, immediately lower the drive trim and reduce the throttle until the slipping stops. If necessary, have your dealer reset the trim limit switch (if provided) to avoid overtrimming in the future.

If the prop slips at lower planing speeds, the drive may be trimmed too high. Immediately lower the drive unit until the prop grabs again to restore efficiency.

7. Trimming out, in addition to raising the bow, also lifts the boat higher, gaining speed because less hull is in the water.

NOTE: Refer to the control instructions regarding the power trim controls installed on your boat.

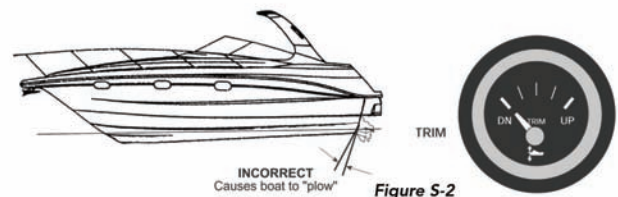

Figure S-2

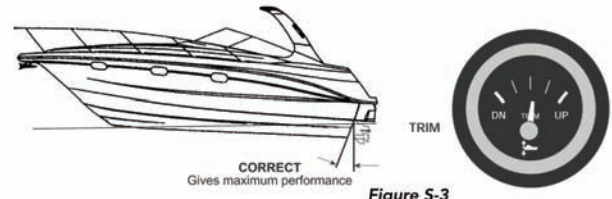

Figure S-3

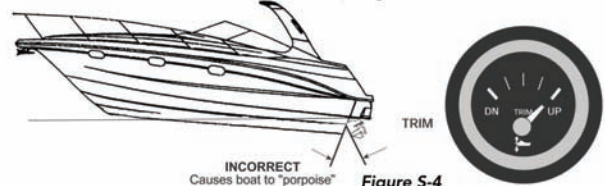

Figure S-4

Figures S-2–S-4: Trimming the Boat with Outdrive

S - 8 NAVIGATION LIGHTS

Although night activities are limited, cruising at night can be very pleasurable. It can also be dangerous if you don’t pay close attention to water levels and obstacles. Be especially careful of shallow waters and watch for submerged debris, rocks and other obstacles in the water. Your navigation lights are intended only to prevent collision, not to improve your night vision. You may choose to use a spotlight instead.

NOTE: It is illegal to use your spotlight as a headlight. Use it only temporarily to check the position of your boat and the surrounding area.

Your boat has one white (stern), one red (port) and one green (starboard) light. The stern light may be a removable pole light. To use the light, line up the two-prong plug in the pole with the receptacle in the base. Plug the light in, and lock it into place with lever/slide lock. When not in use, stow the light inside your boat for safekeeping. This light can be turned on or off at the helm.

Check lights for proper operation before heading out at night. You should also learn to identify the running light combinations for other vessels. We recommend that you participate in a boating safety course to further learn about navigation lights and safe boating practices.

The anchor lights and navigation lights are controlled by a switch at the helm. The anchor light switch allows you to turn on just the stern (white) light when anchored or moored. While underway, use the navigation light switch to turn on the stern (white), port (red) and starboard (green) lights. Lights are off when switches are in the OFF position.

S - 9 HAZARDOUS CONDITIONS

A. Storms

Storms sometimes appear without advance notice. Although weather information from meteorological observation and reporting stations is available, weather bureaus are known to have failures in their predictions or information gathering equipment. There is no substitute for a strong understanding of what action to take when the weather takes a turn for the worse. Many marinas fly weather signals. You should learn to recognize these signals and monitor your local weather forecasts before leaving port.

The present and forecasted weather conditions are of primary consideration, but a threat of possible storms should always be a concern. Observance of the following information will help in your safety afloat if storms do occur:

- Keep a watch on the horizon for approaching storm indicators.
- Turn radio ON. Dial in local weather station and monitor forecast. If your boat has a VHF radio, check the weather channels.
- The best possible situation is to return to a safe port if time allows.
- Close and secure all portals and hatches. Stow all loose gear below deck and tie down any gear required to remain on deck.
- Reduce speed as the seas build. Make sure all passengers are wearing their PFDs.
- If you lose power, keep the boat headed into the waves by rigging a sea anchor off the bow. If there is no sea anchor on board, use a canvas bucket or any object that will offer resistance.
- Radar reflectors (if installed on your boat) should be 18 inches diagonally and placed 12 feet above the waterline.

B. Fog

Fog is a result of either warm surface or cold surface conditions. You can judge the likelihood of fog formation by periodically measuring the air temperature and dew point temperature. If the spread (difference) between these two temperatures is small, you likely will incur a fog situation. Remember the following guidelines:

- Turn on running lights.
- As fog sets in, take bearings and mark your position on the chart while continuing to log your course and speed.
- Make sure all persons aboard are wearing their PFDs.
- If your boat has depth finding equipment, take sounding and match them with soundings on your charts.
- Station a person forward on the boat as a lookout.
- Reduce your speed. From time to time, stop engine and listen for fog signals.
- Sound the proper horn or fog bell at proper intervals to warn other boaters.
- If there is any doubt in continuing boat movement, anchor. Listen for other fog signals while continuing to sound the proper fog horn or bell for a boat at anchor.

C. Running Aground



To prevent boat damage, DO NOT use deck hardware or water ski pylon for towing. Use a commercial towing service.

Operating in shallow water can present a number of hazards. Sand bars in narrow inlets are constantly shifting, making it difficult to mark them with buoys. Sometimes sand bars are indicated by waves as they form into breakers when passing over sand bars. In coastal areas, tides can change water levels by as much as 30 feet. Check with local marinas or Coast Guard stations for tide tables and current charts.

If your boat runs aground, first check persons aboard for injury. Then check for damage to the boat. If the drive unit strikes an underwater hazard, check for boat and drive unit damage. If the engine vibrates excessively after striking an underwater obstruction, it may indicate a damaged propeller. If vibration is noticeable, return to port slowly to prevent further drive and engine damage from an out-of-balance condition. Watch the temperature gauge to make sure you do not overheat the engine.

If the boat is not taking on any water, it may be possible to rock the boat by shifting the weight of the passengers and gear and by raising the drive unit while reversing the engine.

If you ground your boat on a sand bar, shut down the engine and seek help from another boater or radio for help. See your dealer as soon as possible, as sand ingested in the engine cooling system can cause major engine damage.

D. Warning Markers

It is a good idea to find out about hazardous areas and how they are marked by asking your local authorities.

- Boaters must also recognize the flag designs which indicate that scuba divers are present and keep well clear of the area.
- Watch for swimmers. Swimming areas may not be marked. Steer clear from the area and always remain alert.
- Distress flags indicate a fellow boater is in need of assistance.

- Navigation markers serve as a means of identifying navigable routes and indicate water hazards. Boaters should become familiar with navigation markers and stay within marked boundaries and clear of hazards.

S - 10 REACTING TO EMERGENCIES

Be prepared to deal with emergencies before they happen. Try to formulate a plan for each type of emergency in advance so that decisions can be made quickly and without hesitation. Precious moments lost can mean the difference between losing and saving a life.

A. Flooding

If your boat starts taking on water, activate the bilge pump immediately. Make sure all passengers are wearing their PFDs. Open the engine compartment, look for the cause of the flooding. Check all hoses, through hull fittings, seacocks and strainers. If flooding occurs as a result of collision or grounding damage, call for assistance and head for shore if possible.

B. Capsizing and Man Overboard

By far, the largest number of boating fatalities involve capsizing and falling overboard accidents. By being prepared ahead of time with an appropriate plan of action, you can greatly lower your chances and your passengers' chances of becoming seriously injured.

C. Capsizing

Wear PFDs or have them readily available at all times. If your boat capsizes, and others were on board, locate them and guide them to the safety of the hull. Even if the boat floats in an upside-down position, stay with it. The boat hull is much easier for rescuers to spot than a human head sticking out of the water. DO NOT attempt to swim ashore, it may be further than it looks.

D. Man Overboard

Think through and follow these procedures if someone in your boat falls overboard.

- Remember, every second counts, you must act fast.

- Move throttles to idle position immediately and yell “MAN OVERBOARD.”
 - Throw some floating object overboard immediately. Keep your required Type IV PFD accessible at all times for such an emergency.
 - Keep the person in the water in sight at all times. Have a passenger do nothing but watch the person. Do not go into the water to help the victim. One person in the water is enough trouble.
 - Circle around quickly, approaching into the wind and waves. When the person is alongside, put the engine in neutral and throw them a Type IV PFD with a line attached or extend a paddle or boat hook within his/her reach.
1. Make sure all persons aboard are wearing their PFDs.
 2. If the fire is small, attempt to put it out with your fire extinguisher. If the fire is in the engine compartment, turn off the bilge blower. Do not open the engine compartment. This feeds oxygen to the fire and may cause it to flare up.
 3. If the fire gets out of control, execute a distress signal and call for help if equipped with a ship-to-shore radio.
 4. All persons aboard should jump overboard and swim a safe distance away from the flames.

IMPORTANT: All persons aboard should know the location and proper operation of the fire extinguishers.

E. Collision

If a serious collision occurs, you should first check the condition of all passengers aboard, then inspect your boat to determine the extent of damage.

1. Make sure all persons aboard are wearing their PFDs.
2. If you need help and your boat has a ship-to-shore radio, first contact the U. S. Coast Guard (VHF Channel 16) or other rescue authorities immediately.
3. Prepare to assist the other vessel unless your passengers and/or boat are in danger.
4. If the bow of the other boat penetrated your boat's hull, prepare to block the opening once the boats are separated.
5. Shore up the hole with a spare PFD or bunk cushion from your boat.
6. While blocking the hole, trim the boat so that the hole is out of the water.

F. Fire

Most fires are caused by electrical problems or careless fueling practices. A fire on board your boat is a serious emergency. You must work quickly to implement safety procedures. If a fire occurs, immediately stop the engine.

Guidelines

- Use only approved marine cooking and heating systems.
- Open flames demand constant attention.
- Keep flammable materials in approved containers in a overboard vented locker sealed from the interior of the boat.
- Ensure ventilation systems are unobstructed.
- Remove mooring covers before starting engine.
- Check the bilge for fuel leaks.
- Extinguish smoking materials carefully.
- Use special care with flame or high temperatures around urethane foam.
- Check cleaning products for flammability.
- Ventilate when cleaning or painting.
- Disconnect electrical system from its power source before performing maintenance.
- Replace breaker or fuse with same amperage device.
- Electrical appliances must be within rated amperage of boat circuits. Observe the boat carefully while the electrical system is being energized.

- Allow only a qualified marine electrician to service the boat's electrical system.

G. Medical Emergency

Accidents while boating can and may happen. Be prepared to handle these emergencies when they happen. Keeping a first aid kit and dry blankets on board can assist during these situations. It is also a good idea to contact your local Red Cross for information and training on first aid and CPR.

H. Propulsion Failure

Before you call for help regarding an engine or drive unit failure, it is a good idea to eliminate the possibility of simple problems. Turn off the engine and check to see that (1) there is fuel in the tank; (2) the engine cooling intakes on the outdrive are not clogged; (3) props are clean and free of weeds, netting, etc.; (4) no hoses are leaking; (5) there is oil in the engine.

Once you have checked out the possibilities listed above and find they are not the problem, call for help giving your position and a detailed description of your boat.

I. Control Failure

In the unlikely event of a shift/throttle failure, shut down the engine immediately. Carefully check the control connections in the engine compartment to see if they are secure. If not, try to locate the attaching hardware and reassemble. If that is not possible, try to use whatever is available such as paper clips, hair clips, tape, etc., to secure the connections. If a temporary repair is made, return to port at the slowest steerable speed and be prepared to take emergency action should the temporary repair fail also. Have your dealer make repairs before using the boat again.

J. Steering Failure

If a problem with the steering occurs, shut down the engine immediately. Check the connections to the drive unit in the engine compartment. Some boats have a push/pull cable while others will have hydraulic hose connections. With cable connections, check the attaching hardware and tighten it if necessary. If you have hydraulic hose connections, check to see if they are leaking. If so, tighten the connections and check the hydraulic fluid reservoir level. Most stern drives are power assisted and have their own hydraulic reservoir and engine mounted drive pump; check the

level of reservoir and drive pump belt. If the steering is not operating properly, do not operate the boat and call for assistance.

K. Additional Underway Information

- Always be aware of local laws on noise limits. Noise means engine noise, radio noise or even yelling by people on your boat. Good seamanship demands that you operate your boat quietly so as not to infringe on the rights of others. Don't use thru-transom exhaust unless you are well off shore.
- You are responsible for any damage or injury caused by your boat's wake. Observe no wake speed zone warnings. Operate your boat with regard for the safety of other boats and people in your boating area.
- Keep your engine well tuned to decrease exhaust hydrocarbon emissions that pollute the air and water.

S - 11 RETURNING TO SHORE

A. Docking

Always approach the dock slowly. Think before acting. If you are wondering whether your boat will fit in a space against a dock, remember that pilings are often (but not always) spaced 10 feet apart.

Remember that it is easier to control a boat in reverse because a boat steers from the stern. When backing into a slip, back so that bow swings into the wind if possible. You will have more control.

If possible, come in against the wind or current, whichever is stronger. Approach the dock at a 30-45° angle. As the boat nears the dock, slowly swing parallel to it. Tie the bow line first; then the stern.

If wind or current is moving toward the dock, move parallel to the dock further out. Let the wind or current push you in. Tie the stern first, then the bow.

Use extreme caution if wind or current is from your stern. Back in towards the dock slowly at a slight angle with engine in slow reverse. Gently swing parallel. Tie stern first, then the bow.

If the weather looks bad, use spring-lines from the bow and stern to dock amidships of the boat. Tie up on the downwind side of the dock. If the wind is changeable, place fenders over the side between the boat and the dock.

B. Mooring

After you have positioned your boat next to the dock, you must secure it with mooring lines to keep it in position. Mooring lines must be long enough to secure your boat in any docking situation. For example, the length of the lines for a 16-foot runabout should be at least 15 feet. An eye splice at the end of each line works well with bow or stern cleats.

The mooring lines you will use most often are the bow line, the stern line, and spring lines as shown on Figure S-5. Each line has a specific purpose. The bow line and the stern line secure your boat's bow and stern. The two spring lines keep your boat from moving forward or backward when you are moored alongside a dock.

If you are mooring your boat for a short time, bow and stern lines may be the only lines you will need. If you are mooring your boat for a longer time or the currents are swift, you should use spring lines. The stern spring line leads from the boat's stern cleat forward to the piling or cleat on the dock. The bow spring line leads from the bow cleat aft to the dock.

If you are mooring your boat in a slip, bow and spring lines, port and starboard, will keep your boat in position.

NOTE: If tides are a consideration, be sure to leave slack in the lines to make up for the rise and fall of the water while your boat is docked.

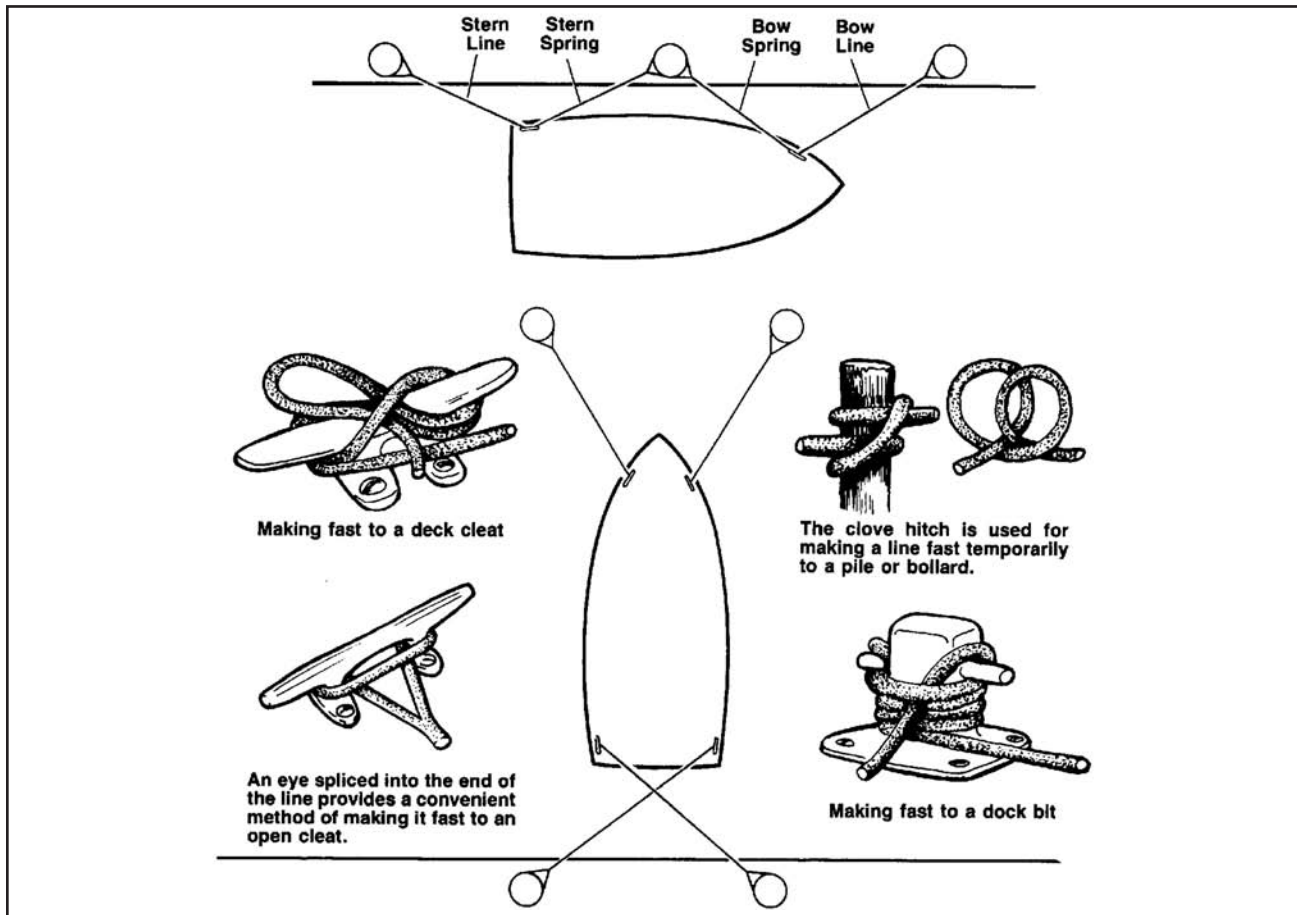

Figure S-5: Mooring Lines

ABAFT - Toward the rear of a boat.

ABEAM - At right angles to the keel of the boat.

ABOARD - On the boat.

ABREAST - Side by side.

ADRIFT - Loose, not on moorings or towline.

AFT - Moving toward the stern, you are going aft.

AGROUND - Stuck fast to the bottom.

AHEAD - In a forward direction.

ALEE - Away from the direction of the wind; opposite of windward.

ALOFT - Above the deck.

AMIDSHIPS - 1. An object or area midway between the bow and stern. 2. An object or area midway between the port side and the starboard side of a vessel.

AMPERE - The standard unit used to measure the draw of an electrical current.

ANCHOR RODE OR ROPE - The line (chain) connecting a vessel to its anchor.

ANCHOR BALL - A black, circular, day signal hoisted to show that a vessel is anchored. Replaced at dusk by the anchor light.

ASTERN - Anywhere behind the boat, a reverse direction, opposite of ahead.

ATHWARTSHIPS - A line, or anything else, running perpendicular to the fore-and-aft center line of a boat.

BATTEN - A strip of wood or metal used to secure tarpaulin(s) in place over a hatch. To batten down means to secure for rough weather.

BEAM - 1. The widest distance across a boat from the outside skin on one side to the outside skin on the other. 2. A transverse structural member that stiffens and supports a portion of the deck.

BEAM WIND - A wind blowing against the side of the vessel, perpendicular to the long axis of the vessel.

BILGE - The lowest interior area of a hull, used to collect water that has entered.

BILGE PUMP - A pump intended for removal of spray, rainwater, and the normal accumulation of water due to seepage and spillage; not intended for damage control.

BINNACLE - The stand or support for a magnetic compass occasionally used to mean helm.

BITT - A heavy and firmly mounted piece of wood or metal used for securing lines.

BLOCK - A wooden or metal case enclosing one or more pulleys and having a hook, eye, or strap by which it may be attached.

BOLLARD - A single post (wood, metal, or concrete) on a dock, pier, or wharf used to secure a vessel's lines.

BONDING - The electrical connection of exposed metallic, non-current carrying components to a common point on the main engine block.

BOW - The front end of the boat.

BOW LINE - A docking line leading from the bow.

BREAKER - A single breaking, plunging or spilling wave.

BREAKER LINE - The outer limit of the surf. However, all breakers may not be in a line. They can occur outside the breaker line.

BRIDGE - The main vessel control station.

BROACH - The turning of a boat parallel to the waves, subjecting it to possible capsizing.

BULKHEADS - The interior walls of a boat.

BULWARK - The side of a vessel when carried above the level of the deck.

BUOY - An anchored float used for marking a position on the water, a hazard, or a shoal.

CAPSIZE - To turn over.

CAPSTAN - A machine that moves a cylindrical device on a shaft for the purpose of hauling up an anchor.

CAST OFF - To let go.

CATAMARAN - A twin-hulled boat, with the hulls being side-by-side.

CHINE - The intersection of a boat's bottom and side. If this intersection is rounded, it is a "soft" chine. If the intersection is squared off, it is a "hard" chine.

CHOCK - 1. A fitting or hole in a railing or deck through which a mooring or anchor line is routed.
2. A wedge used to secure an item in place.

CIRCUIT BREAKER - A device used to interrupt an electrical circuit when current flow exceeds a predetermined level.

CLEAT - A double-ended deck fitting to which lines are secured; usually anvil-shaped.

COAMINGS - Raised lips around cockpits or hatches used to keep water from entering

COCKPIT - An exposed deck area (usually aft) that is substantially lower than the adjacent deck.

COMBER - A wave on the point of breaking. A comber has a thin line of white water on its crest, known as "feathering."

COMPANIONWAY - The steps or ladder leading downward from a deck.

COMPARTMENTS - Rooms divided by bulkheads.

COUNTER - The overhang at the stern of a boat.

CRADLE - A framework, generally made of wood, used to support a boat when it is out of the water.

CREST - The top of a wave, breaker or swell.

CUDDY - A small sheltered cabin in a boat.

CURRENT - 1. The movement of water,
2. The flow of electrical charge.

DEAD AHEAD - Directly in front of the boat.

DEAD RECKONING - A plot of courses steered and distances traveled through the water.

DECK - A permanent covering over a compartment, hull or any part thereof.

DESIGNATOR - Model identifier or model name.

1. to mark or point out; indicate; show; specify.
2. to denote; indicate; signify.
3. to name; entitle; style.

DINGHY - A small, open boat used for ship to shore transportation.

DISPLACEMENT - The weight of water displaced by the hull of a vessel.

DISPLACEMENT HULL - A hull that "displaces" a volume of water equal to the weight of the boat. A hull designed to run in the water rather than on top of the water. When a displacement hull moves through the water, it pushes that water out of the way. Water will then flow around the hull and fill the "hole" the boat leaves astern.

DOCUMENTED VESSEL - Documented yachts have been specially registered with the U.S. Coast Guard. All documented yachts must have their name and home (hailing) port marked on some conspicuous place on the hull. Numbering is not required. Advantages include legal authority to fly the yacht ensign, privilege of recording bills of sale, and other instruments of title with federal officials, and preferred status for mortgages. Documentation does not exempt the unit from any State or Federal taxes. All safety and equipment regulations still apply.

DOLPHIN - A group of piles driven close together and bound with wire cables into a single structure.

DRAFT - 1. The depth of a boat from the actual water line to the bottom of the lowest part of the boat (e.g., the propeller tip or rudder). 2. The depth of water necessary to float a boat.

DROGUE - Any device streamed astern to check a vessel's speed, or to keep its stern up to the waves in a following sea.

DYE MARKER - A brightly colored chemical that spreads when released into water; normally used to attract attention.

EBB TIDE - A receding tide.

EVEN KEEL - To be floating evenly without listing to either side.

EXHAUST SYSTEM - The means by which the hot engine (or generator) exhaust gases are moved from the engine to an outboard port and then released into atmosphere.

EYE SPLICE - A permanent loop spliced in the end of a line.

FAST - Said of an object that is secured to another.

FATHOM - Six feet.

FENDER - A device (usually constructed of rubber or plastic) positioned so as to absorb the impact between vessels or dock.

FETCH - The unobstructed distance that the wind can blow over the water to create waves.

FLARE - 1. Outboard curve of the hull as it comes up the side from the waterline; the reverse of tumble home. 2. A pyrotechnic device used for emergency signaling.

FLAT - A small deck that is built below decks, specifically to support a piece of equipment.

FLEMISH - To coil down a line or rope on deck in a flat, circular, concentric arrangement.

FLOTSAM - Floating wreckage, trash or debris.

FLUKE - The palm of an anchor.

FOAM CREST - The top of the foaming water that speeds toward the beach after a wave has broken, commonly referred to as "white water."

FOLLOWING SEA - A sea (waves) moving in the same direction as a vessel.

FORE-AND-AFT - A line, or anything else, that runs parallel to the longitudinal center line of a boat.

FOREFOOT - The portion of a vessel's keel that curves upward to meet the stem.

FOREPEAK - A compartment in the bow of a boat.

FORWARD - Toward the bow.

FREEBOARD - The minimum vertical distance from the surface of the water to the gunwale.

FREQUENCY - The number of crests passing a fixed point at a given time.

FRONTS - Where opposing warm and cold air masses meet, generally producing a band of wet, stormy weather wherever they meet.

GALLEY - The kitchen area of a boat.

GALVANIC CORROSION - A potential electrical difference exists between dissimilar metals immersed in a conductive solution (e.g., salt water). If these metals touch or are otherwise electrically connected, this potential difference produces an electron flow between them. The attack on the less corrosion resistant metal is usually increased and the attack on the more resistant metal is decreased, as compared to when these metals are not touching.

GANGWAY - The area of a ship's side where people board and disembark.

GASKET - A strip of sealing material, usually rubber, set along the edge of a water or gas tight door, port, cover or hatch.

GELCOAT - The thin outer layer of pigmented plastic covering a fiberglass vessel.

GLAND - The movable part of a stuffing box, which when tightened, compresses the packing.

GROUND - Electrical term meaning the electrical potential of the earth's surface, which is zero.

GROUND SPEED - A vessel's speed made good over the earth's surface along a course or track.

GROUND TACKLE - The anchor, anchor rodes, and other fittings that are used to secure a vessel at anchor or dockside.

GUNWALE - 1. The line where the upper deck and the hull meet. 2. The upper edge of a boat's side.

HALYARD - A line used to hoist a flag or pennant.

HATCHES - Cover on hatchways.

HATCHWAYS - Access ways through decks.

HARDTOP - A permanent cover over the cabin or cockpit.

HAWSER - A heavy rope or cable used for mooring or towing.

HEAD - A toilet or lavatory area.

HEADING - The direction that a vessel is going with reference to true, magnetic, or compass north.

HEADWAY - The forward motion of a vessel through the water.

HEAVE TO - To bring a vessel up in a position where it will maintain little or no headway, usually with the bow into the wind.

HEAVY WEATHER - Stormy weather with high seas and strong winds.

HEEL - To tip to one side.

HELM - The wheel or tiller that manually controls the boat's steering system.

HELMSMAN - The individual steering the vessel.

HIGHS - A center of pressure surrounded by lower pressure on all sides. Caused by a mass of cooler, sinking, drier air. This raises the area ground level air pressure and provides clear skies.

HULL - The main body of a boat.

INBOARD - 1. From either the port or starboard side of a boat toward the fore-and-aft centerline of a boat. 2. The dock side of a moored boat.

INLAND RULES - Nautical "Rules-of-the-Road" that apply in U.S. lakes, rivers, and coastal waters.

INTERNATIONAL RULES - Nautical "Rules-of-the-Road" that are in effect by international agreement to the high seas.

ISOBARS - Lines of equal air pressure that connect all the local points on a weather map. These lines are usually closed and define high or low pressure air masses.

ISOTHERMS - Isotherms are lines that are similar to Isobars except that Isotherms connect all the points that are of equal temperature.

JETSAM - Refuse that sinks when discharged overboard.

KEDGE(S) - One or more anchors set out from a grounded vessel, usually astern, to 1) keep it from being driven further aground and 2) to aid in refloating.

KEEL - 1. The centerline of a boat hull bottom running fore and aft, 2. The backbone of a vessel.

KNOT - 1. A maritime unit of speed equal to one nautical mile per hour (6076 feet). 2. A term for hitches and bends.

LANYARD - A short line made fast to an object to secure it.

LATITUDE - The measure of angular distance in degrees, minutes, and seconds, north or south of the equator.

LAZARETTE - Storage compartment in the deck at the stern.

LEADLINE - A weighted line used to take depth measurements.

LEE - The direction opposite that of the wind.

LEEWARD - Away from the wind.

LIST - A vessel that inclines to port or starboard.

LORAN - Long Range Navigation. An electronic system whereby a navigator can determine position regardless of weather.

LONGITUDINAL - Running lengthwise.

LOWS - A region of low atmospheric pressure. Hurricanes are extremely concentrated low pressure systems.

LUBBER LINE - A mark or line on the compass parallel to the keel indicating forward.

MAST - A spar that is set upright to support lighting, rigging, or sails.

MODEL DESIGNATOR - Model identifier or model name.

MOORING - An arrangement for securing a boat to a mooring buoy or pier.

NAVIGATION LIGHTS - A set of red and green or white lights which must be shown by all vessels between dusk and dawn.

OVERHEAD - A ceiling or roof of a vessel.

OVERBOARD - Over the side of the boat.

OUTBOARD - 1. From the fore-and-aft centerline of a boat toward both the port and starboard sides. 2. The seaward side of a moored boat. 3. An engine that is mounted externally onto the transom of a boat.

PAINTER - A line to the bow of a small boat used for making fast.

PASSAGEWAY - A corridor or hallway aboard ship.

PENNANT - The line by which a boat is made fast to a mooring buoy; also pendant.

PERSONAL FLOATATION DEVICE (PFD) - A life preserver.

PIER - A loading platform that extends at an angle from the shore.

PILASTER - A rectangular structural support column that is an extension of the port and starboard aft cabin sides and which supports the hardtop and flybridge.

PILING - Support, or protection for wharves, piers, etc.

PITCH - 1. The vertical (up and down) motion of a bow in a seaway, about the athwartships axis. 2. The axial advance of a propeller during one complete revolution.

PITCHPOLING - A boat being thrown end-over-end.

PLACARD - A board or stiff card bearing a notice, advertisement, message, etc.

PLANING HULL - At slow speeds, a planing hull will displace water in the same manner as a displacement hull. As speed is increased, the hull provides a lifting effect up onto the surface of the water.

POINT - One of 32 points of the compass that is equal to 11-1/4 degrees.

PORT - 1. Looking forward, the left side of a boat, 2. A harbor, 3. An opening for light or ventilation or passage of material in the side of a boat.

PORT BEAM - The left-center of a boat.

PORT BOW - Facing the bow, the front left side.

PORT QUARTER - Looking forward, a vessel's left rear section.

QUARTER - The sides of a boat aft of amidships.

QUARTERING SEA - Sea coming on a boat's quarter.

RED-RIGHT-RETURNING - A term for helmsmen that buoys and day markers are on the right when returning from seaward.

REEF - A shallow underwater barrier.

REEVE - To pass a line through a block or other opening.

RIDGES - High pressure fingers extending out from a high.

RODE - The anchor line or chain.

RUNNING LIGHTS - Lights required to be shown on boats underway between sundown and sunup.

RUDDER - A vertical plate for steering a boat.

SALON - The main social cabin on a vessel, usually the largest area, occasionally referred to as the deckhouse.

SCREW - A propeller.

SCUPPER - A drain from the edge of a deck that discharges overboard.

SEACOCK - A positive action shut-off valve connected directly to the hull seawater intake and discharge piping.

SERIES - A group of waves which seem to travel together and at about the same speed.

SHACKLE - A “U” shaped connector with a pin or bolt across the open end.

SHAFT - The long, round member that connects the engine or transmission to the propeller.

SHAFT LOG - A fitting at the hull bottom where the shaft connecting an engine to its propeller penetrates the hull. A shaft log permits the shaft to rotate while simultaneously preventing water from entering the hull.

SHEER - The top of the hull’s curvature at the deck line from the bow to the stern.

SHEER STRAKE - The upper edge of the hull, immediately below the deck.

SHEET BEND - A knot used to join tow ropes.

SHOAL - An area of shallow water.

SILENCER - A baffled chamber installed in an exhaust system to reduce the noise.

SOLE - Term for deck, cabin or cockpit floor.

SPAR - A general term for booms, masts, yards etc.

SPRING LINE - A pivot line used in docking, undocking, or to prevent the boat from moving forward or astern while made fast to a dock.

STARBOARD - Looking forward, the right side of a boat.

STARBOARD BEAM - The right-center of a boat.

STARBOARD BOW - When facing the bow, the front right side.

STARBOARD QUARTER - When looking forward, the right rear section of the boat.

STEERAGEWAY - The lowest speed at which a vessel can be controlled by the steering wheel.

STEM - The leading edge of a boat’s hull.

STERN - The back of a boat.

STRINGER - A fore and aft continuous member used to provide a vessel longitudinal strength.

STRUT - A propeller shaft support that is below the hull.

SUMP - A pit or well into which water is drained.

SUPERSTRUCTURE - Deck houses and other structures extending above the deck.

THWART - A seat or brace running laterally across a boat.

THWARTSHIPS - At right angles to the centerline.

TILLER - A bar or handle for turning a boat’s rudder, or motor.

TOPSIDE - To go up to the top deck.

TRANSOM - The stern cross-section of a square sterned boat

TRANSVERSE - Across the vessel; athwartships.

TRIM - Fore and aft balance of a boat.

TROUGH - 1. The valley that exists between waves. 2. A trough is the opposite of a ridge in that it is an elongated low-pressure area extending out from a low. A trough normally indicates unsettled weather.

TUMBLE HOME - The opposite of flare. The shape of the hull as it moves outboard going down from the gunwale to the waterline or chine.

UNDERWAY - Movement. Usually referring to a vessel proceeding forward.

V-BOTTOM - A hull with the bottom section in the shape of a “V.”

V DRIVE - A drive system that has the output of the engine facing forward and coupled to a transmission. The prop shaft is then coupled to the transmission.

WAKE - Moving waves, track or path that a boat leaves behind it when moving across the water.

WATER LINE - The line of the water on the hull when the vessel is afloat.

WATCH - A 4 hour duty period while at sea.

WAVES - Waves are periodic disturbances of the sea's surface, caused by wind, seaquakes, and the gravitational pull of the moon and the sun.



Copy this page and fill out before going boating. Leave the completed copy with a reliable person who can be depended upon to notify the Coast Guard, or other rescue organization, should you not return as scheduled. **DO NOT** file this plan with the Coast Guard.

Name _____ Telephone _____

Description of Boat _____ Type _____ Color _____ Trim _____

Registration Number _____

Length _____ Name _____ Make _____

Four Winns® Hull Identification Number _____

Other Information _____

Persons Aboard: Name	Age	Address	Telephone

Engine Type _____ HP _____

Number of Engines _____ Fuel Capacity _____

Survival Equipment:

PFDs _____ Flares _____ Mirror _____

Smoke Signals _____ Flashlight _____ Food _____

Paddles _____ Water _____ Anchor _____

Raft or Dinghy _____ EPIRB _____ Sea Anchor _____

Navigation Equipment:

Compass _____ Loran _____ GPS _____ Radar _____

Radio: Yes _____ No _____ Type _____ Frequency _____

Phone: Yes _____ No _____ Phone Number _____

Destination _____ Estimated Time of Arrival _____

Expected to Return By _____

AutoType _____ License No. _____ Where _____

If not returned by _____ call the Coast Guard, or _____
Local Marine Authority

Coast Guard Telephone Number: _____

Local Marine Authority Telephone Number: _____

BOAT MODEL	
HULL IDENTIFICATION NUMBER	
ENGINE MODEL	
ENGINE SERIAL NUMBER(S)	
DRIVE MODEL	
DRIVE SERIAL NUMBER(S)	
PROPELLER DIAMETER	
PROPELLER PITCH	
PROPELLER PART NUMBER(S)	
OIL FILTER NUMBER	
BOAT COLOR	
COCKPIT UPHOLSTERY COLOR	
CABIN UPHOLSTERY COLOR	
FUEL CAPACITY	
FUEL: ESTIMATED AVG. GALLON/HR USAGE	
IGNITION KEY NUMBER(S)	
GLOVE BOX KEY NUMBER	
COMPANIONWAY KEY NUMBER	
TRAILER MODEL	
TRAILER COLOR	
TRAILER SERIAL NUMBER	
TRAILER TIRE SIZE & MANUFACTURER	
SELLING DEALER	
ADDRESS	
CITY & STATE	
PHONE NUMBER	
MISCELLANEOUS	

(Note: Representative Location Only - availability and locations of equipment may vary depending on optional equipment installed. Locations and availability is subject to change without notice).

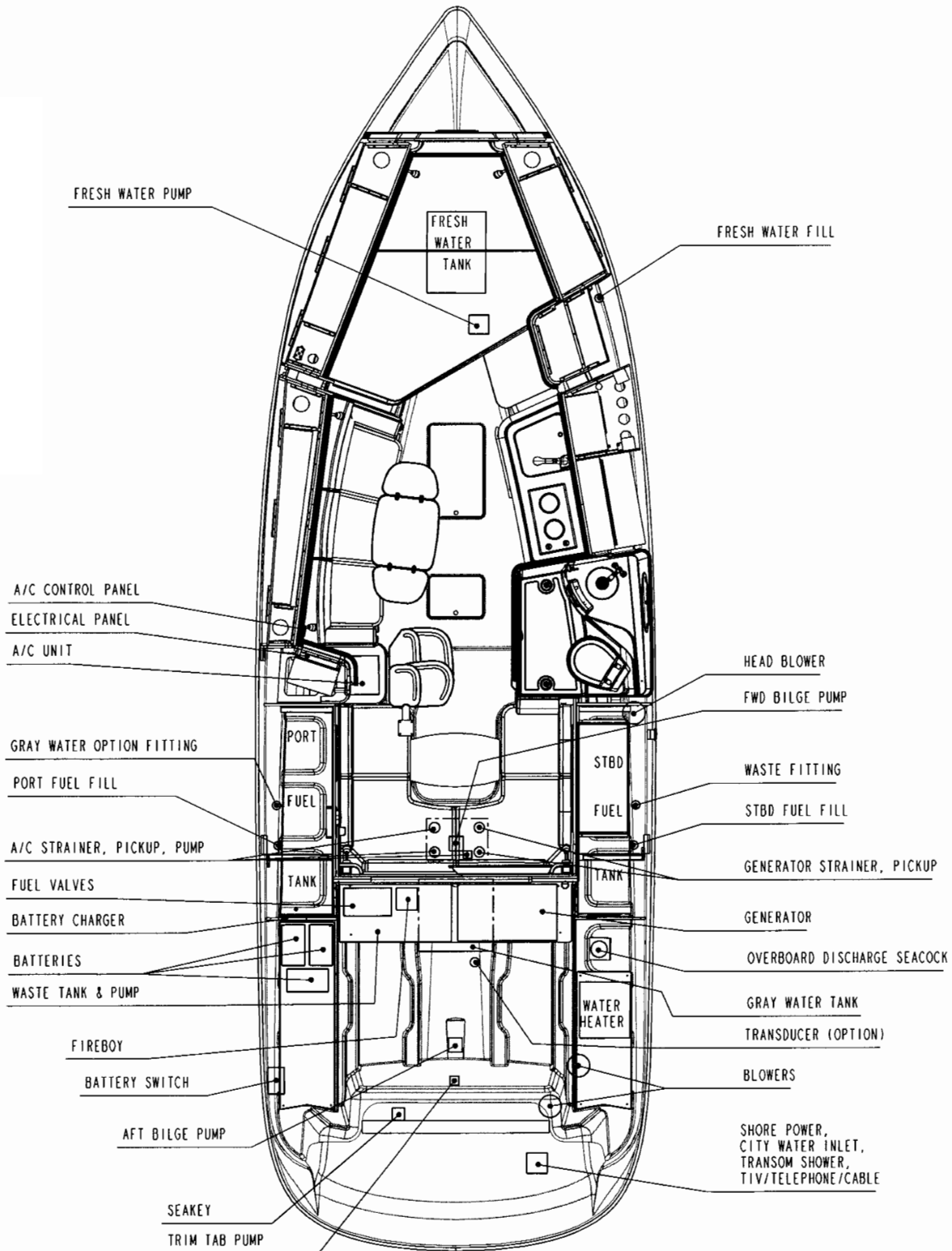

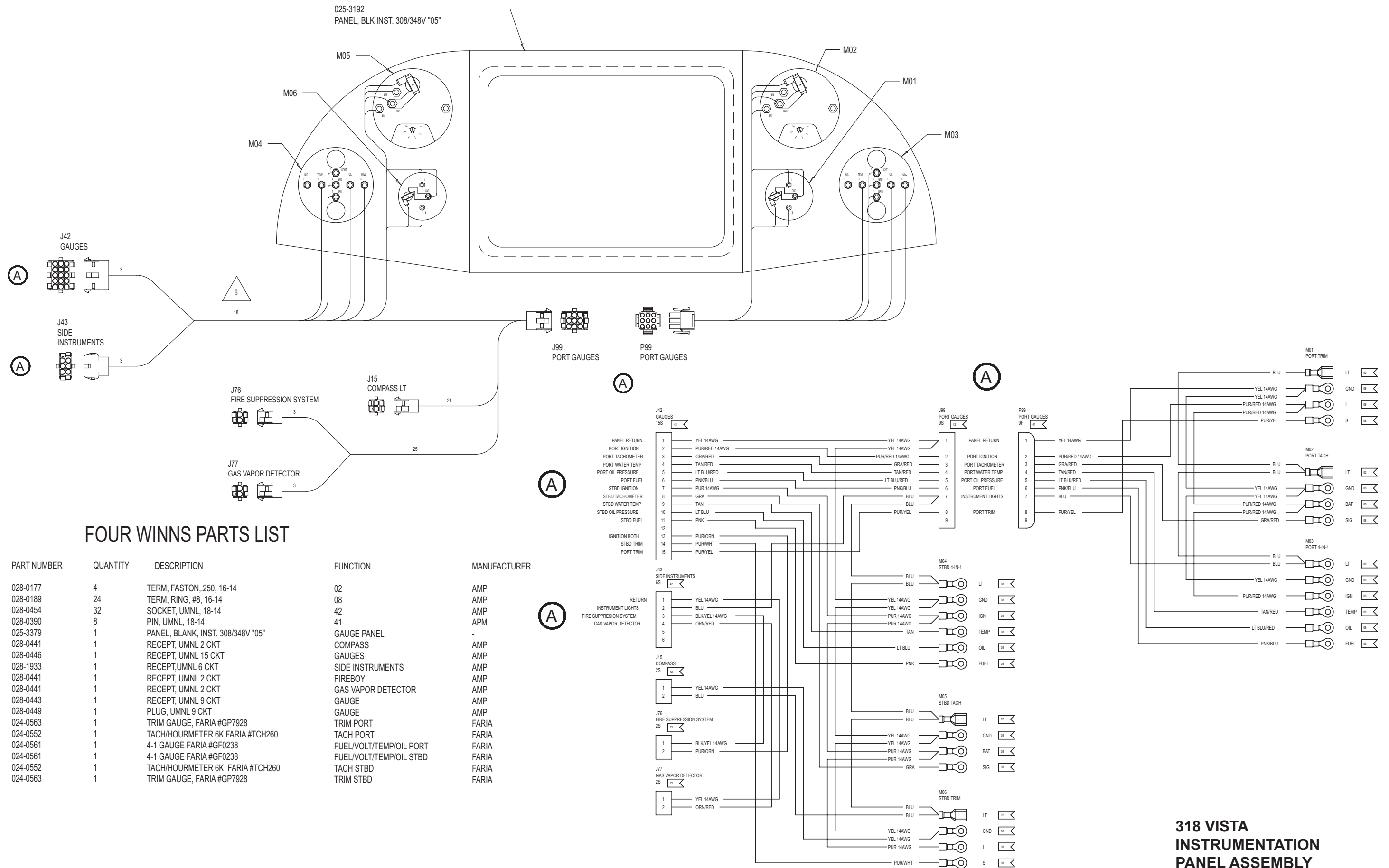

FOUR WINNS PARTS LIST

ITEM	PART NUMBER	QUANTITY	DESCRIPTION	FUNCTION	MANUFACTURER
-	028-0177	4	TERM, FASTON, .250, 16-14	02	AMP
-	028-0189	24	TERM, RING, #8, 16-14	08	AMP
-	028-0454	32	SOCKET, UMNL, 18-14	42	AMP
-	028-0390	8	PIN, UMNL, 18-14	41	APM
-	025-3379	1	PANEL, BLANK, INST. 308/348V *05"	GAUGE PANEL	-
J15	028-0441	1	RECEPT, UMNL 2 CKT	COMPASS	AMP
J42	028-0446	1	RECEPT, UMNL 15 CKT	GAUGES	AMP
J43	028-1933	1	RECEPT, UMNL 6 CKT	SIDE INSTRUMENTS	AMP
J76	028-0441	1	RECEPT, UMNL 2 CKT	FIREBOY	AMP
J77	028-0441	1	RECEPT, UMNL 2 CKT	GAS VAPOR DETECTOR	AMP
J99	028-0443	1	RECEPT, UMNL 9 CKT	GAUGE	AMP
P99	028-0449	1	PLUG, UMNL 9 CKT	GAUGE	AMP
M01	024-0563	1	TRIM GAUGE, FARIA #GP7928	TRIM PORT	FARIA
M02	024-0552	1	TACH/HOURMETER 6K FARIA #TCH260	TACH PORT	FARIA
M03	024-0561	1	4-1 GAUGE FARIA #GF0238	FUEL/VOLT/TEMP/OIL PORT	FARIA
M04	024-0561	1	4-1 GAUGE FARIA #GF0238	FUEL/VOLT/TEMP/OIL STBD	FARIA
M05	024-0552	1	TACH/HOURMETER 6K FARIA #TCH260	TACH STBD	FARIA
M06	024-0563	1	TRIM GAUGE, FARIA #GP7928	TRIM STBD	FARIA

**318 VISTA
INSTRUMENTATION
PANEL ASSEMBLY**

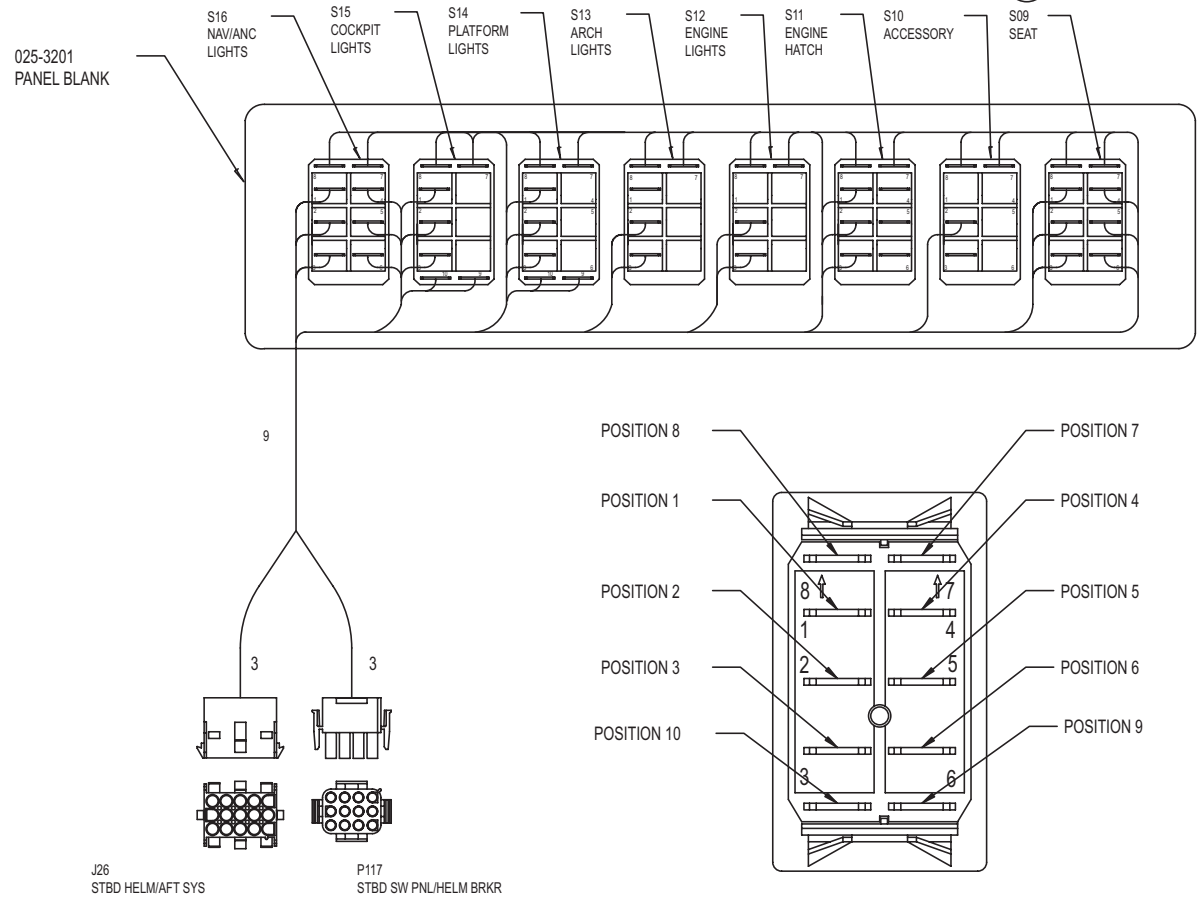

FOUR WINNS PARTS LIST

ITEM	PART NUMBER	QUANTITY	DESCRIPTION	FUNCTION	MANUFACTURER
-	028-0177	20	RECEPT,FASTON ,250,16-14	02	AMP
-	028-0179	23	RECEPT,FASTON ,250,12-10	07	AMP
-	028-0390	11	PIN,UMNL,18-14	41	AMP
-	028-0454	13	SOCKET,UMNL,18-14	42	AMP
-	028-3201	1	PANEL,BLANK STBD SWITCH	-	-
J26	028-0446	1	RECEPT,UMNL,15 CKT	STBD HELM/AFT SYSTEMS	AMP
P117	028-0451	1	PLUG,UMNL,12 CKT	STBD SW PNL/HELM BRKR	AMP
S09	028-1979	1	SWITCH,CONTURA V,DPDT,(ON)-OFF-(ON)	POWER SEAT	CARLING
S10	028-1907	1	SWITCH,CONTURA V,SPST,ON-NONE-OFF	ACCESSORY	CARLING
S11	028-1898	1	SWITCH,CONTURA V,DPDT,(ON)-OFF-(ON)	ENGINE HATCH	CARLING
S12	028-1958	1	SWITCH,CONTURA V,SPST,ON-NONE-OFF	ENGINE ROOM LIGHTS	CARLING
S13	028-1908	1	SWITCH,CONTURA V,SPST,ON-NONE-OFF	ARCH LIGHTS	CARLING
S14	028-1960	1	SWITCH,CONTURA V,DPDT,ON-NONE-ON	PLATFORM LIGHTS	CARLING
S15	028-1957	1	SWITCH,CONTURA V,SPDT,ON-NONE-ON	COCKPIT LIGHTS	CARLING
S16	028-1899	1	SWITCH,CONTURA V,DPDT,ON-OFF-ON	NAV/ANC LIGHTS	CARLING

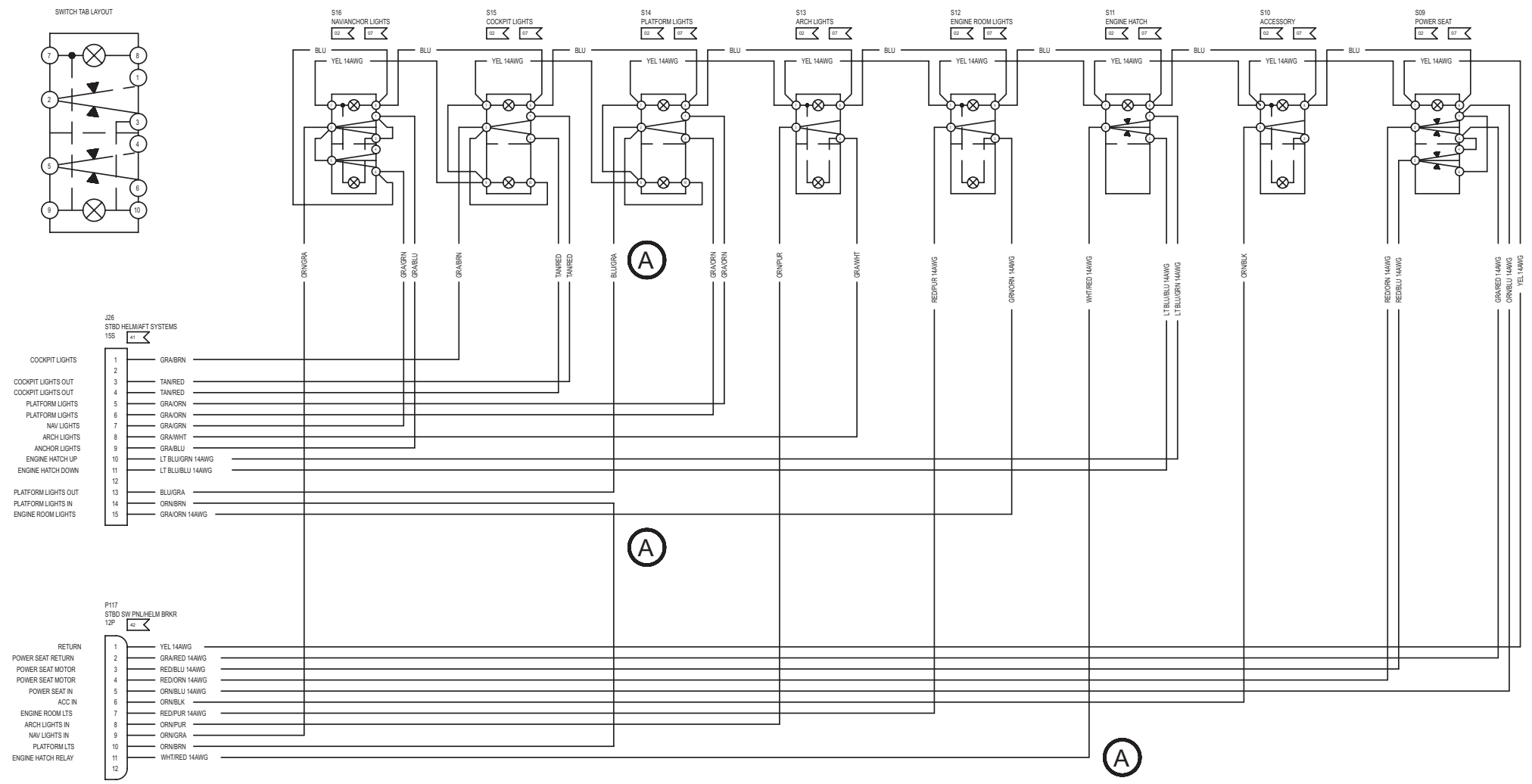

318 VISTA
STARBOARD HELM SWITCH
PANEL ASSEMBLY

Owner's Manual Page 192

025-3200
PANEL BLANK

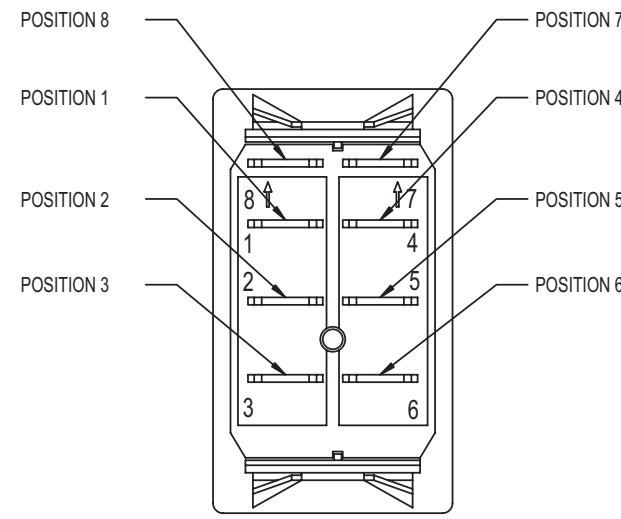
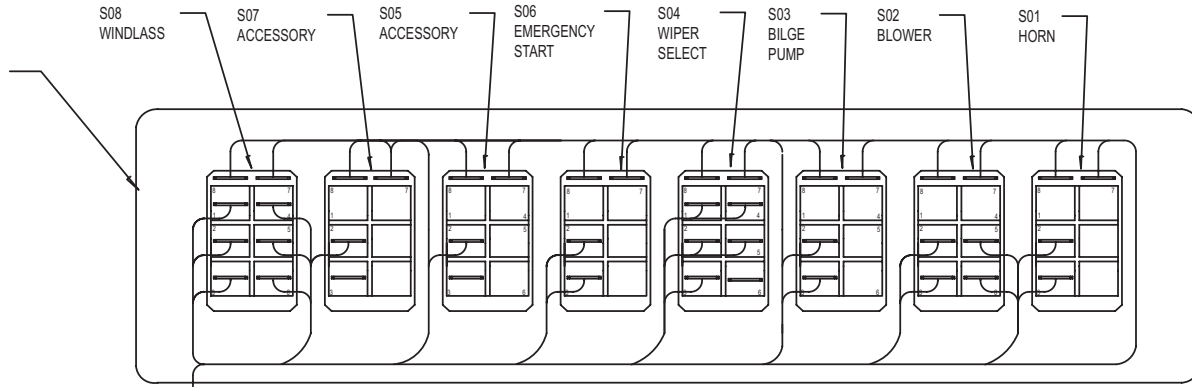

FOUR WINNS PARTS LIST

ITEM	PART NUMBER	QUANTITY	DESCRIPTION	FUNCTION	MANUFACTURER
-	028-0177	19	RECEPT,FASTON, 250,16-14	02	AMP
-	028-0179	15	RECEPT,FASTON, 250,12-10	07	AMP
-	028-0390	10	PIN,UMNL, 18-14	41	AMP
-	028-0454	19	SOCKET,UMNL, 18-14	42	AMP
-	025-3200	1	PANEL, BLANK PORT SWITCH		
J86	028-0443	1	RECEPT,UMNL, 9 CKT	STBD DECK	AMP
J116	028-0446	1	RECEPT,UMNL, 15 CKT	HELM BREAKER	AMP
P40	028-0451	1	PLUG,UMNL, 12 CKT	AFT SYSTEMS	AMP
S01	028-1896	1	SWITCH,SPST,(ON)-OFF,CONTURA V	HORN	CARLING
S02	028-1905	1	SWITCH,DPST,(ON)-OFF,CONTURA V	BLOWER	CARLING
S03	028-1897	1	SWITCH,SPST,(ON)-OFF,CONTURA V	BILGE PUMP	CARLING
S04	028-1904	1	SWITCH,DPST,(ON)-OFF-ON,CONTURA V	WIPER	CARLING
S05	028-1907	1	SWITCH,SPST,(ON)-OFF,CONTURA V	ACCESSORY	CARLING
S06	028-1959	1	SWITCH,SPST,(ON)-OFF,CONTURA V	EMERGENCY START	CARLING
S07	028-1907	1	SWITCH,SPST,(ON)-OFF,CONTURA V	ACCESSORY	CARLING
S08	028-1906	1	SWITCH,DPST (ON)-OFF-(ON),CONTURA V	WINDLASS	CARLING

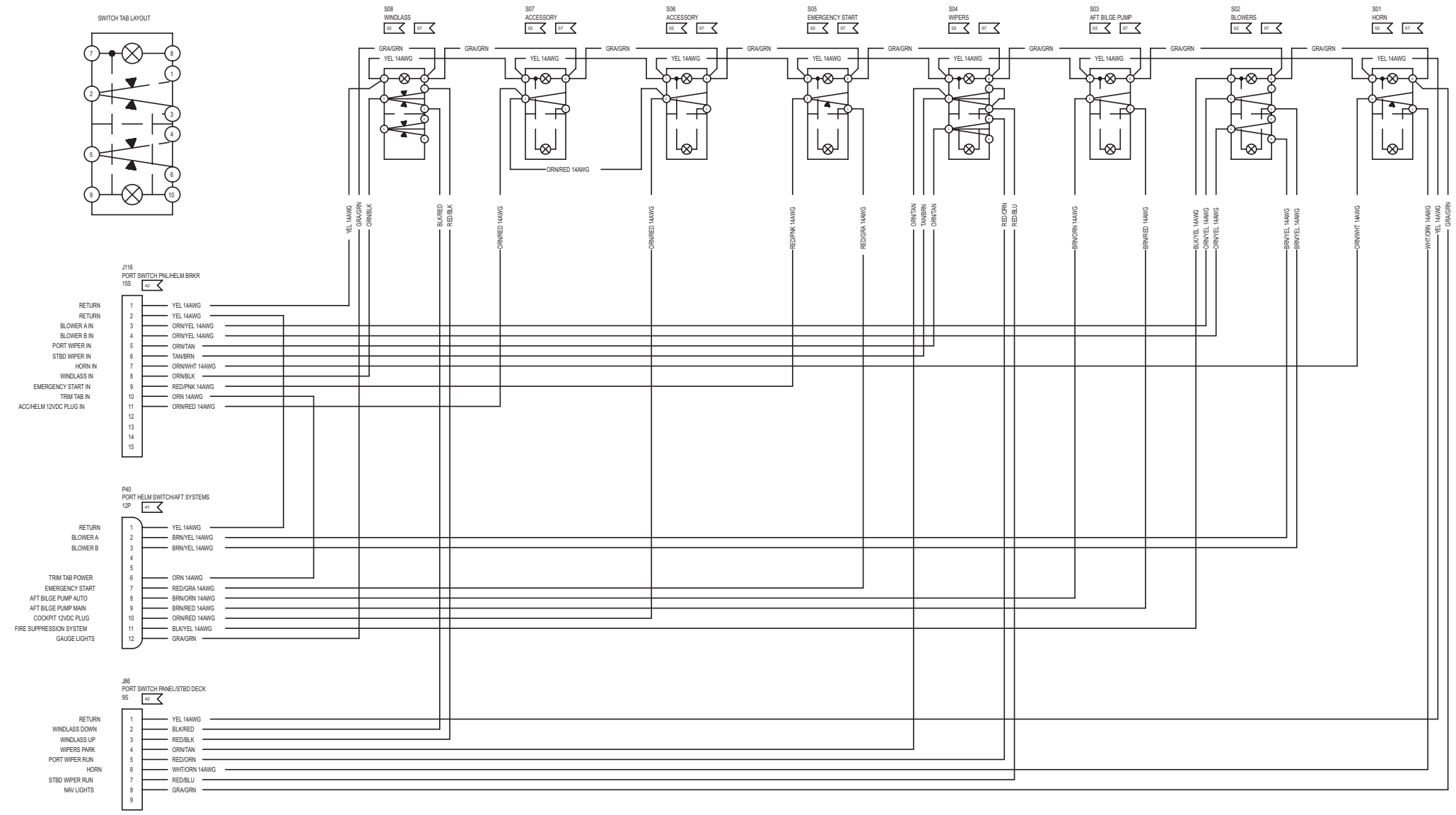
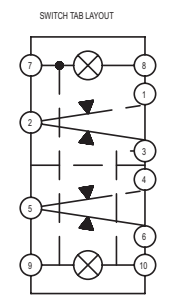
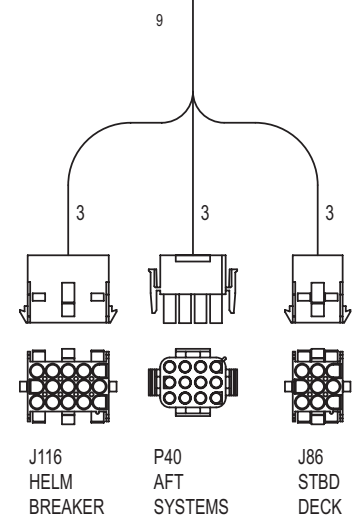

318 VISTA
PORT HELM SWITCH
PANEL ASSEMBLY

Owner's Manual Page 193

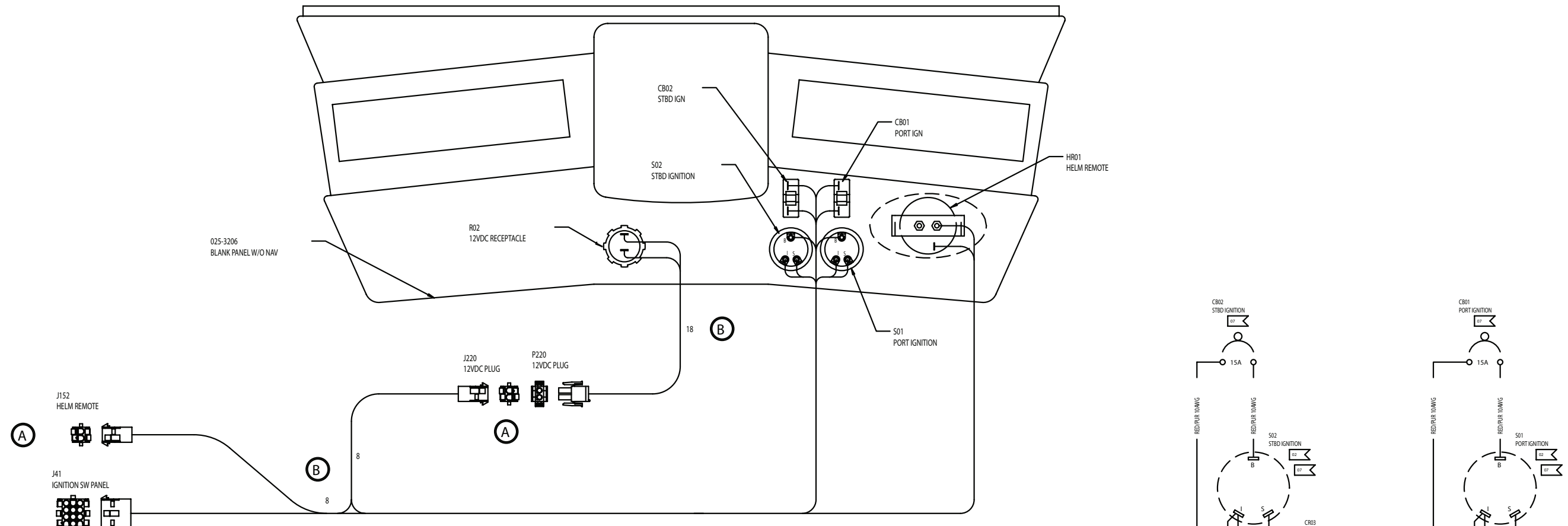

FOUR WINNS PARTS LIST

ITEM	PART NUMBER	QUANTITY	DESCRIPTION	FUNCTION	MANUFACTURER
-	028-0178	4	TERM, FASTON, 250, 16-14	02	AMP
-	028-0179	9	TERM, FASTON, 250, 12-10	07	AMP
-	028-0191	1	TERM, RING, PG, #10, 16-14	09	AMP
-	028-0454	10	SOCKET, UMNL, 18-14	42	AMP
-	028-0455	2	SOCKET, UMNL, 12-10	43	AMP
-	028-0390	2	PIN, UMNL, 18-14	41	AMP
-	-	3	PARALLEL SPLICE, NON INSUL 16-14	53	AMP
-	025-3206	1	PANEL BLANK, IGN, W/O NAV	IGN PANEL BLANK	-
J41	028-0445	1	RECEPT, UMNL, 12 CKT	IGN SW PANEL	AMP
J152	028-0441	1	RECEPT, UMNL, 2 CKT	HELM REMOTE	AMP
J220	028-0441	1	RECEPT, UMNL, 2 CKT	12VDC PLUG	AMP
P220	028-0447	1	PLUG, UMNL, 2 CKT	12VDC PLUG	AMP
S01	025-2000	1	SWITCH, IGNITION	PORT IGNITION	GENERAL
S02	025-2000	1	SWITCH, IGNITION	STBD IGNITION	GENERAL
CR03	025-0024-6	2	DIODE, DUAL	IGNITION BOTH	-
CB01	028-0467	1	BREAKER 15A	PORT IGNITION	MP
CB02	028-0467	1	BREAKER 15A	STBD IGNITION	MP
R02	028-1100	1	RECEPT, 12V AFI	12V RECEPTACLE	AFI
HR01	-	REF	STEREO REMOTE	STEREO REMOTE	CLARION

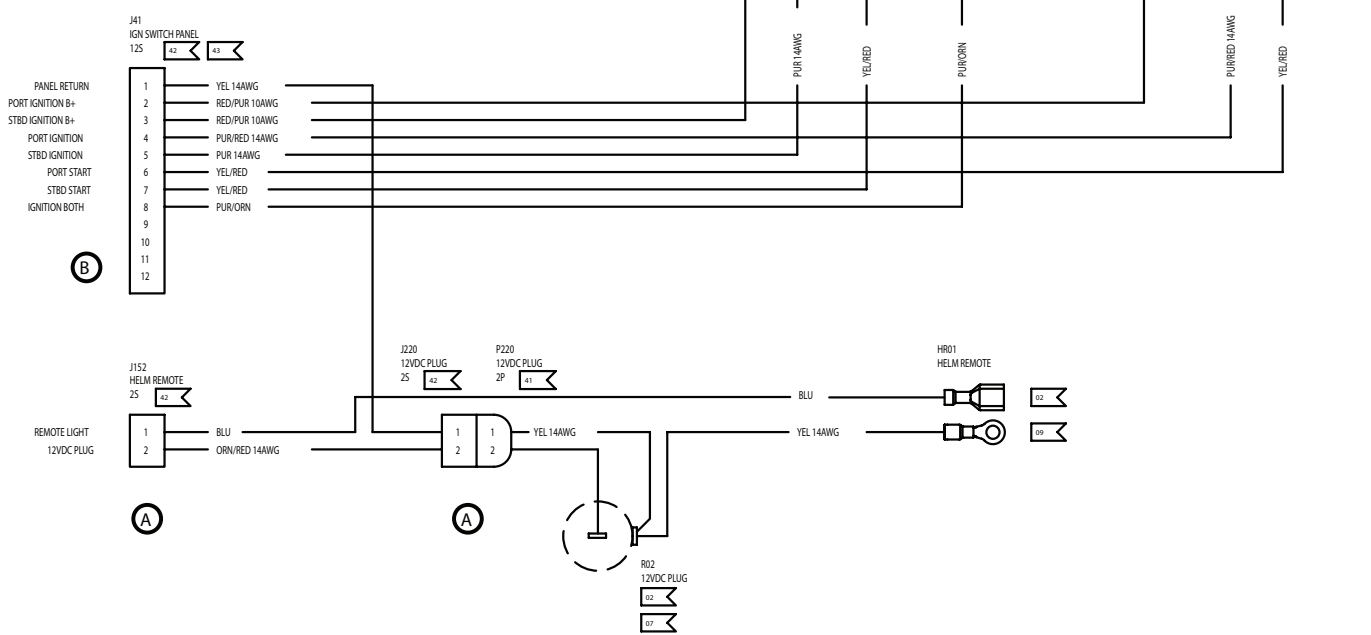

**318 VISTA
IGNITION W/OUT NAV. PKG.
PANEL ASSEMBLY**

Owner's Manual Page 194

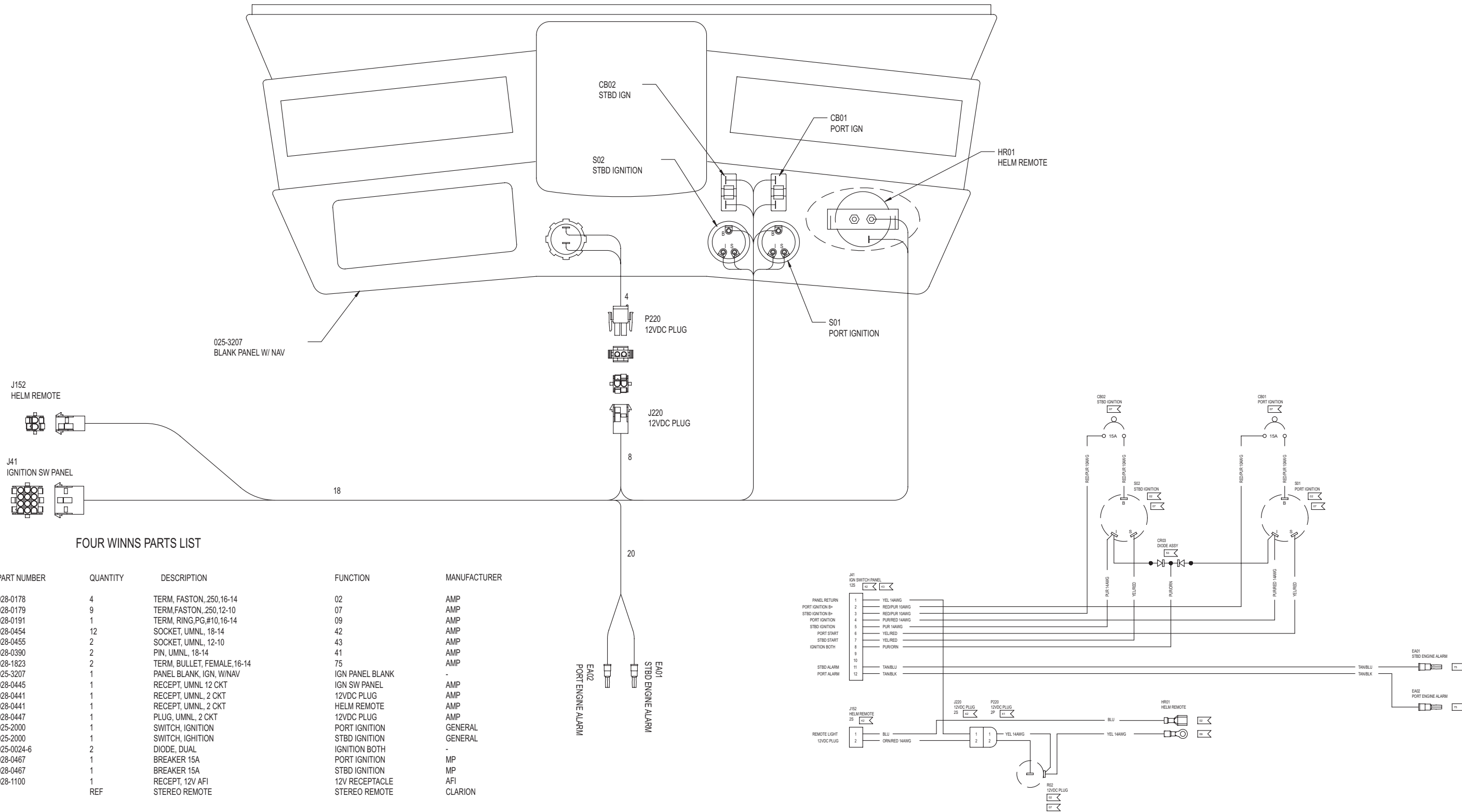

**318 VISTA
IGNITION W/NAV. PKG.
PANEL ASSEMBLY**

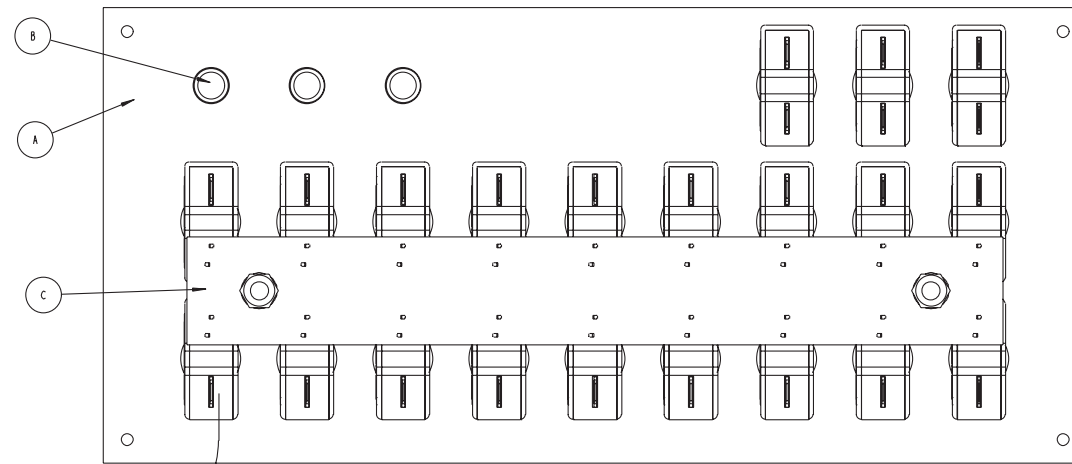
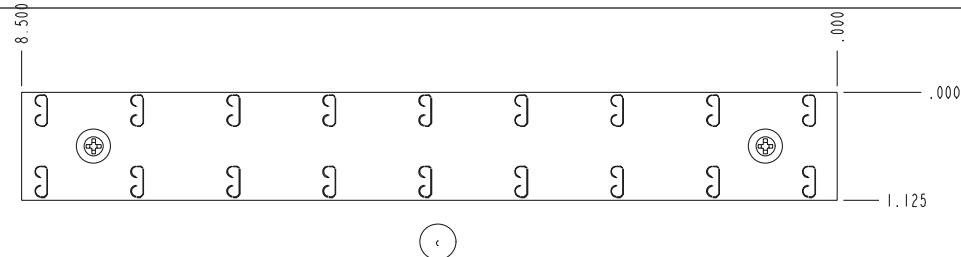

P123
PORT SW FUNC/HELM BRKR

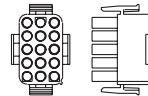

6

P112
HELM BRKR/AFT SYS

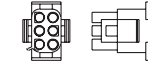

6

J124
STBD SW FUNC/HELM BRKR

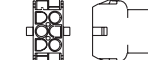

6

6

24

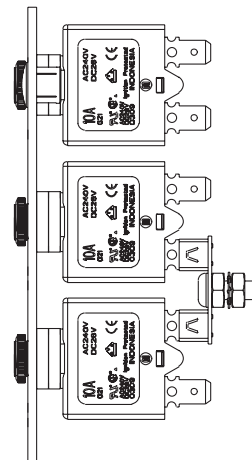
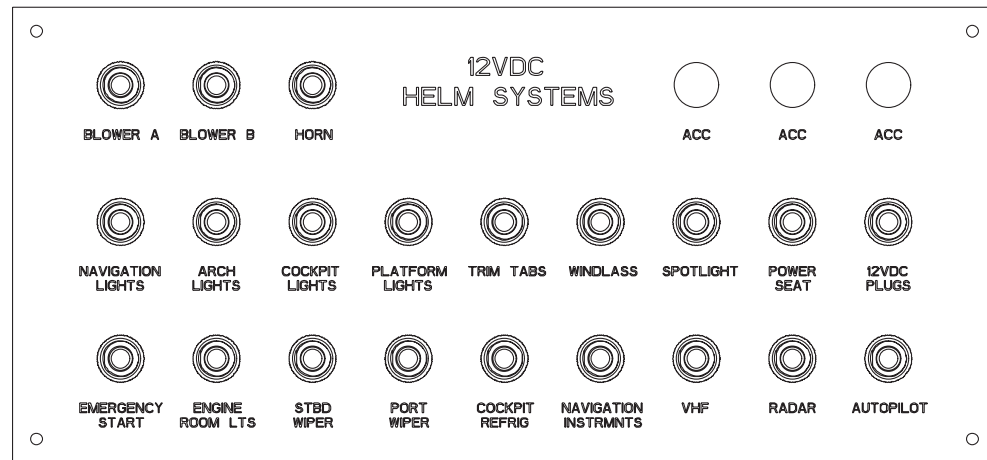

- 1 BLOWER A IN
 - 2 BLOWER B IN
 - 3 PORT WIPER IN
 - 4 STBD WIPER IN
 - 5 HORN IN
 - 6 WINDLASS IN
 - 7 EMERGENCY START IN
 - 8 TRIM TABS IN
 - 9 ACC/HELM 12VDC PLUG IN
 - 10
 - 11
 - 12 SPOTLIGHT VHF
 - 13 RADAR
 - 14 NAV INSTRUMENTS
 - 15
- 1 POWER SEAT IN
 - 2 ACC IN
 - 3 ENGINE HATCH/LTS IN
 - 4 ARCH LTS IN
 - 5 NAV LTS IN
 - 6 PLATFORM LTS IN
- 1 COCKPIT FRIG IN
 - 2 COCKPIT 12VDC PLUG IN
 - 3 BLOWER A IN
 - 4 BLOWER B IN
 - 5 COCKPIT LTS IN
 - 6 AUTOPILOT IN

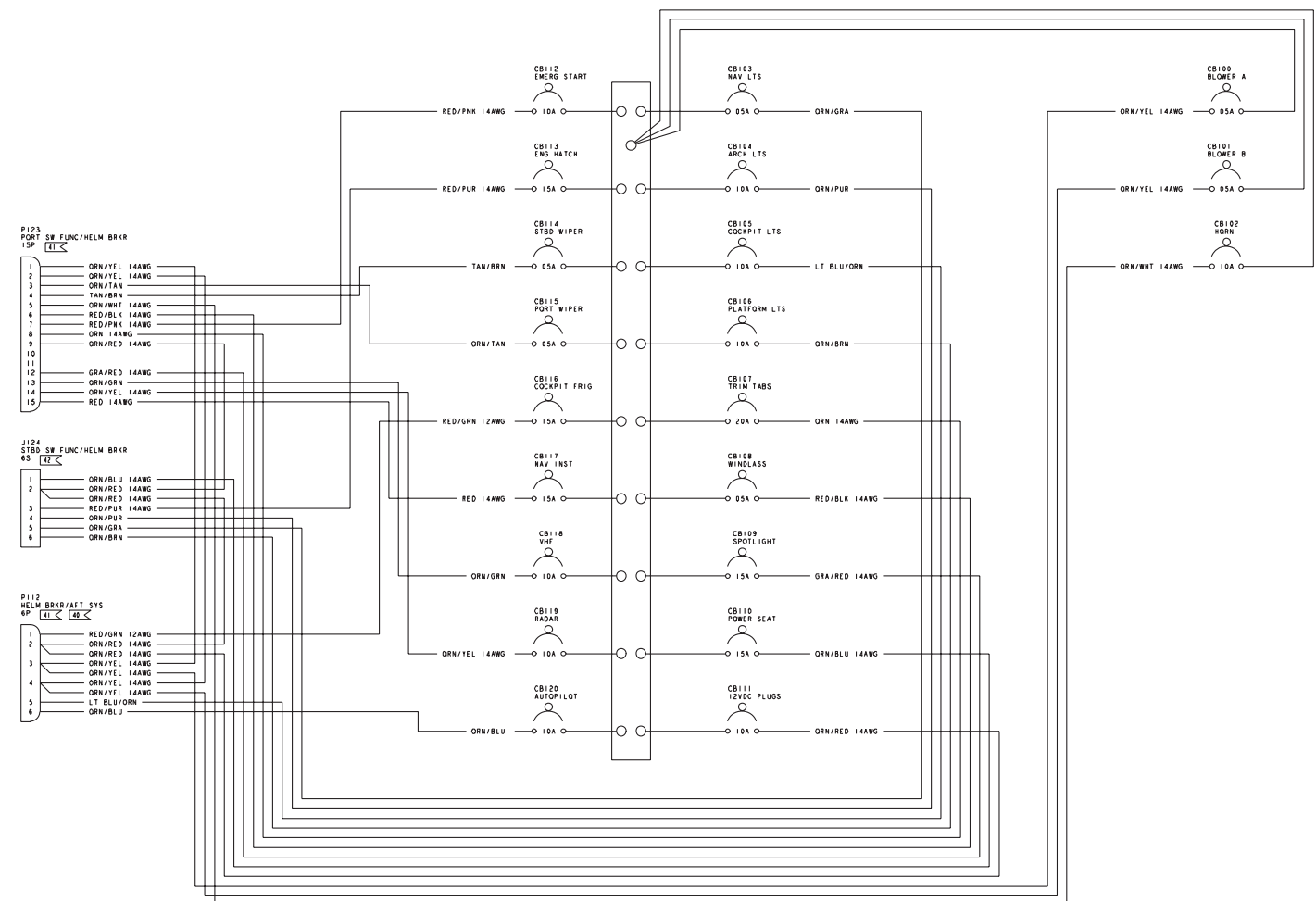

ITEM	FW P/N	QUANTITY	DESCRIPTION	FUNCTION	MANUFACTURER
A	025-3363	1	PANEL, BLANK, HELM BREAKER, 318-378V	-	PORTAGE WIRE
B	028-0151	3	PLUG, DOME, .315	-	HEYCO DP375BLACK
C	-	1	BREAKER BUSS, FASTON, 18 POSITION	-	PORTAGE WIRE
-	028-0156	24	RECEPTACLE, FLAG, UF, .250, 16-14AWG	101	AMP 3-520132-2
-	028-0454	6	SOCKET, UMNL, 18-14AWG	42	AMP 350919-3
-	028-0390	18	PIN, UMNL, 18-14AWG	41	AMP 350918-3
-	028-0453	1	PIN, UMNL, 12-10AWG	40	AMP 640309-3
CB100	028-1879	1	BREAKER, CKT, 1GN PROTECTED, 5A	BLOWER A	ETA 165862102P105A
CB101	028-1879	1	BREAKER, CKT, 1GN PROTECTED, 5A	BLOWER B	ETA 165862102P105A
CB102	028-1880	1	BREAKER, CKT, 1GN PROTECTED, 10A	HORN	ETA 165862102P1010A
CB103	028-1879	1	BREAKER, CKT, 1GN PROTECTED, 5A	NAV LIGHTS	ETA 165862102P105A
CB104	028-1880	1	BREAKER, CKT, 1GN PROTECTED, 10A	ARCH LIGHTS	ETA 165862102P1010A
CB105	028-1880	1	BREAKER, CKT, 1GN PROTECTED, 10A	COCKPIT LIGHTS	ETA 165862102P1010A
CB106	028-1880	1	BREAKER, CKT, 1GN PROTECTED, 10A	PLATFORM LIGHTS	ETA 165862102P1010A
CB107	028-1881	1	BREAKER, CKT, 1GN PROTECTED, 20A	TRIM TABS	ETA 165862102P1020A
CB108	028-1879	1	BREAKER, CKT, 1GN PROTECTED, 5A	WINDLASS	ETA 165862102P105A
CB109	028-2024	1	BREAKER, CKT, 1GN PROTECTED, 15A	SPOTLIGHT	ETA 165862102P1015A
CB110	028-2024	1	BREAKER, CKT, 1GN PROTECTED, 15A	POWER SEAT	ETA 165862102P1015A
CB111	028-1880	1	BREAKER, CKT, 1GN PROTECTED, 10A	12VDC PLUGS	ETA 165862102P1010A
CB112	028-1880	1	BREAKER, CKT, 1GN PROTECTED, 10A	EMERGENCY START	ETA 165862102P1010A
CB113	028-2024	1	BREAKER, CKT, 1GN PROTECTED, 15A	ENGINE HATCH/LIGHTS	ETA 165862102P1015A
CB114	028-1879	1	BREAKER, CKT, 1GN PROTECTED, 5A	STBD WIPER	ETA 165862102P105A
CB115	028-1879	1	BREAKER, CKT, 1GN PROTECTED, 5A	PORT WIPER	ETA 165862102P105A
CB116	028-2024	1	BREAKER, CKT, 1GN PROTECTED, 15A	COCKPIT REFRIGERATOR	ETA 165862102P1015A
CB117	028-2024	1	BREAKER, CKT, 1GN PROTECTED, 15A	NAV INSTRUMENTS	ETA 165862102P1015A
CB118	028-1880	1	BREAKER, CKT, 1GN PROTECTED, 10A	VHF	ETA 165862102P1010A
CB119	028-1880	1	BREAKER, CKT, 1GN PROTECTED, 10A	RADAR	ETA 165862102P1010A
CB120	028-1880	1	BREAKER, CKT, 1GN PROTECTED, 10A	AUTOPILOT	ETA 165862102P1010A
J124	028-1399	1	RECEPT, UMNL, 6 CKT	STBD SW FUNC/HELM BRKR	AMP 926301-1
P112	028-0389	1	PLUG, UMNL, 6 CKT	HELM BRKR/AFT SYSTEMS	AMP 640585-1
P123	028-0452	1	PLUG, UMNL, 15 CKT	PORT SW FUNC/HELM BRKR	AMP 11-480710-0

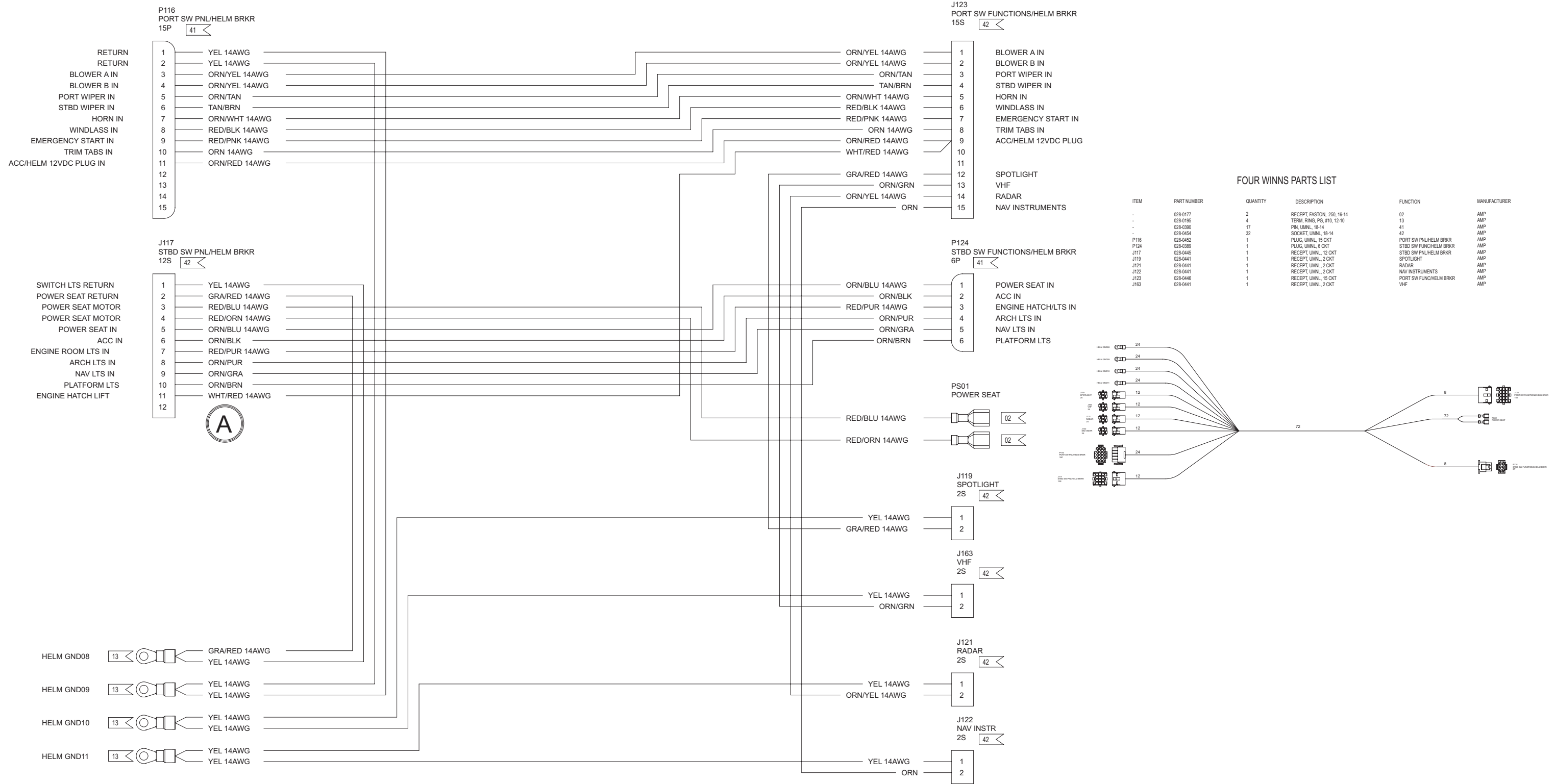

FOUR WINNS PARTS LIST

ITEM	PART NUMBER	QUANTITY	DESCRIPTION	FUNCTION	MANUFACTURER
-	028-0177	2	RECEPT FASTON, 250, 16-14	02	AMP
-	028-0195	4	TERM. RING, PG. #10, 12-10	13	AMP
-	028-0390	17	PNL, UMNL, 16-14	41	AMP
-	028-0454	32	SOCKET, UMNL, 16-14	42	AMP
P116	028-0452	1	PLUG, UMNL, 15 CKT	PORT SW PNL/HELM BRKR	AMP
P124	028-0393	1	PLUG, UMNL, 6 CKT	STBD SW PNL/HELM BRKR	AMP
J117	028-0445	1	RECEPT, UMNL, 12 CKT	STBD SW PNL/HELM BRKR	AMP
J119	028-0441	1	RECEPT, UMNL, 2 CKT	SPOTLIGHT	AMP
J121	028-0441	1	RECEPT, UMNL, 2 CKT	RADAR	AMP
J122	028-0441	1	RECEPT, UMNL, 2 CKT	NAV INSTRUMENTS	AMP
J123	028-0446	1	RECEPT, UMNL, 15 CKT	PORT SW PNL/HELM BRKR	AMP
J163	028-0441	1	RECEPT, UMNL, 2 CKT	VHF	AMP

**318 VISTA
HELM BREAKER
HARNESS ASSEMBLY**

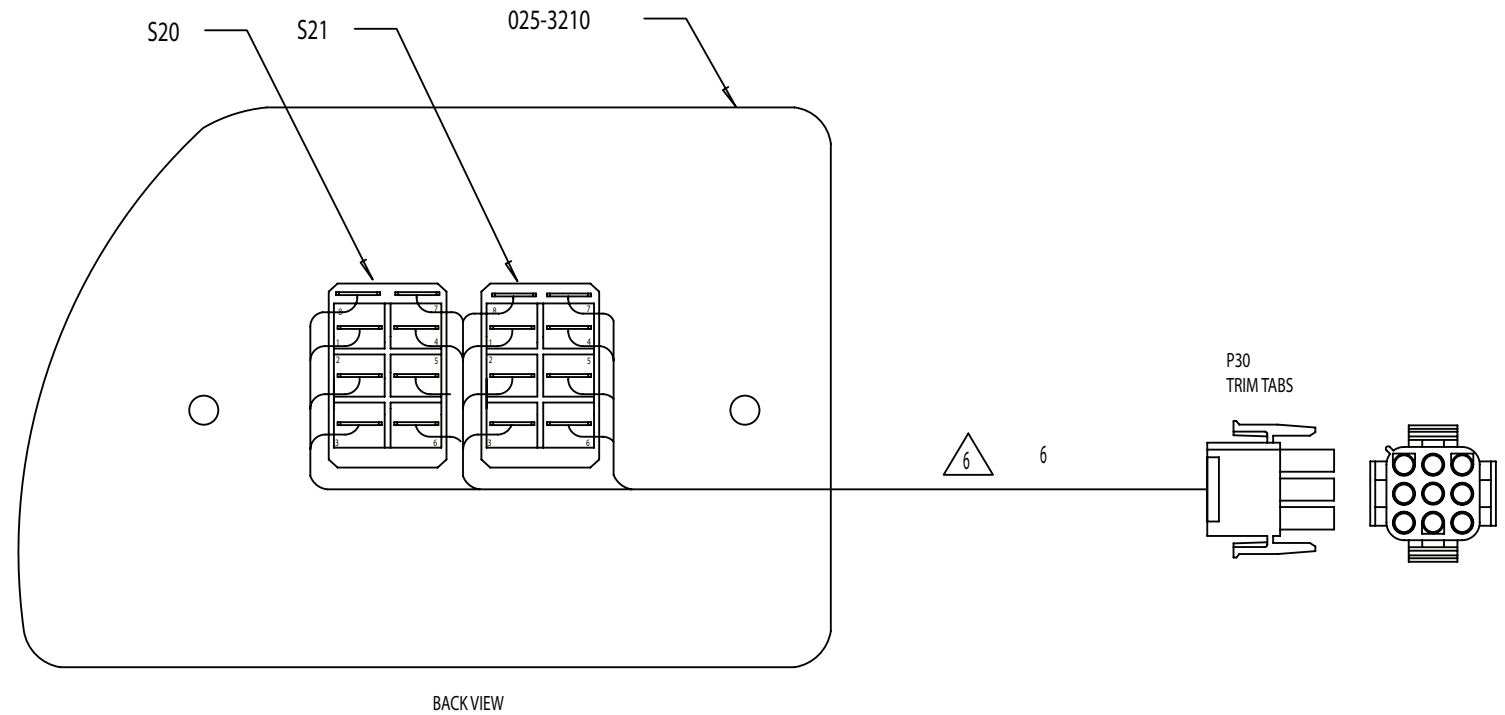
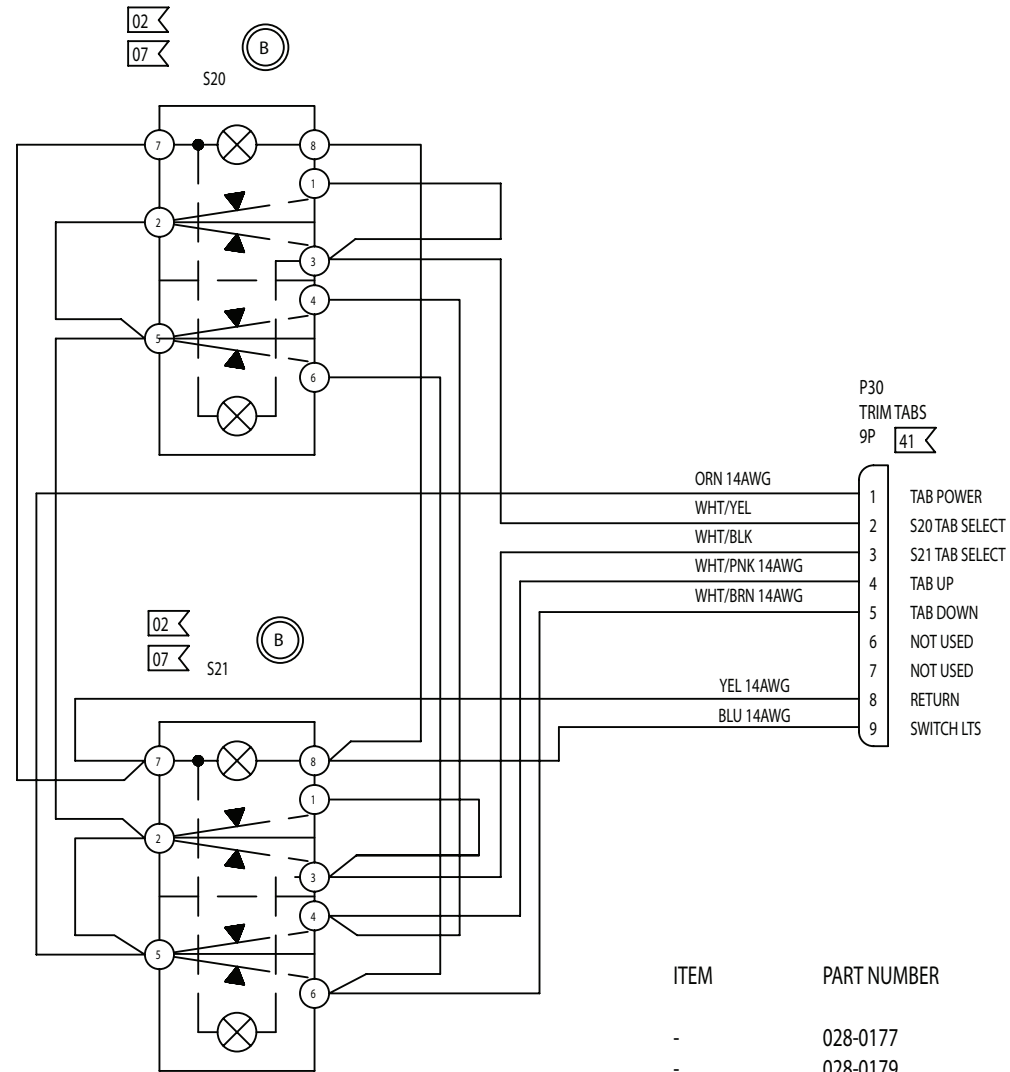
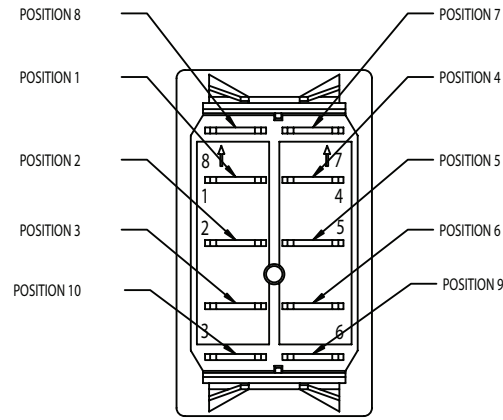

FOUR WINNS PARTS LIST

ITEM	PART NUMBER	QUANTITY	DESCRIPTION	FUNCTION	MANUFACTURER
-	028-0177	7	TERM,FASTON,250,18-14	02	AMP
-	028-0179	9	TERM,FASTON,250,12-10	07	AMP
-	028-0390	7	PIN,UMNL,18-14	41	AMP
-	025-3210	1	PANEL,BLANK,TRIM TABS 308/348 '05	-	-
P30	028-0449	1	PLUG,UMNL,9 CKT	TRIM TABS	AMP
S20	028-1902	1	SWITCH,(ON) OFF (ON) CONT V	TAB SELECT	CARL SW
S21	028-1902	1	SWITCH,(ON) OFF (ON) CONT V	TAB SELECT	CARL SW

318 VISTA TRIM TABS PANEL ASSEMBLY

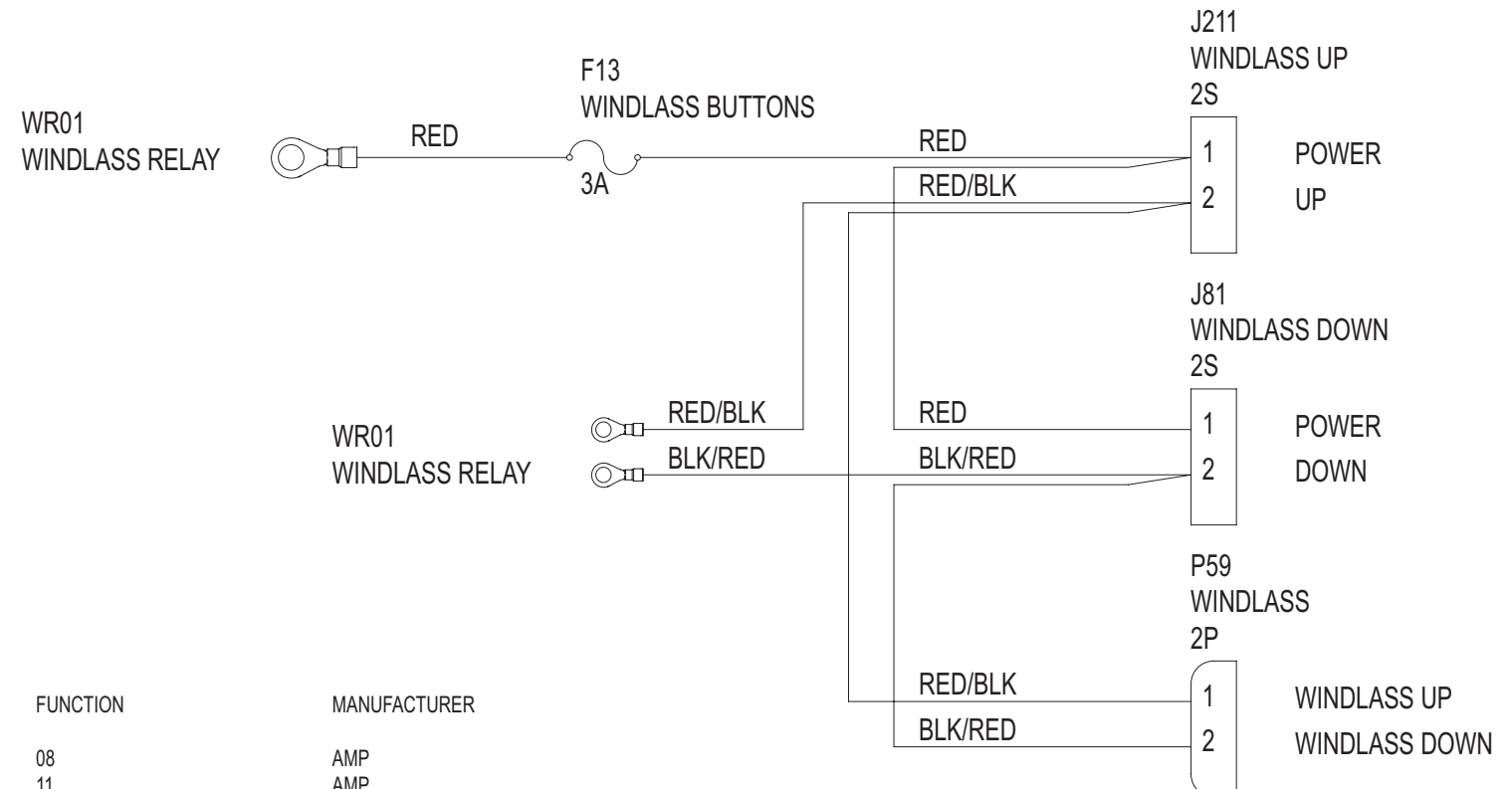
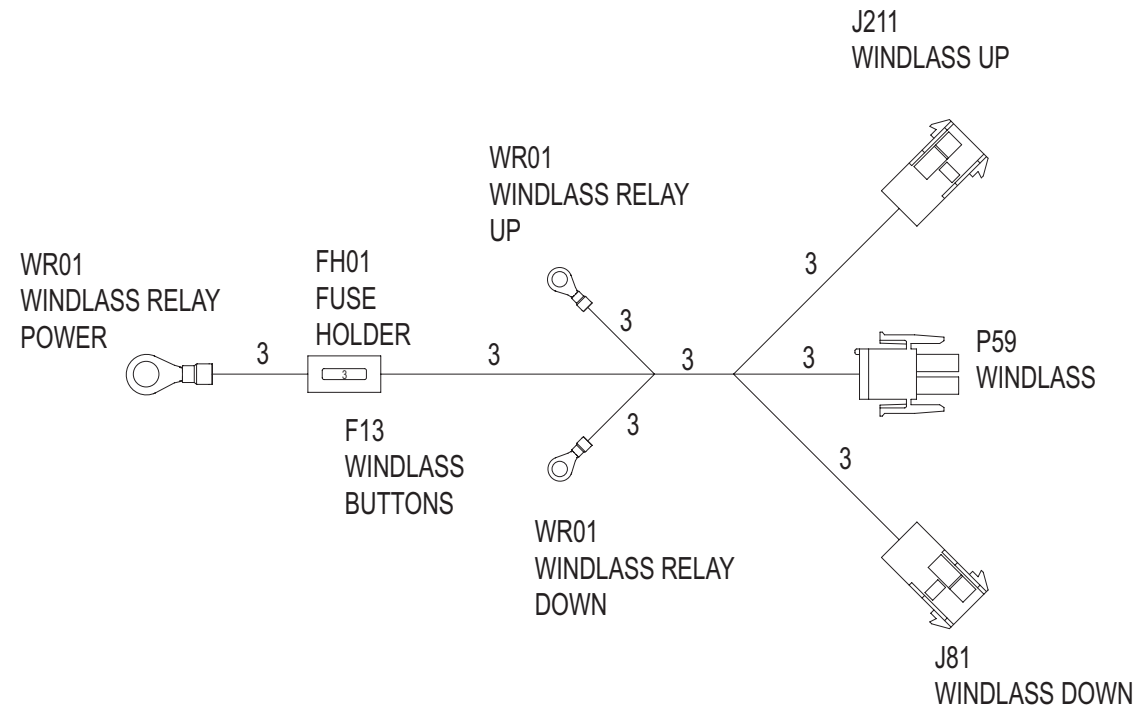

FOUR WINNS PARTS LIST

ITEM	PART NUMBER	QUANTITY	DESCRIPTION	FUNCTION	MANUFACTURER
	028-0189	2	TERM,RING,#8,16-14	08	AMP
	028-0193	1	TERM,RING,3/8,.250	11	AMP
	028-0390	2	PIN,UMNL,18-14	41	AMP
	028-0454	4	SOCKET,UMNL,18-14	42	AMP
	028-0506	1	FUSE,ATC,3A	WINDLASS BUTTON	BUSS
F13		1	FUSE HOLDER,INLINE	FUSE HOLDER	3M
FH01	028-0441	1	RECEPT,UMNL,2 CKT	WINDLASS DOWN	AMP
J81	028-0441	1	RECEPT,UMNL,2 CKT	WINDLASS UP	AMP
J211	028-0447	1	PLUG,UMNL,2 CKT	WINDLASS	AMP
P59	065-0842-02	REF	WINDLASS RELAY	WINDLASS RELAY	
WR01					

FOUR WINNS WIRE LIST

COLOR	GA	FIRST	PIN	TERM	NOTE	SECOND	PIN	TERM	NOTE	FUNCTION
RED	16	WR01	+	11		FH01	LINE	51		BUTTON POWER
RED	16	FH01	LOAD	51		J80	1	42	SA	BUTTON POWER
RED	16	J80	1	42	SA	J81	1	42		BUTTON POWER
RED/BLK	16	WR01	UP	08		J80	2	42	SB	WINDLASS UP
RED/BLK	16	J80	2	42	SB	P59	1	41		WINDLASS UP
BLK/RED	16	WR01	DOWN	08		J81	2	42	SC	WINDLASS DOWN
BLK/RED	16	J81	2	42	SC	P59	2	41		WINDLASS DOWN

This diagram shows the wiring for the windlass pedal (P81). It details the connections between the pedal and connectors P81 (WINDLASS PEDAL 2P) and P59 (WINDLASS 2P). Wire colors are specified as BLK/RED and RED.

ITEM	PART NUMBER	QUANTITY	DESCRIPTION	FUNCTION	MANUFACTURER
	028-0193	2	TERM,RING,3/8,16-14	11	AMP
	028-0390	2	PIN,UMNL,18-14	41	AMP
FP01		REF	FOOT PEDAL,MAXWELL	FOOT PEDAL	
P81	028-0447	1	PLUG,UMNL,2 CKT	WINDLASS PEDAL	AMP

COLOR	GA	FIRST	PIN	TERM	NOTE	SECOND	PIN	TERM	NOTE	FUNCTION
BLK/RED	16	FP01	-	10	BA	P81	1	41		WINDLASS PEDAL RET
RED	16	FP01	+	10	BA	P81	2	41		WINDLASS PEDAL POWER

318 VISTA MAXWELL WINDLASS OPTION RELAY & FOOT PEDAL HARNESS ASSEMBLY

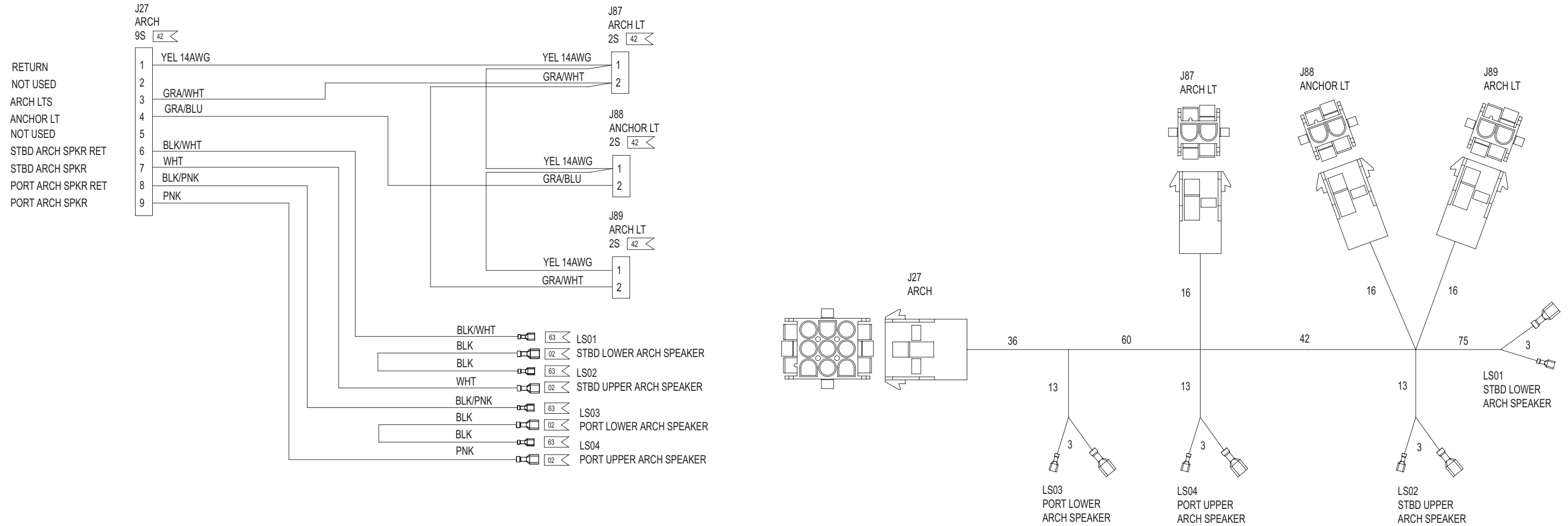

FOUR WINNS PARTS LIST

ITEM	PART NUMBER	QUANTITY	DESCRIPTION	FUNCTION	MANUFACTURER
-	028-0177	4	TERM,FASTON,.250,16-14	02	AMP
-	028-0454	13	SOCKET,UMNL,18-14	42	AMP
-	028-1288	4	TERM,FASTON,.205,18-14	63	AMP
J27	028-0443	1	RECEPT,UMNL,9 CKT	ARCH	AMP
J87	028-0441	1	RECEPT,UMNL,2 CKT	ARCH LT	AMP
J88	028-0441	1	RECEPT,UMNL,2 CKT	ANCHOR LT	AMP
J89	028-0441	1	RECEPT,UMNL,2 CKT	ARCH LT	AMP
LS01	-	REF	SPEAKER	STBD LOWER	-
LS02	-	REF	SPEAKER	STBD UPPER	-
LS03	-	REF	SPEAKER	PORT LOWER	-
LS04	-	REF	SPEAKER	PORT UPPER	-

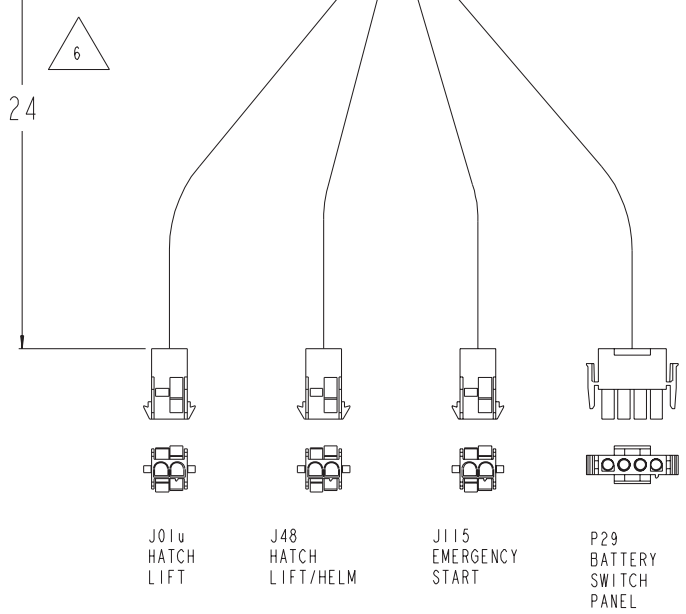
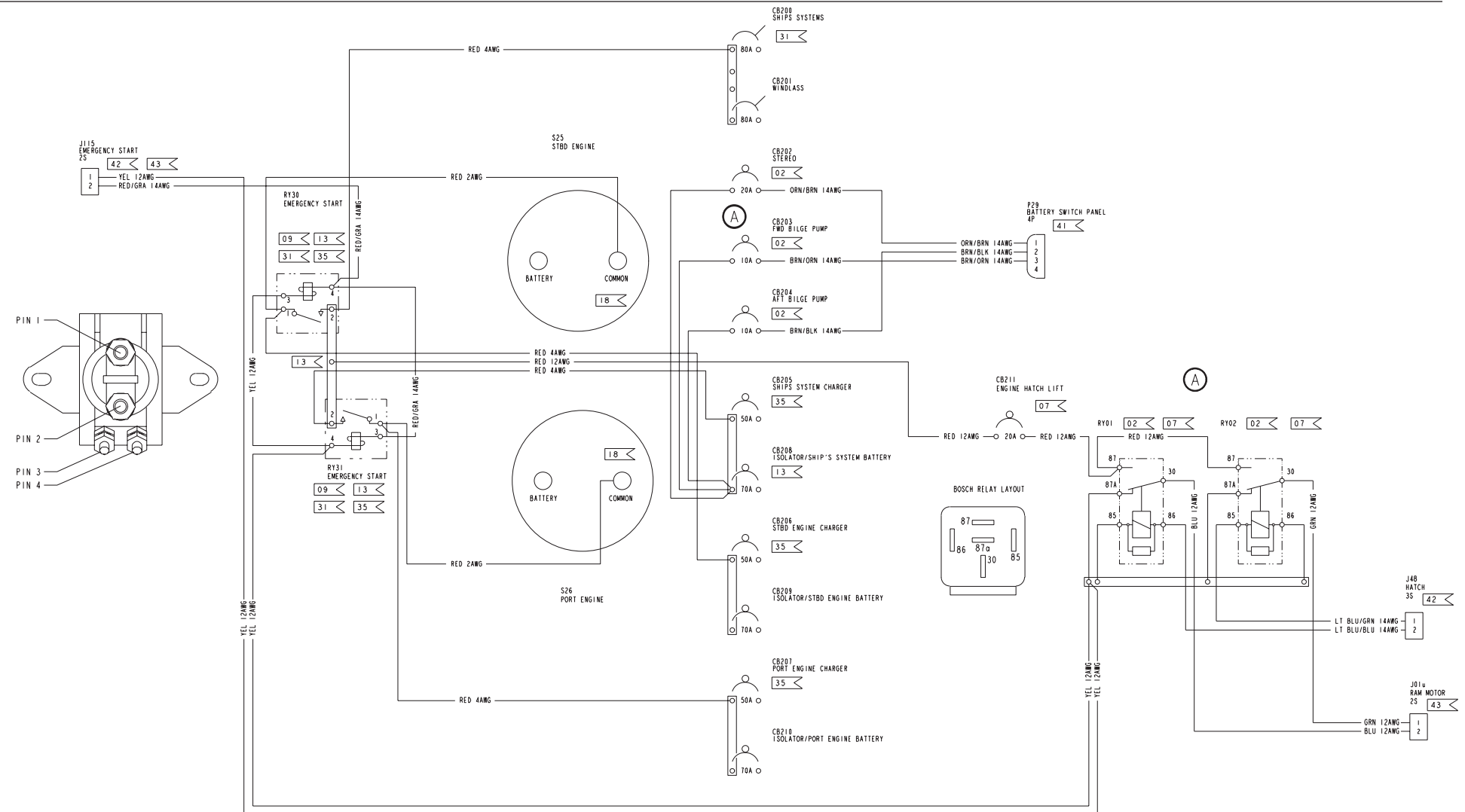
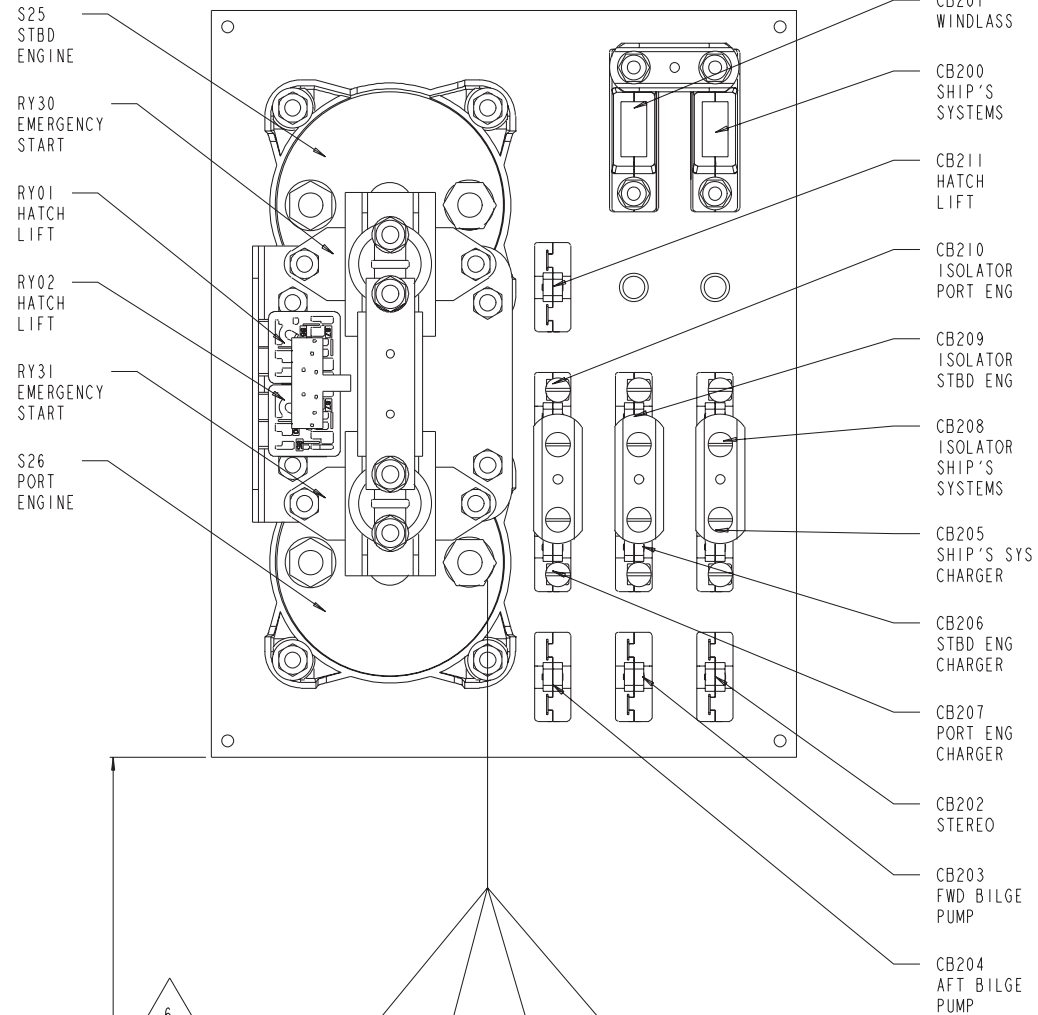

FOUR WINNS PARTS LIST

ITEM	PART NUMBER	QUANTITY	DESCRIPTION	CODE	MANUFACTURER
-	028-0177	8	RECEPTACLE, FASTON, .250, 18-14	02	AMP
-	028-0179	7	RECEPTACLE, FASTON, .250, 12-10	07	AMP
-	028-0191	2	TERM. RING, #10, 16-14	09	AMP
-	028-0195	3	TERM. RING, #10, 12-10	13	AMP
-	028-1988	3	TERM. RING, #10, 4	34	AMP
-	028-1929	3	TERM. RING, 1/4, 4	35	AMP
-	028-0399	2	TERM. RING, 3/8, 2	18	AMP
-	028-1930	4	TERM. RING, 1/4, 2	31	AMP
-	028-0390	3	PIN, UMNL, 18-14	41	AMP
-	028-0454	3	SOCKET, UMNL, 18-14	42	AMP
-	028-0455	3	SOCKET, UMNL, 12-10	43	AMP
J01u	028-0441	1	RECEPT, UMNL, 2 CKT	HATCH LIFT	AMP
J48	028-0441	1	RECEPT, UMNL, 2 CKT	LIFT RELAY	AMP
J115	028-0441	1	RECEPT, UMNL, 2 CKT	EMERGENCY START	AMP
P29	028-0448	1	PLUG, UMNL, 4 CKT	AUTO FUNCTIONS	AMP
-	025-3372	1	PANEL, BLANK, BATTERY SWITCH		AMP
CB200	028-1888	1	BREAKER, 80A	SHIP'S SYSTEMS	CARLINGSWITCH
CB201	028-1888	1	BREAKER, 80A	WINDLASS	CARLINGSWITCH
CB202	028-0397	1	BREAKER, 20A	STEREO	MECH PROD
CB203	028-0396	1	BREAKER, 10A	FWD BILGE PUMP	MECH PROD
CB204	028-0396	1	BREAKER, 10A	AFT BILGE PUMP	MECH PROD
CB205	028-2032	1	BREAKER, 50A	SS CHARGER	MECH PROD
CB206	028-2032	1	BREAKER, 50A	STBD ENG CHARGER	MECH PROD
CB207	028-2032	1	BREAKER, 50A	PORT ENG CHARGER	MECH PROD
CB208	028-2033	1	BREAKER, 70A	SYS ISOLATOR	MECH PROD
CB209	028-2033	1	BREAKER, 70A	STBD ENG ISOLATOR	MECH PROD
CB210	028-2033	1	BREAKER, 70A	PORT ENG ISOLATOR	MECH PROD
CB211	028-0397	1	BREAKER, 20A	HATCH LIFT	MECH PROD
S25	028-1912	1	SWITCH, BATTERY ON/OFF	STBD ENG SWITCH	BLUE SEA
S26	028-1912	1	SWITCH, BATTERY ON/OFF	PORT ENG SWITCH	BLUE SEA
RY01	028-1915	1	RELAY, SPDT BOSCH 5-TERMINAL	HATCH LIFT RELAY	BOSCH
RY02	028-1915	1	RELAY, SPDT BOSCH 5-TERMINAL	HATCH LIFT RELAY	BOSCH
RY30	028-1753	1	RELAY, BATTERY SWITCH PANEL	EMERGENCY START	SIERRA
RY31	028-1753	1	RELAY, BATTERY SWITCH PANEL	EMERGENCY START	SIERRA

FRONT VIEW

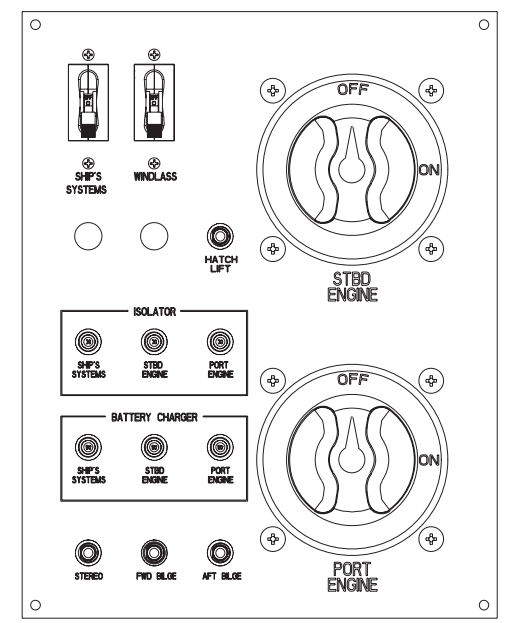

318 VISTA BATTERY SWITCH PANEL ASSEMBLY

Owner's Manual Page 201

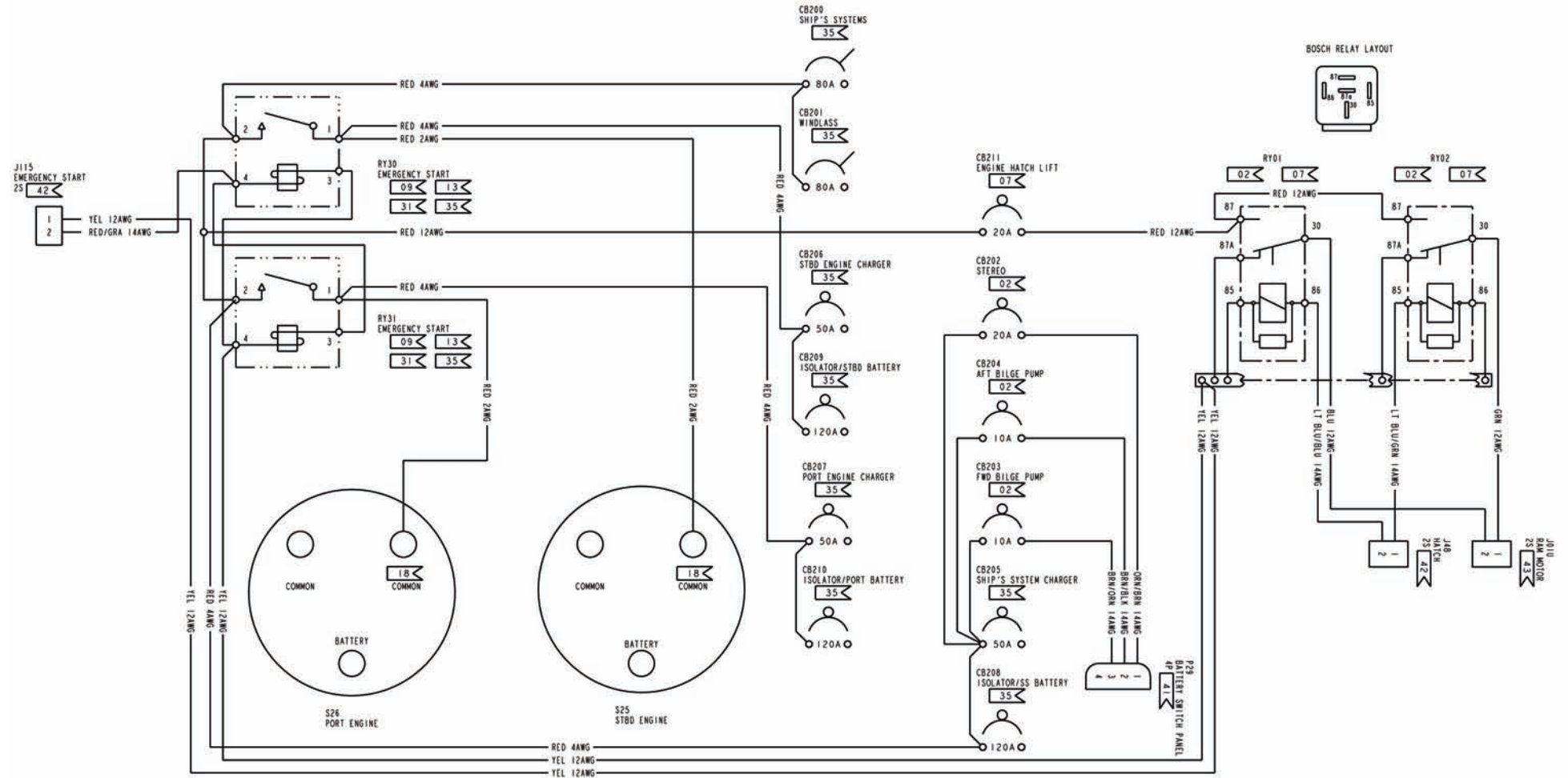
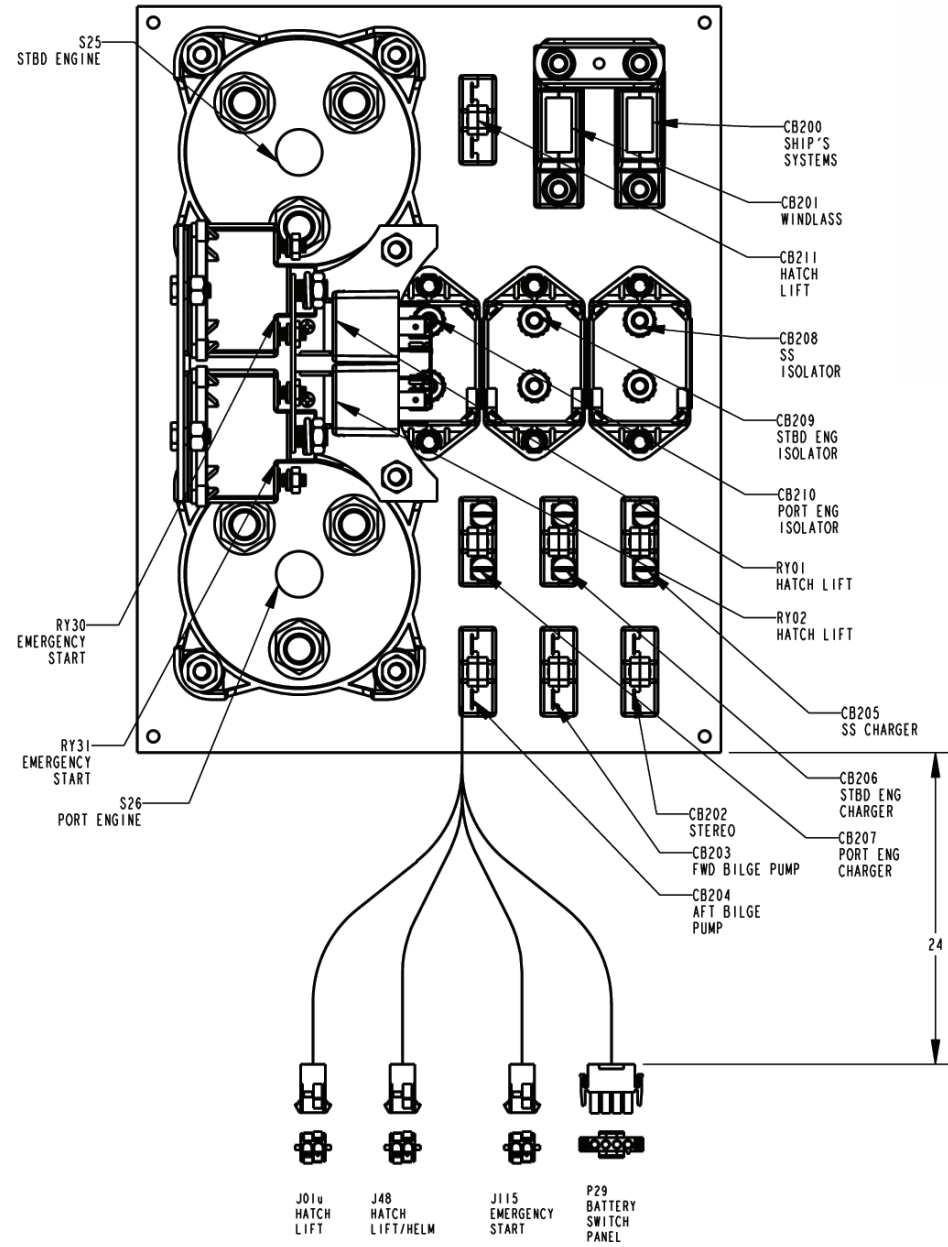
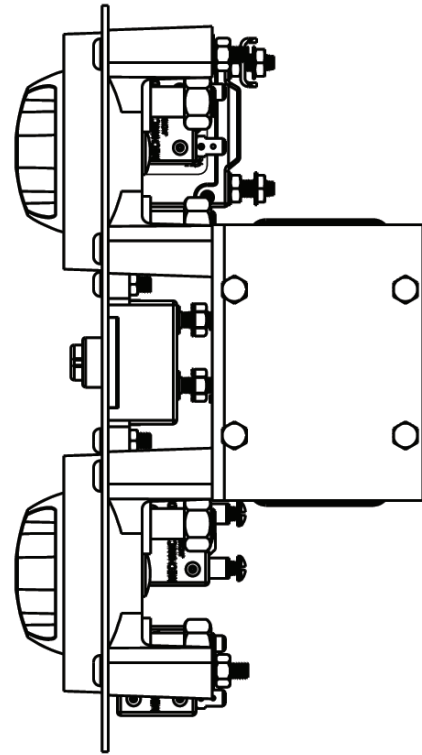
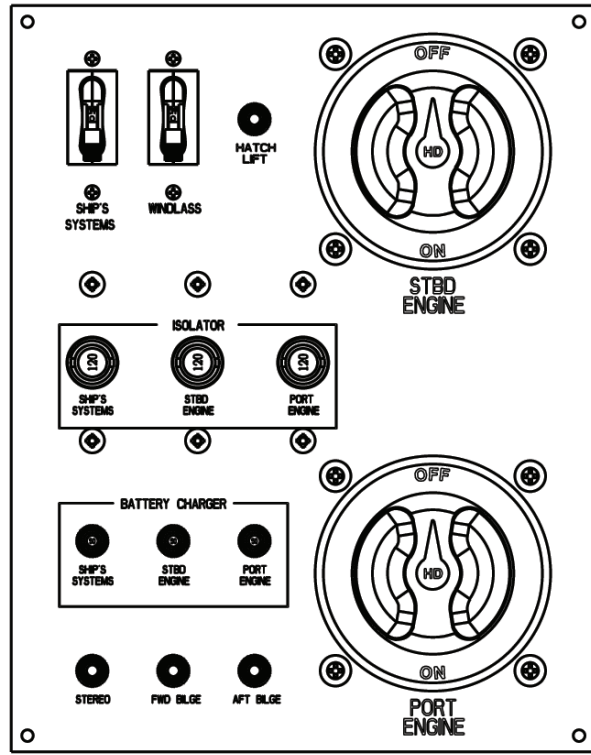

FOUR WINNS PARTS LIST

ITEM	PART NUMBER	QUANTITY	DESCRIPTION	CODE	MANUFACTURER
-	028-0177	8	RECEPTACLE, FASTON, .250, 18-14	02	AMP
-	028-0179	7	RECEPTACLE, FASTON, .250, 12-10	07	AMP
-	028-0191	2	TERM. RING, #10, 16-14	09	AMP
-	028-0195	3	TERM. RING, #10, 12-10	13	AMP
-	028-1988	3	TERM. RING, #10, 4	34	AMP
-	028-1929	3	TERM. RING, 1/4, 4	35	AMP
-	028-0399	2	TERM. RING, 3/8, 2	18	AMP
-	028-1930	4	TERM. RING, 1/4, 2	31	AMP
-	028-0390	3	PIN, UMNL, 18-14	41	AMP
-	028-0454	3	SOCKET, UMNL, 18-14	42	AMP
-	028-0455	3	SOCKET, UMNL, 12-10	43	AMP
J01U	028-0441	1	RECEPT, UMNL, 2 CKT		HATCH LIFT
J48	028-0441	1	RECEPT, UMNL, 2 CKT		LIFT RELAY
J115	028-0441	1	RECEPT, UMNL, 2 CKT		EMERGENCY START
P29	028-0448	1	PLUG, UMNL, 4 CKT		AUTO FUNCTIONS
-	025-3480	1	PANEL, BLANK, DIESEL BATT SWT		
CB200	028-1888	1	BREAKER, 80A		SHIP'S SYSTEMS
CB201	028-1888	1	BREAKER, 80A		WINDLASS
CB202	028-0397	1	BREAKER, 20A		STEREO
CB203	028-0396	1	BREAKER, 10A		FWD BILGE PUMP
CB204	028-0396	1	BREAKER, 10A		AFT BILGE PUMP
CB205	028-2032	1	BREAKER, 50A		SS CHARGER
CB206	028-2032	1	BREAKER, 50A		STBD ENG CHARGER
CB207	028-2032	1	BREAKER, 50A		PORT ENG CHARGER
CB208	028-2066	1	BREAKER, 120A		SYS ISOLATOR
CB209	028-2066	1	BREAKER, 120A		STBD ENG ISOLATOR
CB210	028-2066	1	BREAKER, 120A		PORT ENG ISOLATOR
CB211	028-0397	1	BREAKER, 20A		HATCH LIFT
S25	028-2012	1	SWITCH, BATTERY HD, ON/OFF		STBD ENG SWITCH
S26	028-2012	1	SWITCH, BATTERY HD, ON/OFF		PORT ENG SWITCH
RY01	028-1915	1	RELAY, SPDT BOSCH 5-TERMINAL		HATCH LIFT RELAY
RY02	028-1915	1	RELAY, SPDT BOSCH 5-TERMINAL		HATCH LIFT RELAY
RY30	028-1838	1	RELAY, BATTERY SWITCH PANEL		EMERGENCY START
RY31	028-1838	1	RELAY, BATTERY SWITCH PANEL		EMERGENCY START

318 VISTA - DIESEL BATTERY SWITCH PANEL ASSEMBLY

Owner's Manual Page 202

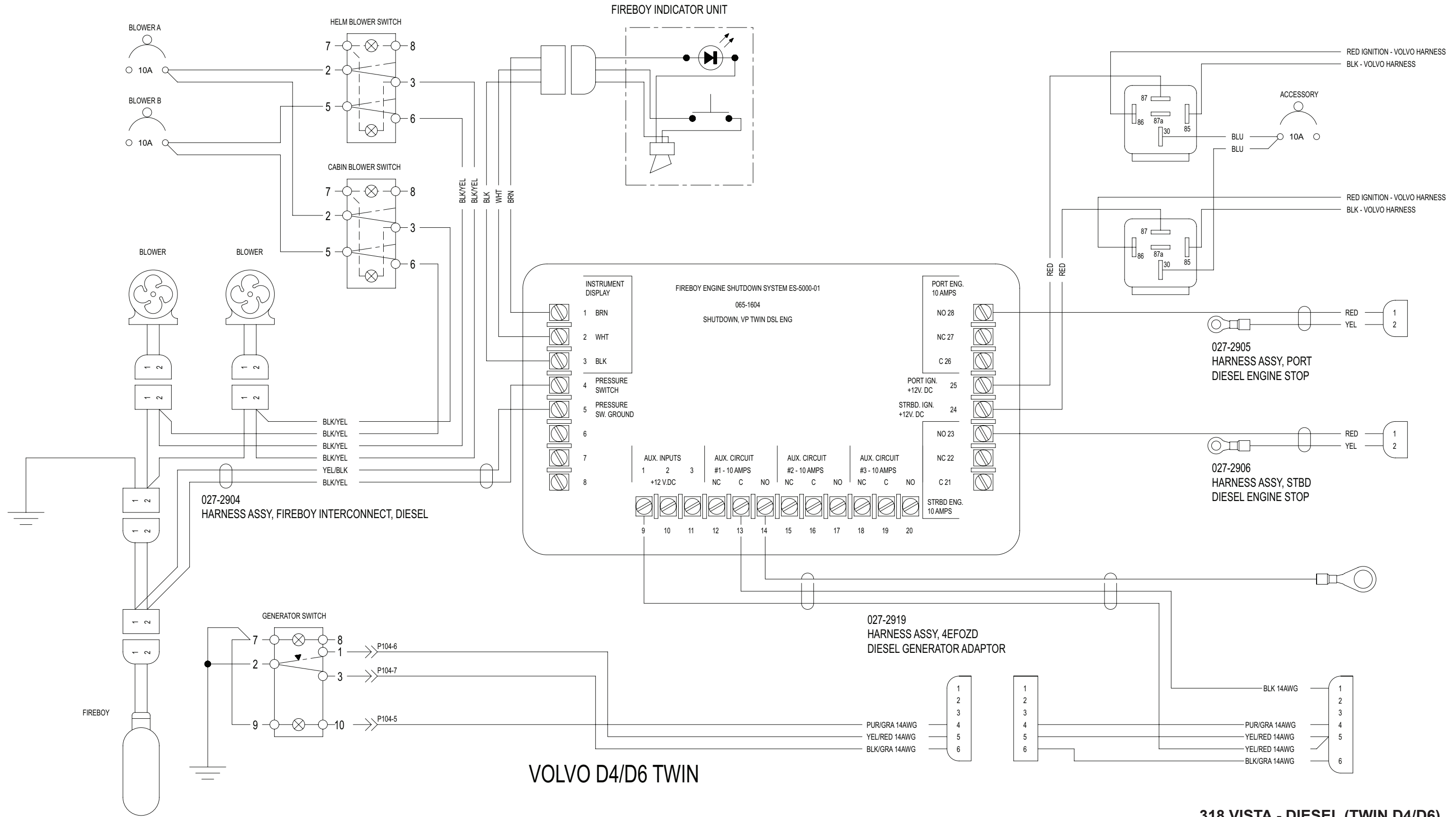

318 VISTA - DIESEL (TWIN D4/D6) FIREBOY CONNECTIONS
Owner's Manual Page 203

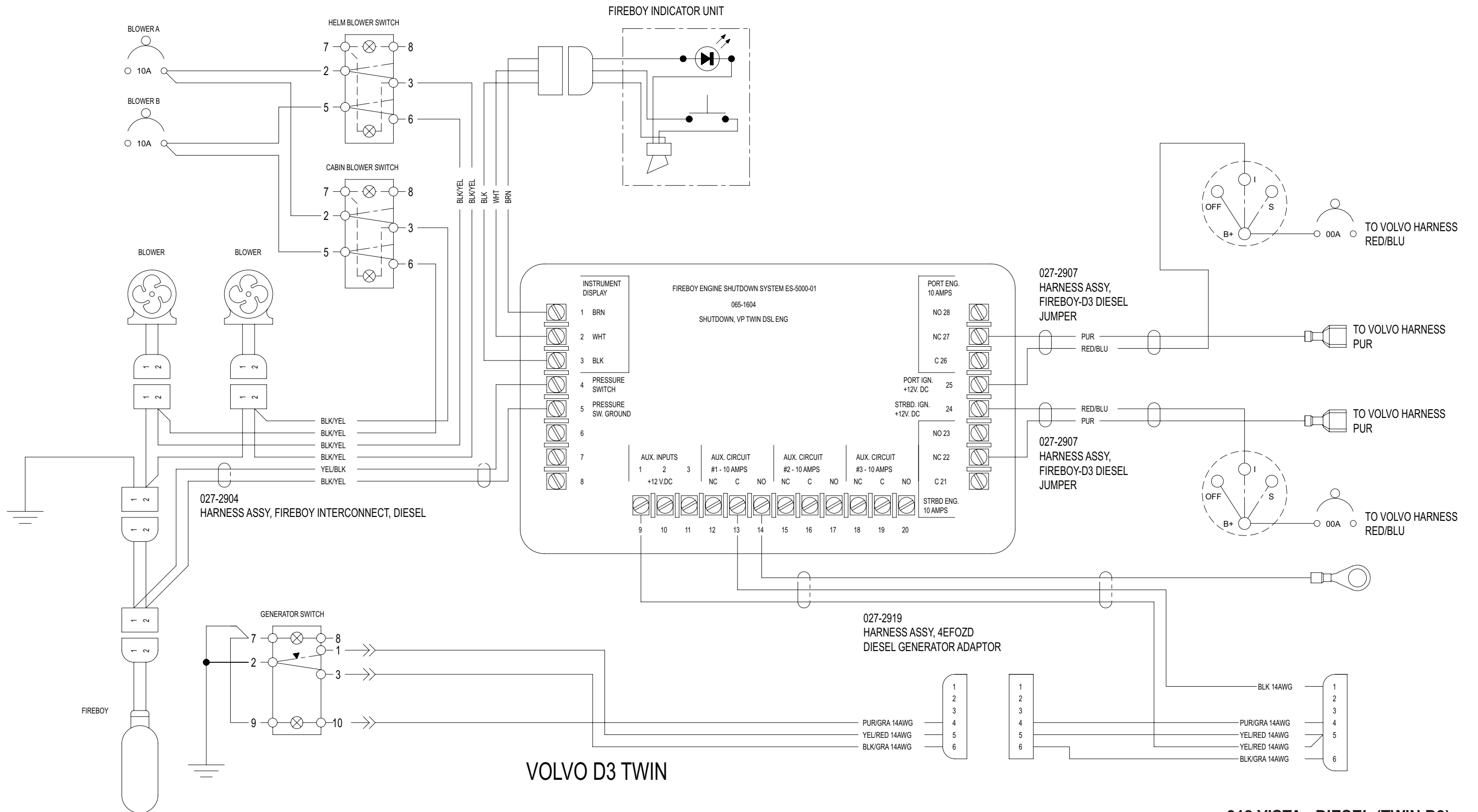

**318 VISTA - DIESEL (TWIN D3)
FIREBOY CONNECTIONS**

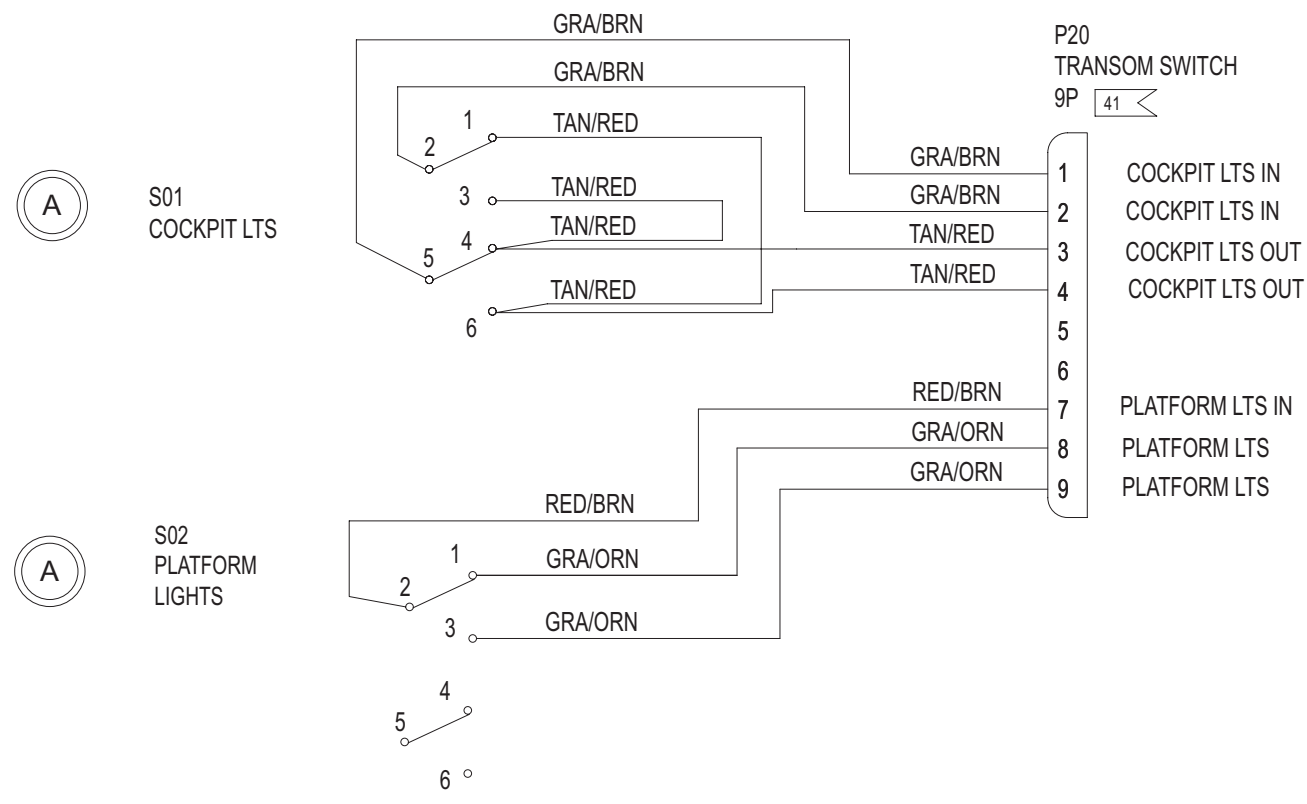

025-2940
PANEL, BLANK,
COCKPIT/PLATFORM 378V

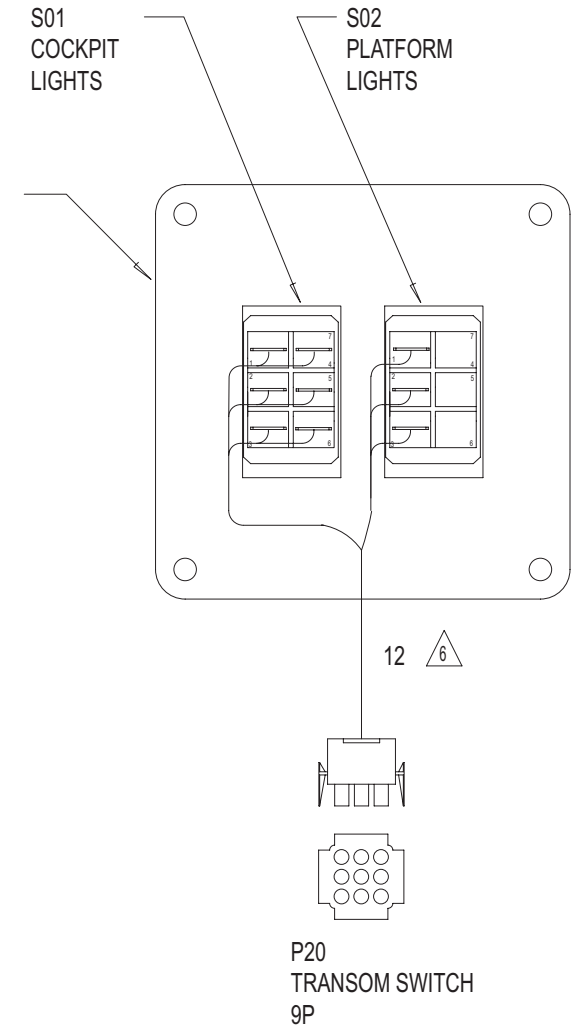

FOUR WINNS PARTS LIST

ITEM	PART NUMBER	QUANTITY	DESCRIPTION	FUNCTION	MANUFACTURER
	028-0390	7	PIN,UMNL,18-14	41	AMP
	028-0177	9	RECEPT,FASTON,.250,18-14	02	AMP
	025-2940	1	PANEL,BLANK, COCKPIT/PLATFORM 378V		AMP
P20	028-0449	1	PLUG, UMNL,9 CKT	TRANSOM SWITCH	AMP
(A) S01	028-1974	1	SWITCH, DPDT, ON-ON, CONTURA XI	COCKPIT LIGHTS	CARLING
(A) S02	028-1974	1	SWITCH, DPDT, ON-ON, CONTURA XI	PLATFORM LIGHTS	CARLING

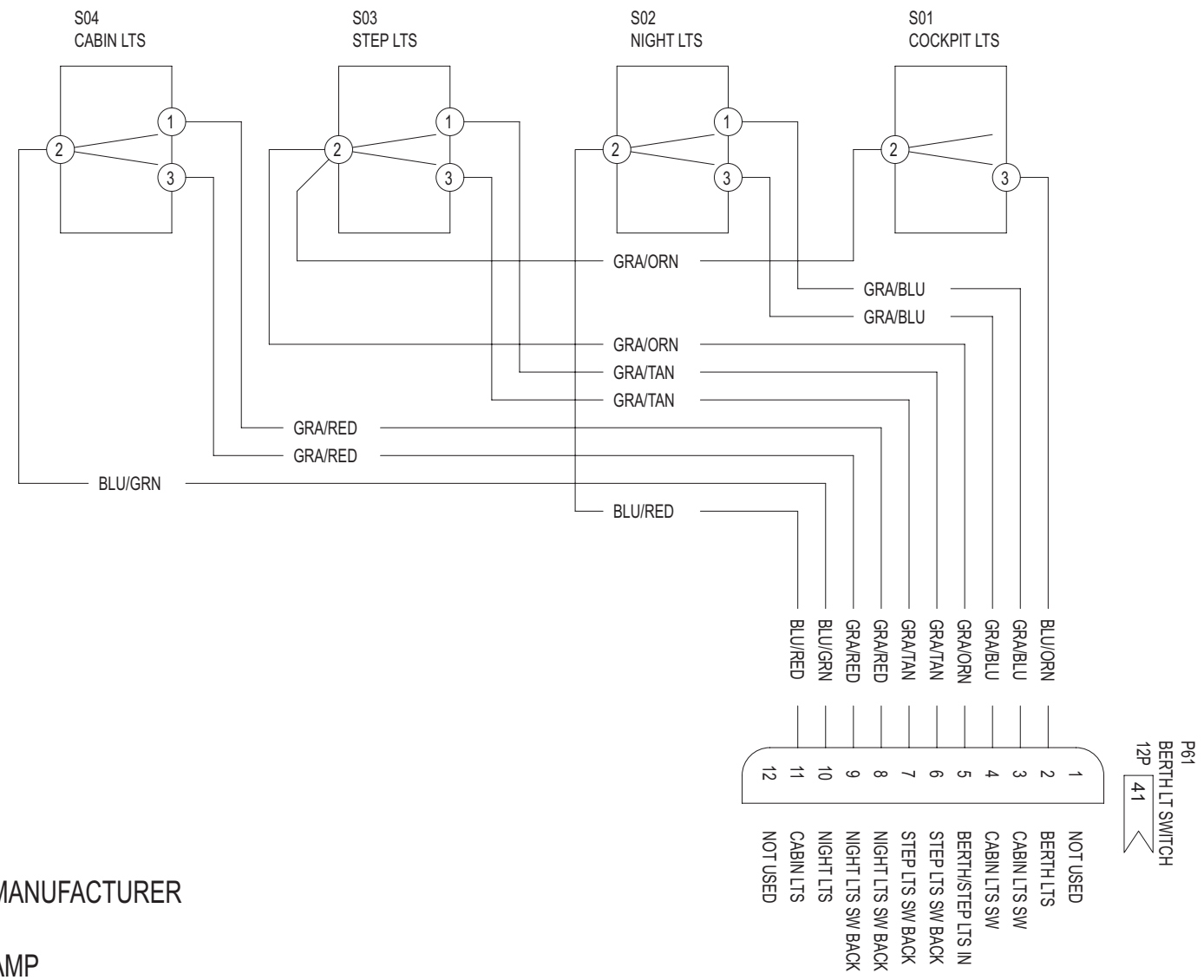
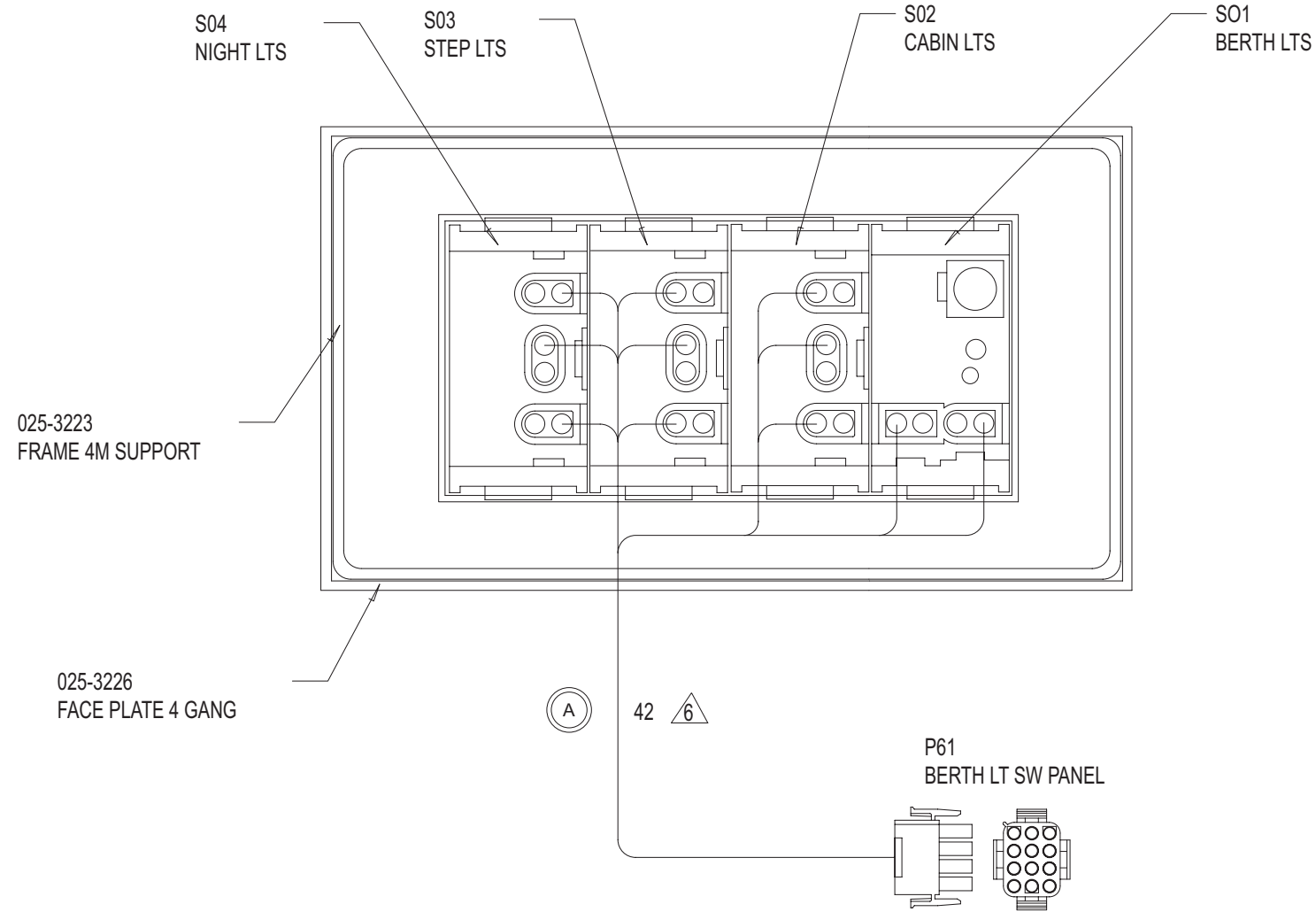

FOUR WINNS PARTS LIST

ITEM	PART NUMBER	QUANTITY	DESCRIPTION	FUNCTION	MANUFACTURER
-	028-0390	10	PIN,UMNL,18-14	41	AMP
P61	028-0451	1	PLUG,UMNL,12 CKT	BERTH LT SW PANEL	AMP
S01	028-1956	1	SWITCH,SPST ,IDEA	BERTH LTS	VIMAR
S02	028-1945	1	SWITCH,SPDT 2POS,IDEA	CABIN LTS	VIMAR
S03	028-1948	1	SWITCH,SPDT 2POS,IDEA	STEP LTS	VIMAR
S04	028-1947	1	SWITCH,SPDT 2POS,IDEA	NIGHT LTS	VIMAR
-	025-3223	1	FRAME 4M SUPPORT	-	VIMAR
-	025-3226	1	FACE PLATE 4 GANG	-	VIMAR

318 VISTA BERTH LIGHTS PANEL ASSEMBLY

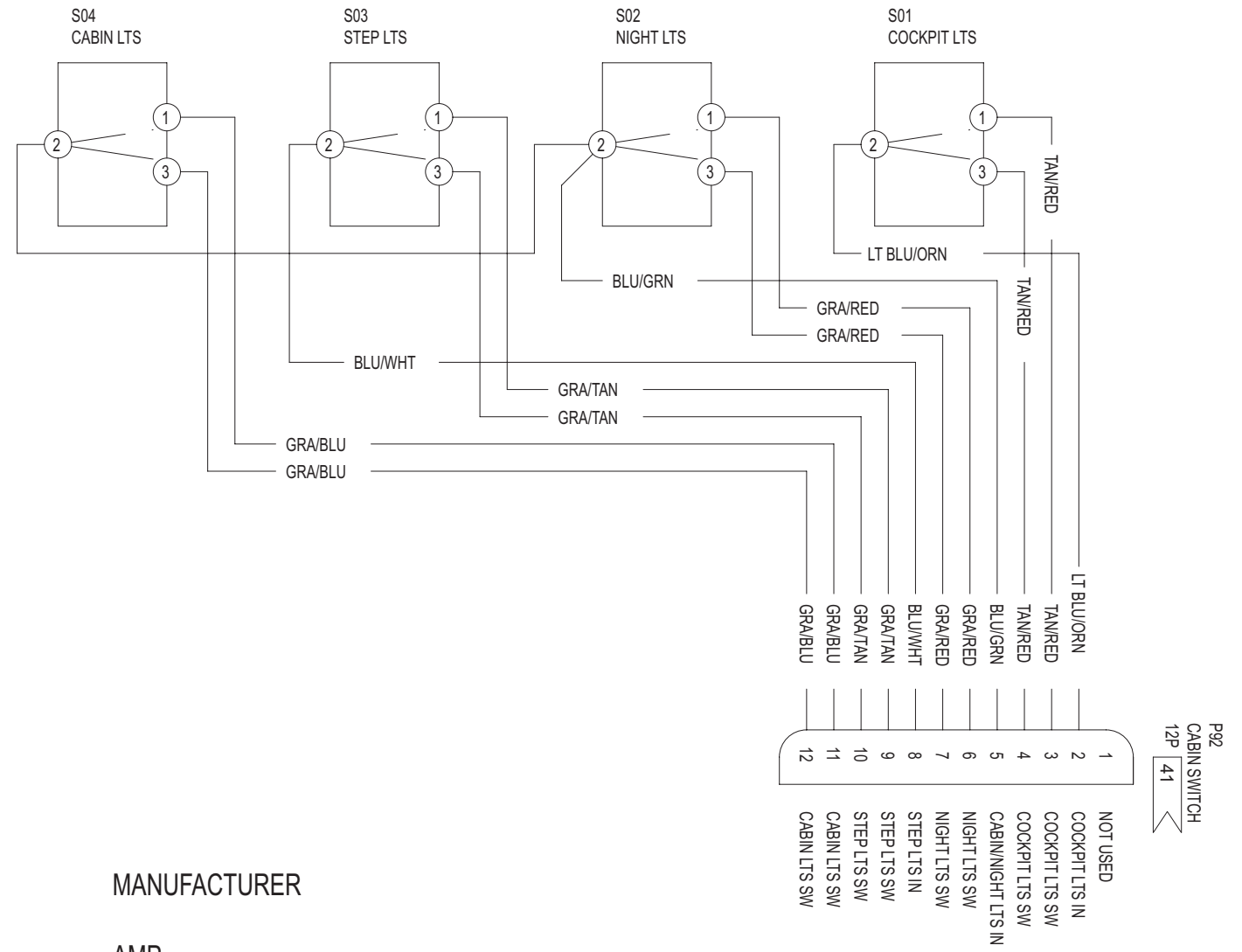
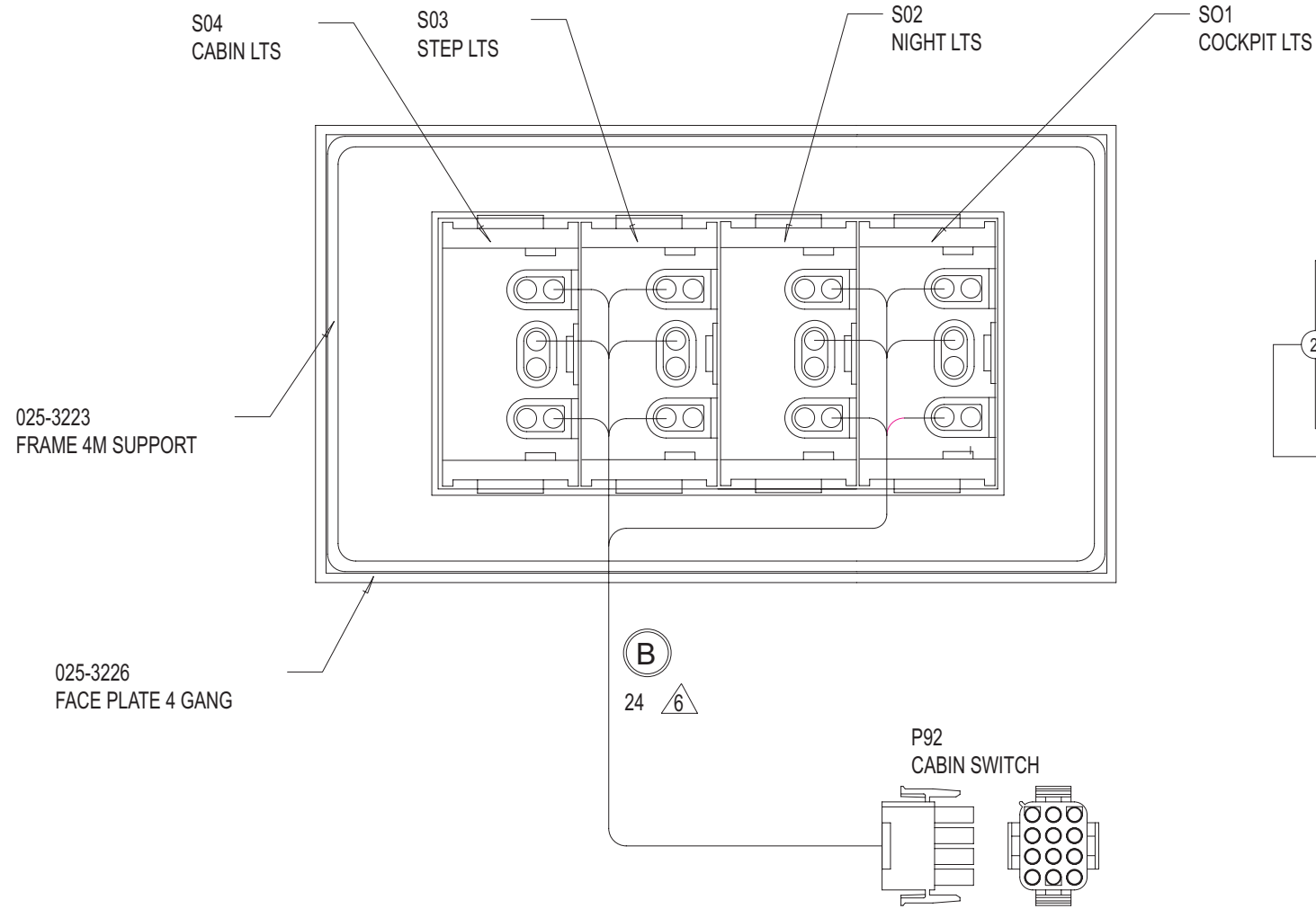

FOUR WINNS PARTS LIST

ITEM	PART NUMBER	QUANTITY	DESCRIPTION	FUNCTION	MANUFACTURER
-	028-0390	11	PIN,UMNL,18-14	41	AMP
P92	028-0451	1	PLUG,UMNL,12 CKT	CABIN SWITCH	AMP
S01	028-1940	1	SWITCH,SPDT 2POS,IDEA	COCKPIT LTS	VIMAR
S02	028-1947	1	SWITCH,SPDT 2POS,IDEA	NIGHT LTS	VIMAR
S03	028-1948	1	SWITCH,SPDT 2POS,IDEA	STEP LTS	VIMAR
S04	028-1945	1	SWITCH,SPDT 2POS,IDEA	CABIN LTS	VIMAR
-	025-3223	1	FRAME 4M SUPPORT	-	VIMAR
-	025-3226	1	FACE PLATE 4 GANG	-	VIMAR

318 VISTA CABIN LIGHTS PANEL ASSEMBLY

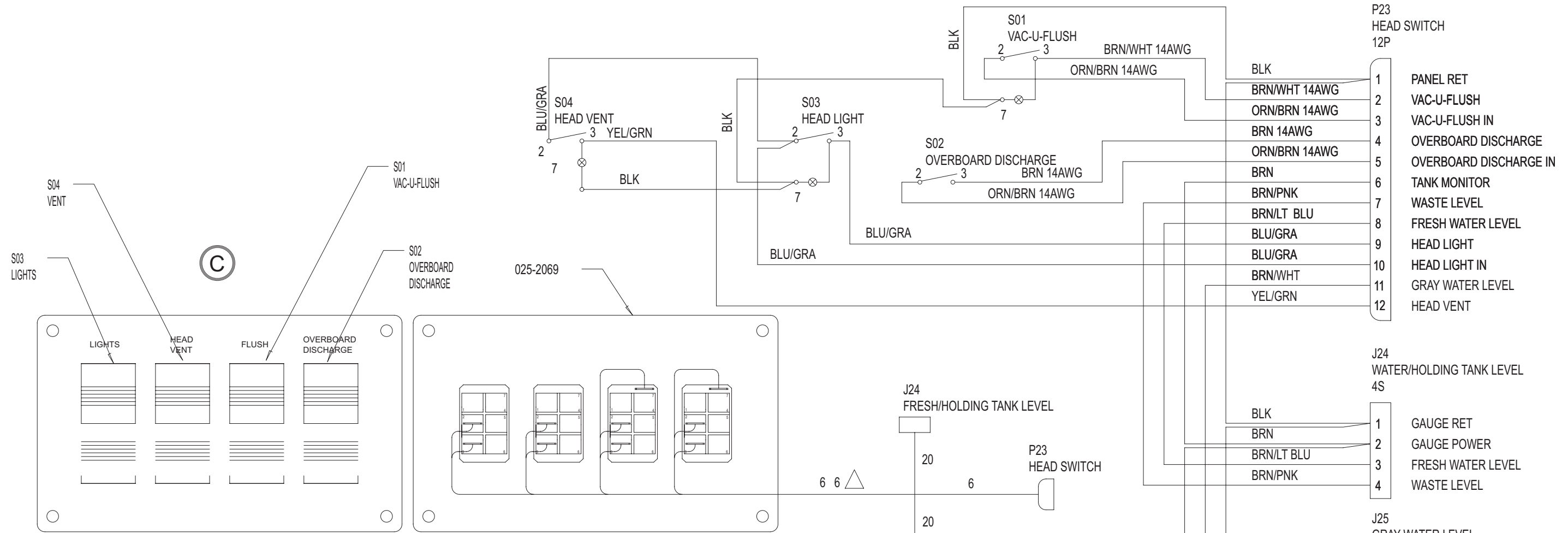

FOUR WINNS WIRE LIST

COLOR	GA	FIRST	PIN	TERM	NOTE	SECOND	PIN	TERM	NOTE	FUNCTION
BLK	16	P23	1	41	SA	S01	7	02	SF	SWITCH LT RET
BLK	16	S01	7	02	SF	S03	7	02	SD	SWITCH LT RET
BLK	16	P23	1	41	SA	P24	1	41	SB	WATER/HOLD LEVEL RET
BRN/WHT	14	P23	2	41		S01	3	02		VAC-U-FLUSH
ORN/BRN	14	P23	3	41		S01	2	02		VAC-U-FLUSH IN
BRN	14	P23	4	41		S02	3	02		OVERBOARD DISCHARGE
ORN/BRN	14	P23	5	41		S02	2	02		OVERBOARD DISCHARGE IN
BRN	16	P23	6	41		J24	2	42	SC	WATER/HOLD LEVEL +
BRN/PNK	16	P23	7	41		J24	4	42		WASTE LEVEL
BRN/LT BLU	16	P23	8	41		J24	3	42		FRESH WATER LEVEL
BLU/GRA	16	P23	9	41		S03	3	02		HEAD LT
BLU/GRA	16	P23	10	41		S03	2	02	SE	HEAD LT IN
BRN/WHT	16	P23	11	41		J25	3	42		GRAY LEVEL
BLK	16	J24	1	42	SB	J25	1	42		GRAY LEVEL RET
BRN	16	J24	2	42	SC	J25	2	42		GRAY LEVEL +
BLK	16	S03	7	02	SD	S04	7	02		SWITCH LT RET
BLU/GRA	16	S03	2	02	SE	S04	2	02		HEAD VENT IN
YEL/GRN	16	S04	3	02		P23	12	41		HEAD VENT

FOUR WINNS PARTS LIST

ITEM	PART NUMBER	QUANTITY	DESCRIPTION	FUNCTION	MANUFACTURER
	028-0177	11	RECEPT,FASTON,,250,18-14	02	AMP
	028-0390	12	PIN,UMNL,18-14	41	AMP
	028-0454	7	SOCKET,UMNL,18-14	42	AMP
	025-2069	1	PANEL,BLANK,CABIN LTS		
J24	028-0441	1	RECEPT,UMNL,4 CKT		AMP
J25	028-0441	1	RECEPT,UMNL,4 CKT		AMP
P23	028-0449	1	PLUG,UMNL,9 CKT		AMP
S01	028-0457	1	SWITCH,UNLIT ON OFF,CONT III		CARL SW
S02	028-0456	1	SWITCH, UNLIT (ON) OFF,CONT III		CARL SW
S03	028-0457	1	SWITCH,SPST ON OFF,CONT III		CARL SW
S04	028-0457	1	SWITCH,SPST,ON OFF,CONT III		CARL SW

318 VISTA
HEAD SWITCH
PANEL ASSEMBLY

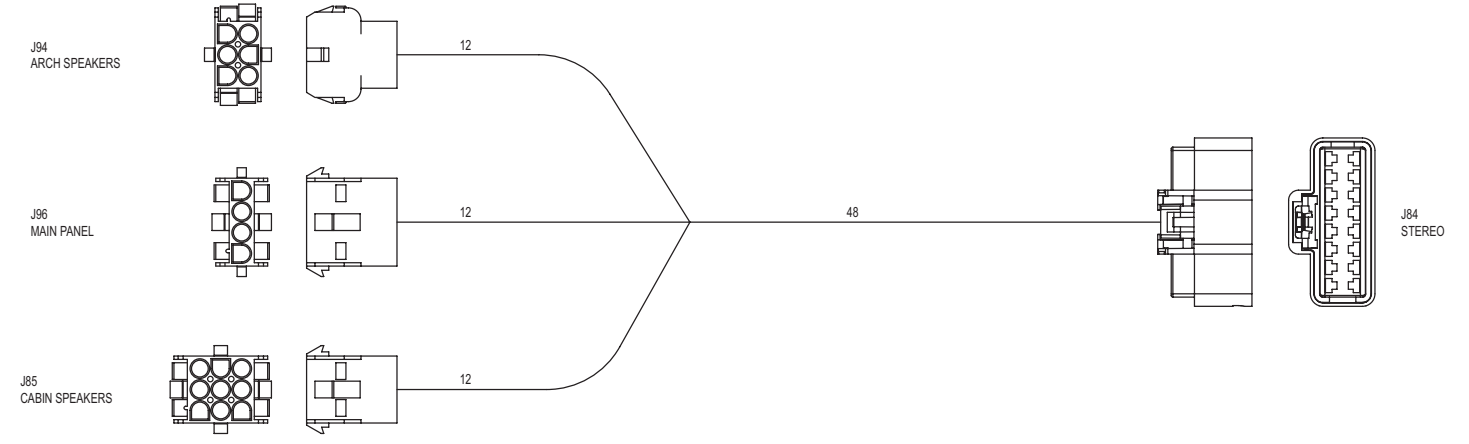
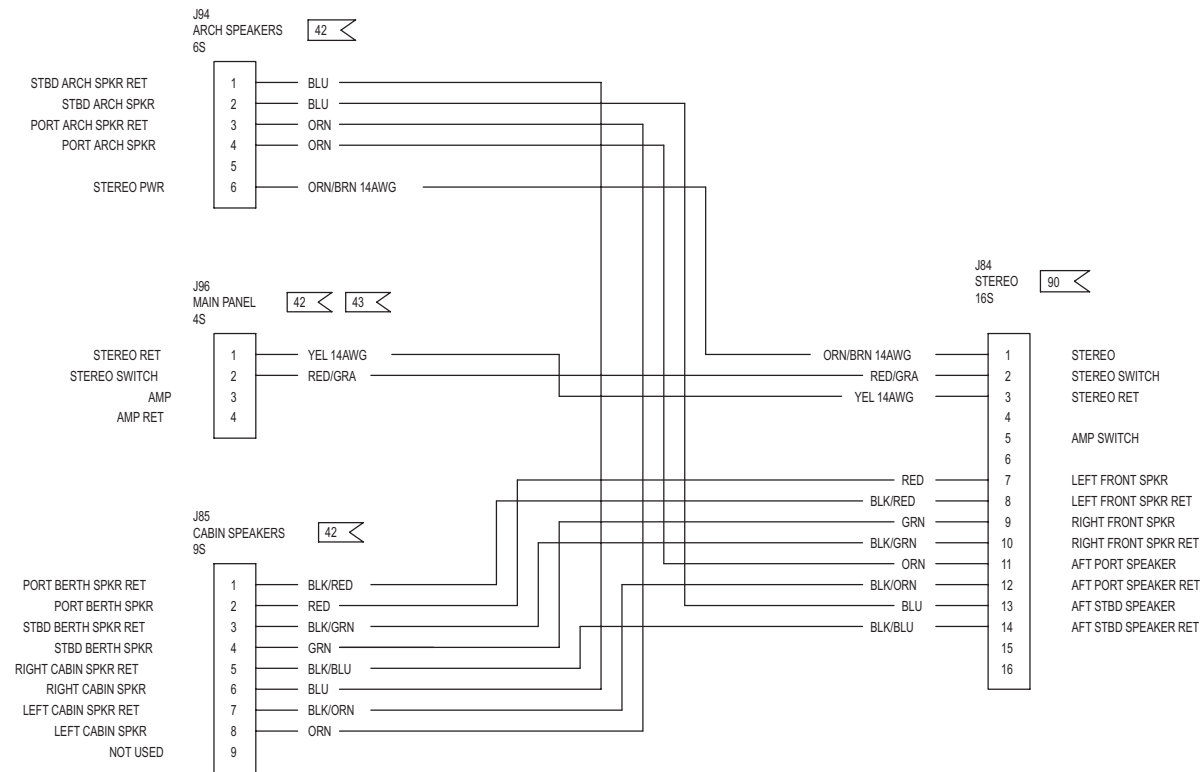

FOUR WINNS PARTS LIST

ITEM	PART NUMBER	QUANTITY	DESCRIPTION	FUNCTION	MANUFACTURER
-	028-0454	15	SOCKET,UMNL, 18-14	42	AMP
-	028-2005	11	TERM, FEMALE GT280 16	90	PACKARD
J85	028-0443	1	RECEPT,UMNL,9 CKT	CABIN SPEAKERS	AMP
J94	028-1933	1	RECEPT,UMNL,6 CKT	ARCH SPEAKERS	AMP
J96	028-0442	1	RECEPT,UMNL,4 CKT	MAIN PANEL	AMP
J84	028-2010	1	RECEPT,PACKARD,16 CKT	STEREO	PACKARD

**318 VISTA
STEREO W/OUT AMP
HARNES ASSEMBLY**

RCA Outputs: Refer to specific source unit model for proper connection configuration.

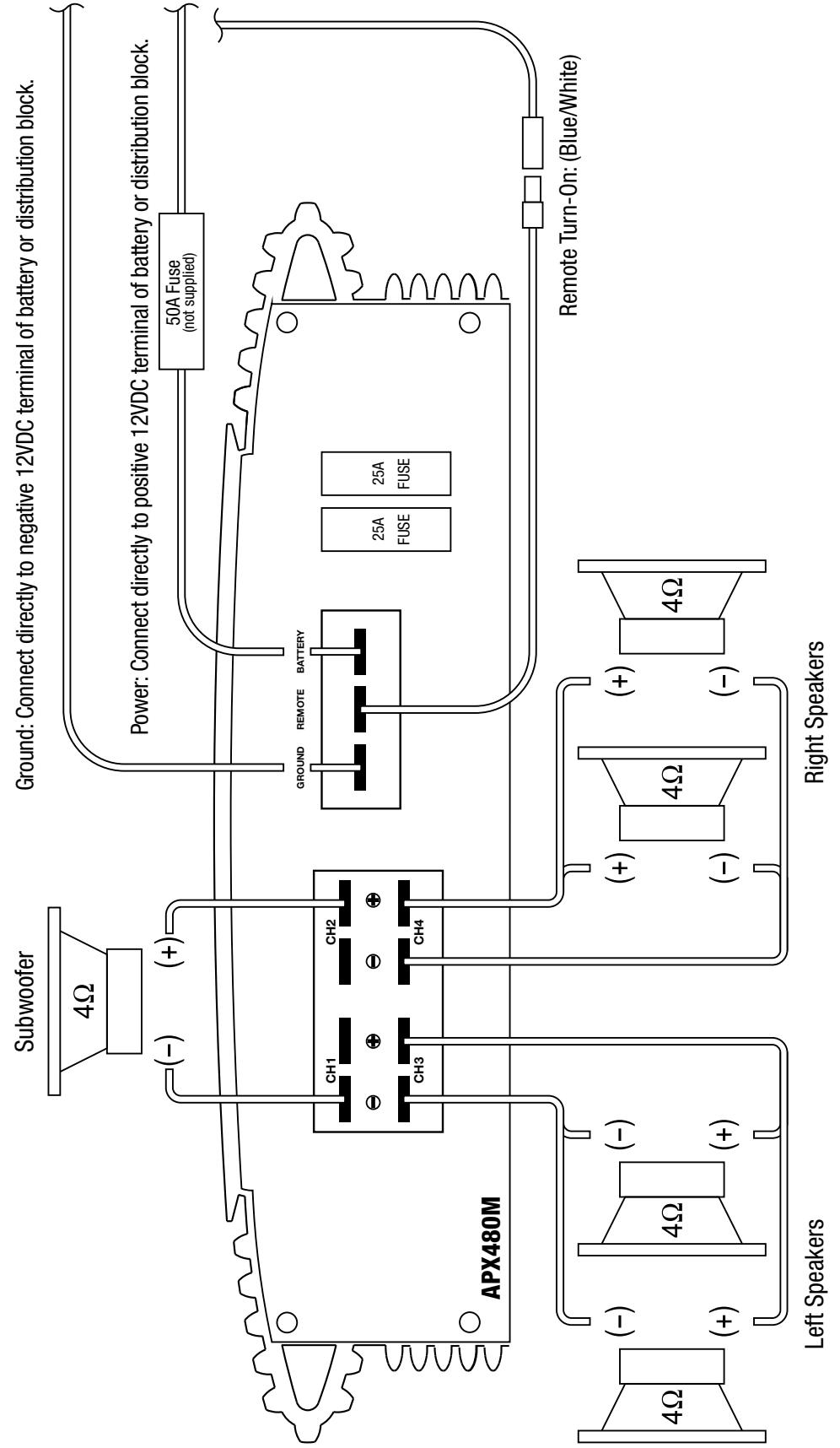
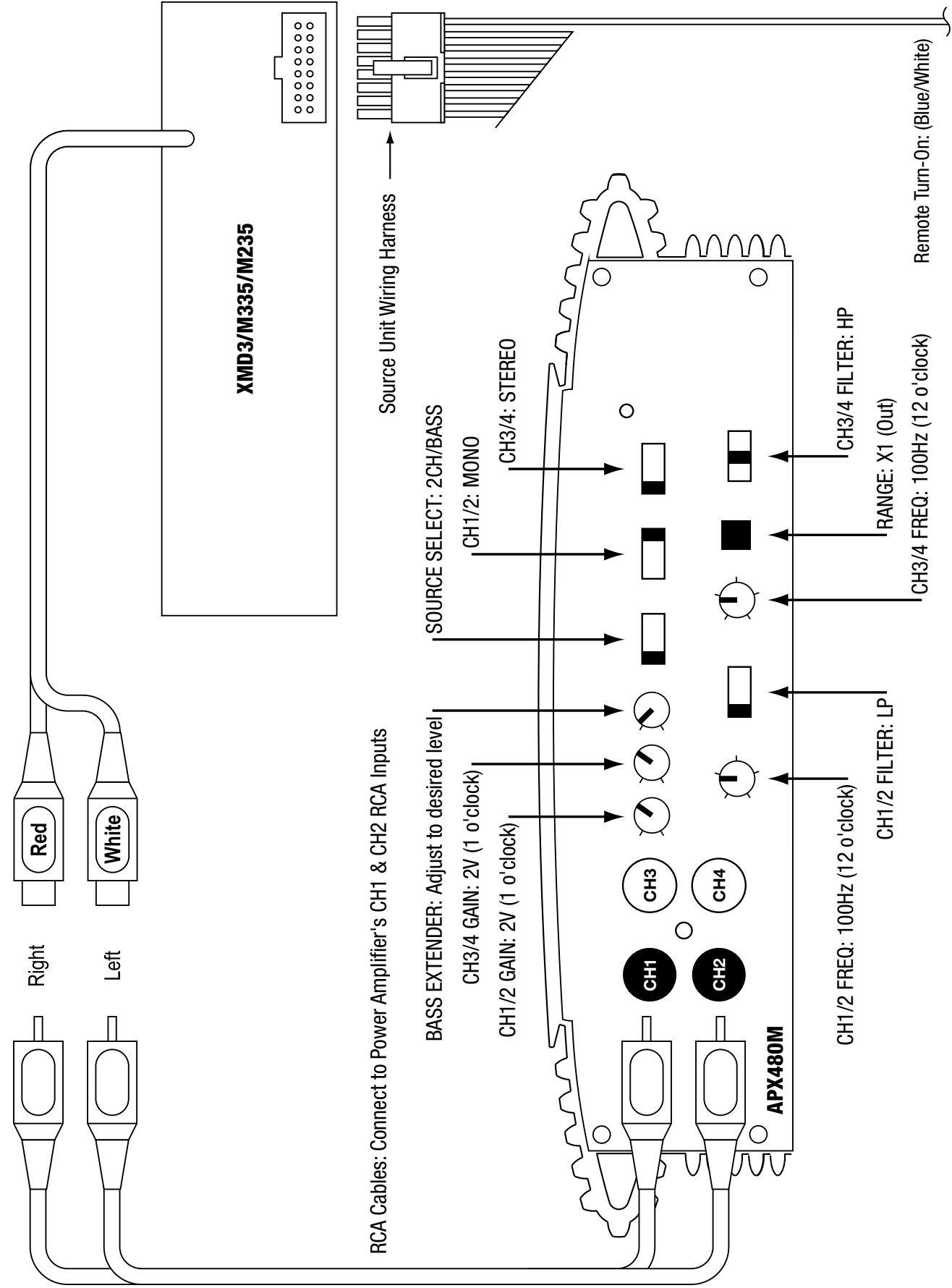

**CLARION AMPLIFIER - APX480M
 CONNECTIONS & SETTINGS**

ITEM	FW P/N	QUANTITY	DESCRIPTION	FUNCTION	MANUFACTURER
AA	025-3340	1	PANEL, BLANK, AC/DC, CE, 300V '05"	-	PORTAGE WIRE
AB	028-0177	10	TERMINAL, FASTON, .250, 18-14AWG	02	AMP 3-520107-2
AC	028-0179	8	TERMINAL, FASTON, .250, 12-10AWG	07	AMP 4-521098-2
AD	028-1929	2	TERMINAL, RING, #1/4, 4AWG	35	AMP 52043-3
AE	028-1988	2	TERMINAL, RING, #1/4, 4AWG	34	AMP 52043-2
AF	028-0191	17	TERMINAL, RING, #10, 16-14AWG	09	AMP 34161
AG	028-0196	4	TERMINAL, RING, 1/4", 12-10AWG	14	AMP 34855
AH	028-0195	89	TERMINAL, RING, #10, 12-10AWG	13	AMP 34854
AI	028-0198	2	TERMINAL, RING, #10, 6AWG	48	AMP 52265
AJ	028-1932	42	PIN, .140MNL, 14-10AWG	89	AMP 350201-1
AK	028-0453	6	PIN, UMNL, 12-10AWG	40	AMP 350922-3
AL	028-0390	13	PIN, UMNL, 18-14AWG	41	AMP 350873-3
AM	028-0454	51	SOCKET, UMNL, 18-14AWG	42	AMP 350874-3
CB01	028-0484	1	CKT BKR, 30A DP	GENERATOR MAIN	CARLINGSWITCH AA2-B0-34-630-5D1-C
CB02	028-0484	1	CKT BKR, 30A DP	GENERATOR MAIN	CARLINGSWITCH AA2-B0-34-630-5D1-C
CB03	028-0484	1	CKT BKR, 30A DP	SHORE 1	CARLINGSWITCH AA2-B0-34-630-5D1-C
CB04	028-0484	1	CKT BKR, 30A DP	SHORE 2	CARLINGSWITCH AA2-B0-34-630-5D1-C
CB05	028-0417	1	CKT BKR, 15A SP	BATTERY CHARGER	CARLINGSWITCH AA1-B0-34-615-5D1-C
CB06	028-0418	1	CKT BKR, 20A SP	WATER HEATER	CARLINGSWITCH AA1-B0-34-620-5D1-C
CB07	028-0418	1	CKT BKR, 20A SP	VACUUM	CARLINGSWITCH AA1-B0-34-620-5D1-C
CB08	028-0417	1	CKT BKR, 15A SP	COCKPIT REFRIGERATOR	CARLINGSWITCH AA1-B0-34-615-5D1-C
CB09	028-0417	1	CKT BKR, 15A SP	GALLEY REFRIGERATOR	CARLINGSWITCH AA1-B0-34-615-5D1-C
CB10	028-0418	1	CKT BKR, 20A SP	RANGE	CARLINGSWITCH AA1-B0-34-620-5D1-C
CB11	028-0418	1	CKT BKR, 20A SP	MICROWAVE	CARLINGSWITCH AA1-B0-34-620-5D1-C
CB12	028-0418	1	CKT BKR, 20A SP	GALLEY OUTLETS	CARLINGSWITCH AA1-B0-34-620-5D1-C
CB13	028-0417	1	CKT BKR, 15A SP	HEAD OUTLETS	CARLINGSWITCH AA1-B0-34-615-5D1-C
CB14	028-0417	1	CKT BKR, 15A SP	AFT CABIN OUTLETS	CARLINGSWITCH AA1-B0-34-615-5D1-C
CB15	028-0417	1	CKT BKR, 15A SP	FWD CABIN OUTLETS	CARLINGSWITCH AA1-B0-34-615-5D1-C
CB16	028-0418	1	CKT BKR, 20A SP	BERTH OUTLETS	CARLINGSWITCH AA1-B0-34-620-5D1-C
CB17	028-1984	1	CKT BKR, 50A SP	HELM MAIN	CARLINGSWITCH AA1-B0-34-650-5D1-C
CB18	028-1984	1	CKT BKR, 50A SP	CABIN MAIN	CARLINGSWITCH AA1-B0-34-650-5D1-C
CB19	028-0417	1	CKT BKR, 15A SP	FRESH WATER PUMP	CARLINGSWITCH AA1-B0-34-615-5D1-C
CB20	028-0416	1	CKT BKR, 10A SP	FWD BILGE PUMP	CARLINGSWITCH AA1-B0-34-610-5D1-C
CB21	028-0415	1	CKT BKR, 05A SP	SHOWER SUMP PUMP	CARLINGSWITCH AA1-B0-34-450-5D1-C
CB22	028-0396	1	CKT BKR, 10A MAG	VAC-U-FLUSH	MECHANICAL PRODUCTS 1600-100-100
CB23	028-0396	1	CKT BKR, 10A MAG	OVERBOARD DISCHARGE	MECHANICAL PRODUCTS 1600-100-100
CB24	028-1983	1	CKT BKR, 40A SP	STEREO AMPLIFIER	CARLINGSWITCH AA1-B0-34-640-5D1-C
CB25	028-0467	1	CKT BKR, 15A THERMAL	TV/DVD	ETA 1638-071-04-P10 15 00A
CB26	028-0467	1	CKT BKR, 15A THERMAL	12VDC RECEPTACLES	ETA 1638-071-04-P10 15 00A
CB27	028-0396	1	CKT BKR, 10A THERMAL	CABIN LTS/NIGHT LTS	MECHANICAL PRODUCTS 1600-100-100
CB28	028-0396	1	CKT BKR, 10A THERMAL	BERTH LTS/STEP LTS	MECHANICAL PRODUCTS 1600-100-100
CB29	028-0393	1	CKT BKR, 05A THERMAL	HEAD LTS/HEAD VENT	MECHANICAL PRODUCTS 1600-100-050
CB30	028-0396	1	CKT BKR, 10A THERMAL	GALLEY LTS/READING LTS	MECHANICAL PRODUCTS 1600-100-100
CB31	028-0417	1	CKT BKR, 15A SP	GALLEY REFRIGERATOR	CARLINGSWITCH AA1-B0-34-615-5D1-C
CB32	028-0393	1	CKT BKR, 05A THERMAL	STEREO	MECHANICAL PRODUCTS 1600-100-050
DP01	028-0319	1	PLUG, DOME, .500	ACCESSORY 2	HEYCO 2643
CB34	028-0393	1	CKT BKR, 05A SP	PANEL LTS	CARLINGSWITCH AA1-B0-34-450-5D1-C
DS01	028-0531	1	INDICATOR, NEON, GREEN	SHORE 1 SYSTEM ACTIVE	SOLICO 1852-11-12-20340
DS02	028-0530	1	INDICATOR, NEON, RED	SHORE 1 REVERSE POLARITY	SOLICO 1852-11-12-20310
DS03	028-0531	1	INDICATOR, NEON, GREEN	SHORE 2 SYSTEM ACTIVE	SOLICO 1852-11-12-20340
DS04	028-0530	1	INDICATOR, NEON, RED	SHORE 2 REVERSE POLARITY	SOLICO 1852-11-12-20310
DS05	028-1759	1	INDICATOR, LED, GREEN	SYS 1 GALVANIC ISO - NORMAL	SOLICO 1812-11-12-20340
DS06	028-1760	1	INDICATOR, LED, RED	SYS 1 GALVANIC ISO - FAULT	SOLICO 1812-11-12-20310
DS07	028-1759	1	INDICATOR, LED, GREEN	SYS 2 GALVANIC ISO - NORMAL	SOLICO 1812-11-12-20340
DS08	028-1760	1	INDICATOR, LED, RED	SYS 2 GALVANIC ISO - FAULT	SOLICO 1812-11-12-20310
SO1	028-1901	1	SWITCH, SPST, ON-OFF	BLOWER	CARLINGSWITCH VID16GCB-GRCN-191
SO2	028-1966	1	SWITCH, SPDT, (ON)-OFF-ON	GENERATOR CONTROL	CARLINGSWITCH VID20UCB-GRCE4-1XX
SO3	028-1985	1	SWITCH, DPDT, ON-OFF-ON	AC METER SELECT	CARLINGSWITCH 26M51-73
MM01	028-0428	1	METER, AC VOLTS 300V	AC LINE VOLTAGE	MODUTEC 2W-AVV-300
MM02	028-0429	1	METER, DC VOLTS 15V	DC LINE VOLTAGE	MODUTEC 2W-DVV-15
TB01	028-0300	1	BLOCK, TERMINAL, 10 POSITION	AC SHORE CONNECTIONS	BEAU 28010
TB02	N/A	1	BUSS BAR, 20 POSITION	AC NEUTRAL CONNECTIONS	PORTAGE WIRE
TB03	028-0302	1	BUSS BAR, 10 GANG	AC EARTH GROUND CONNECTIONS	WES GARDE WT804-010
TB04	028-0302	1	BUSS BAR, 10 GANG	DC RETURNS	WES GARDE WT804-010
TB05	028-1989	1	CONNECTOR, HI AMP CABLE	SHIP SYSTEMS	BLUE SEA 2011
TB06	028-1989	1	CONNECTOR, HI AMP CABLE	HELM POWER	BLUE SEA 2011
J67	028-0446	1	RECEPTACLE, UMNL, 15 CKT	CABIN MAIN/PORT DECK	AMP 1-480711-0
J92	028-0445	1	RECEPTACLE, UMNL, 12 CKT	CABIN MAIN/CABIN SWITCH	AMP 1-480709-0
J20	028-0445	1	RECEPTACLE, UMNL, 12 CKT	CABIN MAIN/STBD HULL	AMP 1-480709-0
J120	028-0442	1	RECEPTACLE, UMNL, 4 CKT	CABIN MAIN/MID CABIN	AMP 1-480703-0
J188	028-0441	1	RECEPTACLE, UMNL, 2 CKT	DVD PLAYER	AMP 1-480699-0
J215	028-0441	1	RECEPTACLE, UMNL, 2 CKT	STEP LIGHTS	AMP 1-480699-0
P21	028-0094	1	HOUSING, .140MNL, 3 CKT	GALLEY REFRIGERATOR	AMP 1-350347-0
P183	028-0094	1	HOUSING, .140MNL, 3 CKT	MICROWAVE	AMP 1-350347-0
P185	028-0094	1	HOUSING, .140MNL, 3 CKT	AIR CONDITIONER	AMP 1-350347-0
P24	028-0094	1	HOUSING, .140MNL, 3 CKT	COCKPIT REFRIGERATOR	AMP 1-350347-0
P25	028-0094	1	HOUSING, .140MNL, 3 CKT	GALLEY OUTLETS	AMP 1-350347-0
P144	028-0094	1	HOUSING, .140MNL, 3 CKT	HEAD OUTLETS	AMP 1-350347-0
P143	028-0094	1	HOUSING, .140MNL, 3 CKT	DINETTE OUTLETS	AMP 1-350347-0
P191	028-0094	1	HOUSING, .140MNL, 3 CKT	MID CABIN OUTLETS	AMP 1-350347-0
P193	028-0094	1	HOUSING, .140MNL, 3 CKT	VACUUM	AMP 1-350347-0
P195	028-0094	1	HOUSING, .140MNL, 3 CKT	STBD V-BERTH OUTLETS	AMP 1-350347-0
P142	028-0094	1	HOUSING, .140MNL, 3 CKT	PORT V-BERTH OUTLETS	AMP 1-350347-0
P32	028-0094	1	HOUSING, .140MNL, 3 CKT	BATTERY CHARGER	AMP 1-350347-0
P200	028-0094	1	HOUSING, .140MNL, 3 CKT	WATER HEATER	AMP 1-350347-0
P201	028-0094	1	HOUSING, .140MNL, 3 CKT	RANGE	AMP 1-350347-0
P96	028-0448	1	PLUG, UMNL, 4 CKT	STEREO	AMP 1-480702-0
P97	028-1970	1	PLUG, UMNL, 1 CKT	ISO 1 NEUTRAL	AMP 1-350867-0
P98	028-1971	1	PLUG, UMNL, 3 CKT	ISO 1 REMOTE INDICATOR	AMP 1-480700-0
P189	028-0447	1	PLUG, UMNL, 2 CKT	ISO 1 POWER	AMP 1-480698-0
P100	028-1970	1	PLUG, UMNL, 1 CKT	ISO 2 NEUTRAL	AMP 1-350867-0
P101	028-1971	1	PLUG, UMNL, 3 CKT	ISO 2 REMOTE INDICATOR	AMP 1-480700-0
P102	028-0447	1	PLUG, UMNL, 2 CKT	ISO 2 POWER	AMP 1-480698-0
P104	028-0451	1	PLUG, UMNL, 12CKT	CABIN MAIN/AFT SYSTEMS	AMP 1-480708-0
P141	028-0094	1	HOUSING, .140MNL, 3 CKT	FWD BATTERY CHARGER	AMP 1-350347-0
P300	028-0451	1	PLUG, UMNL, 6CKT	ISOLATOR INDICATOR	AMP 1-350715-1
J300	028-0094	1	RECEPTACLE, UMNL, 6CKT	ISOLATOR INDICATOR	AMP 1-350781-1

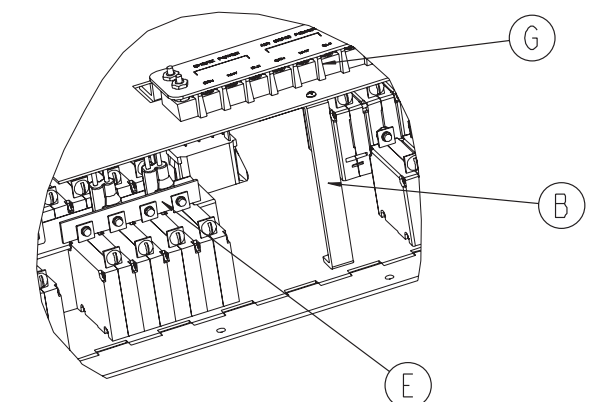
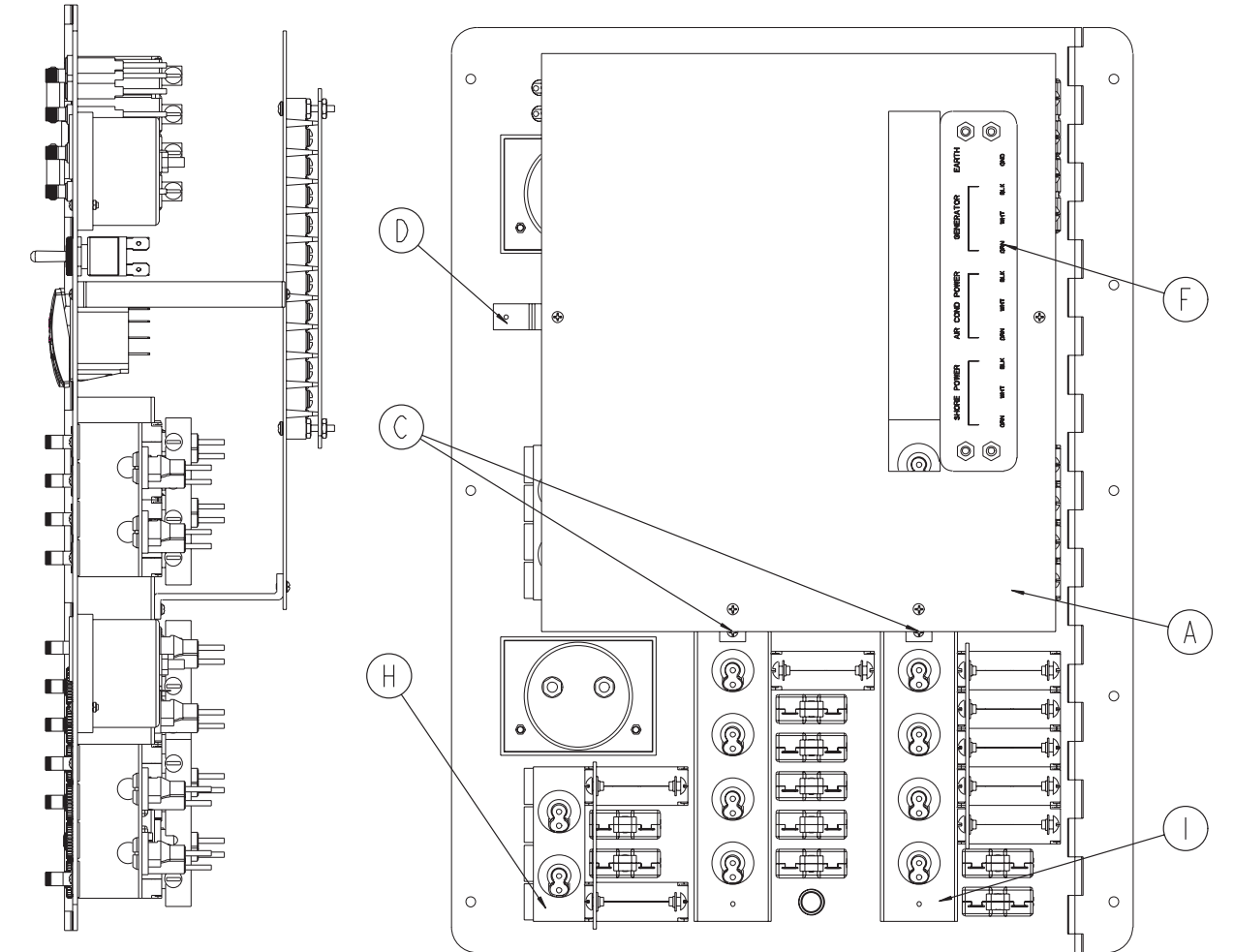
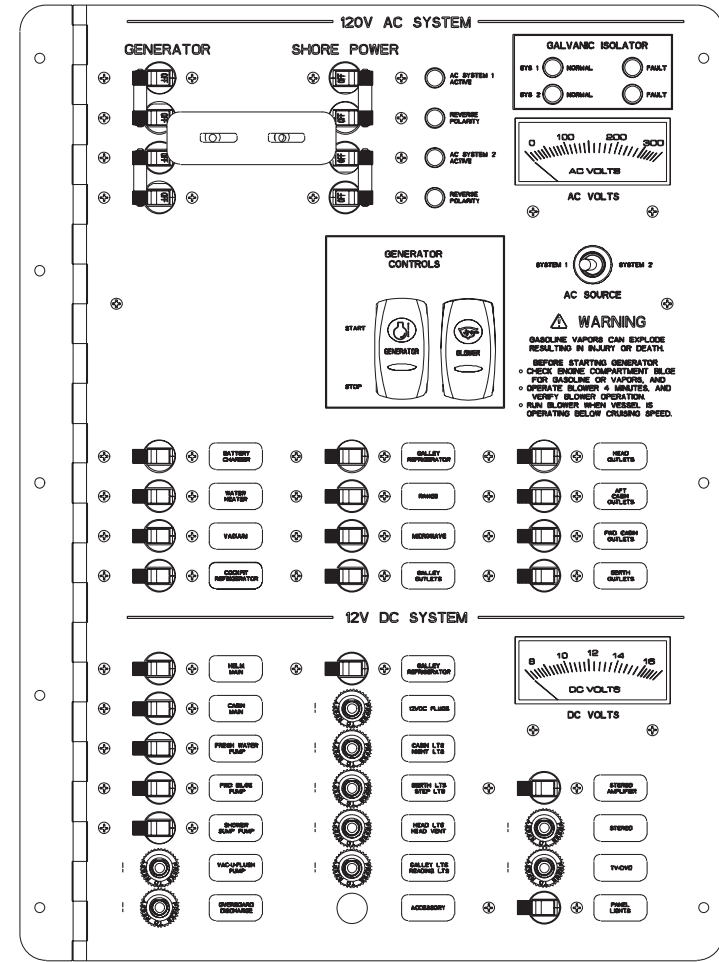

**318 VISTA
AC/DC
PANEL ASSEMBLY
(1 of 4)**
Owner's Manual Page 211

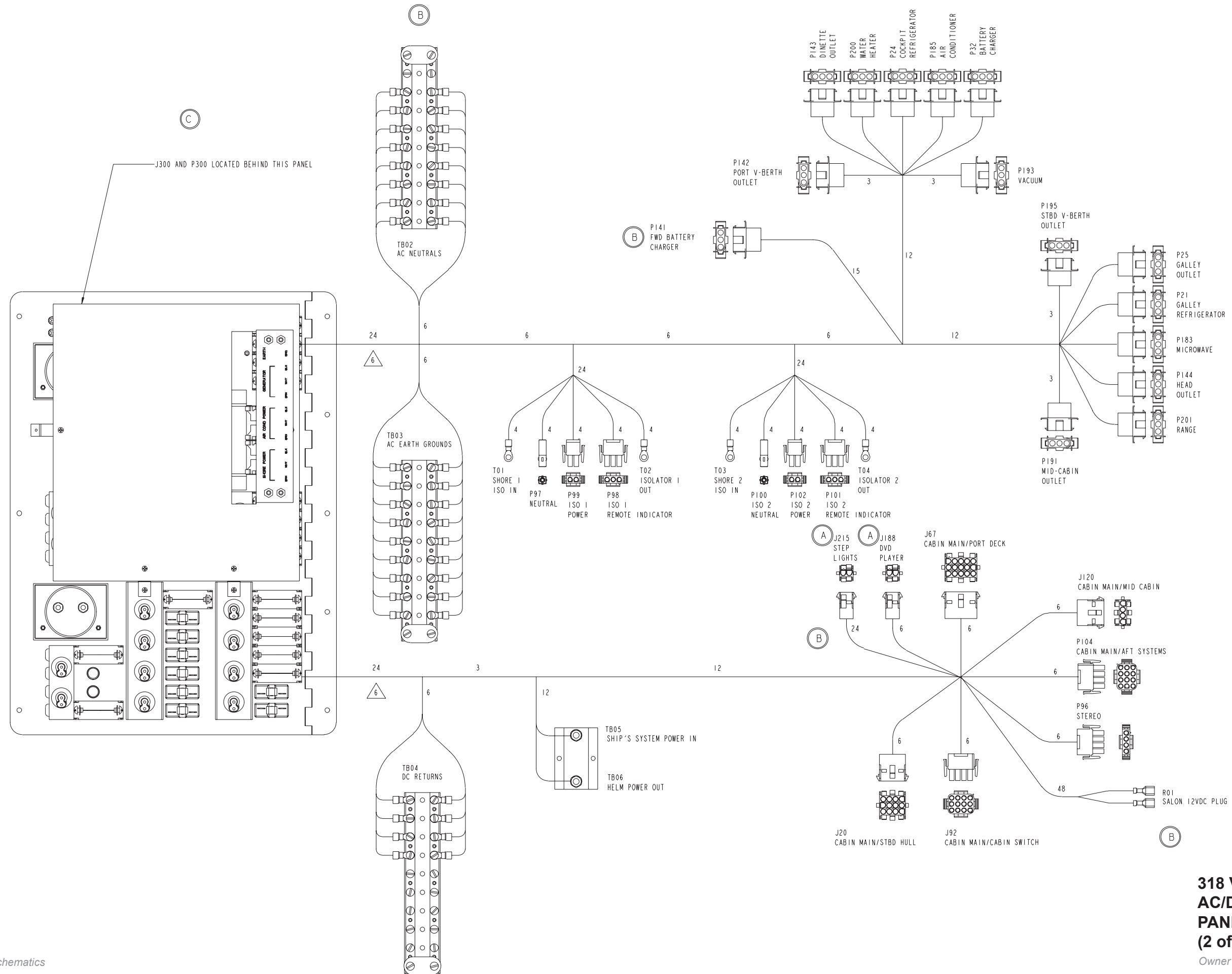

**318 VISTA
AC/DC
PANEL ASSEMBLY
(2 of 4)**

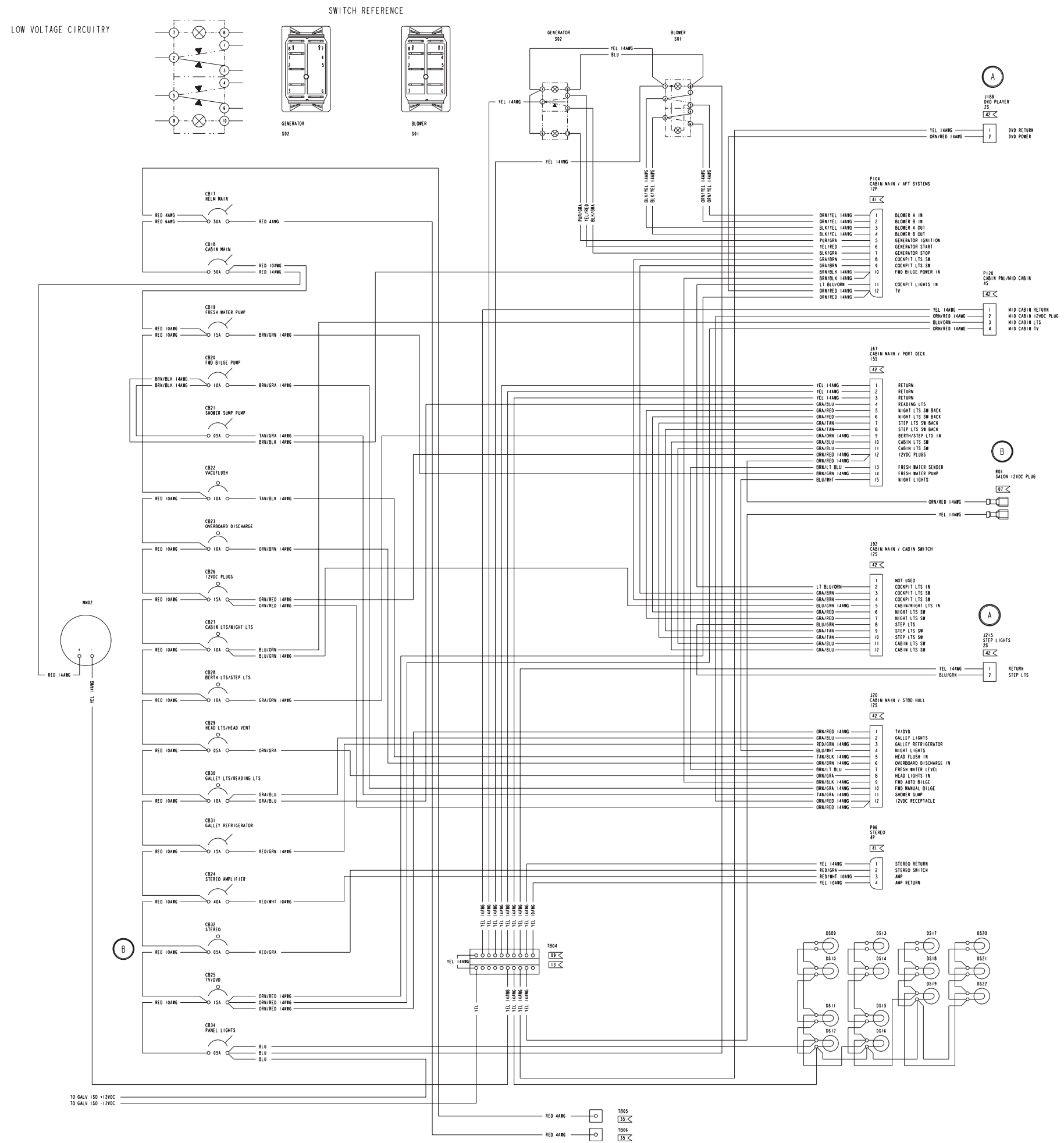

**318 VISTA
AC/DC
PANEL ASSEMBLY
(3 of 4)**
Owner's Manual Page 213

HI VOLTAGE CIRCUITRY

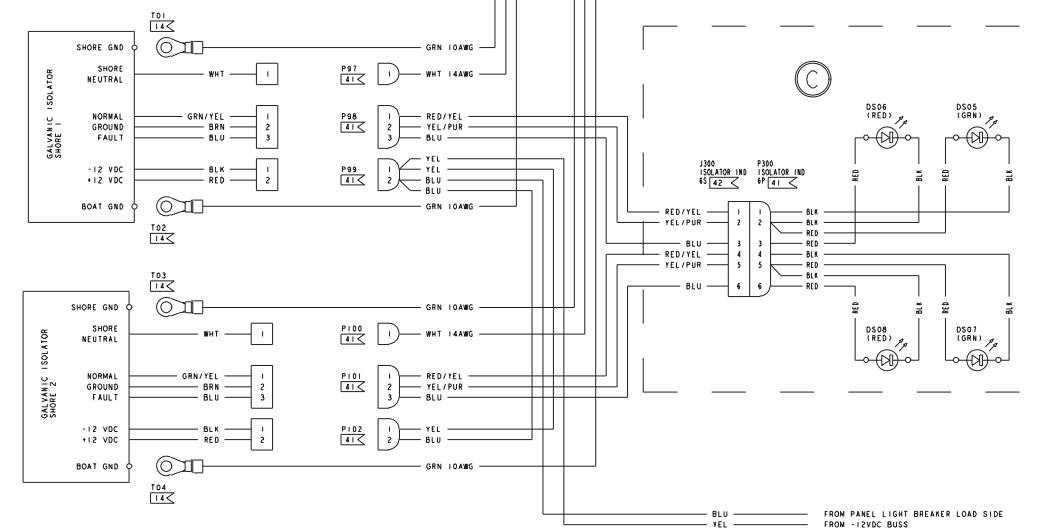
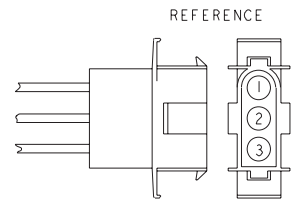
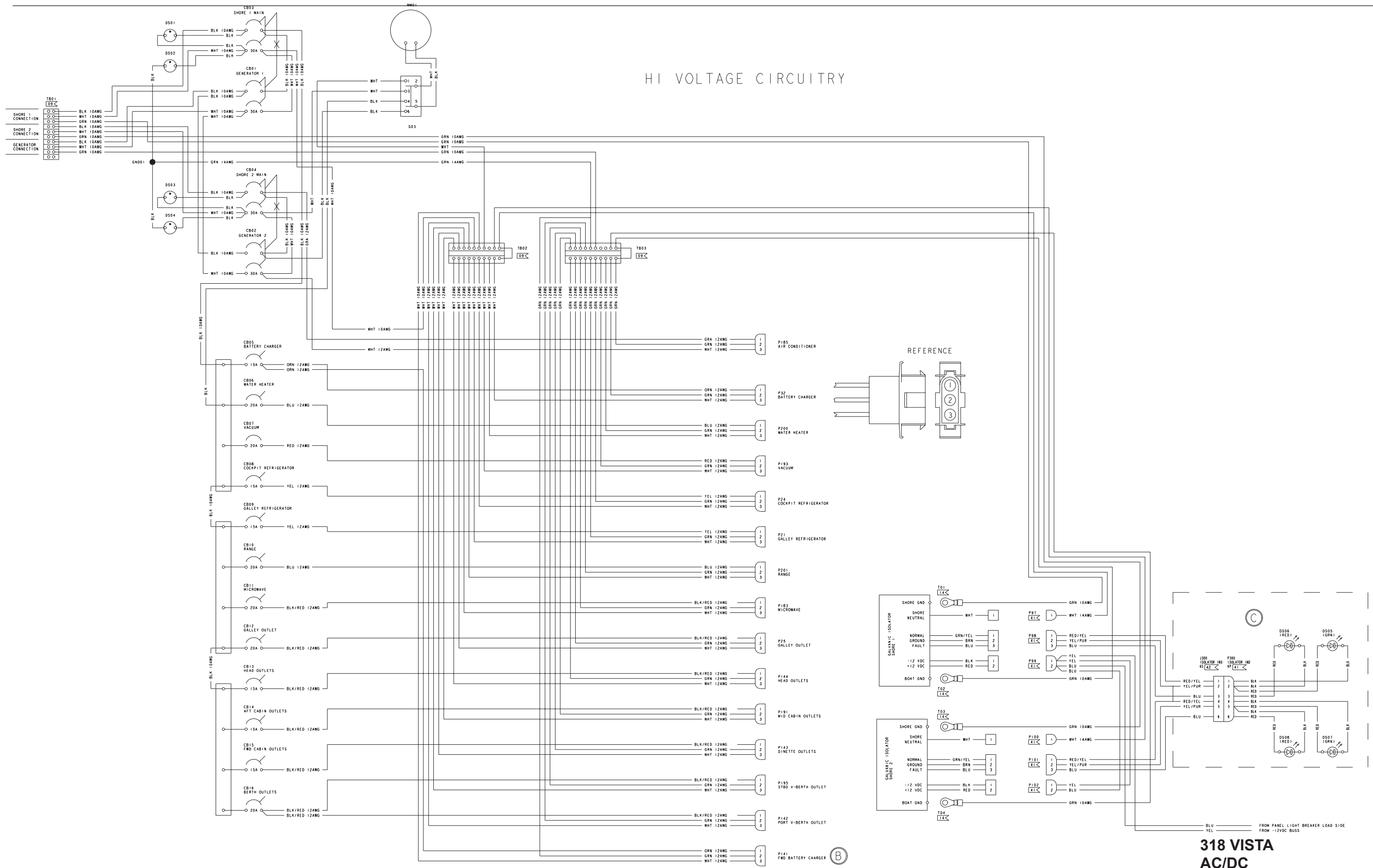

ITEM	FW P/N	QUANTITY	DESCRIPTION	FUNCTION	MANUFACTURER
AA	025-3340	1	PANEL, BLANK, AC/DC, CE, 308V "05"	-	PORTAGE WIRE
AB	028-0177	10	TERMINAL, FASTON, .250, 18-14AWG	02	AMP 3-520107-2
AC	028-0179	8	TERMINAL, FASTON, .250, 12-10AWG	07	AMP 4-521098-2
AD	028-1929	2	TERMINAL, RING, #1/4, 4AWG	35	AMP 52043-3
AE	028-1988	2	TERMINAL, RING, #10, 4AWG	34	AMP 52043-2
AF	028-0191	17	TERMINAL, RING, #10, 16-14AWG	09	AMP 34161
AG	028-0196	4	TERMINAL, RING, 1/4", 12-10AWG	14	AMP 34855
AH	028-0195	89	TERMINAL, RING, #10, 12-10AWG	13	AMP 34854
AI	028-0198	2	TERMINAL, RING, #10, 6AWG	48	AMP 52265
AJ	028-1932	42	PIN, .140MNL, 14-10AWG	89	AMP 350201-1
AK	028-0453	6	PIN, UMNL, 12-10AWG	40	AMP 350922-3
AL	028-0390	13	PIN, UMNL, 18-14AWG	41	AMP 350873-3
AM	028-0454	51	SOCKET, UMNL, 18-14AWG	42	AMP 350874-3
CB01	028-0484	1	CKT BKR, 30A DP	GENERATOR MAIN	CARLINGSWITCH AA2-B0-34-630-SD1-C
CB02	028-0484	1	CKT BKR, 30A DP	GENERATOR MAIN	CARLINGSWITCH AA2-B0-34-630-SD1-C
CB03	028-0484	1	CKT BKR, 30A DP	SHORE 1	CARLINGSWITCH AA2-B0-34-630-SD1-C
CB04	028-0484	1	CKT BKR, 30A DP	SHORE 2	CARLINGSWITCH AA2-B0-34-630-SD1-C
CB05	028-0417	1	CKT BKR, 15A SP	BATTERY CHARGER	CARLINGSWITCH AA1-B0-34-615-SD1-C
CB06	028-0418	1	CKT BKR, 20A SP	WATER HEATER	CARLINGSWITCH AA1-B0-34-620-SD1-C
CB07	028-0418	1	CKT BKR, 20A SP	VACUUM	CARLINGSWITCH AA1-B0-34-620-SD1-C
CB08	028-0417	1	CKT BKR, 15A SP	COCKPIT REFRIGERATOR	CARLINGSWITCH AA1-B0-34-615-SD1-C
CB09	028-0417	1	CKT BKR, 15A SP	GALLEY REFRIGERATOR	CARLINGSWITCH AA1-B0-34-615-SD1-C
CB10	028-0418	1	CKT BKR, 20A SP	RANGE	CARLINGSWITCH AA1-B0-34-620-SD1-C
CB11	028-0418	1	CKT BKR, 20A SP	MICROWAVE	CARLINGSWITCH AA1-B0-34-620-SD1-C
CB12	028-0418	1	CKT BKR, 20A SP	GALLEY OUTLETS	CARLINGSWITCH AA1-B0-34-620-SD1-C
CB13	028-0417	1	CKT BKR, 15A SP	HEAD OUTLETS	CARLINGSWITCH AA1-B0-34-615-SD1-C
CB14	028-0417	1	CKT BKR, 15A SP	AFT CABIN OUTLETS	CARLINGSWITCH AA1-B0-34-615-SD1-C
CB15	028-0417	1	CKT BKR, 15A SP	FWD CABIN OUTLETS	CARLINGSWITCH AA1-B0-34-615-SD1-C
CB16	028-0418	1	CKT BKR, 20A SP	BERTH OUTLETS	CARLINGSWITCH AA1-B0-34-620-SD1-C
CB17	028-1984	1	CKT BKR, 50A SP	HELM MAIN	CARLINGSWITCH AA1-B0-34-650-SD1-C
CB18	028-1984	1	CKT BKR, 50A SP	CABIN MAIN	CARLINGSWITCH AA1-B0-34-650-SD1-C
CB19	028-0417	1	CKT BKR, 15A SP	FRESH WATER PUMP	CARLINGSWITCH AA1-B0-34-615-SD1-C
CB20	028-0416	1	CKT BKR, 10A SP	FWD BILGE PUMP	CARLINGSWITCH AA1-B0-34-610-SD1-C
CB21	028-0415	1	CKT BKR, 05A SP	SHOWER SUMP PUMP	CARLINGSWITCH AA1-B0-34-450-SD1-C
CB22	028-0396	1	CKT BKR, 10A MAG	VAC-U-LUSH	MECHANICAL PRODUCTS 1600-100-100
CB23	028-0396	1	CKT BKR, 10A MAG	OVERBOARD DISCHARGE	MECHANICAL PRODUCTS 1600-100-100
CB24	028-1983	1	CKT BKR, 40A SP	STEREO AMPLIFIER	CARLINGSWITCH AA1-B0-34-640-SD1-C
CB25	028-0467	1	CKT BKR, 15A THERMAL	TV/DVD	ETA 1658-G21-04-PI0 15.00A
CB26	028-0467	1	CKT BKR, 15A THERMAL	12VDC RECEPTACLES	ETA 1658-G21-04-PI0 15.00A
CB27	028-0396	1	CKT BKR, 10A THERMAL	CABIN LTS/NIGHT LTS	MECHANICAL PRODUCTS 1600-100-100
CB28	028-0396	1	CKT BKR, 10A THERMAL	BERTH LTS/STEP LTS	MECHANICAL PRODUCTS 1600-100-100
CB29	028-0393	1	CKT BKR, 05A THERMAL	HEAD LTS/HEAD VENT	MECHANICAL PRODUCTS 1600-100-050
CB30	028-0396	1	CKT BKR, 10A THERMAL	GALLEY LTS/READING LTS	MECHANICAL PRODUCTS 1600-100-100
CB31	028-0417	1	CKT BKR, 15A SP	GALLEY REFRIGERATOR	CARLINGSWITCH AA1-B0-34-615-SD1-C
CB32	028-0393	1	CKT BKR, 05A THERMAL	STEREO	MECHANICAL PRODUCTS 1600-100-050
DP01	028-0319	1	PLUG, DOME, .500	ACCESSORY 2	HEVCO 2643
CB34	028-0393	1	CKT BKR, 05A SP	PANEL LTS	CARLINGSWITCH AA1-B0-34-450-SD1-C
CB35	028-0297	1	RCCB 1	SHORE 1 GROUND FAULT	GE VYNC4977/99222/030
CB36	028-0297	1	RCCB 2	SHORE 2 GROUND FAULT	GE VYNC4977/99222/030
DS01	028-0531	1	INDICATOR, NEON, GREEN	SHORE 1 SYSTEM ACTIVE	SOLICO 1852-11-12-20340
DS02	028-0530	1	INDICATOR, NEON, RED	SHORE 1 REVERSE POLARITY	SOLICO 1852-11-12-20310
DS03	028-0531	1	INDICATOR, NEON, GREEN	SHORE 2 SYSTEM ACTIVE	SOLICO 1852-11-12-20340
DS04	028-0530	1	INDICATOR, NEON, RED	SHORE 2 REVERSE POLARITY	SOLICO 1852-11-12-20310
DS05	028-1759	1	INDICATOR, LED, GREEN	SYS 1 GALVANIC ISO - NORMAL	SOLICO 1812-11-12-20340
DS06	028-1760	1	INDICATOR, LED, RED	SYS 1 GALVANIC ISO - FAULT	SOLICO 1812-11-12-20310
DS07	028-1759	1	INDICATOR, LED, GREEN	SYS 2 GALVANIC ISO - NORMAL	SOLICO 1812-11-12-20310
DS08	028-1760	1	INDICATOR, LED, RED	SYS 2 GALVANIC ISO - FAULT	SOLICO 1812-11-12-20340
S01	028-1901	1	SWITCH, SPST, ON-OFF	BLOWER	CARLINGSWITCH WIDG2CCB-GRCK-191
S02	028-1966	1	SWITCH, SPDT, ON-OFF-ON	GENERATOR CONTROL	CARLINGSWITCH W7D2UCCB-GRCE4-1XX
S03	028-1985	1	SWITCH, DPDT, ON-OFF-ON	AC METER SELECT	CARLINGSWITCH ZGM51-73
MM01	028-0428	1	METER, AC VOLTS 300V	AC LINE VOLTAGE	MODUTEC 2W-AVV-300
MM02	028-0429	1	METER, DC VOLTS 15V	DC LINE VOLTAGE	MODUTEC 2W-DVV-15
TB01	028-0300	1	BLOCK, TERMINAL 10 POSITION	AC SHORE CONNECTIONS	BEAU 28010
TB02	N/A	1	BUSS BAR, 20 POSITION	AC NEUTRAL CONNECTIONS	PORTAGE WIRE
TB03	028-0302	1	BUSS BAR, 10 GANG	AC EARTH GROUND CONNECTIONS	WES GARDE WTB04-010
TB04	028-0302	1	BUSS BAR, 10 GANG	DC RETURNS	WES GARDE WTB04-010
TB05	028-1989	1	CONNECTOR, HI AMP CABLE	SHIP SYSTEMS	BLUE SEA 2011
TB06	028-1989	1	CONNECTOR, HI AMP CABLE	HELM POWER	BLUE SEA 2011
J67	028-0446	1	RECEPTACLE, UMNL, 15 CKT	CABIN MAIN/PORT DECK	AMP 1-480711-0
J92	028-0445	1	RECEPTACLE, UMNL, 12 CKT	CABIN MAIN/CABIN SWITCH	AMP 1-480709-0
J20	028-0445	1	RECEPTACLE, UMNL, 12 CKT	CABIN MAIN/STBD HULL	AMP 1-480709-0
J120	028-0442	1	RECEPTACLE, UMNL, 4 CKT	CABIN MAIN/MID CABIN	AMP 1-480703-0
J188	028-0441	1	RECEPTACLE, UMNL, 2 CKT	DVD PLAYER	AMP 1-480699-0
J215	028-0441	1	RECEPTACLE, UMNL, 2 CKT	STEP LIGHTS	AMP 1-480699-0
P21	028-0094	1	HOUSING, .140MNL, 3 CKT	GALLEY REFRIGERATOR	AMP 1-350347-0
P183	028-0094	1	HOUSING, .140MNL, 3 CKT	MICROWAVE	AMP 1-350347-0
P185	028-0094	1	HOUSING, .140MNL, 3 CKT	AIR CONDITIONER	AMP 1-350347-0
P24	028-0094	1	HOUSING, .140MNL, 3 CKT	COCKPIT REFRIGERATOR	AMP 1-350347-0
P25	028-0094	1	HOUSING, .140MNL, 3 CKT	GALLEY OUTLETS	AMP 1-350347-0
P144	028-0094	1	HOUSING, .140MNL, 3 CKT	HEAD OUTLETS	AMP 1-350347-0
P143	028-0094	1	HOUSING, .140MNL, 3 CKT	DINETTE OUTLETS	AMP 1-350347-0
P191	028-0094	1	HOUSING, .140MNL, 3 CKT	MID CABIN OUTLETS	AMP 1-350347-0
P193	028-0094	1	HOUSING, .140MNL, 3 CKT	VACUUM	AMP 1-350347-0
P195	028-0094	1	HOUSING, .140MNL, 3 CKT	STBD V-BERTH OUTLETS	AMP 1-350347-0
P142	028-0094	1	HOUSING, .140MNL, 3 CKT	PORT V-BERTH OUTLETS	AMP 1-350347-0
P32	028-0094	1	HOUSING, .140MNL, 3 CKT	BATTERY CHARGER	AMP 1-350347-0
P200	028-0094	1	HOUSING, .140MNL, 3 CKT	WATER HEATER	AMP 1-350347-0
P201	028-0094	1	HOUSING, .140MNL, 3 CKT	RANGE	AMP 1-350347-0
P96	028-0448	1	PLUG, UMNL, 4 CKT	STEREO	AMP 1-480702-0
P97	028-1970	1	PLUG, UMNL, 1 CKT	ISO 1 NEUTRAL	AMP 1-350867-0
P98	028-1971	1	PLUG, UMNL, 3 CKT	ISO 1 REMOTE INDICATOR	AMP 1-480700-0
P189	028-0447	1	PLUG, UMNL, 2 CKT	ISO 1 POWER	AMP 1-480698-0
P100	028-1970	1	PLUG, UMNL, 1 CKT	ISO 2 NEUTRAL	AMP 1-350867-0
P101	028-1971	1	PLUG, UMNL, 3 CKT	ISO 2 REMOTE INDICATOR	AMP 1-480700-0
P102	028-0447	1	PLUG, UMNL, 2 CKT	ISO 2 POWER	AMP 1-480698-0
P104	028-0451	1	PLUG, UMNL, 12CKT	CABIN MAIN/AFT SYSTEMS	AMP 1-480708-0
P141	028-0094	1	HOUSING, .140MNL, 3 CKT	FWD BATTERY CHARGER	AMP 1-350347-0
P300	028-0451	1	PLUG, UMNL, 6CKT	ISOLATOR INDICATOR	AMP 1-350715-1
J300	028-0094	1	RECEPTACLE, UMNL, 6CKT	ISOLATOR INDICATOR	AMP 1-350718-1

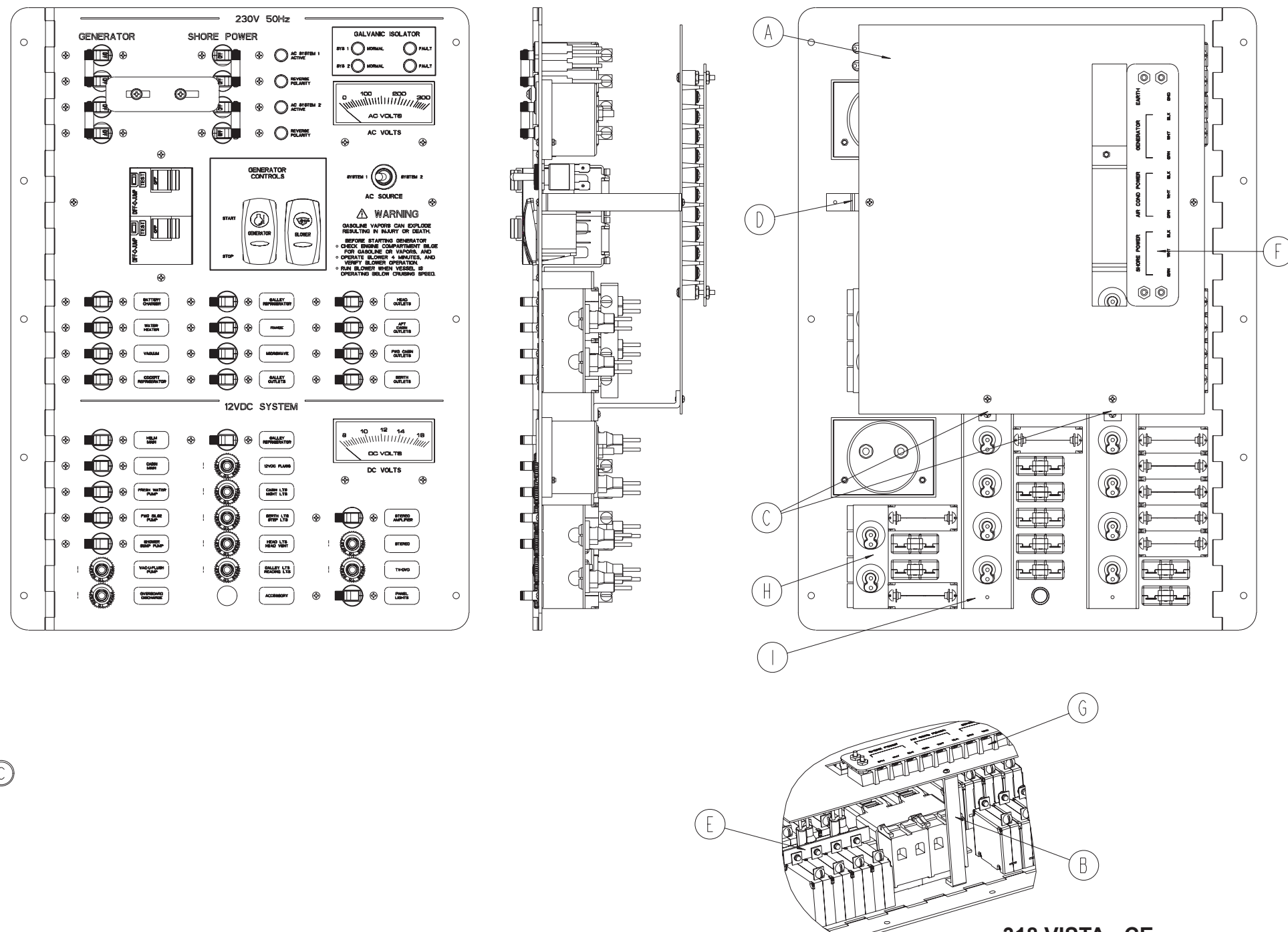

**318 VISTA - CE
AC/DC
PANEL ASSEMBLY
(1 of 4)**
Owner's Manual Page 215

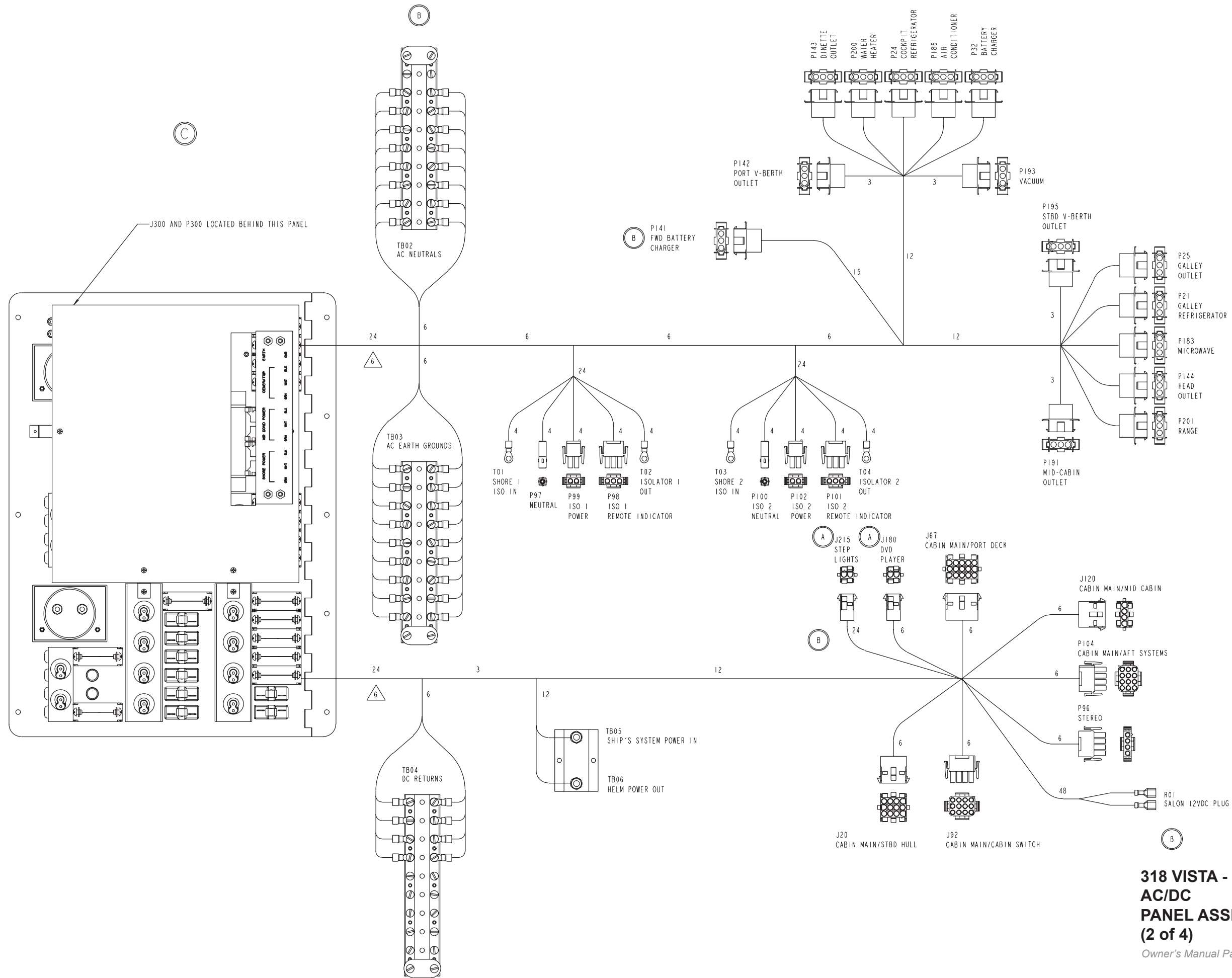

**318 VISTA - CE
AC/DC
PANEL ASSEMBLY
(2 of 4)**

Owner's Manual Page 216

HI VOLTAGE CIRCUITRY CE

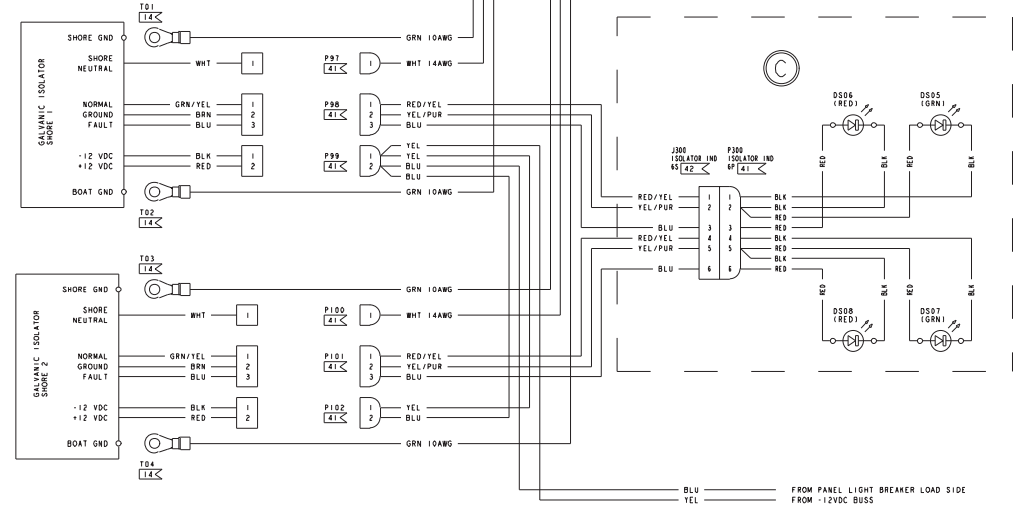
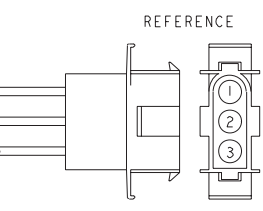
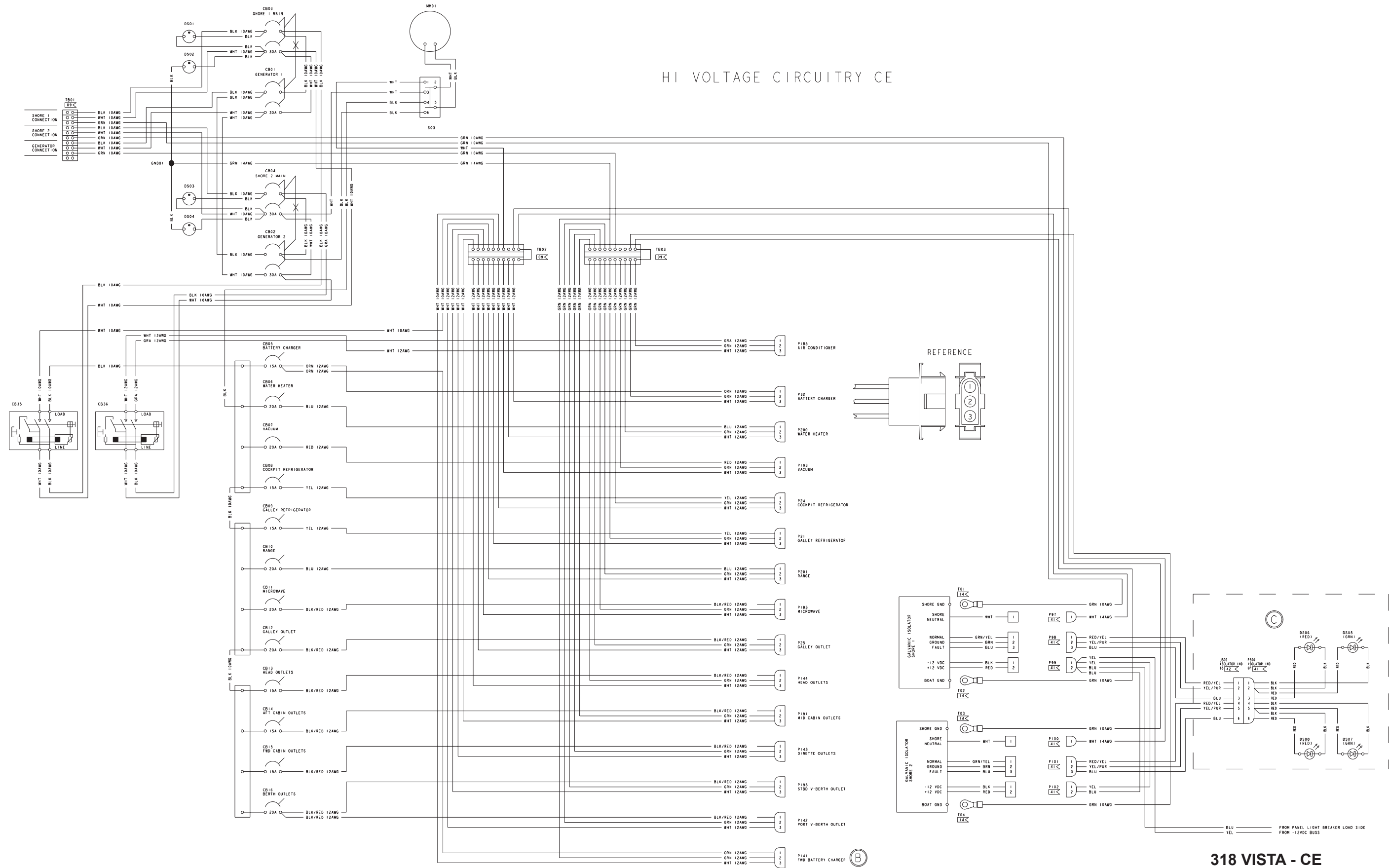

**318 VISTA - CE
AC/DC
PANEL ASSEMBLY
(4 of 4)**
Owner's Manual Page 218

025-3185
PANEL, BLANK AC INLET 348V '05

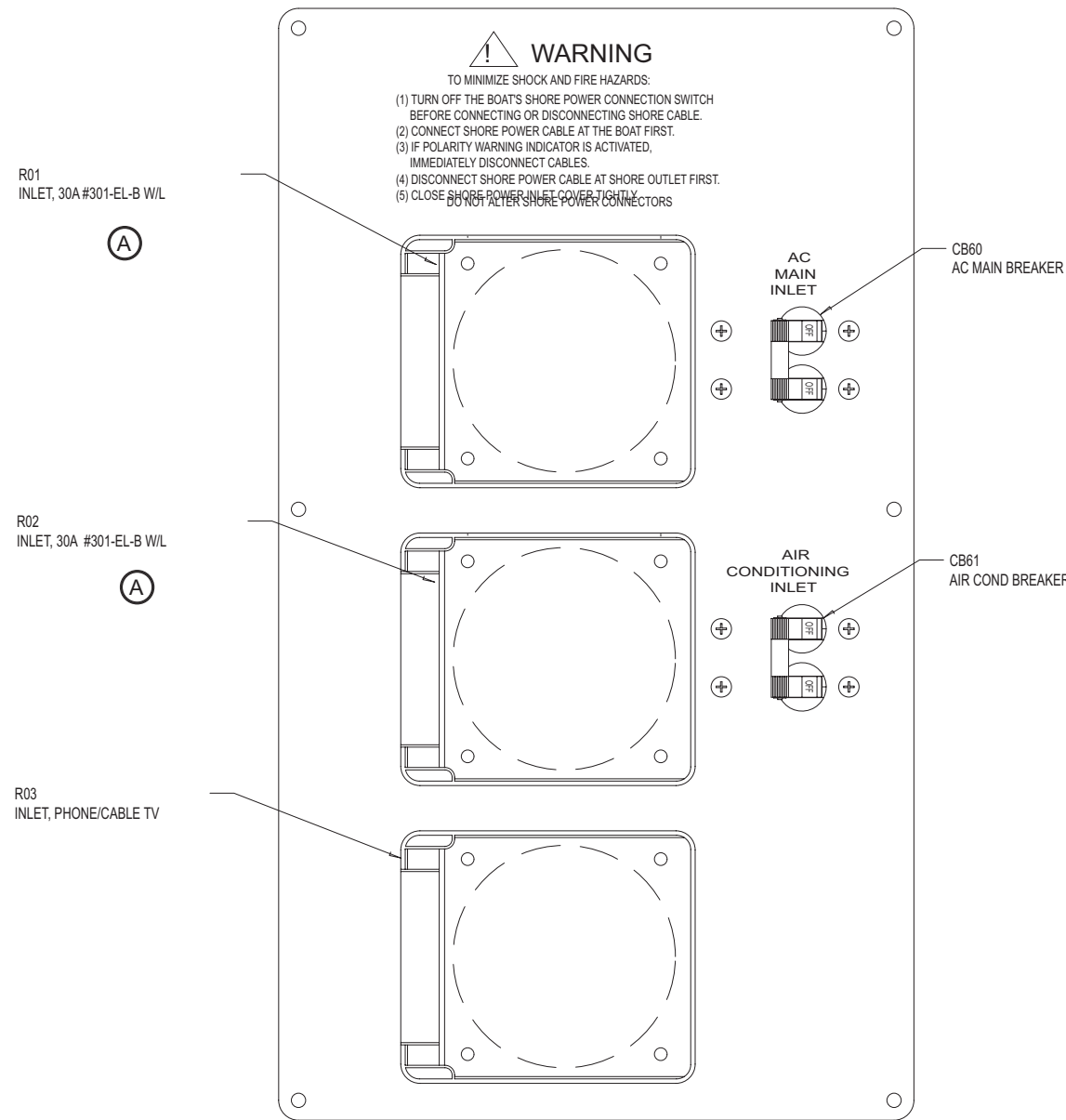

FRONT VIEW

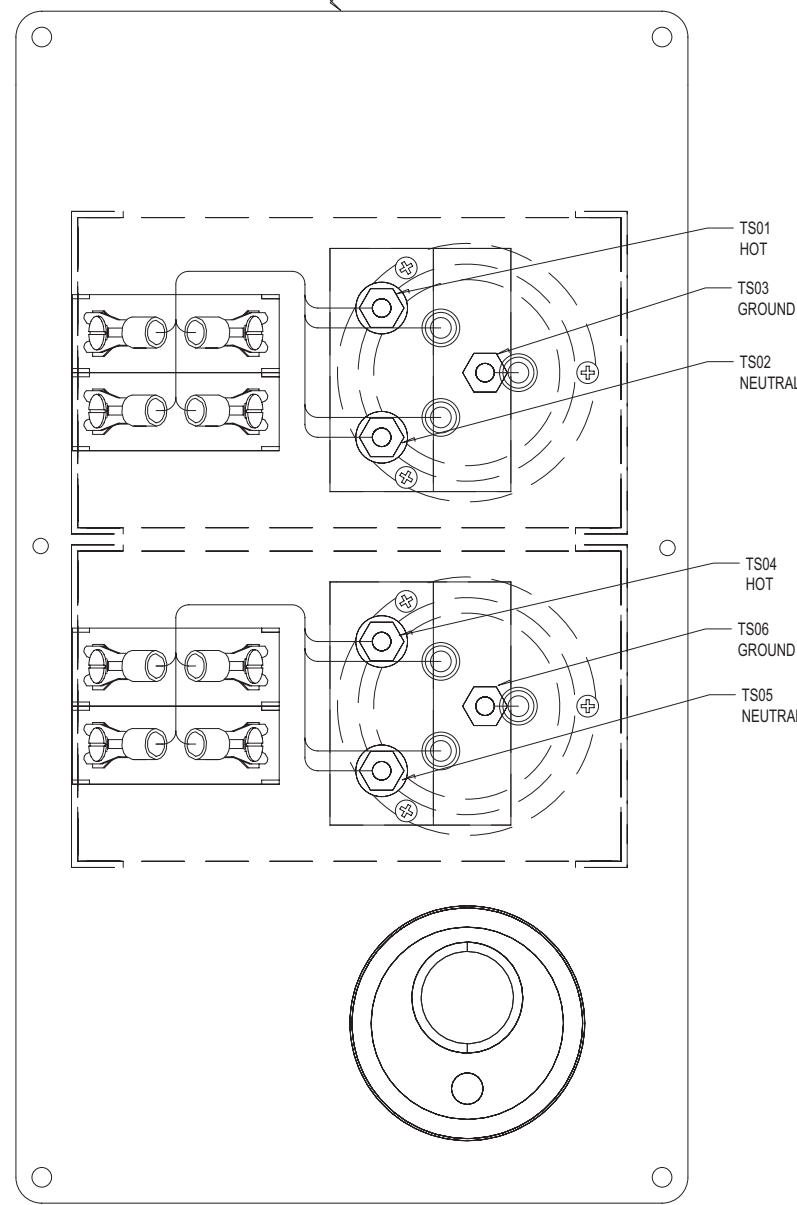

BACK VIEW

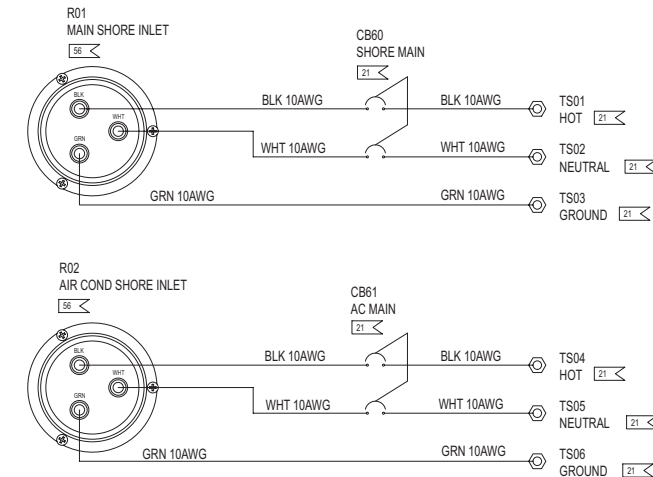

FOUR WINNS PARTS LIST

ITEM	PART NUMBER	QUANTITY	DESCRIPTION	FUNCTION	MANUFACTURER
-	028-0200	14	TERM,SS,#10,12-10	21	AMP
-	-	6	UNTERMINATED	56	AMP
PB01	025-3185	1	PANEL,BLANK,SHORE INLET	BLANK PANEL	-
CB60	028-0484	1	BREAKER,30A,DP	SHORE MAIN	CARL SW
CB61	028-0484	1	BREAKER,30A,DP	SHORE AIR COND	CARL SW
R01	065-0057	1	INLET,DOCKSIDE POWER	SHORE CONNECTOR	MARINCO
R02	065-0057	1	INLET,DOCKSIDE POWER	SHORE CONNECTOR	MARINCO
R03	065-1100	1	INLET,PHONE/TV PH6574TV.OEM	PHONE/TV	MARINCO
TS01	-	1	SCREW,#10-24 X 1/2", BRASS	SHORE MAIN HOT	-
TS02	-	1	SCREW,#10-24 X 1/2", BRASS	SHORE MAIN NEUTRAL	-
TS03	-	1	SCREW,#10-24 X 1/2", BRASS	SHORE MAIN GROUND	-
TS04	-	1	SCREW,#10-24 X 1/2", BRASS	SHORE AC HOT	-
TS05	-	1	SCREW,#10-24 X 1/2", BRASS	SHORE AC NEUTRAL	-
TS06	-	1	SCREW,#10-24 X 1/2", BRASS	SHORE AC GROUND	-

**318 VISTA
SHORE POWER / AC INLET
PANEL ASSEMBLY**

Owner's Manual Page 219

Shore Power Inlet Installation

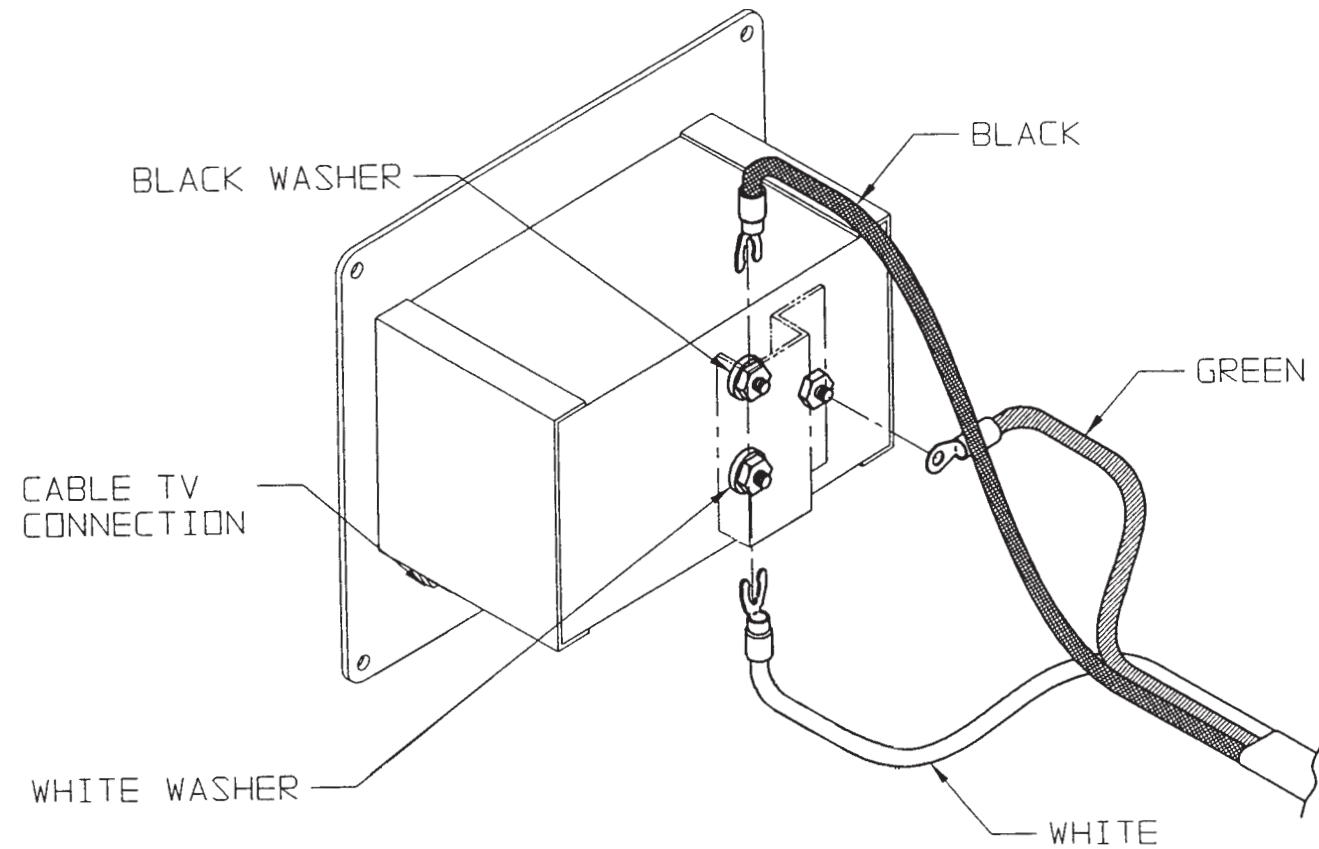

TYPICAL CONNECTION FOR SHORE POWER.

Galvanic Isolator Installation

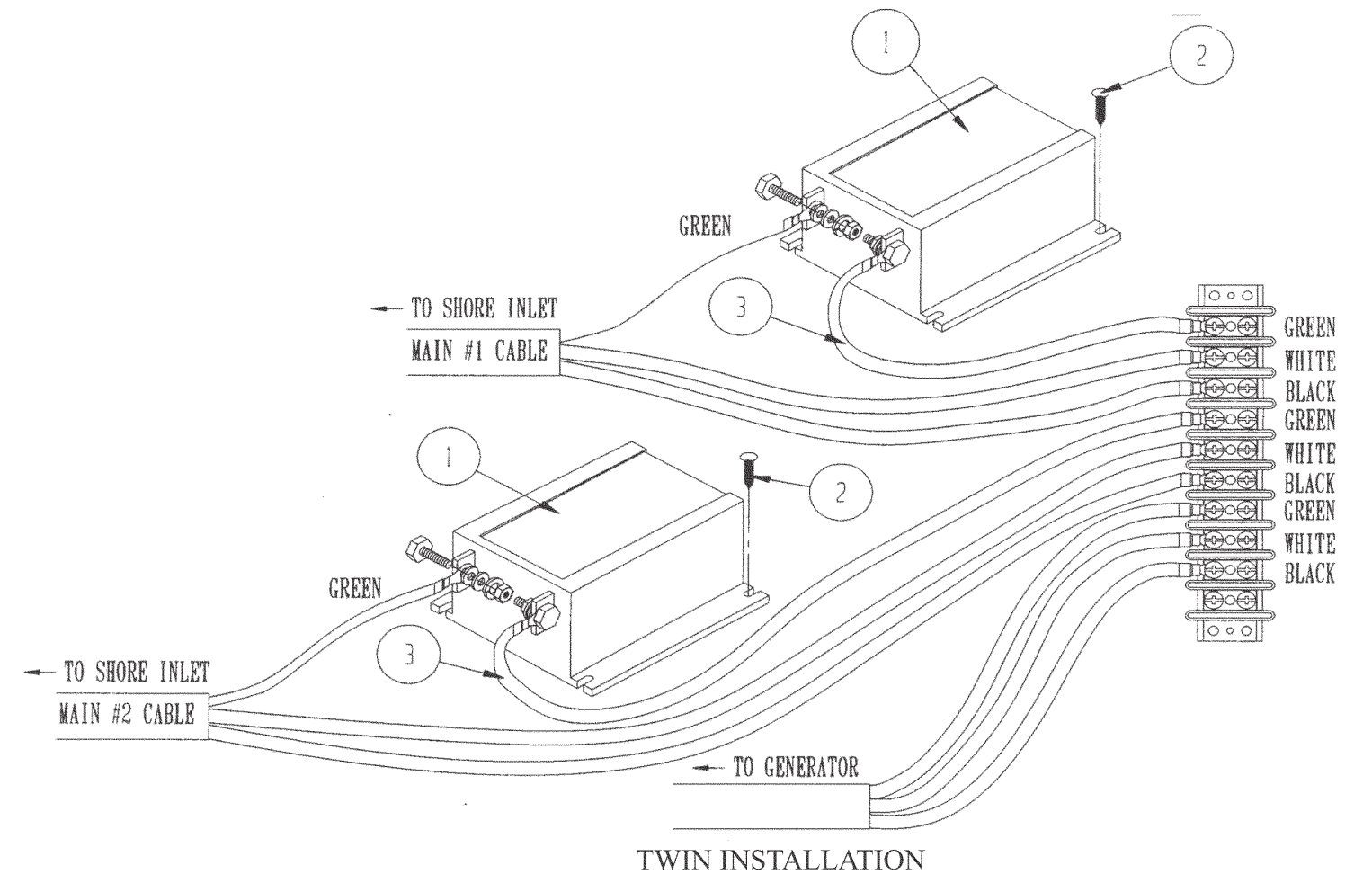

DESCRIPTION	PART #	QUANTITY (TWIN)
Galvanic Isolator, 30 Amp Guest #2433	028-1349	2 EA
Screw, #10 x 3/4" PTHSMS	080-0033	8 EA
Harness Assembly, Galvanic Isolator, 24"	027-1937	2 EA

SHORE POWER INLET & GALVANIC ISOLATOR INSTALLATION

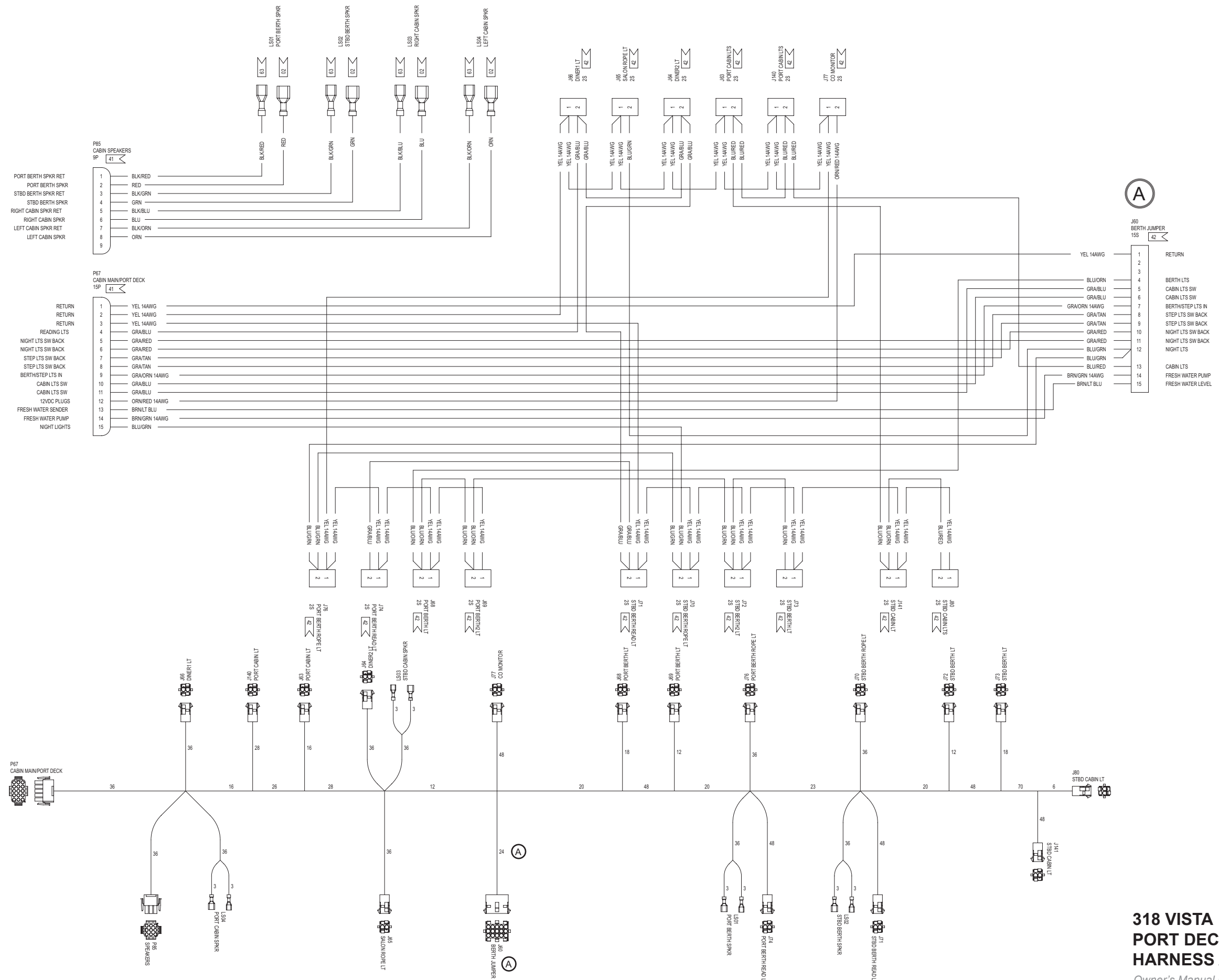

(A)

- 1 YEL 14AWG RETURN
- 2
- 3
- 4 BERTH LTS
- 5 CABIN LTS SW
- 6 CABIN LTS SW
- 7 GRA/ORN 14AWG
- 8 STEP LTS SW BACK
- 9 BERTHSTEP LTS IN
- 10 STEP LTS SW BACK
- 11 STEP LTS SW BACK
- 12 NIGHT LTS SW BACK
- 13 NIGHT LTS
- 14 CABIN LTS
- 15 FRESH WATER PUMP

**318 VISTA
PORT DECK
HARNESS ASSEMBLY**
Owner's Manual Page 221

FOUR WINNS PARTS LIST

ITEM	PART NUMBER	QUANTITY	DESCRIPTION	FUNCTION	MANUFACTURER
-	028-0177	4	TERM, FASTON, UF, 250, 16-14	02	AMP
-	028-0179	2	TERM, FASTON, UF, 250, 12-10	07	AMP
-	028-0390	7	PIN, UMNL, 16-14	41	AMP
-	028-0453	1	PIN, UMNL, 12-10	40	AMP
-	028-0454	5	SOCKET, UMNL, 18-14	42	AMP
-	028-0455	3	SOCKET, UMNL, 12-10	43	AMP
J78	028-0441	1	RECEPTACLE, UMNL, 2 CKT	WINDLASS	AMP
J81	028-0441	1	RECEPTACLE, UMNL, 2 CKT	HORN	AMP
P86	028-0449	1	PLUG, UMNL, 9 CKT	PORT SW PANEL B	AMP
J90	028-0441	1	RECEPTACLE, UMNL, 2 CKT	NAV LIGHT	AMP
J91	028-0441	1	RECEPTACLE, UMNL, 2 CKT	NAV LIGHT	AMP
WW02	-	REF	PORT WIPER	WIPER	AFI
WW01	-	REF	STBD WIPER	WIPER	AFI

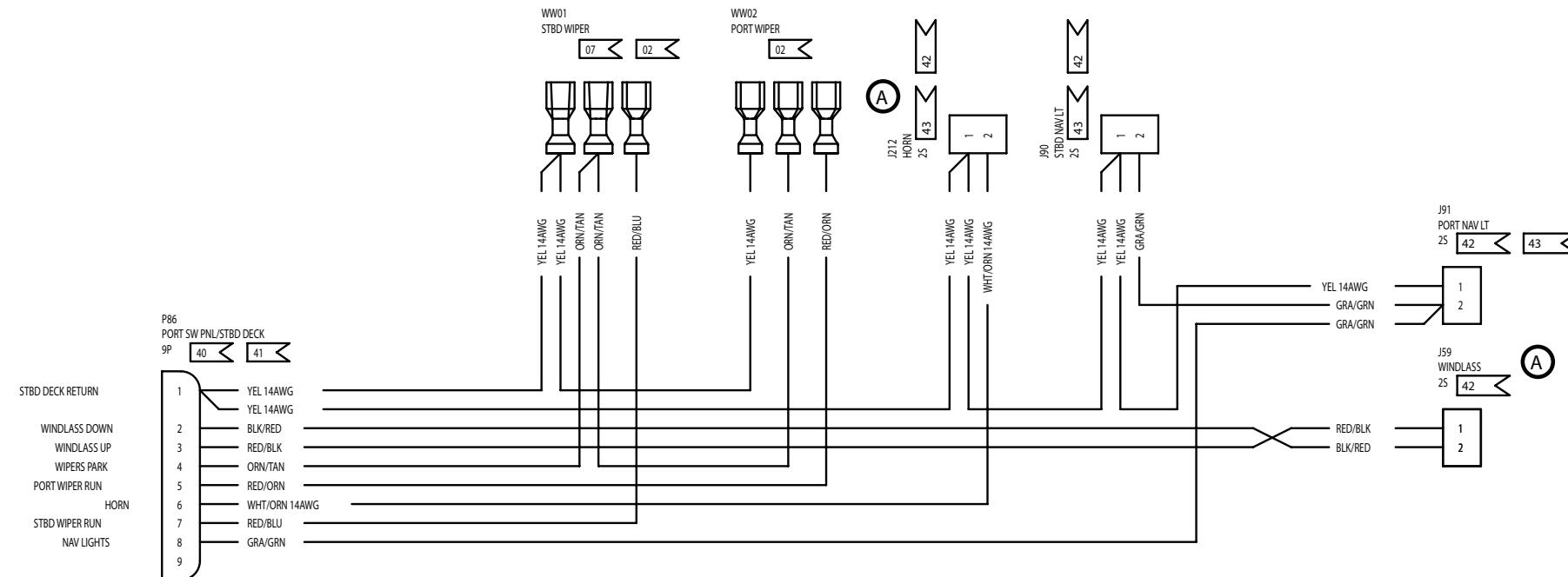
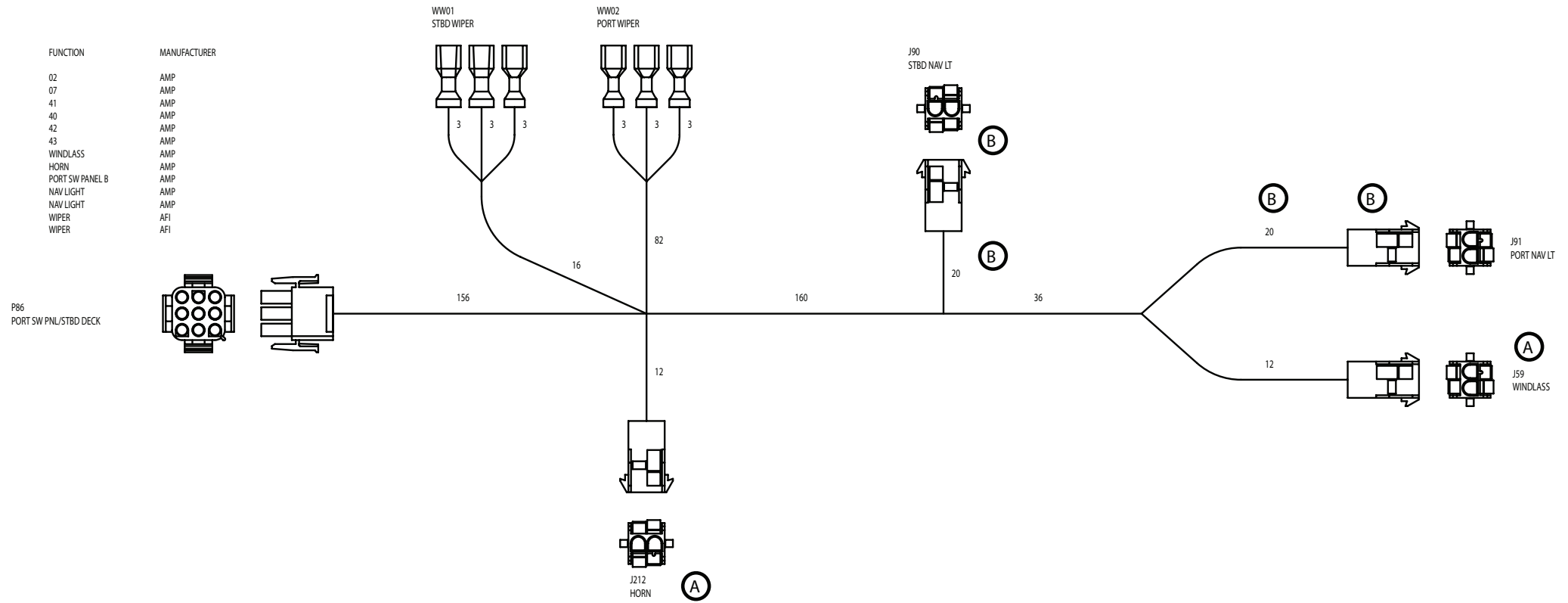

318 VISTA
STARBOARD DECK
HARNESS ASSEMBLY

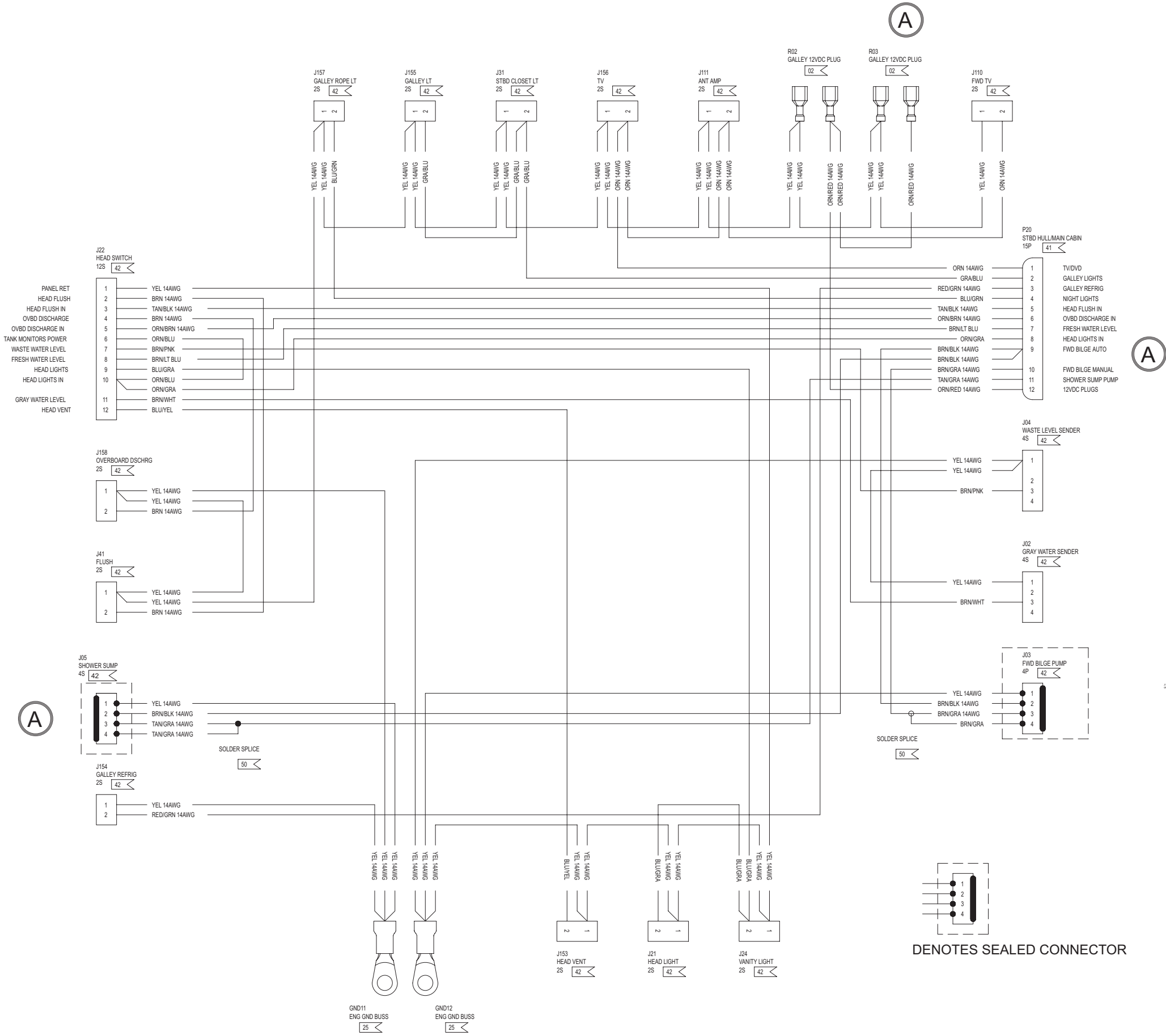

FOUR WINNS PARTS LIST

ITEM	PART NUMBER	QUANTITY	DESCRIPTION	FUNCTION	MANUFACTURER
-	028-0177	4	RECEPT, FASTON, 250,16-14	02	AMP
-	028-0390	12	PNLUMNL, 18-14	41	AMP
-	028-0194	42	SOCKET,UMNL, 18-14	42	AMP
-	028-0212	2	TERMRING,PG, 3/8", 8AWG	25	AMP
-	028-1771	1	SEAL,INTERFACE,UMNL,CKCT	-	AMP
-	028-1772	1	SEAL,WIRE,UMNL,2CKT	-	AMP
-	028-1913	1	SEAL,INTERFACE,UMNL,CKCT	-	AMP
-	028-1914	1	SEAL,WIRE,UMNL,4CKT	-	AMP
J02	028-0442	1	RECEPT,UMNL,4 CKT	GRAY WATER SNDR	AMP
J03	028-0442	1	RECEPT,UMNL,4 CKT	FWD BILGE PUMP	AMP
J04	028-0442	1	RECEPT,UMNL,4 CKT	WASTE LEVEL SENDER	AMP
J05	028-0442	1	RECEPT,UMNL,4 CKT	SHOWER SUMP PUMP	AMP
J21	028-0441	1	RECEPT,UMNL,2 CKT	HEAD LT	AMP
J22	028-0445	1	RECEPT,UMNL,12 CKT	HEAD SWITCH	AMP
J24	028-0441	1	RECEPT,UMNL,2 CKT	VANITY LT	AMP
J31	028-0441	1	RECEPT,UMNL,2 CKT	CLOSET LT	AMP
J41	028-0441	1	RECEPT,UMNL,2 CKT	VACUFLUSH	AMP
J110	028-0441	1	RECEPT,UMNL,2 CKT	FWD TV	AMP
J111	028-0441	1	RECEPT,UMNL,2 CKT	ANT AMP	AMP
J153	028-0441	1	RECEPT,UMNL,2 CKT	HEAD VENT	AMP
J154	028-0441	1	RECEPT,UMNL,2 CKT	GALLEY REFRIG	AMP
J155	028-0441	1	RECEPT,UMNL,2 CKT	GALLEY LT	AMP
J156	028-0441	1	RECEPT,UMNL,2 CKT	GALLEY TV	AMP
J157	028-0441	1	RECEPT,UMNL,2 CKT	GALLEY ROPE LT	AMP
J158	028-0441	1	RECEPT,UMNL,2 CKT	OVRSB DSOCHG	AMP
P20	028-0451	1	PLUG,UMNL,12 CKT	STBD HULL	AMP
R02	028-1100	REF	RECEPTACLE, 12V DC	GALLEY 12V PLUG	AFI

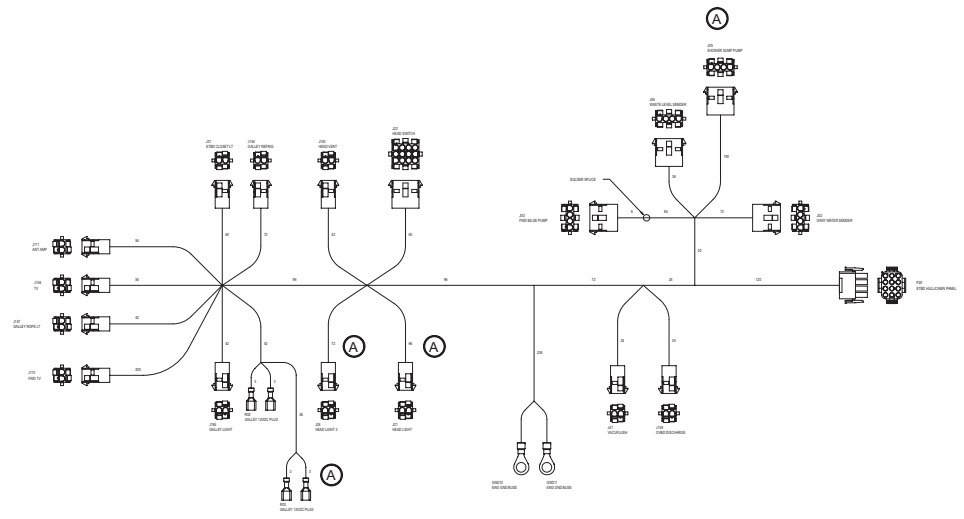

ⓐ DENOTES SEALED CONNECTOR

**318 VISTA
STARBOARD HULL
HARNESS ASSEMBLY**

Owner's Manual Page 223

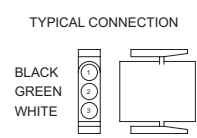
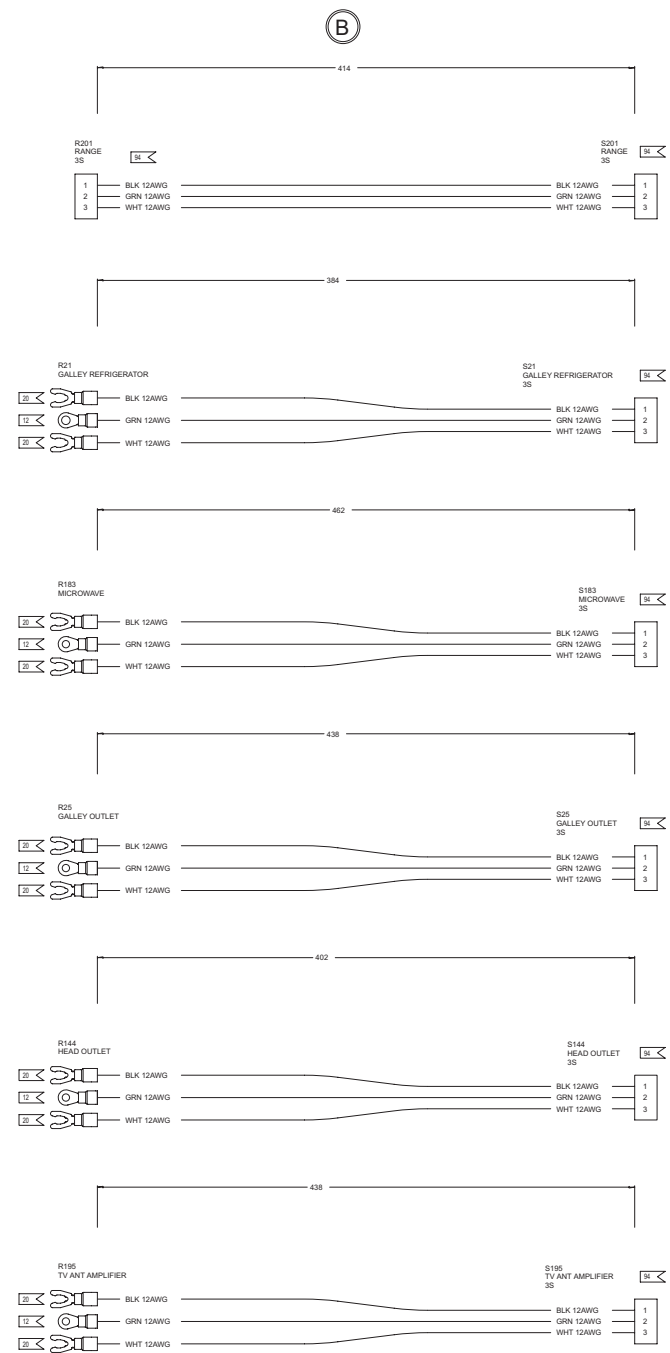
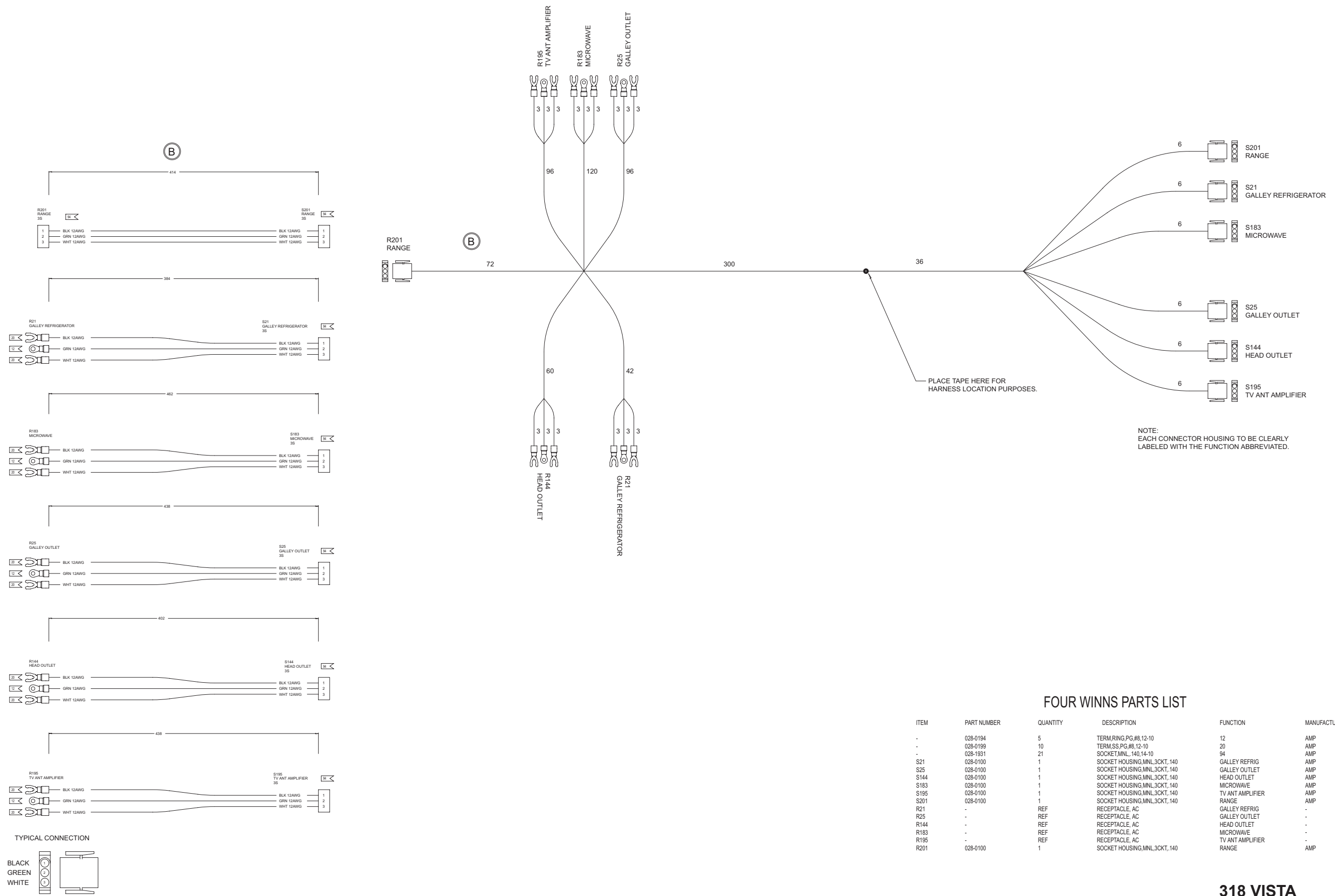

PLACE TAPE HERE FOR HARNESS LOCATION PURPOSES.

NOTE: EACH CONNECTOR HOUSING TO BE CLEARLY LABELED WITH THE FUNCTION ABBREVIATED.

FOUR WINNS PARTS LIST

ITEM	PART NUMBER	QUANTITY	DESCRIPTION	FUNCTION	MANUFACTURER
-	028-0194	5	TERM.RING.PG.#8,12-10	12	AMP
-	028-0199	10	TERM.SS.PG.#8,12-10	20	AMP
-	028-1931	21	SOCKET.MNL., 140,14-10	94	AMP
S21	028-0100	1	SOCKET HOUSING.MNL,3CKT.,140	GALLEY REFRIG	AMP
S25	028-0100	1	SOCKET HOUSING.MNL,3CKT.,140	GALLEY OUTLET	AMP
S144	028-0100	1	SOCKET HOUSING.MNL,3CKT.,140	HEAD OUTLET	AMP
S183	028-0100	1	SOCKET HOUSING.MNL,3CKT.,140	MICROWAVE	AMP
S195	028-0100	1	SOCKET HOUSING.MNL,3CKT.,140	TV ANT AMPLIFIER	AMP
S201	028-0100	1	SOCKET HOUSING.MNL,3CKT.,140	RANGE	AMP
R21	-	REF	RECEPTACLE, AC	GALLEY REFRIG	-
R25	-	REF	RECEPTACLE, AC	GALLEY OUTLET	-
R144	-	REF	RECEPTACLE, AC	HEAD OUTLET	-
R183	-	REF	RECEPTACLE, AC	MICROWAVE	-
R195	-	REF	RECEPTACLE, AC	TV ANT AMPLIFIER	-
R201	028-0100	1	SOCKET HOUSING.MNL,3CKT.,140	RANGE	AMP

318 VISTA
STARBOARD AC SYSTEMS
HARNESS ASSEMBLY

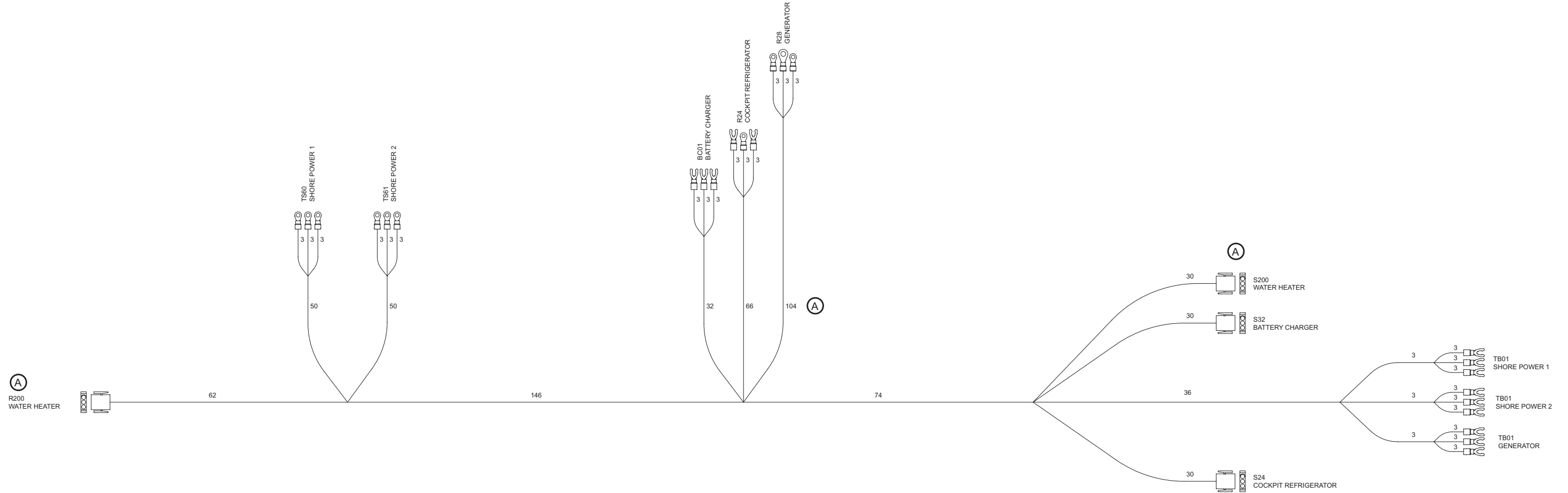

NOTE:
EACH CONNECTOR HOUSING TO BE CLEARLY
LABELED WITH THE FUNCTION ABBREVIATED.

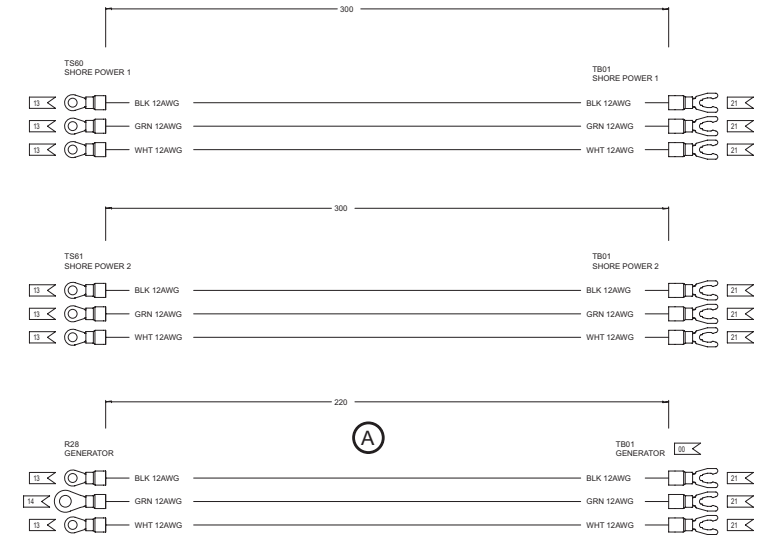
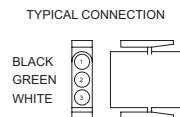
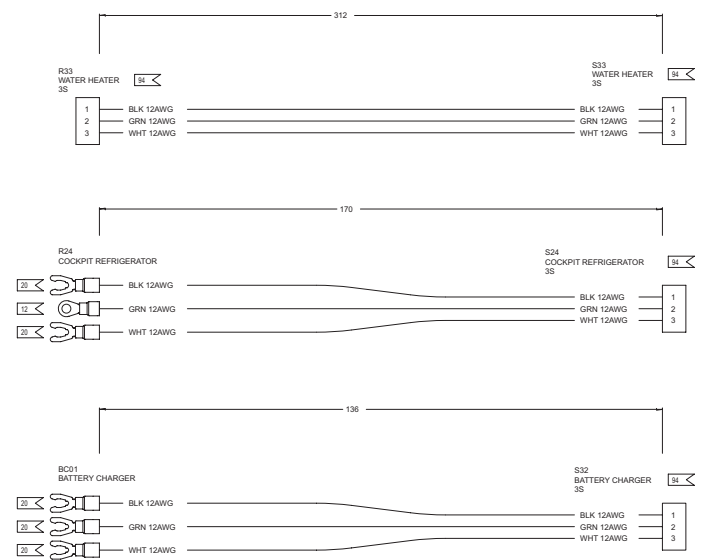

FOUR WINNS PARTS LIST

ITEM	PART NUMBER	QUANTITY	DESCRIPTION	FUNCTION	MANUFACTURER
-	028-0194	1	TERM.RING.PG.#8,12-10	12	AMP
-	028-0195	8	TERM.RING.PG.#10,12-10	13	AMP
-	028-0196	1	TERM.RING.PG.#14,12-10	14	AMP
-	028-0199	5	TERM.SS.PG.#8,12-10	20	AMP
-	028-0200	9	TERM.SS.PG.#10,12-10	21	AMP
-	028-1931	12	SOCKET.MNL.,140,14-10	94	AMP
S24	028-0100	1	SOCKET.HOUSING.MNL_3CKT.,140	COCKPIT REFRIG	AMP
S32	028-0100	1	SOCKET.HOUSING.MNL_3CKT.,140	BATTERY CHARGER	AMP
S33	028-0100	1	SOCKET.HOUSING.MNL_3CKT.,140	WATER HEATER	AMP
R24	-	REF	COCKPIT REFRIG.	COCKPIT REFRIG.	-
R28	-	REF	GENERATOR	GENERATOR	-
R33	028-0100	1	SOCKET.HOUSING.MNL_3CKT.,140	WATER HEATER	AMP
BC01	-	REF	BATTERY CHARGER	BATTERY CHARGER	-
TS60	-	REF	SHORE POWER INLET PANEL	SHORE POWER INLET PANEL	-
TS61	-	REF	SHORE POWER INLET PANEL	SHORE POWER INLET PANEL	-
TB01	-	REF	TERMINAL BLOCK	MAIN AC PANEL CONNECTION	-

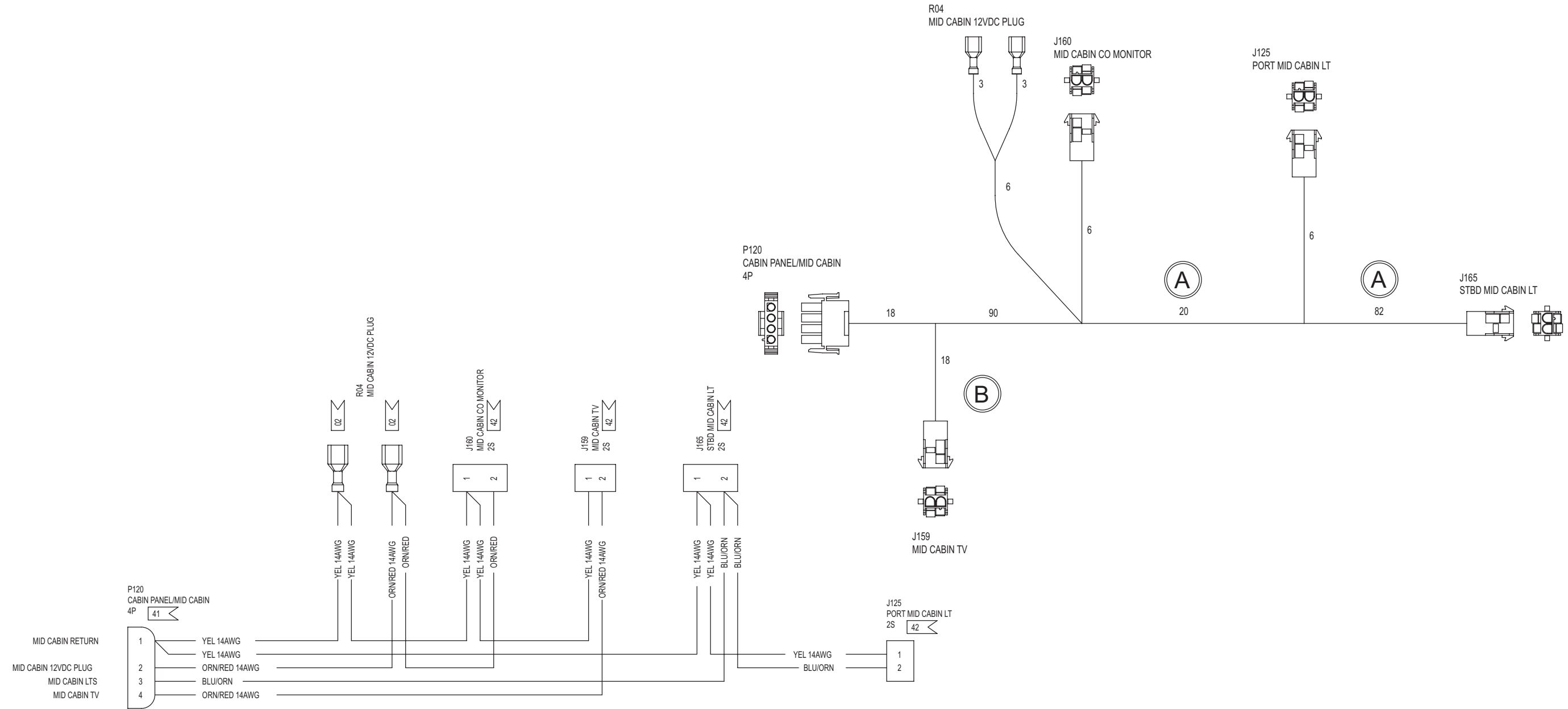

FOUR WINNS PARTS LIST

ITEM	PART NUMBER	QUANTITY	DESCRIPTION	FUNCTION	MANUFACTURER
-	028-0177	2	TERM.FASTON,UF,250,16-14	02	AMP
-	028-0390	4	PIN,UMNL, 18-14	41	AMP
-	028-0454	8	SOCKET,UMNL,18-14	42	AMP
P120	028-0448	1	PLUG,UMNL 4 CKT	CABIN PNL/MID CABIN	AMP
J125	028-0441	1	RECEPTACLE,UMNL 2 CKT	PORT MID CABIN LT	AMP
J159	028-0441	1	RECEPTACLE,UMNL 2 CKT	MID CABIN TV	AMP
J160	028-0441	1	RECEPTACLE,UMNL 2 CKT	MID CABIN CO MONITOR	AMP
J165	028-0441	1	RECEPTACLE,UMNL 2 CKT	STBD MID CABIN LT	AMP
R04	-	REF	12VDC PLUG	MID CABIN 12VDC PLUG	AMP

318 VISTA
MID CABIN
HARNESS ASSEMBLY

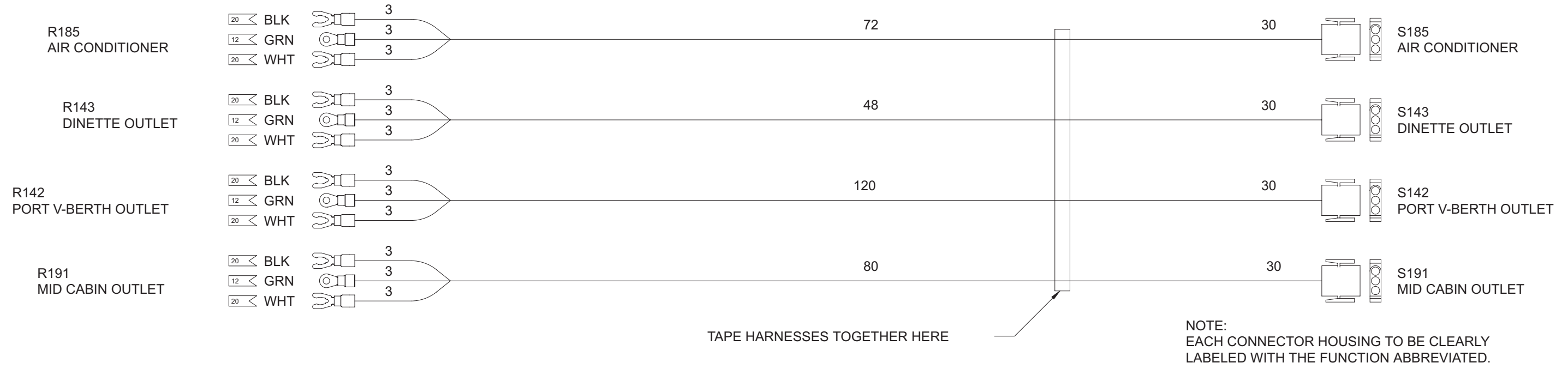

FOUR WINNS PARTS LIST

ITEM	PART NUMBER	QUANTITY	DESCRIPTION	FUNCTION	MANUFACTURER
-	028-0194	4	TERM,RING,PG,#8,12-10	12	AMP
-	028-0199	8	TERM,SS,PG,#8,12-10	20	AMP
-	028-1931	12	SOCKET,MNL,.140,14-10	94	AMP
S142	028-0100	1	SOCKET HOUSING,MNL,3CKT,.140	PORT V-BERTH OUTLET	AMP
S143	028-0100	1	SOCKET HOUSING,MNL,3CKT,.140	DINETTE OUTLET	AMP
S185	028-0100	1	SOCKET HOUSING,MNL,3CKT,.140	AIRCONDITIONER	AMP
S191	028-0100	1	SOCKET HOUSING,MNL,3CKT,.140	MID CABIN OUTLET	AMP
R142	-	REF	RECEPTACLE,AC	PORT V-BERTH OUTLET	-
R143	-	REF	RECEPTACLE,AC	DINETTE OUTLET	-
R185	-	REF	AIR CONDITIONER	AIR CONDITIONER	-
R191	-	REF	RECEPTACLE,AC	MID CABIN OUTLET	-

TYPICAL CONNECTION

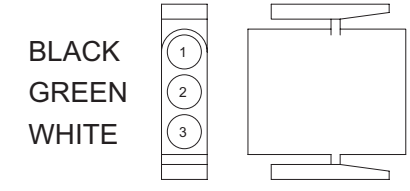

318 VISTA MID CABIN AC HARNESS ASSEMBLY

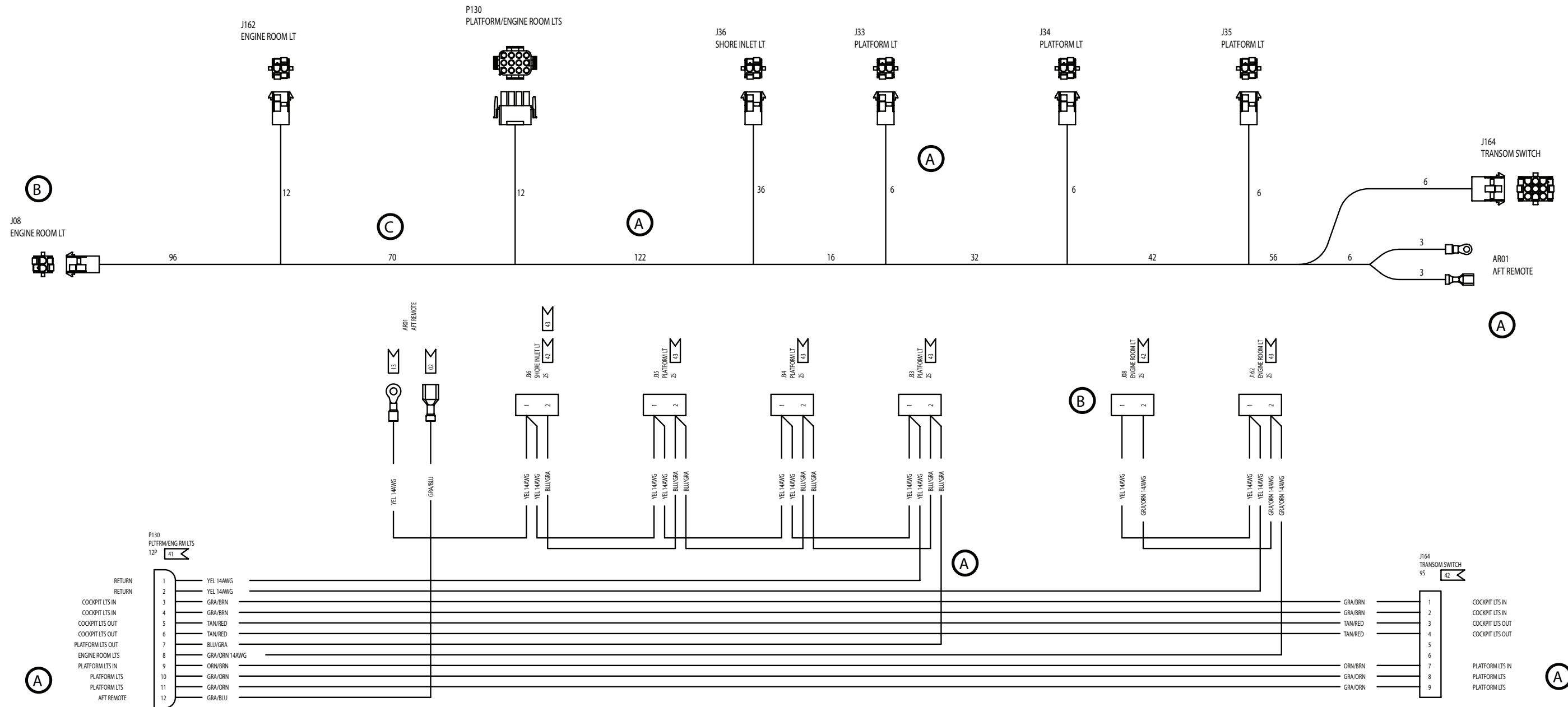

FOUR WINNS PARTS LIST

ITEM	PART NUMBER	QUANTITY	DESCRIPTION	FUNCTION	MANUFACTURER
-	028-0177	1	TERMINAL, FASTON, UF, 250, 16-14	02	AMP
-	028-0195	1	TERMINAL, RING, PG, #10, 12-10	13	AMP
-	028-0390	12	PIN, UMNL, 18-14	41	AMP
-	028-0454	10	SOCKET, UMNL, 18-14	42	AMP
-	028-0455	9	SOCKET, UMNL, 12-10	43	AMP
P130	028-0451	1	PLUG, UMNL, 12 CKT	PLATFORM/ENGINE ROOM LTS	AMP
J08	028-0441	1	RECEPT, UMNL, 2 CKT	ENGINE ROOM LT	AMP
J33	028-0441	1	RECEPT, UMNL, 2 CKT	PLATFORM LT	AMP
J34	028-0441	1	RECEPT, UMNL, 2 CKT	PLATFORM LT	AMP
J35	028-0441	1	RECEPT, UMNL, 2 CKT	PLATFORM LT	AMP
J36	028-0441	1	RECEPT, UMNL, 2 CKT	SHOREPOWER INLET LT	AMP
J162	028-0441	1	RECEPT, UMNL, 2 CKT	ENGINE ROOM LT	AMP
J164	028-0443	1	RECEPT, UMNL, 9 CKT	TRANSOM SWITCH	AMP
AR01	-	REF	-	AFT REMOTE	CLARION

318 VISTA
AFT DECK
HARNESS ASSEMBLY

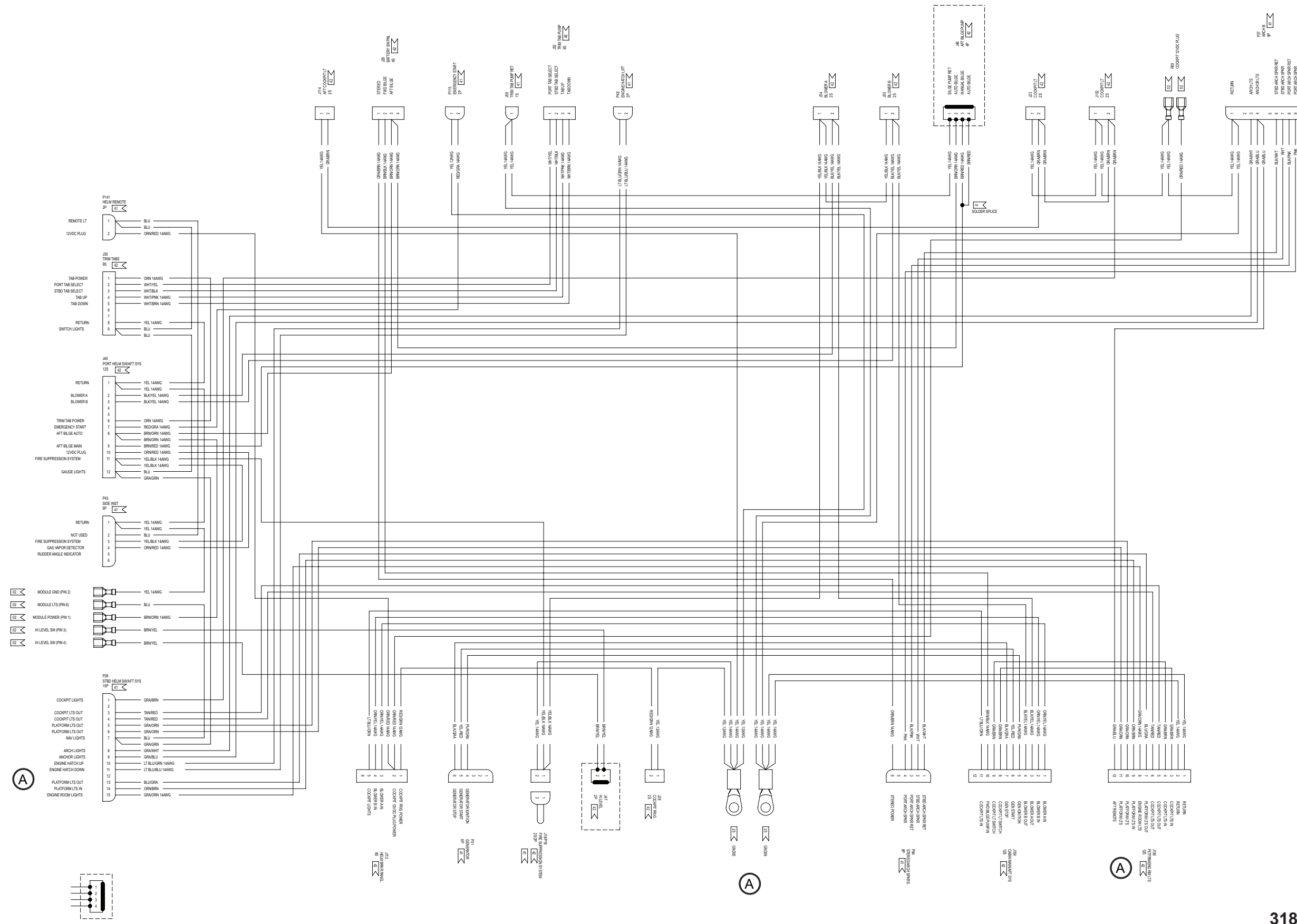

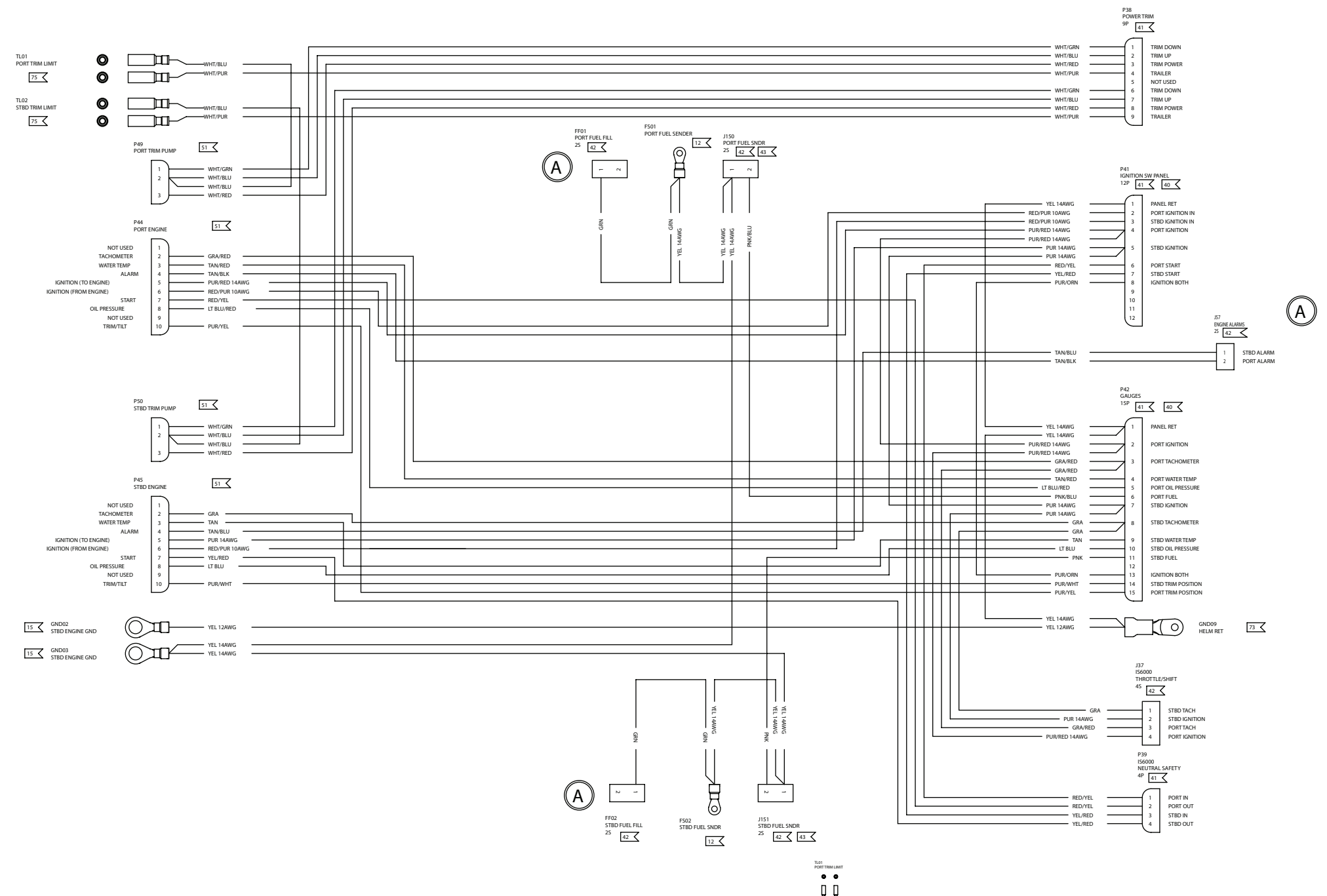

FOUR WINNS PARTS LIST

ITEM	PART NUMBER	QUANTITY	DESCRIPTION	FUNCTION	MANUFACTURER
-	028-0194	2	TERMINATING PG.#12-10	12	AMP
-	028-0197	2	TERMINATING PG.#12-10	15	AMP
-	028-0205	1	TERMINATING PG.#16	75	AMP
-	028-1823	4	TERMINAL LEEFEMALE, 156.16-14	75	AMP
-	028-0453	9	PLUG, 12-10	40	AMP
-	028-0290	25	PLUG, 18-14	41	AMP
-	028-0454	10	SOCKET, 18-14	42	AMP
-	028-0455	2	SOCKET, 12-10	43	AMP
-	-	22	WIRE, 22 AWG, 10 FT	51	AMP
237	028-0442	1	RECEPT, 4 CT	THROTTLE/SHIFT	AMP
257	028-0441	1	RECEPT, 2 CT	ENGINE ALARMS	AMP
319	028-0441	1	RECEPT, 2 CT	STBD FUEL SENDER	AMP
J151	028-0441	1	RECEPT, 2 CT	STBD FUEL SENDER	AMP
F38	028-0449	1	PLUG, 12-10 CT	POWER TRIM	AMP
P39	028-0448	1	PLUG, 12-10 CT	NEUTRAL SAFETY	AMP
P41	028-0451	1	PLUG, 12-10 CT	IGNITION SW PANEL	AMP
P42	028-0452	1	PLUG, 15-15 CT	GAUGES	AMP
P44	-	1	PLUG, ENGINE	PORT ENGINE PLUG	-
P45	-	1	PLUG, ENGINE	STBD ENGINE PLUG	-
P49	-	1	PLUG, TRIM	PORT TRIM PLUG	-
P50	-	1	PLUG, TRIM	STBD TRIM PLUG	-
F501	-	REF	FUEL LEVEL SENDER	PORT FUEL LEVEL	-
F502	-	REF	FUEL LEVEL SENDER	STBD FUEL LEVEL	-
FF01	028-0441	1	RECEPT, 12 CT	PORT FUEL FILL GND	AMP
FF02	028-0441	1	RECEPT, 12 CT	STBD FUEL FILL GND	AMP
GND1	-	REF	GROUND	PORT ENGINE GND	-
GND2	-	REF	GROUND	STBD ENGINE GND	-
GND3	-	REF	GROUND	STBD ENGINE GND	-
GND09	-	REF	GROUND	HELM GND	-

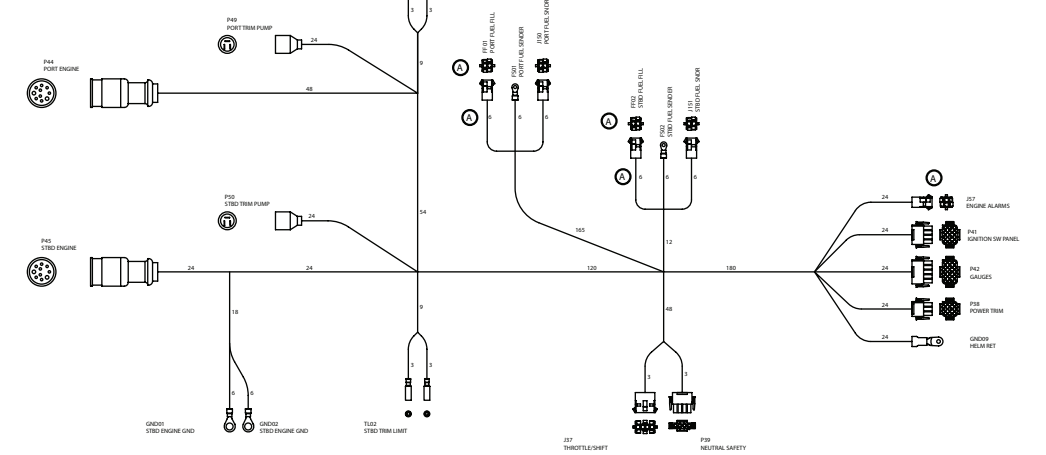

**318 VISTA
VOLVO ENGINE
HARNESS ASSEMBLY**
Owner's Manual Page 230

Navigational Aids Chart

REMEMBER THESE RULES

- OVERTAKING - PASSING:** Boat being passed has the right-of-way. **KEEP CLEAR.**
- MEETING HEAD ON:** Keep to the right.
- CROSSING:** Boat on right has the right-of-way. Slow down and permit boat to pass.

← **PORT**

STARBOARD →

Yield right-of-way to boats in your **DANGER ZONE!**

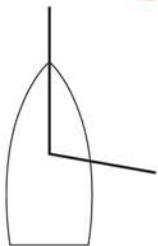

DANGER ZONE
(Dead ahead to 2 points abaft your starboard beam)

STORM WARNINGS



RED FLAG
Small craft (winds to 33 knots)



2 RED FLAGS
Gale (winds up to 47 knots)



SQUARE RED FLAG BLACK BOX
(Storm)



2 SQUARE RED FLAGS BLACK BOX
(Hurricane)

WHISTLE SIGNALS

ONE LONG BLAST: Warning signal

(Coming out of slip)

ONE SHORT BLAST: Pass on my port side

TWO SHORT BLASTS: Pass on my starboard side

THREE SHORT BLASTS: Engine(s) in reverse

FIVE OR MORE BLASTS: Danger signal

BRIDGE SIGNALS

SOUND

VESSEL: Open



BRIDGE: OK



No



VESSEL: Replies:



RADIO: VHF CH. 13

VISUAL

VESSEL: Open

DAY (Flag)

NIGHT (Lights)

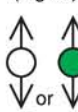
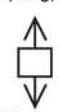

BRIDGE: OK

Same

Same

No



LATERAL AIDS AS SEEN ENTERING FROM SEAWARD

PORT SIDE

ODD NUMBERED AIDS

GREEN LIGHT ONLY

FLASHING

OCCULTING

QUICK FLASHING

ISOPHASE



LIGHTED BUOY

G "9"
Fl G 4sec



CAN

G "7"
C "7"



DAYMARK

G "1"
A "1"

SAFE WATER MID-CHANNELS OR FAIRWAYS

NO NUMBERS — MAY BE LETTERED

WHITE LIGHT ONLY MORSE CODE

Mo (A)



SPHERICAL



RW "G"
SP "G"



MR



RW "A"
A "A"



LIGHTED AND OR SOUND



RW "N"
Mo (A)

PREFERRED CHANNEL

COMPOSITE GROUP FLASHING (2 + 1)

GREEN LIGHT ONLY

RED LIGHT ONLY

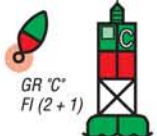

GR "C"
Fl (2 + 1)

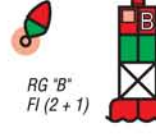

RG "B"
Fl (2 + 1)



CAN

PREFERRED CHANNEL TO STARBOARD TOPMOST BAND GREEN

GR "L"
C "L"



NUN

PREFERRED CHANNEL TO PORT TOPMOST BAND RED

RG "W"
N "W"



JG

GR "A"
A "A"



JR

RG "B"
B "B"

STARBOARD SIDE

EVEN NUMBERED AIDS

RED LIGHT ONLY

FLASHING

OCCULTING

QUICK FLASHING

ISOPHASE



LIGHTED BUOY

R "8"
Fl R 4sec



NUN

R "6"
N "6"



DAYMARK

R "2"
A "2"

 **FOUR WINNS**[®]

Genmar