

Four Winns

FOUR WINNS CATALOG
PRICELESS

1989 Boating Lifestyles



Building Boats
As If Our Future
Depended On It

2

New Class
In The Value Class

6



A Whole New Vista
In Trailerable Cruisers



30

Looking Nautically
Good



17

TEAM FOUR WINNS

Team Four Winns is an expression we use to acknowledge that delivering quality Four Winns boats is reliant upon individual commitment and effort by thousands of people... our own quality-conscious employees in our offices and plants in Michigan and Texas... the resourceful staff/production team of our supportive partner, Outboard Marine Corporation... the staffs and employees of our dedicated component and systems suppliers... the editors and test personnel of the boating press... and the sales representatives and service technicians of the consumer-minded professional marine retailers in our national dealer network.

Together, we're building and selling boats as if our future depended on it. The team concept forces us to communicate better and to respect the partnership roles we share in our pursuit of boating excellence.

The results, we are confident, will be self-evident in your review of the sportboats, deck boats, cuddys, cruisers, performance and fishing boats available for inspection at your Four Winns Dealer's showroom.

...Four Winns is America's fourth largest producer of fiberglass powerboats and we're one of the industry leaders in convenient and complete water-ready packages. All but two of our models 21-feet and under include a custom, color-matched Four Winns manufactured Sure Load™ trailer.

We're proud of our boats today. We back them with the strongest protection in boating... the exclusive *Winning Edge*™ 3-Year Owner Protection Plan. But as Team Four Winns, we know we have to provide even better boats... or you'll go looking for a better boat builder.



Safe Harbor U.S.A.

When we introduced *Winning Edge*™ 3-Year Protection as a standard feature on every Four Winns boat in 1987, we expected it wouldn't be long before other major boat manufacturers tried to match us...or even go us one better...

...We're still waiting.

We were the first to offer extended protection as an option in 1985. Because Team Four Winns is committed to "Building Boats As If Our Future Depended On It," we have the confidence to put our reputation on the line by providing coverage for all Four Winns buyers...at no extra cost. Three full years on Freedom™ and Horizon™ sportboats ...three full years on Candia™ deck boats ...three full years on affordable Sundowner™ cuddys ...three full years on live-aboard Vista cruisers ...three full years on Quest™ fishing boats... even three full years on high performance Liberator® models.

We've made the plan stronger in each of the three years since it became standard. This year, Four Winns exclusive *Winning Edge*™ 3-Year Owner Protection provides a one year limited warranty, plus two additional years coverage on:

- Hull and deck structural...including stringers, transom and floors.
- Fuel system.
- Electrical system and main wiring harness.
- Stereo system and speakers.
- Instrumentation includes depth sounder.
- Four Winns Sure Load™ trailers included in factory-shipped boat/motor/trailer packages.
- OMC Cobra® and other factory installed stern drive power systems including

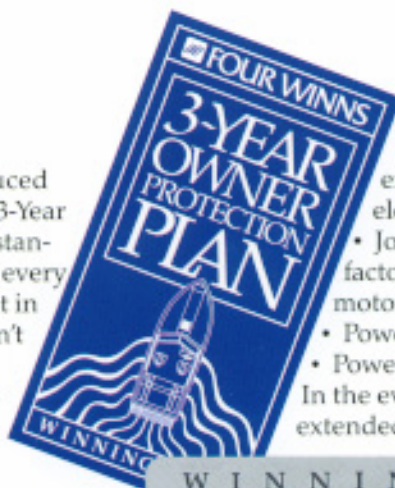

engine blocks, out drives, electrical and controls.

- Johnson® or Evinrude® factory pre-rigged boat/motor packages.
- Power steering.
- Power trim and tilt.

In the event of a claim on the extended protection portion of

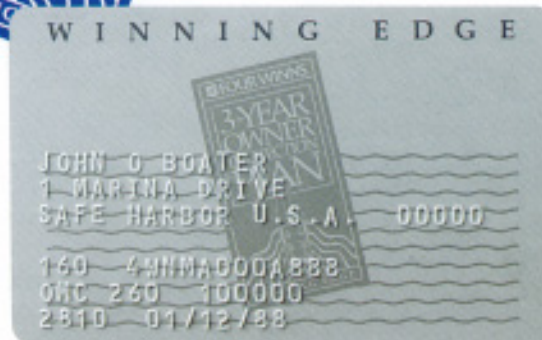

the program, the owner is only responsible for the first \$25 of service, and for returning the boat to any authorized Four Winns servicing dealer. All other costs for repairs and or parts on approved claims will be paid by Four Winns up to the cash value of the covered item. Parts installed on extended protection are warranted themselves for 90 days or the time remaining in the original 3-Year protection plan, whichever is longer. Should the replaced parts require further service, the \$25 service fee will be waived.

Unused portions of the *Winning Edge*™ Plan are transferrable when the original owner or subsequent owners sell the boat within the 3-year coverage period. To initiate a transfer all the new owner need do is provide Four Winns with a written request, a copy of the bill of sale, and a \$25 transfer fee.

The *Winning Edge*™ 3-Year Owner Protection Plan... it's the big edge Four Winns has over every other boat.

In November, aboard the cruise ship Dolphin, Team Four Winns-manufacturer, dealers and suppliers-renewed their commitment to "Building and Selling Boats as if Their Future Depended On it".

Four Winns



Four Winns boat owners share their favorite summer picnic menus.

10

New way to shop for bold, colorful, comfortable active wear to keep your family lookin' nautically good.

16

Top of the Dock

A contemporary, innovative new big water cuddy re-defines affordable family cruising.

26

Survival tactics for the fishing family.

38

Few sporting experiences can approach the thrill of skimming the water, tethered to a sleek, powerful sportboat.

40

WINN-GEAR

The care and feeding of fiberglass powerboats—protecting your investment.

22

Some sobering statistics about drinking and boating.

46

Design & Engineering	Page 2
Four Winns Sure Load™ Trailers	Page 5
Freedom®... New Class in the Value Class	Page 6
Horizon™... Great Shapes in Sportboating	Page 12
Candia™... Great Shapes in Deckboating	Page 18
Sundowner™... Affordable Family Cruising	Page 22
Vista... Trailerable Live Aboards	Page 28

An important note about the information in this catalog... Every effort has been made to insure that this catalog includes complete and accurate information. However, since the time of printing, some information may have been revised. Also, some equipment shown on Four Winns boats within this catalog is available at extra cost. Since we do reserve the right to make changes at any time, without

Vista... Wide Body Cruisers	Page 32
Quest Fishing™... Take it to Your Limit	Page 36
Liberator®... High Performance and Practicality Can Coexist	Page 40
Colors & Options	Page 48
Your Four Winns Professional Marine Retailer	Back Cover

notice, in prices, colors, equipment, specifications, and models, we suggest that you check with your Four Winns Dealer for complete and current information. OMC Cobra® OMC King Cobra® OMC Sea Drives® Johnson® Evinrude® and VRO™ are registered trademarks of Outboard Marine Corporation. *Four Winns/925 Frisbie St., Cadillac, MI 49601/(616) 775-1351

BUILDING BOATS AS IF OUR FUTURE DEPENDS ON IT.

Several years ago, we adopted the theme you see to your left as a mind-jogger to help everyone at Four Winns, and at all of our suppliers, focus on the importance of their assignment.

If you visit Team Four Winns at our plants in Cadillac, Michigan, or in Athens or Houston, Texas – and we hope you will consider this an invitation – you'll note the "Building Boats..." theme everywhere...



Full scale modeling helps us define interior content before models are built

on t-shirts and sweat-shirts... on plant posters... on note pads... on bumper stickers... on all of our product literature and official communiques... and, most evidently, in the spirit and vitality of the people in the trenches defining, designing and building Four Winns products.

Variations on a theme...

There are two interpretations of the "Building Boats..." theme. Both are important and fundamental to the Four Winns work ethic. First, it applies as a personal credo to remind everyone on Team Four Winns that the boat they're assembling... or the component they're designing... or the strategy they're defining at any given moment is integral with the continued success of Four Winns. Second, it reminds the Team Four Winns players that the good work being done today will not be good enough for



the future. This interpretation is particularly responsible for the controlled frenzy that grips the Four Winns design & engineering staff.

Not just boats... boat "families"

In our design center we are already applying the principles that will soon govern the engineering efforts of all boat manufacturers who wish to compete successfully in the changing marketplace.

We're in the second generation of the "family" design concept which

allows us to develop several boats from a single platform, sharing a common hull and running surface, stringer system and transom assembly, and allowing a high level of interchangeability among modular interior components.

The "200 family" represented by the popular 200 Horizon sportboat (p.14), 205 Sundowner cuddy (p.22) and 201 Liberator performance boat (p.40) was the first manifestation of the concept. Market differentiation was achieved through individual deck configurations, windshield

designs, feature content, color & graphics treatment and powerteam selections.

Our new 250 series represented by the 255 Sundowner cuddy (p.26), 255 Vista cruiser (p.30) and 251 Liberator performance boat (p.44) is an even more sophisticated example of "family" engineering principles.

Design commonality, shared componentry and parts interchangeability are the resources we're using to provide boats of ever-better quality, utility, performance and value.



In-water testing of prototype hulls at our Technical Center on Lake Cadillac allows us to refine running surfaces to meet target performance parameters.



Boat weight, ambient temperature and altitude above sea levels are factors considered when evaluating performance.



Bucket seats share a patented molded shell and pedestal, while cushioning and trim provide model differentiation.

Full scale line drawings and three-dimensional "bucks" are design tools of ergonomic engineering.



Final plugs are completed only after prototype evaluation.

WORKING HARD
TO MAKE BOATING
CONVENIENT,
SATISFYING AND
HASSLE FREE

This year, we'll produce a rather large number of advertisements to promote the Four Winns name. The number will be exactly equal to the rather large number of boats we'll produce.

Every boat that makes it through final assembly, gets shrink wrapped, nested on a carry-all, shipped to a Four Winns Professional Marine Retailer and delivered to an eager boater, has the potential to reach and impress – for better or worse – thousands of others who might also purchase a boat.

Looking at the boat building process from that point of view dramatizes the importance of

"Building Boats As If Our Future Depended On It." Obviously, our objective is far more important than simply building boats... we have to build happy boaters as well.

So we employ a number of programs to help us measure our performance and provide continuous improvement:

100% testing of electrical and fuel systems.

Statistical Process Control (SPC) to help us control the variables in the boat building process, cut down on scrap, minimize rework, and give the work station operator more control over his/her operation.



The *Quality audit index* lets us measure randomly selected boats daily at each of our plant locations against a pre-established standard of excellence. The audit team is comprised of Four Winns employees from all disciplines... production, engineering, purchasing, warranty, sales & marketing and other staff operations.

At our cruiser plant, where we manufacture Four Winns boats 24-feet and over, we've instituted a *full systems check* program that lets us ship boats that are water-ready, drastically reducing the "rigging" time required at the dealership. Each boat is floated in a test pool as it comes off the line. The engines, out drives and props are tested.

Hatches, seams, windshields and canvas are checked for water leaks. Air and water lines are pressure checked. Electrical systems, gauges, instruments, and stereos are all certified operational. Each boat is cleaned and inspected before being shrink wrapped for shipment to the Four Winns dealer and an eager new owner.



Custom fit and finish for canvas and upholstery is assured in our sewing shop.

Water-ready shipping of all Four Winns boats is a goal we'll soon realize at each of our production facilities.

It's a program we're counting on to make boating more convenient, satisfying and hassle free for our customers... and to make every finished product a strong advertisement for the quality, reliability, value and versatility of Four Winns boats.

Four Winns Sure Load™ trailers...

We maintain two trailer manufacturing facilities in proximity to our

boat building plants in Michigan and Texas to provide Four Winns Sure Load™ trailers for all Four Winns boats 21-feet and under. These are custom built trailers with tubular steel frames specifically designed to support each boat where the hull is strongest. Each is color-matched to the boat and features a removable tongue for easy garage storage. Galvanized trailers are available in saltwater regions. Building our own trailers makes perfect sense when you consider that more than 80% of all Four Winns production is comprised of smart, complete boat/motor/trailer packages.



"Storm" testing the 315 Vista for leaks



"Winning Edge", the final Four Winns mark of excellence.

Team Four Winns member at our Cruiser plant puts the finishing touches on a 245 Vista (top)... while one at our Cadillac, Michigan trailer facility completes a Four Winns Sure Load™ trailer (below).



Four Winns models 21 feet and under include a custom color-matched Four Winns Sure Load™

NEW CLASS IN THE VALUE CLASS



"Let's do something together" sets the tone of the day. Looking at maps, tracing scenic routes, planning the day ahead heightens the anticipation. Everything's set... the car's loaded... boat and trailer hitched to the back... time to roll!

Somehow, Mom's squeezed everything but munchies and napkins into the confines of a two handled insulated cooler.

The boat serves as extra storage space for the things

needed for a fun day on the water. Fishing gear, inflatables, skis and tow rope, personal flotation devices for every family member, dry changes of clothes, beach towels and other paraphernalia pack easily beneath the boat's canvas mooring or cockpit cover. Ahead are surprises that will turn this outing into a family conversation piece for years to come.

Few activities promote unity, sharing and camaraderie in the measure of boating. Today's boating families have a great luxury of choice. Thanks to the advent of boat/motor/trailer packages, getting into boating is more affordable and convenient than ever. Choosing a helpful professional marine retailer eliminates much of the hassle. With the abundance of public launch facilities available, most families are just minutes away from the boating lifestyle.



150 FREEDOM

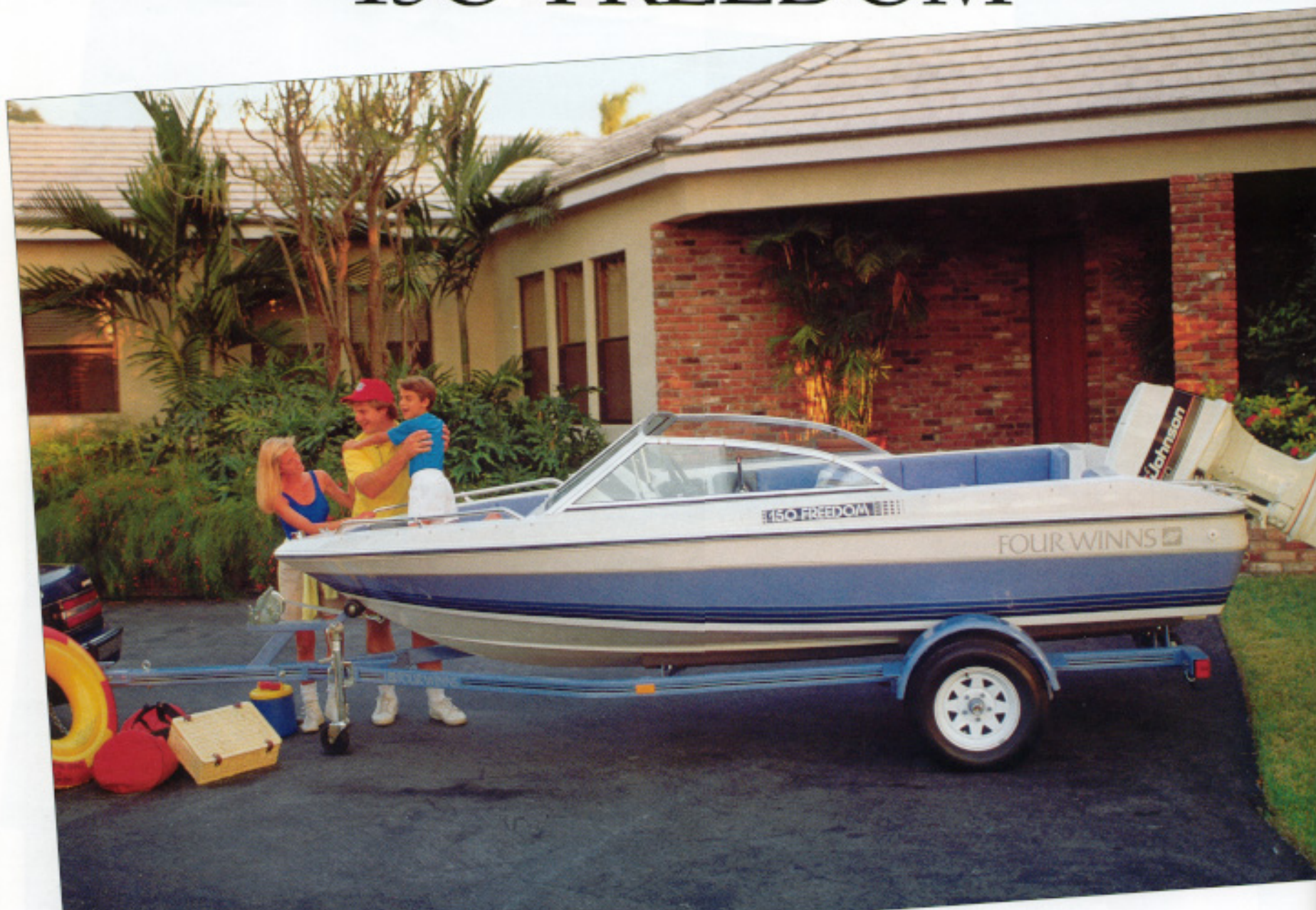

A boat is a great escape machine where time, pressure and stress can be put on hold... a place where family members can relax. Snorkel, fish, tube, kneeboard or ski.

Collect stones or driftwood. Share thoughts. Share solitude. Or do some slow-motion, roller-wave snoozing on rafts.

It's all available and free for the family that enjoys doing things together. Just turn the key, point the bow in the direction of fun and cast off. Best of all, it's all there to come back to... weekend after weekend.

This is where smart boating begins. The 150 Freedom™ is a stylish, fully equipped, five-passenger runabout priced within reach of nearly every family. The standard 48SPL Johnson® or Evinrude® outboard has plenty of muscle for family skiing, made easier by standard ski tow rings, in-floor ski storage and integrated swim platform with ladder.

AM/FM stereo cassette, full instrumentation, glove box, convertible top, a color-matched trailer, and plenty of sidewall and under bow seat storage make the 150 Freedom a strong candidate for value package of the year.



Standard stereo AM/FM cassette in weatherproof box.

Major Std Features

- Bow rails, stainless
- Cleats (3)
- Gel coat, two tone White/Red, White/Mariner
- Navigation lights
- Swim platform, fiberglass, integrated w/ladder
- Trailer, single axle, color-coordinated
- Windshield, tinted/tempered, with walk-through
- Color-coded wiring
- Emergency engine shut off
- Fused switches
- Instrumentation: tachometer; speedometer; voltmeter; fuel; trim indicator (60-HP only)
- Molded fuel tank (12 gal.)
- Steering wheel (padded)
- Stereo AM/FM cassette in weatherproof box
- Canvas top
- Carpeting
- Drain plug, brass
- Glove box
- Bilge, gel coat

- Seating: snap-in bow seats; back-to-back seats (folds to sleeper) adjustable driver's seat
- Storage: bow area
- Winning Edge™ 3-Year Owner Protection

Major Options

- Full canvas
- 60-HP Johnson® or Evinrude® outboard w/power trim & tilt, Vro™, trim indicator

For a complete list of standard and optional features ask your dealer for the 150 Freedom Feature Flyer

* Ask your Four Winns Dealer for full warranty details.



Standard color-matched Four Winns Sure Load™ trailer is designed for drive-on/drive-off ease and convenience.

Standard Seating

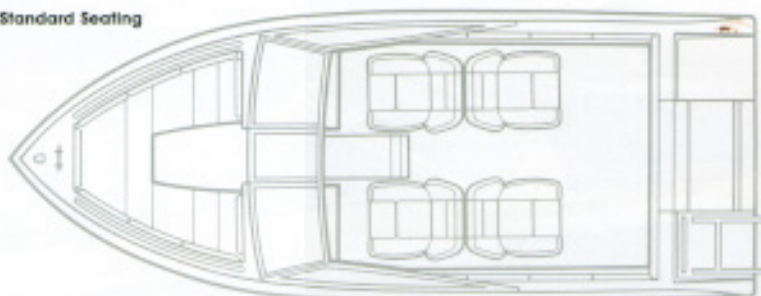

Specifications:

LOA:	15'2"
Beam:	7'2"
Boat Weight* (lbs.) w/48-HP OB:	1120
Fuel (gal.):	12
Power (HP):	OB 48, 60 (Johnson® or Evinrude®)
Passengers/Capacity (lbs.):	5/710
Keel to Windshield Height:	52"
Freeboard:	26"

*Boat weight based on design estimate



2.



1. Up to 60-HP of Johnson® or Evinrude® outboard available.
2. Integrated swim platform w/ladder and seating capacity for 5 add versatility to the 150.
3. Full instrumentation panel... reads at a



3.

NEW CLASS IN THE VALUE CLASS



Under floor ski storage.

"Relax...knees bent...sit back...tips out of the water...let the boat pull you up." "Easier said than done", says one who's never done it.

Yet, that's how everyone learns to waterski. You keep trying until it happens...and eventually it does. The first brief, shaky tour around the lake usually climaxes in an awkward face-first dismount. The neophyte quickly bobs to the surface beaming and sputtering, "Did you see me?..."



So begins for many a life-long dedication to a thrill-filled sport.

To the serious skier, a boat is more than water transportation...it's an integral component of a system supporting a unique lifestyle.

Skiing and boats first paired up in the late twenties when a kid from Minnesota strapped on home-builts, tied a rope to his parents Evinrude powered lapstrake, and yelled to his brother something on the order of "Now!".

The sport has grown exponentially since then in terms of both participation and sophistication.

Today's competition skiers circulate in a high-priced, high-tech world, speaking a tongue incomprehensible to the uninitiated. They seek break-through equipment designs that utilize exotic materials to gain a competitive edge.

Recreational skiers can shop specialty stores displaying a dazzling array of equipment, accessories and clothing, making it convenient for families to get into waterskiing at prices ranging from less than a hundred to several hundred dollars.

170 FREEDOM



All levels of ski enthusiasts should adhere to well-defined safe skiing guidelines:

- Ski in safe open water, away from swimmers, other boaters and underwater obstructions.
- Only let those who can swim ski.
- Insist that skiers wear a Coast Guard approved flotation vest.
- Have a "look out" in the boat so the driver can concentrate on the water ahead.
- Immediately assist downed skier.
- Approach downed skier from starboard and shut down power when near.
- Respect the rights of fishermen, swimmers and other boaters.

The new Freedom™ series brings never-before class to the value class. Elegant example: The 170 Freedom™



open or closed bow. A low silhouette, graceful sheer line, stylish integrated swim platform, and curved glass windshield are details common to boats priced

thousands more. You'll also appreciate the roomy, efficient and well-appointed interior... the lively performance and sure-footed stance of the deep-vee hull powered by

a 128-HP OMC Cobra® stern drive, or 90-HP Johnson® or Evinrude® outboard... and the convenience of a color-matched Four Winns Sure Load™ trailer with removable tongue for easy garaging. The classic design 160 Freedom is another Four Winns boat/motor/trailer entry in the value class.



160 Freedom, classic design.



170 Freedom Closed Bow with outboard.

170/170CB Major Std Features

- Rails, stainless
- Cleats (4)
- Gel coat, two tone White/Red, White/Mariner
- Ski eye (I/O)
- Swim platform, fiberglass integrated w/ladder
- Trailer, single axle, color-coordinated
- Windshield, tinted/tempered, with walk-through
- Bilge blower (I/O)
- Bilge, gel coat
- Emergency engine shut off
- Instrumentation (I/O): fuel; oil pressure; trim indicator; water temp.; speedometer; tachometer; voltmeter
- (OB): tachometer; speedometer; fuel; voltmeter; trim indicator
- Molded fuel tank (18 gal.)
- Power trim, tilt and VRO™ (OB)
- Power trim & tilt (I/O)
- Steering wheel (padded)

- Stereo AM/FM cassette in weatherproof box
- Carpeting
- Canvas top
- Drink holders (cockpit)
- Engine compartment insulation (I/O)
- Glove box
- Seating: hinged bow seats; back-to-back seats (folds to sleeper) adjustable driver's seat; jump seats remove or make sundeck (I/O)
- Storage: bow area, concealed top; floor (sk) (I/O)
- Winning Edge™ 3-Year Owner Protection*

Major Options

- Full canvas

For a complete list of standard and optional features ask your dealer for the 160 & 170 Freedom Feature Flyers

* Ask your Four Winns Dealer for full warranty details.



The 170 and all Freedom models are shipped as complete Boat/Motor/Trailer packages.

Open Bow Stern Drive

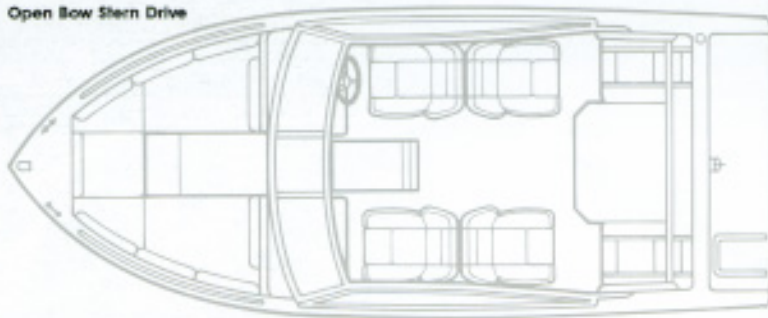

Closed Bow Outboard

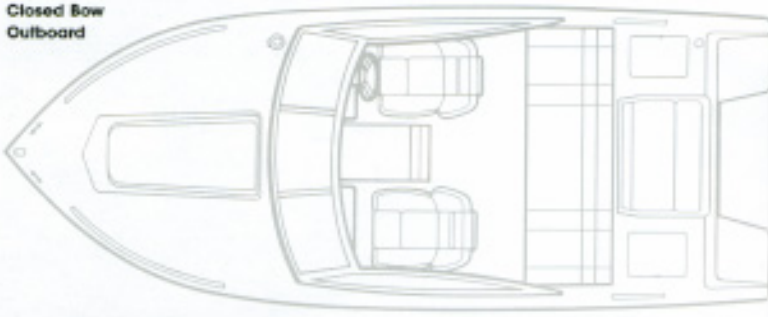

Specifications:	170-170CB	160
LOA/Transom to Bow:	16' 6" / 17' 1"	16'
Beam:	7' 3"	7' 2"
Boat Weight ¹ (lbs.) w/130-HP I/O:	2010/2070	2090
Boat Weight ¹ (lbs.) w/90-HP OB:	1670/1730	1760
Fuel (gal.):	18	19 I/O, 18 OB
Power (HP):	I/O 2.3L/128 OB 90"	I/O 3.0L/130 OB 90, 120
Passengers/ Capacity (lbs.):	OB 6/NA I/O 7/1000	6/850 7/1000
Keel to Windshield:	53"	59"
Freeboard:	29"	28"

¹Johnson® or Evinrude®
²Boat weight based on design estimate
NA = Not Available



1. The spirited 170 is available with 128-HP OMC Cobra® stern drive or Johnson® or Evinrude® 90-HP outboard.

2. Conveniently placed steps provide easy entry/exit to and from the bow.

3. Direct steering

NEW CLASS IN THE VALUE CLASS



Freedom is an affordable new way to join the boating lifestyle.

"Summertime... an' the livin' is easy", penned Gershwin's lyricist for the *Porgy and Bess* classic. Perhaps he was inspired by images of a halcyon picnic on a quiet beach accessed only by boat. A private place where a family feasts...and laughs...and shares. Offshore, another family - of



Kingfishers - circles with purpose, planning a feast of their own in the warm shallows below.

The family boating picnic is a scene played umpteenth times a summer on beaches and land-falls across America. The meal can run the gamut from light fare to a multi-course take-a-nap-later feast.

Here are a couple of favorites from the files of the Four Winns Boat Owner's Association.

The Great Lakes Traditional Picnic

- Fried chicken
- Potato salad
- Beans & franks
- Corn on the cob
- Chips/veggies & dip
- Cole slaw
- Biscuits or rolls
- Pink lemonade
- Apple pie ala mode
- Watermelon

The Cape Cod Classic Picnic

- Salmon steaks with lemony mayonnaise
- Steamed clams
- Creamy fish chowder
- Seafood pasta
- Steamed peas w/chives
- Sliced cucumbers
- Breadsticks
- Spiced ice tea
- Chocolate truffles

190/195 FREEDOM



Prepare food at home, wrap finger-foods in aluminum foil, store soups and salads in plastic bowls with sealed lids or covered cook pots. Place beverage and perishables in insulated coolers with plenty of ice. Pack napkins, tablecloth, flatware, salt & pepper, condiments, toothpicks, and paper plates/cups/bowls separately. Bring along matches and a portable grill to heat main menu items. Don't forget a large plastic rubbish bag so you can remove left-overs and discards when you leave.

To make it easier for growing families to stay in the value class, Four Winns has added an affordable 190 Freedom™ sportboat and 195 Freedom cuddy. Both are roomy, comfortable and complete with weather-protected AM/FM stereo cassette, full instrumentation, ski tow, in-floor teak lidded ski storage, glovebox, padded steering, and color-coordinated trailer...both provide



Affordable 195 Freedom cuddy has vee-berth for two.

spirited performance from either a 175-HP OMC Cobra® stern drive or a 120-HP Johnson® or Evinrude® outboard...and, like all Four Winns boats, both include exclusive Winning Edge™ 3-year Owner Protection*...boating's strongest coverage.

Major Std Features

- Rails, stainless
- Cleats (4)
- Gel coat, two tone White/Red, White/Mariner
- Ski eye (I/O)
- Swim platform, fiberglass, integrated w/ladder
- Windshield, tinted/tempered, with walk-through
- Bilge blower (I/O)
- Trailer, single axle, color-coordinated
- Emergency engine shut off
- Instrumentation (I/O): fuel; oil pressure; trim indicator; water temp.; speedometer; tachometer; volt-meter; (OB); tachometer; speedometer; fuel; voltmeter; trim indicator
- Molded fuel tank (24 gal.)
- Power steering, (I/O)
- Power trim, tilt and VRO™ (OB)
- Power trim, tilt (I/O)
- Steering wheel (padded)
- Bilge, gel coat

- Stereo AM/FM cassette in weather-proof box
- Canvas top
- Carpeting
- Drink holders (cockpit)
- Engine compartment insulation (I/O)
- Glove box
- Seating: hinged bow seats; back-to-back seats (folds to sleeper) adjustable driver's seat; jump seats remove or make sundeck (I/O)
- Storage: bow area; concealed top (I/O) floor (ski)
- Winning Edge™ 3-Year Owner Protection*

Major Options

- Full canvas

For a complete list of standard and optional features ask your dealer for the 190 & 195 Freedom Feature Flyers

* Ask your Four Winns Dealer for full warranty details.

OMC Cobra® 175-HP stern drive is standard.



Standard Seating (190)

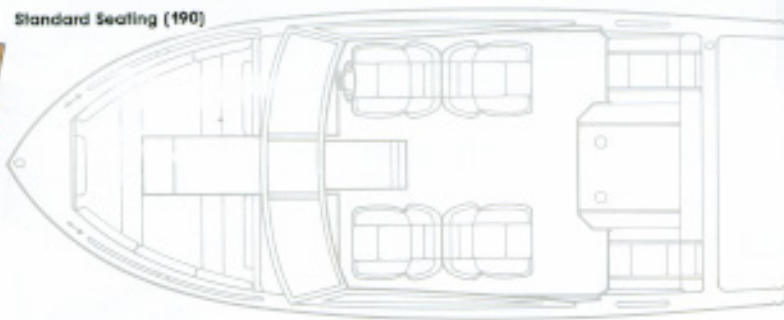

Cabin Interior (195)

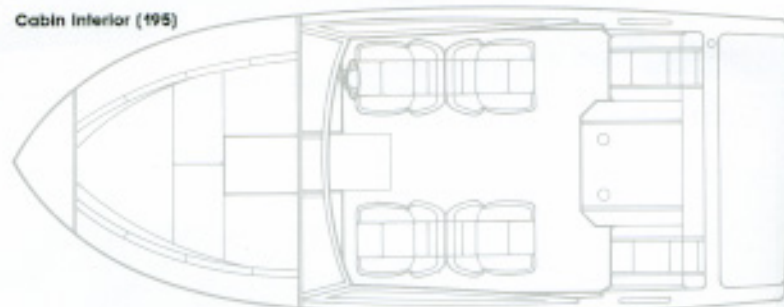

Specifications:	190	195
LOA/Transom to Bow:	19'8"/18'2"	19'8"/18'2"
Beam:	7'3"	7'3"
Boat Weight ¹ (lbs.) w/175-HP I/O:	2240	2330
Boat Weight ¹ (lbs.) w/120-HP OB:	1820	1910
Fuel (gal.):	24	32
Power (HP):	I/O 4.3L/175 OB 120TL ¹	I/O 4.3L/175 OB 120 ¹
Pkgs/Capacity (lbs.):	OB 7/NA I/O 8/1085	7/NA 8/NA
Keel to Windshield:	53"	68"
Freeboard:	29"	33"

¹ Boat weight based on design estimate
¹ Johnson® or Evinrude®
 NA = Not Available



1. Adjustable seating, swim platform with ladder, and sundeck (I/O) add to Freedom's versatility.

2. Plenty of sidewall storage.

3. Full instrumentation is a unique design to



GREAT SHAPE IN SPORTBOATING



Standard stereo
AM/FM cassette w/
weatherband.

Triathlon fever has gripped the populace...young and old...male and female...professional and amateur. Thousands of hours of training and sacrifice have prepared these committed athletes for a test that many argue humans are simply not anatomically equipped for.

We talk about the triathlon here for two reasons. The most obvious is that the first leg of every triathlon begins in the water. The other is that the triathlon athlete is the supreme roll model for fitness enthusiasts...many of whom are found among the ranks of those pursuing a vigorous and active boating lifestyle.

The triathlon was the brainchild of Navy Commander John Collins

Bike stage in the
Iron Man/Woman
Triathlon is a
torturous 112 miles.



and friends while stationed in Hawaii during the 70's. The Honolulu fun-runs they participated in no longer provided enough challenge for their fitness level. So they conceived the grueling "Iron Man/Woman" contest...an event they believed would challenge the limits of physical capability.

In it's basic form, a triathlon consists of three legs...swimming, biking and running.

The shortest and most popular version is called a "sprint". Competitors swim up to a half mile, bike 18 to 20 miles, and finish with a 5K run. Top athletes finish in about an hour and a quarter.

180 HORIZON



The "marathon" triathlon has been standardized as a one-mile swim, a 25-mile bike stage, and a 10K run. First contestants hit the tape in about two hours.

The original and most famous version, the "Iron Man/Woman" competition, started by Commander Collins and friends in 1977, consists of a 2.4-mile ocean swim, a 112-mile bike ride, and a 26.2-mile run. The winning time in that first competition was 11 hours, 46 minutes. Amazing!

The triathlon, it's the ultimate expression of an active lifestyle... that begins, fittingly, in the water.

The sporty 180 Horizon™ provides more of the features and amenities discriminating sportboat buyers request. More style, convenience and comfort... more interior space...

phenomenal storage. The standard features roster goes on and on... power steering (I/O), power trim & tilt, ski eye, in-floor ski storage, bow anchor

locker, integrated cooler, color-matched trailer, AM/FM stereo cassette with weatherband, even an ingenious antenna that suppresses AM interference. Power ranges from 175- or 200-HP stern drives to 120- or 150-HP outboards.

Now there's new value available from the great shape in sportboating... a stylish and sensible 180 Horizon Convertible™ featuring a closed bow with hinged center panel that lifts to access a huge lockable storage area.

Major Std Features

- Anchor locker, bow
- Bilge, auto pump
- Closed bow w/hinged center entry (Convertible only)
- Rails, stainless
- Cleats (4)
- Gel coat, two tone
- Ski eye, stainless (I/O)
- Swim platform, fiberglass integrated with ladder
- Trailer, single axle, color-coordinated
- Windshield, tinted/tempered, bent glass with walk-through
- AM/FM antenna w/noise suppressor
- Bilge blower (I/O)
- Bilge, gel coat
- Emergency engine shut off
- Instrumentation (I/O): fuel; oil pressure; water temp.; speedometer; tachometer; trim indicator; voltmeter; (OB): tachometer; speedometer; fuel; voltmeter; trim indicator
- Molded fuel tank, (32 gal.) in-floor
- Power trim & tilt (I/O)
- Power trim & tilt, VRO™ (OB)
- Steering wheel (padded)
- Stereo AM/FM cassette w/weatherband & 2/speakers
- Canvas top
- Carpeting
- Engine compartment insulation (I/O)
- Engine hatch, easy access, hinged
- Glove box
- Ice chest, integrated

- Seating: adjustable driver's seat; hinged bow seats; back-to-back seats (folds to sleeper); jump seats remove or make sundeck (I/O)
- Ski locker door; teak
- Storage: bow area; sidewall; floor (ski); concealed top (I/O)
- Winning Edge™ 3-Year Owner Protection*

Major Options

- Full canvas
- Depth Sounder
- Swim platform, teak insert
- Stereo upgrade
- SLX packages
- Portable head w/ privacy curtain (Convertible only)

For a complete list of standard and optional features ask your dealer for the 180 Horizon Feature Flyer

* Ask your Four Winns Dealer for full warranty details.



Integrated swim platform w/ladder extends Horizon utility.

Brougham Seating

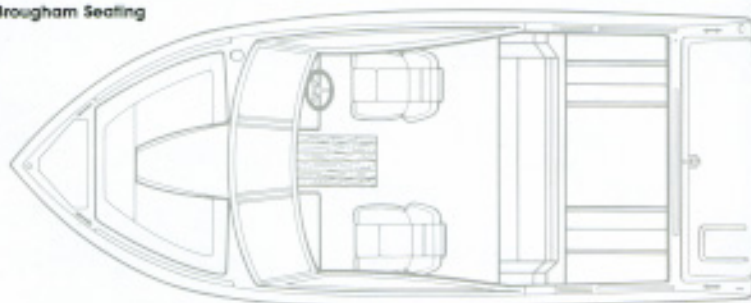

Standard Seating (Convertible)

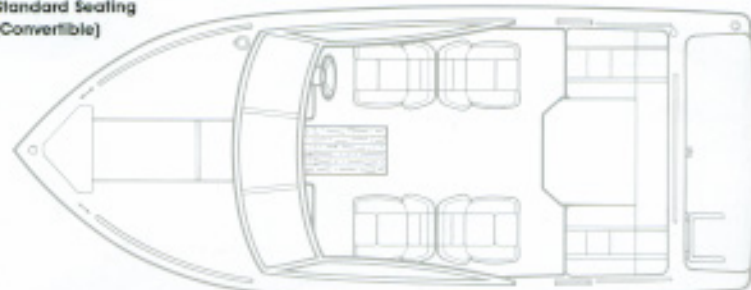

Specifications:	180-180 Convertible
LOA/Transom to Bow:	18'6"/17'1"
Beam:	7'3"
Boat Weight† [lbs.] w/175-HP I/O:	2420/2470
Boat Weight† [lbs.] w/120-HP OB:	1970/2020
Fuel (gal.):	32
Power (HP):	I/O 4.3L/175, 5.0L-HO/200; OB 120, 150 (Johnson® or Evinrude®)
Passengers/Capacity (lbs.):	I/O 8/1040 OB 8/1130
Keel to Windshield:	57"
Freeboard:	28"

† Boat weight based on design estimate



1. A Four Winns Sure Load™ color-matched trailer completes the 180 package.
2. 180 Horizon Convertible with hinged center entry
3. Full instrument panel features large, easy-reading gauges and reliable rocker

GREAT SHAPE IN SPORTBOATING



In-floor ski locker
w/teak lid.

"Got the bait?... Got the rods?...
Got the lunch?," barks the grand-
father.

The son and grandson respond
together in perfunctory stac-
cato... "Bait?..." "Check."
"Rods?..." "Check."
"Lunch?..." "Check."

The trio, so comforta-
ble and at ease in their
relationship, replay a
scene from Americana
as old as families and
boating.

More than 80% of all
owners of recreational
boats use their craft
for fishing some of
the time.



We're not talking here about fish-
ing for thrill and/or profit as in the
high-stakes, high-pressure, high-
psych world of tournament angling
but rather about the "joy of fishing"
as immortalized by Sir Isaak Walton
Thoreau, Hemingway and others...

As in still fishing contentedly ova
a deep hole with night crawler and
bobber...

Or trolling patiently through the
known habitat of a legendary lunke
whose local notoriety rivals the
Loch Ness monster...

Or "fishin the stumps" close to
shore using a "can't miss" fly,
artfully placed with a practiced flip
passed down through the
generations.

200 HORIZON



Most of the time, it's not the catch that's important... it's the sharing. The boat, the bait, the rods, the lunch... the lake itself, and even the day are all simply props in a cherished family portrait.

These are anglers who would say, mischievously, "apple pie is as American as fishing."

Everything good we said about the 180 Horizon™ on pages 12 & 13 we say "ditto-plus" for the 200 Horizon. We've engineered in more room, comfort, convenience and utility than in any comparably-sized Four Winns runabout yet. That's more good reason to compare the 200 Horizon and new 200 Horizon Convertible to competitive 19-, 20- and 21-foot models.



In terms of standard features... ergonomics... innovation... and contemporary styling... it's hard to imagine a more complete sportboat. With standard Winning Edge™ 3-Year Owner Protection it's hard to imagine a better value.

If competition wants to match our Horizons, they're going to have to expand theirs. 

Major Std Features

- Anchor locker, bow
- Bilge, auto pump
- Rails, stainless
- Closed bow with hinged center entry (Convertible only)
- Cleats (4)
- Gel coat, two tone
- Ski eye, stainless (i/o)
- Swim platform, fiberglass, integrated with ladder
- Trailer, single axle, color-coordinated

- Windshield, vinyl tempered, bent glass w/walk-through
- AM/FM antenna w/noise suppressor
- Aluminum fuel tank, (44 gal) in-floor
- Bilge blower (i/o)
- Bilge, gel coat
- Emergency engine shut off
- Instrumentation (i/o): fuel, oil pressure, water temp., speedometer, tachometer, trim indicator, voltmeter, (OB): tachometer, speedometer, fuel voltmeter, trim indicator
- Power trim & tilt (i/o)
- Power trim & tilt, VRO™ (OB)
- Steering wheel (padded)
- Stereo AM/FM cassette, w/weatherband & 2 speakers
- Canvas top
- Carpeting
- Engine compartment insulation (i/o)
- Engine hatch, easy access, hinged
- Glove box
- Ice chest, integrated

- Sunring, adjustable
- Driver's seat, hinged
- Bow seats, back-to-back seats (folds to sleeper), jump seats remove or make sundeck (i/o)
- Ski locker door, teak
- Storage: bow area, sidewall, floor (ski); concealed top (i/o)
- Winning Edge™ 3-Year Owner Protection*

Major Options

- Full canvas
- Depth Sounder
- Portable head w/ privacy curtain (Convertible only)
- Swim platform, teak insert
- Stereo upgrade
- SLX package

For a complete list of standard and optional features ask your dealer for the 200 Horizon Feature Flyer

* Ask your Four Winns Dealer for full warranty details.



Outboard models feature factory pre-rigged Johnson® or Evinrude® power to 200-HP.

Brougham Seating

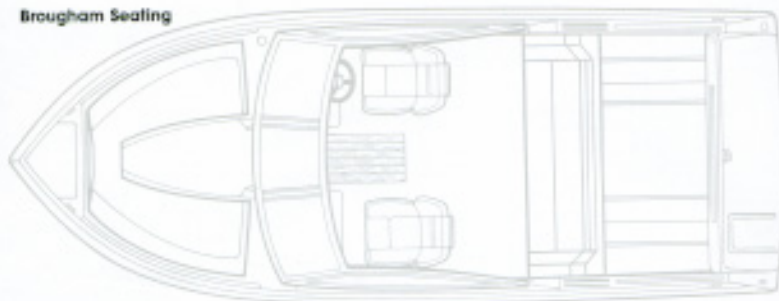

Standard Seating (Convertible)

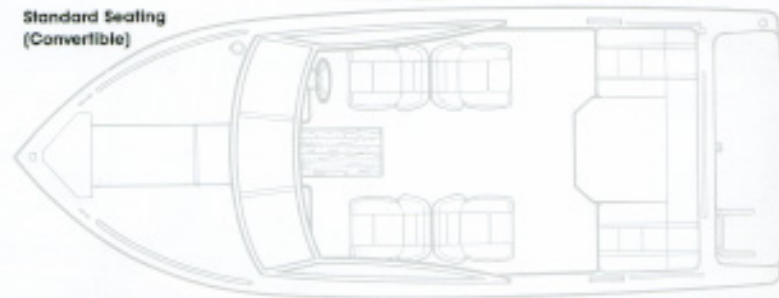

Specifications:	200-200 Convertible
LOA/Transom to Bow:	20'9"/19'4"
Beam:	7'8"
Boat Weight ¹ (lbs.) w/200-HP i/o:	2870/3020
Boat Weight ¹ (lbs.) w/175-HP OB:	2310/2460
Fuel (gal.):	44
Power (HP):	i/o 4.3L/175, 5.0L-HO/200, 5.8L/235, 5.7L/260 OB 120, 150, 175, 200 (Johnson® or Evinrude®)
Passengers/Capacity (lbs.):	i/o 10/1410 OB 10/1410
Keel to Windshield:	64"
Freeboard:	33"

¹Boat weight based on design estimate



1. The innovative 200 Convertible offers lockable concealed storage space.

2. Concealed anchor storage at the bow.

3. Gauges and switches are easy to find with hand or eye.

GREAT
SHAPE IN
SPORTBOATING

WINNgear™ is the name we've created to identify the bold, bright, stylish collection of shirts, sweaters, shorts, jackets, sweats and headwear available exclusively from Four Winns



and Four Winns Dealers. Easy-care cotton and cotton blends... unique "puffed" graphics, and subtle color combinations help these quality wearables stand out dockside or at the beach.

With XS to XXL sizes for women and men, plus children's sizes in several items, the opportunity is there to keep the whole family lookin' nautically good.

WINN·GEAR

Top of the Dock

Totally Nautical...Totally Unique...

Four Winns has also created a whole new way to participate in the boating lifestyle.

Top of the Dock® is America's boating lifestyle store... a totally nautical, totally unique Four Winns concept designed for the boating family... or for those who just like the boating look.

In conjunction with our dealers, we're opening Top of the Dock Mall Stores and Shoppes in major retail

210 HORIZON

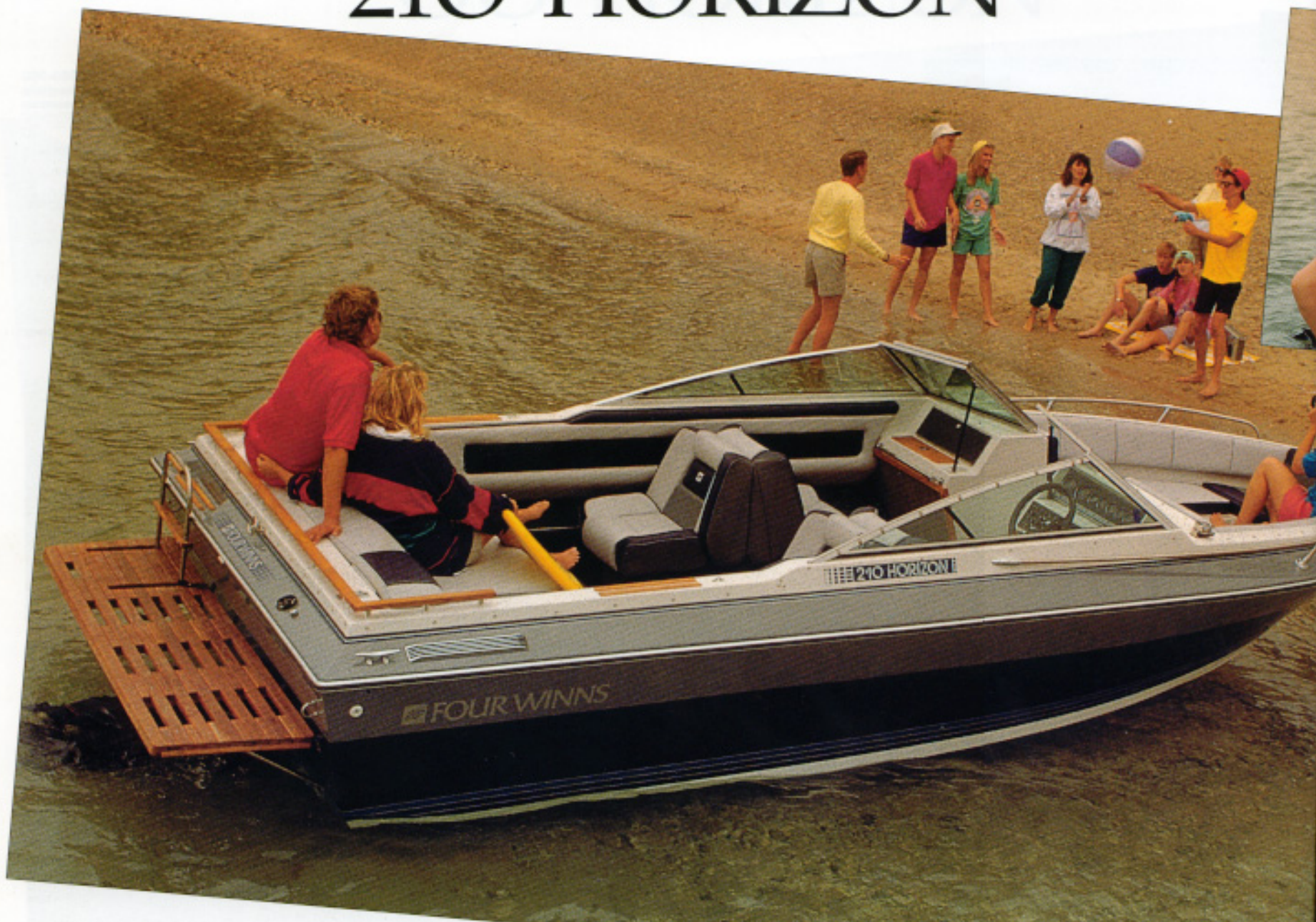

shopping centers and Four Winns Dealerships throughout the country featuring designer swim-wear and casual-wear...namebrand footwear...top brand waterskis, vests and ski accessories... nautical gifts...and, of course, Four Winns powerboats from 15' to 31'.

By July of 1989 we'll offer catalog sales of Top of the Dock® and WINN-gear® clothing and accessories.

Send us a postcard with your name and address and we'll mail you a catalog as soon as it's printed:

Top of the Dock/WINN-gear
925 Frisbie Street
Cadillac, MI 49601



Timeless in appearance, the luxurious 210 Horizon™ is as current as anything on the water. It's a big, beamy open bow runabout that provides a stable platform under a variety of water conditions. Like all Four Winns Classic designs, the 210 caters to the purist whose boating life-style is more accurately described by the graceful

silhouette of traditionally styled craft. Powerful OMC Cobra® and OMC King Cobra® stern drives to 340-HP. Optional Brougham seating, available on all Horizon models, includes adjustable bucket seats, a full width stern couch and a broad padded sundeck.



Digital depth sounder is standard.

Major Std Features

- Blige, auto pump
- Bow rails, stainless
- Cleats (4)
- Gel coat, two tone
- Ski eye, stainless
- Step pads, teak
- Swim platform, full teak, w/ladder
- Taffrails, teak
- Trailer, tandem axle color-coordinated
- Windshield, tinted/tempered, with walk-through
- AM/FM antenna w/noise suppressor
- Aluminum fuel tank, (44 gal.) in-floor
- Blige blower
- Blige, gel coat
- Depth sounder
- Emergency engine shut off
- Instrumentation: fuel; oil pressure; water temp.; speedometer; tachometer; voltmeter
- Power steering
- Power trim & tilt
- Steering wheel (padded)
- Stereo AM/FM cassette, w/weatherband, & 2/speakers
- Canvas top
- Carpeting
- Drink holders (cockpit)

- Engine compartment insulation
- Engine hatch, easy access, hinged
- Glove box
- Ice chest, integrated (48 quart)
- Passenger grab rail
- Seating: adjustable driver's seat; hinged bow seats; back-to-back seats (folds to sleeper); jump seats remove or make sundeck (I/O)
- Ski locker door, teak
- Storage: bow area; sidewall; floor (skt); concealed top
- Winning Edge™ 3-Year Owner Protection*

Major Options

- Full canvas
- Gel coat, three tone
- Fiberglass floor
- Swim platform, fiberglass
- Stereo upgrade
- SLX packages
- Trim tabs, hydraulic

For a complete list of standard and optional features ask your dealer for the 210 Horizon Feature Flyer

* Ask your Four Winns Dealer for full warranty details.

Specifications:

LOA:	21'
Beam:	8'
Boat Weight ¹ (lbs.) w/260-HP I/O:	3100
Fuel (gal.):	44
Power (HP):	I/O 5.0L/10/200, 5.8L/235, 5.7L/260, 460CI/340
Passengers/Capacity (lbs.):	10/1400
Keel to Windshield:	68"
Freeboard:	36"

¹Boat weight based on design estimate

Standard Seating

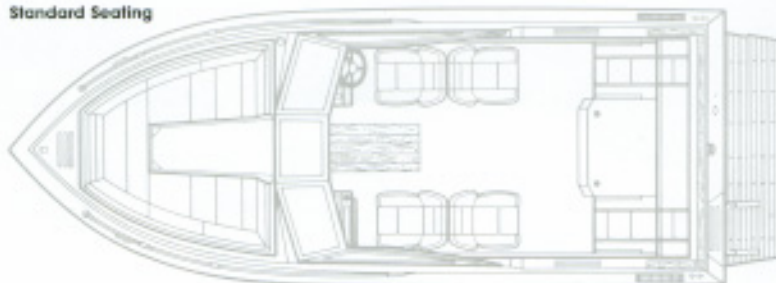

Brougham Seating

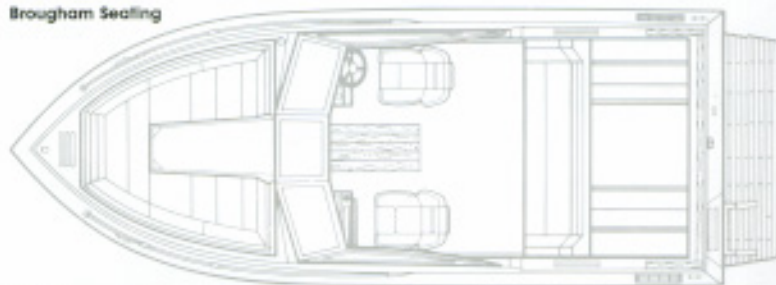

The classic look of teak... in the swim platform, taffrails and step pads.

1. Responsive, quick planing deep-vee hull powered with up to a 340-HP OMC King Cobra® stern drive.

2. Optional color-matched full canvas including side and aft curtains and bow cover.

3. Soft-feel sports vinyl seat full.



GREAT SHAPE IN DECK BOATING



In its simplest terms we define a boat as "vessel for traveling through water". If all we want to do is move between two places separated by water, that description will suffice.

But for the boating family, their craft is seldom used solely for transportation. Rather, the boat is often an entrée to a world inaccessible to the landbound.

Imagine a field trip on a wilderness stream whose levee and bottomlands have been preserved by the Wetlands Act, or by restriction of a local environmental agency. In this context, the boat is a



time machine... gliding silent and wakeless through the theme park we call Natural History.

Along every foot of the storied banks the natural order plays its course. Around every bend of the serpentine route another drama of life unfolds, seamier and more sensational than a soap opera... fish, fowl, amphibians, reptiles,

insects and vegetation participating in a food chain that brings a delicate balance to the teeming environment.

To be an educated observer of nature you need the right tools...

Written and pictured records of rare species of plant and animal life of the region—available from your State's Department of Natural Resources, or a local chapter of an environmental agency, or in your community library...

A powerful set of binoculars so you can observe without obstructing...

a camera, pad & pencil, and tape recorder to document and preserve your observations...

and, most importantly, a boat to gain access to this private world where humans are privileged visitors.

180 CANDIA

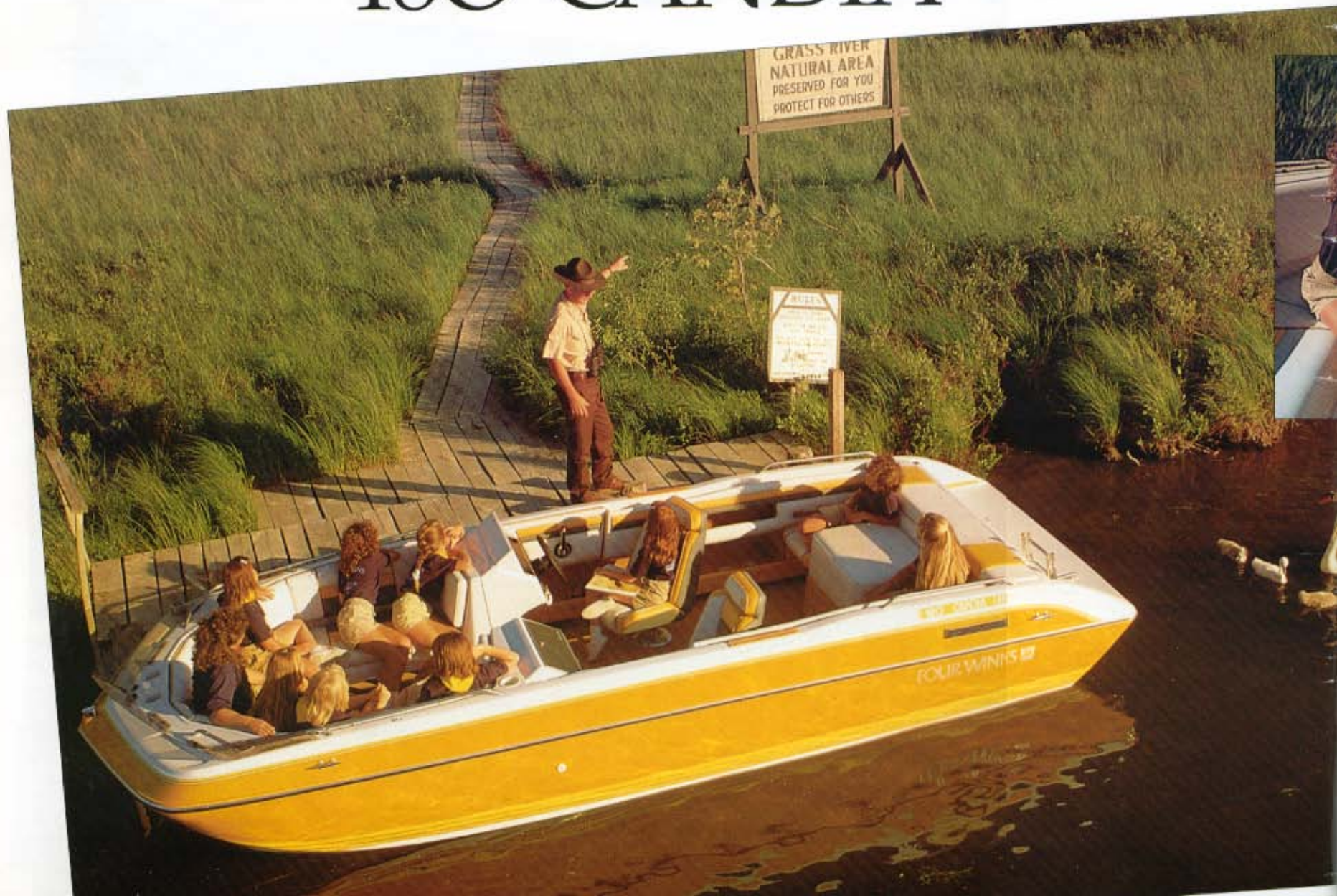

Please remember, obligation goes hand in hand with privilege. Leave the natural setting the same way you found it. An untrimmed prop can disrupt aquatic breeding beds. A single gum wrapper or styrofoam cup carelessly discarded can be more than a blight... it can be a threat to the very survival of a rare species.



The Four Winns 180 Candia™ is one of the reasons deck boating attracts such an enthusiastic band of loyalists.

Evinrude® outboard... plenty of punch pulling multiple skiers. Popular options for stern drive 180 Candia includes sporty Brougham seating and the value enhancing SLX package with tri-tone gel coat color scheme, stereo upgrade, depth sounder, bow fill-in cushions, chart light/lighter and more. And the entire stylish package comes cradled on it's own color-coordinated Four Winns Sure Load™ Trailer.

Consider the advantages. A step pad hull supports a broad, stable platform... an ideal layout for on-board entertaining. Power is supplied by OMC Cobra® stern drive to 200 HP, or by a 120-HP Johnson® or



Stainless ski eye is standard (stern drive).

Optional, removable table provides utility in the bow (included in SLX Package).



Standard Seating

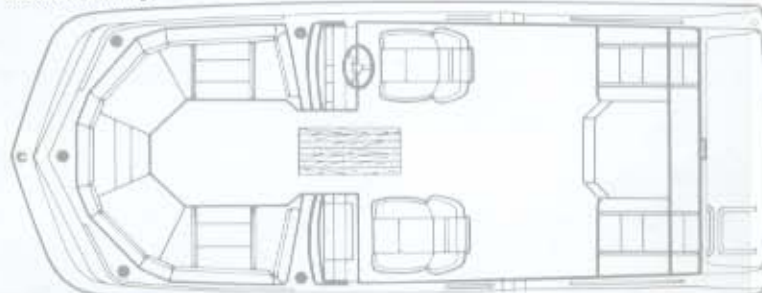

Brougham Seating

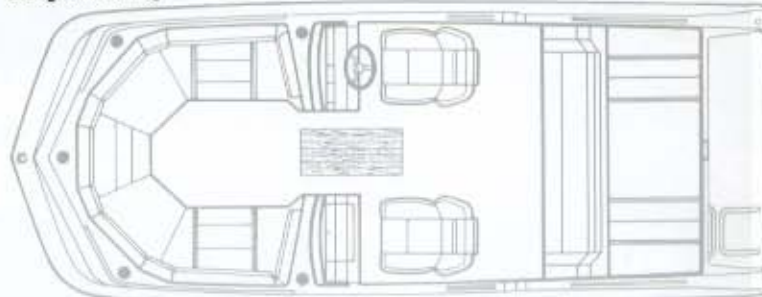

Major Std Features

- Bilge, auto pump
- Cleats (4)
- Gel coat, two tone
- Ski eye, stainless (I/O)
- Stainless rails
- Swim platform, fiberglass, integrated w/ladder
- Trailer, single axle, color-coordinated
- Venturi windshield
- AM/FM antenna w/noise suppressor
- Aluminum fuel tank, (27 gal.) in-floor
- Bilge blower (I/O)
- Bilge, gel coat
- Emergency engine shut off
- Instrumentation (I/O): fuel, oil pressure, water temp.; speedometer; tachometer; trim indicator; voltmeter. (OB): Speedometer; tachometer; fuel; voltmeter.
- Power steering (I/O)
- Power trim & tilt (I/O)
- Power trim & tilt, VRO™ (OB)
- Steering wheel (padded)

- Stereo AM/FM cassette w/weather-band & 4 speakers
- Canvas top
- Carpeting
- Courtesy lights
- Drink holders
- Engine hatch, insulated, hinged (I/O)
- Glove box
- Ice chest, integrated
- Port console
- Seating: adjustable driver's seat; bucket seat; hinged bow seats; jump seats remove or make sundeck (I/O)
- Ski locker door, teak
- Storage: bow area; sidewall; in-floor ski; concealed top (I/O)
- U-Shaped bow seating
- Winning Edge™ 3-Year Owner Protection*

Major Options

- Depth sounder
- Gel coat, three tone
- Swim platform, teak insert
- Stereo upgrade
- SLX package

For a complete list of standard and optional features ask your dealer for the 180 Candia Feature Flyer

* Ask your Four Winns Dealer for full warranty details.

Specifications:

LOA/Transom to Bow:	19' 8" / 18' 3"
Beam:	7' 8"
Boat Weight ¹ (lbs.) w/175-HP I/O:	2860
Boat Weight ¹ (lbs.) w/120-HP OB:	2440
Fuel (gal.):	27
Power (HP):	I/O 4.3L/175, 5.0L-HO/200 OB 120 (Johnson® or Evinrude®)
Passengers/Capacity (lbs.):	I/O 10/1411 OB 10/1411
Freeboard:	31"

¹Boat weight based on design estimate



2.



1. Capacity for up to 10... power up to 200-HP stern drive.
2. Outboard powered models feature driver and passenger swivel buckets, wrap-around bow seating. (Stern bench available Brougham and outboard only)
3. Recessed gauges and accessible



GREAT SHAPE IN DECK BOATING



Convenient ski storage in floor.

Walk into a trendy gift shop in Any Mall, U.S.A., and you'll probably find a brass plaque engraved with the following:

"A boat is a box floating on water into which you pour money until it sinks."

Any experienced boater could quickly counter such negativism with case history upon case history of memorable family boating fun that didn't destroy the family budget.

Dollar for dollar, no recreation provides a better return on investment than boating. For the price of a tank of gas and a packed lunch,



a family can spend a whole day together on the water swimming, skiing, fishing, or just rafting-off with friends on a peaceful sandbar.

The fact is, after an initial investment in specialized gear, life on the water can be downright frugal.

One adventurous water sport everybody in the family can participate in, and one that doesn't take a small fortune to get into, is snorkeling.

Essential equipment consists of a mask with attached breathing tube, flippers and flotation vest. You can outfit every member of your family with quality gear for about \$75 per person.

The only thing else you have to spend is your own energy as you and your family discover a fascinating, colorful and diversified world beneath the surface.

Like all specialized activities there are a few guidelines you need to establish so that snorkeling is safe, fun and enjoyable for all.

- Never snorkel alone no matter how expert you are as a swimmer.

200 CANDIA

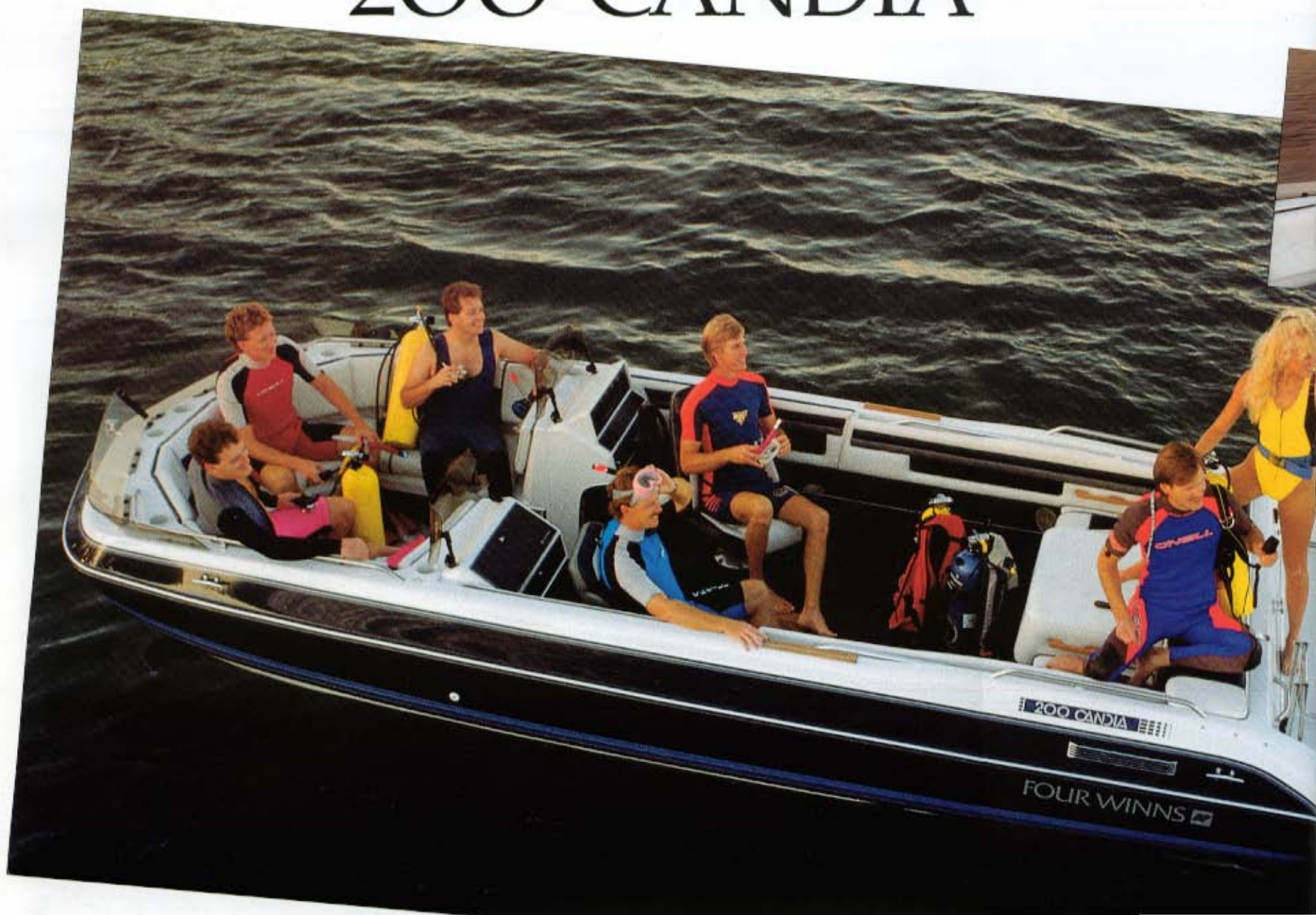

- Anchor your boat securely and use a flagged buoy to alert other boaters of your presence in the area.
- Research unfamiliar waters before you snorkel. A local divers club is a good source for information.
- Use a diver's watch to keep tabs on how long you've been in the water.
- Don't overextend yourself physically. Set time limits on your exploration.
- Never start your boat's engine until all swimmers are on board.



Spaciousness, comfort and utility share equal billing with style and performance in the versatile Four Winns 200 Candia™ deck boat. A passenger layout that can accommodate up to 13 makes the 200 Candia one of America's premier party boats. The conversation pit in the bow doubles as a generous sundeck with optional fill-in cushions. AM/FM 4-speaker stereo cassette with

weatherband, stainless ski eye, in-floor ski locker, passenger console with integrated cooler, and color-matched trailer are all standard. Stern drive power ranges from 175 to 260 HP. And isn't it comforting to know that Winning Edge™ 3-Year Owner Protection is included in the affordable price? 



Major Std Features

- Bilge, auto pump
- Cleats (4)
- Gel coat, two tone
- Ski eye, stainless
- Stainless rails
- Swim platform, fiberglass, integrated w/ladder
- Trailer, tandem axle, color-coordinated
- Venturi windshield
- AM/FM antenna w/noise suppressor
- Aluminum fuel tank, (27 gal.) in-floor
- Bilge blower
- Bilge, gel coat
- Emergency engine shut off
- Instrumentation: fuel; oil pressure; water temp.; speedometer; tachometer; trim indicator; voltmeter.
- Power steering
- Power trim & tilt
- Steering wheel (padded)
- Stereo AM/FM cassette w/weatherband & 4 speakers
- Canvas top
- Carpeting
- Courtesy lights

- Drink holders
- Glove box
- Ice chest, integrated
- Engine hatch, hinged, insulated
- Port console
- Seating: adjustable driver's seat, bucket seat; hinged bow seats; jump seats remove or make sundeck
- Ski locker door, teak
- Storage: bow area; sidewall; in-floor ski; concealed top
- U-Shaped bow seating
- Winning Edge™ 3-Year Owner Protection*

Major Options

- Depth sounder
- Gel coat, three tone
- Swim platform, teak insert
- Stereo upgrade
- SLX package

For a complete list of standard and optional features ask your dealer for the 200 Candia Feature Flyer

* Ask your Four Winns Dealer for full warranty details.



Venturi windshield helps keep the bowriders dry and comfortable.

Standard Seating

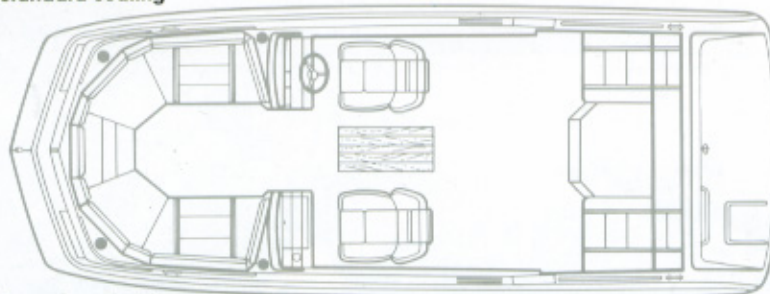

Brougham Seating

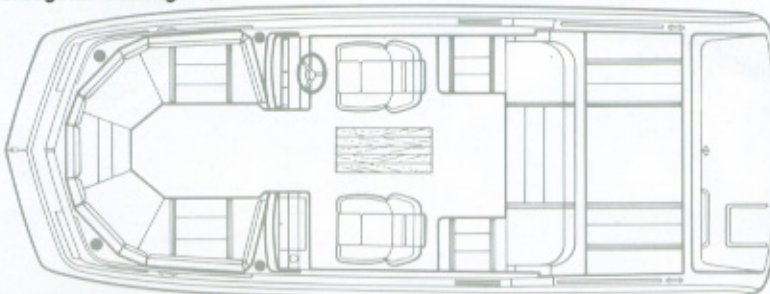

Specifications:

LOA/Transom to Bow:	21'7" / 20'
Beam:	8'
Boat Weight ¹ (lbs.) w/200-HP I/O :	3240
Fuel (gal.):	27
Power (HP):	I/O 4.3L/175, 5.0L-HO/200, 5.8L/235, 5.7L/260
Passengers/Capacity (lbs.):	13/1805
Freeboard:	30"

¹Boat weight based on design estimate



2.



1. OMC Cobra® stern drive power available to 260-HP.
2. Canvas top is standard, and color-matched to the hull with SLX option.
3. Soft-feel steering wheel centers full instrumentation.



AFFORDABLE FAMILY CRUISING

Early on in our boating experience most of us develop a condition known as "Boater's Pride". It manifests itself in a ritualistic devotion Saturday mornings in season. Attendance is mandatory for *all* family members.

One parent – usually the father – delivers a stiff sermon on the virtues of boat cleanliness, while the other administers to the flock, passing out sponges, brushes, chamois, pails, towels, degreasers, spritz bottles, rubbing compound, and paste wax.

Usually, once the work begins the mood lightens up and restoring the craft to its showroom lustre becomes a labor of love for all.



Four Winns Boat Care Kit, available at participating dealers.

With enough willing hands, and a systematic approach, a twenty footer can be thoroughly cleaned bow to stern, bilge to gunwhales in under 30 minutes.

That's a small investment in time compared to the return on investment you'll realize when selling a well maintained boat.

In addition to routine cleaning, basic repair work may be necessary from time to time to counter the effects of weathering and minor dock damage. Dennis Harner, Warranty Manager at Four Winns, offers this advice for general boat upkeep:

Fiberglass chafing or "dock rash".

Apply a good rubbing compound with mild abrasive to the area and buff thoroughly using your power drill with buffing attachment.

Minor gel coat patching. Clean and lightly sand area to be patched (600 grit paper). Prepare patch per directions on patch kit – usually by thoroughly mixing one or two drops

205 SUNDOWNER

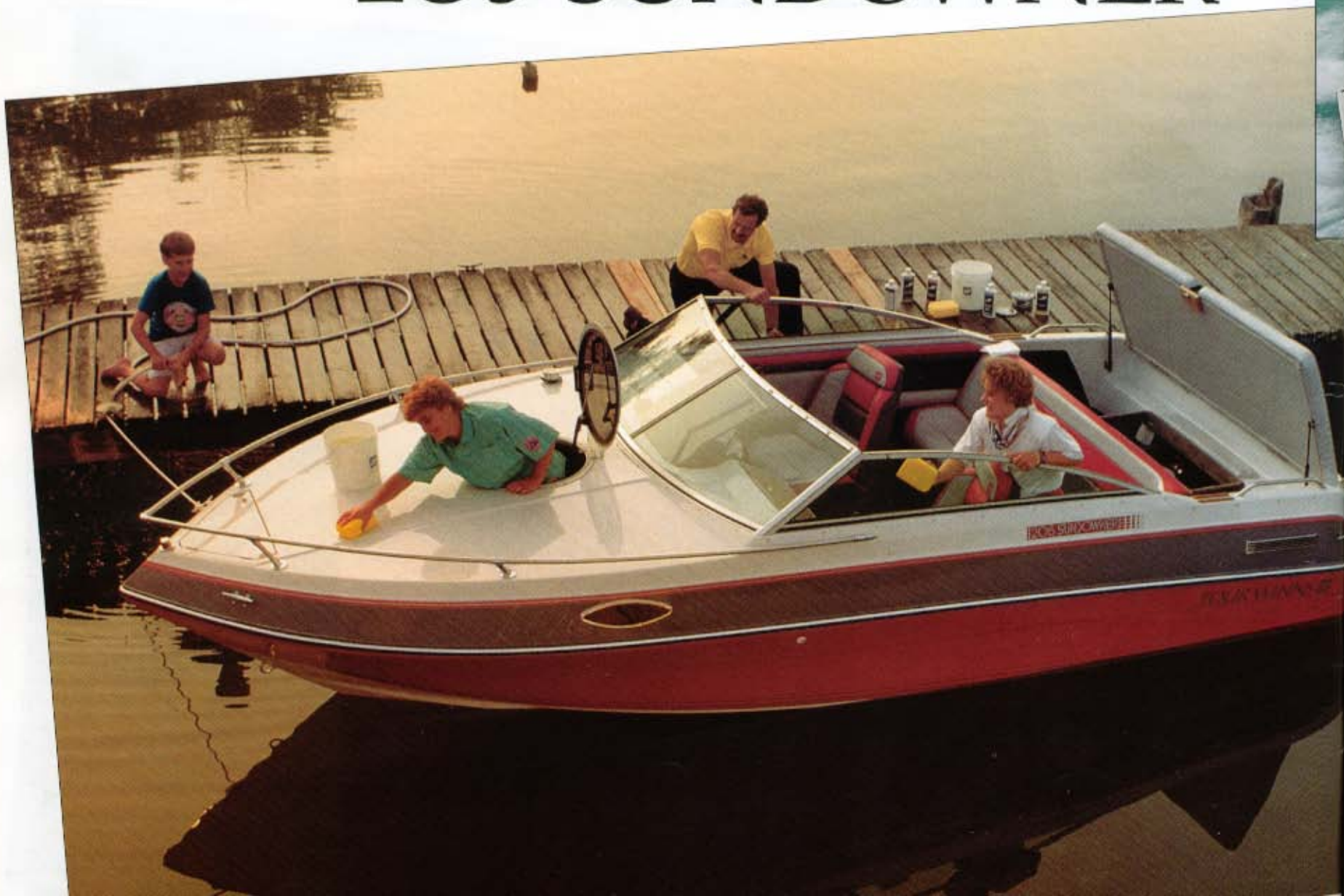

of catalyst with the color. Work patch into the fiberglass. Let it set up. Sand smooth. Buff until patch and surrounding color and gloss are uniform.

Vinyl and canvas stains. One or two caps of a good liquid soap in a pail of warm water. Apply with a soft bristle brush and lots of elbow grease. Rinse and repeat as necessary.

Preventative maintenance to counter weathering. All gel coat will fade when constantly exposed to the sun. To minimize fading frequently apply a good quality paste wax and buff to a high gloss. Use a mooring cover whenever boat is not in use.



Four Winns has a place for those ready to move out of the run-about class... the 205 Sundowner™, a cut above in style, performance, and in the welcome convenience of a cozy cuddy cabin with vee-berths designed for six-footers. The desirable amenities are standard... stereo system with noise suppressor antenna, depth sounder, bow anchor locker, full gauge instrumentation, ski tow, passenger console with ice chest,

color-matched trailer. Styling is pure Four Winns contemporary... the appealing sheer line... distinctive round deck hatch... unique integrated swim platform with folding ladder are all Four Winns design signatures that help set the 205 Sundowner apart from the ordinary. Nothing ordinary about the performance of OMC Cobra® stern drive or Johnson® or Evinrude® outboard power either.

Major Std Features

- Aluminum fuel tank, (44 gal.) in-floor
- Auto bilge pump
- Bilge, gel coat
- Bilge blower (I/O)
- Deck hatch, round
- Depth sounder
- Emergency engine shut off
- Instrumentation (I/O): fuel; oil pressure; water temp.; speedometer; tachometer; trim indicator; voltmeter, (OB); tachometer; speedometer; fuel; voltmeter; trim indicator
- Power steering
- Power trim & tilt (I/O)
- Power trim & tilt, VRO™ (OB)
- Steering wheel (padded)
- Stereo AM/FM cassette, w/weatherband & 4 speakers
- Cabin door w/hasp, plexiglass
- Carpeting
- Canvas top
- Drink holders (cockpit)
- Engine compartment insulation (I/O)
- Engine hatch, easy access, hinged
- Anchor locker, bow
- Rails, stainless
- Cleats (4)
- Gel coat, two tone
- Port lights (2)
- Ski eye, stainless (I/O)
- Swim platform, fiberglass, integrated with ladder
- Trailer, tandem axle, color-coordinated
- Windshield, tinted/tempered, bent glass with vented wings
- AM/FM antenna w/noise suppressor

- Glove box
- Ice chest, integrated
- Seating: adjustable driver's seat; back-to-back seat (folds to sleeper); jump seats remove or make sundeck (I/O); vee-berth cushions
- Sleeping for 2: vee-berth
- Storage: bow area; sidewall; under berth; concealed top (I/O)
- Winning Edge™ 3-Year Owner Protection*

Major Options

- Full canvas
- Gel coat, three tone
- Swim platform, teak insert
- Stereo upgrade
- SLX package

For a complete list of standard and optional features ask your dealer for the 205 Sundowner Feature Flyer

* Ask your Four Winns Dealer for full warranty details.



Stern drive power range: 175 HP to 260 HP.

Standard Seating

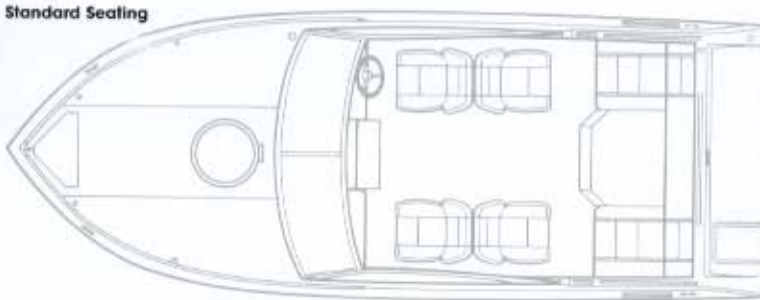

Brougham Seating

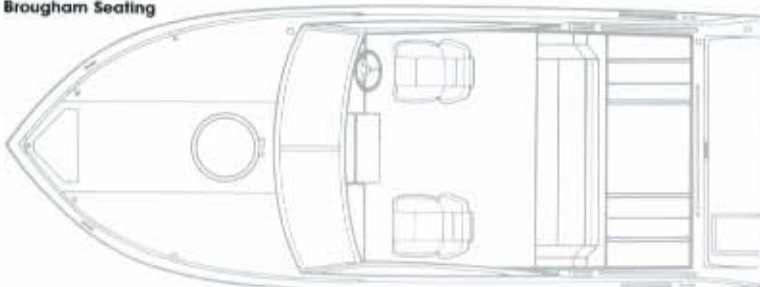

Specifications:

LOA/Transom to Bow:	20'9" / 19'4"
Beam:	7'8"
Boat Weight ¹ (lbs.) w/200-HP I/O:	3040
Boat Weight ¹ (lbs.) w/175-HP OB:	2650
Fuel (gal.):	44
Power (HP):	I/O 4.3L/175, 5.0L-HO/200, 5.8U/235, 5.7U/260 OB 120, 150, 175 (Johnson® or Evinrude®)
Passengers/Capacity (lbs.):	I/O 10/1410 OB 10/1410
Keel to Windshield:	67"
Freeboard:	38"

¹Boat weight based on design estimate

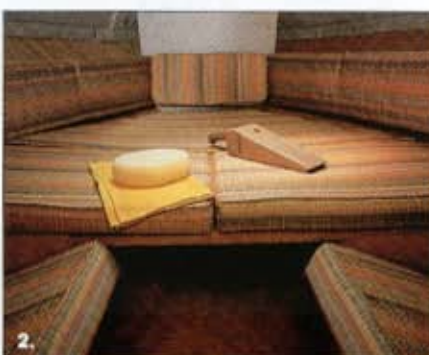

2.



1. Style, size and a standard trailer make the 205 Four Winns most popular cuddy. (Shown here in outboard configuration).
2. Ample vee-berth sleeps two.
3. Complete instrumentation at the helm.



AFFORDABLE FAMILY CRUISING

In terms of investment, the family boat and the family car may be quite similar. However, important distinctions surface in the way we use these different transportation modes.

For example, except for special instances, one or two family members do the car driving.

The family boat, on the other hand, is an integral component of an active lifestyle that can include waterskiing, fishing, sightseeing, entertaining friends and other pursuits. In the course of a day on the water, it's not unusual for several family members, and perhaps even friends and neighbors

to take a turn at the helm.

This is one of the great attractions of boating... it's an activity that nearly all teens and adults can enjoy and directly participate in.

Since

your boat does represent a considerable investment... and since you are ultimately responsible for the safety and well-being of your passengers and other boaters around you, it is reasonable and sensible to insist on a certain level of operating competence before handing over the keys.



Family members can quickly become proficient at the helm with practice at quiet times on your lake or waterway, with an experienced operator on board.

If you are uncertain about the qualifications of friends or neighbors who want to pilot your boat, ask questions. Don't give up the helm to anyone until you are confident of their ability.

Standard stereo
AM/FM cassette w/
weatherband.

215/225 SUNDOWNER



SUNDOWNER

For those maneuvers that require more skill – docking, launching from, or driving onto a trailer, navigating in a narrow channel or in heavy traffic – be sure an experienced boater is at the helm.

One excellent way to assure that at least the members of your immediate family become qualified and responsible boaters is to enroll them in the 13-step *Boating Skills & Seamanship Course* conducted several times a year in your area by the Coast Guard Auxilliary or Power Squadron. It's a proven program that can, for a nominal fee, benefit new and seasoned boaters alike. For information about the location and dates of the course in your area call 1-800 336 BOAT.

The classic 215 and 225 Sundowner™ models are traditionally styled powerboats large enough to handle coastal waterways, yet not over-sized for inland lakes. They're designed for boaters who appreciate the warmth and luxury of teak trim, the sophistication of a wave flattening deep-vee hull, and, of course, the convenience of a spacious cabin with generous vee-berth sleeping, and, in the 225, an enclosed portable head. Spirited stern drive power up to a 260-HP in the



The utility of a handsome full teak swim platform is a trademark of both the 215 (shown) and the 225 Sundowner

215 and 340-HP in the 225 provide ample muscle for skiing, fishing or other family boating activities. Like all Four Winns models, the 215 and 225 Sundowner provides the big edge over other makes... the Winning Edge™ 3-Year Owner Protection*... boating's strongest coverage.

Major Std Features

- Anchor locker, bow
- Bow rails, stainless
- Cleats (4)
- Deck hatch
- Gel coat, two tone
- Non-skid walk around deck (225)
- Port lights
- Ski eye, stainless
- Step pads, teak
- Swim platform, full teak w/ladder
- Trailer, tandem axle color-coordinated (215)
- Windshield, tinted/tempered, with vented wings

- AM/FM antenna w/noise suppressor
 - Aluminum fuel tank
 - Auto bilge pump
 - Bilge blower
 - Bilge, gel coat
 - Depth sounder
 - Emergency engine shut off
 - Instrumentation: fuel, oil pressure, water temp, gauges, speedometer, tachometer; trim indicator; voltmeter
 - Power steering
 - Power trim & tilt
 - Steering wheel (padded)
 - Stereo AM/FM cassette, w/weather-band & 4 speakers
 - Cabin door w/hasp, teak
 - Canvas top
 - Engine compartment insulation
 - Engine hatch, easy access, hinged
 - Head, portable, enclosed (225)
 - Ice chest, insulated
 - Seating: adjustable driver's seat; back-to-back seat (folds to sleeper); removable jump seats; vee-berth cushions
- Major Options**
- Fiberglass floor
 - Full canvas
 - Gel coat, three tone
 - Swim platform, fiberglass
 - Stereo upgrade
 - SLX packages
 - Trim tabs, hydraulic
- For a complete list of standard and optional features ask your dealer for the 215 or 225 Sundowner Feature Flyer
- * Ask your Four Winns Dealer for full warranty details.



Sundowner provides a rugged design for all weather cruising.

Standard Seating (215)

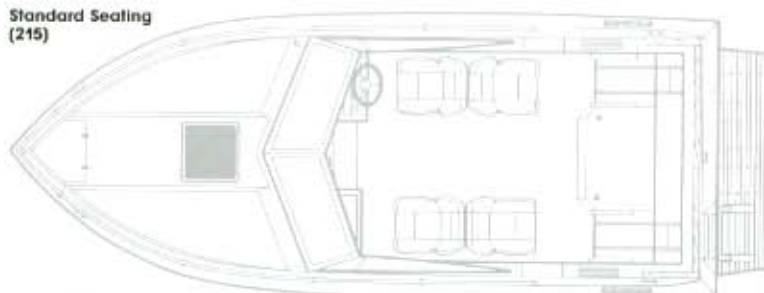

Cabin Interior (215)

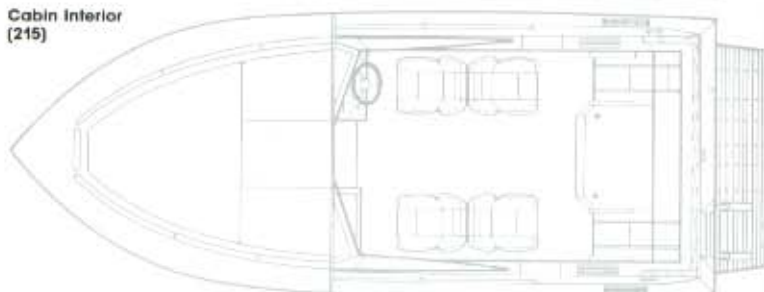

Specifications:	215	225
LOA/Transom to Bow:	21'	22'5"
Beam:	8'	8'
Boat Weight* (lbs.): w/260-HP engine	3290	3470
Fuel (gal.):	60	70
Power (HP):	1/0 5.0L HO/200, 5.8L/235, 5.7L/260	5.8L/235, 5.7L/260, 460CI-340
Passengers/Capacity (lbs.):	10/1400	10/1400
Keel to Windshield:	74"	83"
Freeboard:	40"	45"

* Boat weight based on design estimate.

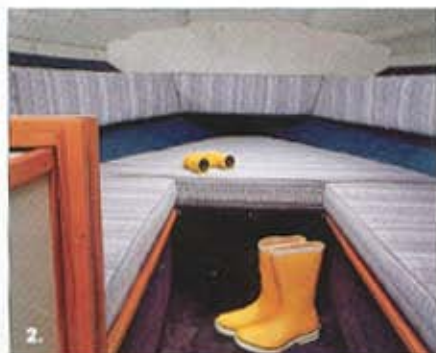

225 SUNDOWNER

1. Deep-vee hull and power to 340-HP make the 225 an excellent big water boat.
2. The spacious 215 cuddy cabin provides vee-berth and an enclosed head.
3. Helm station of the 215 Sundowner pays attention to ergonomics.

AFFORDABLE FAMILY CRUISING



Spend a little time at a busy marina and you'll come away with some very positive attitudes about the class of people who participate in the boating lifestyle.

In fact "class" fairly well describes the collective character of boaters. In the main, they're friendly, helpful, proud, fun-loving and generous to a fault. It shows in small ways that constantly surface in the behavior of boaters.

...in the faithful exchange of a wave and nod that passes between helmsman of inbound and outbound boats...

...in the readiness to come to the aid of a disabled boater...

...in the prideful, carefully coiled excess of mooring lines displayed on a dock...



...in the willingness to grab a line or supply a helpful nudge by those on the dock as a boat maneuvers into or out of a slip...

...in the hospitality extended by one boater in letting another "raft off" in a crowded marina.

It is, perhaps, the open friendly personality of boaters in general that accounts for a phenomenon that takes place on summer weekends in waterfront communities all over America. In some places they may be called the "Festival of Lakes", or "Venetian Night", or "Harbor Lights Festival"... the name is no matter... the objective is universal... to celebrate life and the best of times.

255 SUNDOWNER



Typically, these 2 or 3 day celebrations will include a roster of events and activities designed to draw visitors from hundreds of miles away... arts & crafts shows... carnival rides... ice cream socials... entertainment... fun runs... king and queen competitions and more. Always, the climax and focal point of the festivities is a gala parade of brightly lit and decorated boats visiting the harbor.

It's an idyllic way to enjoy warm weather and good friends, and a dramatic illustration of why boating is the lifestyle of choice for millions of families.

Our popular cuddy series includes a spectacular new expression of affordable family cruising... the stylish top of the line 255 Sundowner. It's a beamy, yet trailerable deep-vee design is equipped for big water family cruising. Standard full fiberglass liner, integrated swim platform with fiberglass transom entryway and two round deck hatches set the 255 apart from the classic design 235 Sundowner. Both

models are ideal for overnight port hopping with 100 gallon fuel capacity, enclosed head, galley with sink and ice box, and convertible dinette/vee-berths. A 340-HP OMC King Cobra® stern drive is available for both. The 255 Sundowner, may also, be ordered with twin 200-HP stern drives, trim tabs and counter-rotating props. 



Soft-feel sport wheel centers the stylish 255 Sundowner dash.

255 Sundowner Major Std Features

- Anchor locker, bow
- Rails, stainless
- Cleats (6), stainless
- Deck hatch (2 round)
- Gel coat, two tone
- Nonskid walk around deck
- Part lights (2)
- Prop(s), stainless
- Ski eye, stainless
- Swim platform, with ladder

- Fiberglass transom door, walk-thru
- Transom light
- Windshield, curved glass, tinted/tempered
- AM/FM antenna w/noise suppressor
- Aluminum fuel tank, (100 gal.) in-floor
- Auto bilge pump

- Bilge blower
 - Bilge, gel coat
 - Counter rotating props (twin only)
 - Depth sounder
 - Emergency engine shut off
 - Engine synchronizer (twins)
 - Hour meter
 - Instrumentation: fuel, oil pressure; water temp.; speedometer; tachometer; trim indicator; voltmeter.
 - Power steering
 - Power trim & lift
 - Steering wheel (padded)
 - Stereo AM/FM cassette, 60W equalizer; seek-scan w/ weatherband, 4 coaxial speakers & LED clock
 - Cabin door w/hasp
 - Canvas top
 - Carpeting
 - Engine compartment insulation
 - Engine hatch, easy access
 - Galley w/ice box, sink
 - Head, portable, enclosed
- Major Options**
- Full canvas
 - Gel coat, three tone
 - Swim platform, teak insert
 - SLX packages
 - Trim tabs
- For a complete list of standard and optional features ask your dealer for the 255 & 235 Sundowner Feature Flyers
- * Ask your Four Winns Dealer for full warranty details.



Available dockside power plugs you into the live-aboard lifestyle on 255 (shown) and 235 Sundowner.

Standard Seating (255)

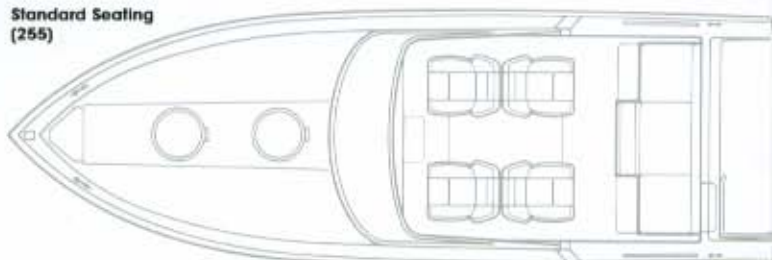

Cabin Interior (255)

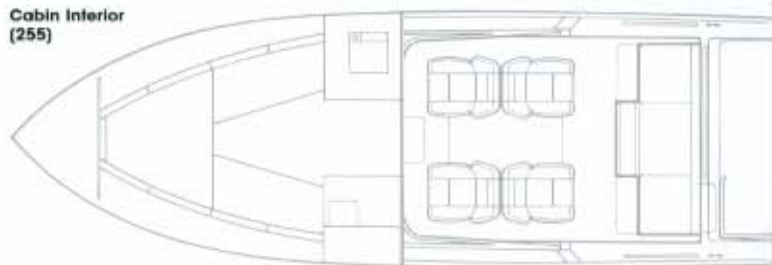

Specifications:	255	235
LOA/Transom to Bow:	26'2"/24'5"	23'8"
Beam:	8'6"	8'6"
Boat Weight ¹ (lbs.): w/260-HP engine	5000	4540
Fuel (gal.):	100	100
Water (gal.):	20	15
Power (HP) Single:	5.8L/235, 5.7L/260, 460CI/340	4.3L/175
Twin:	5.0L-HO/200	4.3L/175
Passengers/Capacity (lbs.):	10/1400 I/O	10/1410
Keel to Windshield:	89"	79"
Freeboard:	45"	39"

¹Boat weight based on design estimate



1. Classic design 235 Sundowner shares 8 1/2" beam with new contemporary design 255. Color-matched full canvas and tri-tone gel coat included with SLX-3 option on Sundowner models.
2. Smart graphics and distinctive round hatches accent the 255.
3. Below deck: a galley with sink, enclosed head, generous vee-berth/dinette. (255 shown).

AFFORDABLE FAMILY CRUISING

There's a part of earth that relatively few of us have ever visited... the silent, surreal, ever-twilight sub-surface world of our lakes, streams and oceans.

Many boating families spend much of their spare time exploring this universe unto itself while participating in one of America's fastest growing leisure activities... recreational diving.



Diving for fun comes in two levels of sophistication... breath-hold or scuba.

Breath-hold diving or snorkeling (see article, p. 20) is relatively inexpensive... young and old can partake... and you travel light.

The scuba diver's equipment bag, on the other hand, is heavy. Face mask with snorkel, air tank(s), air regulator, flotation vest, weight belt, pressure

gauge, diver's watch, swim fins and wet suit are just the basics. Start up costs, not including training, are about \$1500 per diver. Add underwater cameras and lights, spearfishing gear, voice communication systems, personal propulsion devices and other specialized equipment and the price can quickly go to the high four figures.

Scuba diving does take a great investment of money *and* time... requires specialized training... and participants must be generally healthy and fit. But for many, the payback in terms of adventure, challenge, education and camaraderie is well worth it.

245 VISTA



Most advocates of the sport belong to a larger community of divers. Any waterfront community of size probably has a local divers club. They're the source of best underwater attractions for visiting divers. Finding a local group may take some detective work. Start with the local yellow pages to see if there's a dive shop. Ask the harbor master or marina manager. Check with the Sheriff's Department.

To research potential diving sites before leaving your home port contact PADI (Professional Association of Diving Instructors), 1243 E. Warner Ave., Santa Anna, CA 92705. (714) 540-7234

The venerable 245 Vista continues as one of Four Winns most impressive designs. It's a mid-size cruiser with the classic lines and teak appointments that appeal to traditional boaters. A wide entryway leads to a full featured cabin with complete galley, generous storage and work surface. A hanging closet and enclosed head with shower and sink are starboard.

Forward dinette converts to comfort-



Cockpit includes driver's bucket seat, an L-shaped passenger lounge and optional stern couch.

able vee-berth sleeper. Two more can occupy the full width aft cabin with screened window and privacy curtain. Under the glass cockpit liner is your choice of single stern drive to 340 hors power or twin 175-HP stern drives. Counter-rotating props are included with twins.

Major Std Features

- Anchor locker, bow
- Rails, stainless
- Cleats (6) stainless
- Deck hatch
- Gel coat, three tone
- Nonskid walk around deck
- Port lights (4)
- Swim platform, full teak, w/ladder
- Transom light
- Walk-through transom door

- Windshield, tinted/tempered, with vented wings
- AM/FM antenna w/noise suppressor
- Aluminum fuel tank (72 gal.) in-floor
- Auto bilge pump
- Bilge blower
- Bilge, gel coat
- Counter rotating props (twins only)
- Depth sounder
- Emergency engine shut off
- Engine Synchronize (twins)

- Hour meter
- Instrumentation: fuel; oil pressure; water temp.; speedometer; tachometer; trim indicator; voltmeter.
- Power steering
- Power trim & tilt
- Steering wheel (padded)
- Stereo/AM/FM cassette 60W equalizer seek-scan w/weatherband & 4 coaxial speakers, LED clock
- Trim tabs, hydraulic
- Aft cabin
- Cabin door teak, w/lock
- Canvas top & cockpit cover, color-coordinated
- Carpeting, cabin
- Chrome vents
- Dinette table
- Fiberglass liner (self-bailing), cockpit
- Galley: alcohol stove, ice box, sink, storage
- Head, portable, enclosed
- Seating: bucket seat (adjustable driver's seat); L-shaped passenger seat

- Shower (pressurized)
- Sleeping for 4: aft cabin; vee-berth
- Storage: bow area; sidewall; under berth; floor (under steps)
- Vanity/sink, enclosed
- Water inlet (dockside)
- Water storage (15 gal.)
- Windows: aft cabin w/curtain & screen; side w/screens
- Winning Edge™ 3-Year Owner Protection*

Major Options

- Convenience group
- Full canvas
- Refrigerator
- Rotating L-shaped passenger seat stand

For a complete list of standard and optional features ask your dealer for the 245 Vista Feature Flyer

* Ask your Four Winns Dealer for full warranty details



The 245 Vista cruises the big water with up to a single 340-HP or twin 175-HP stern drives.

Standard Seating

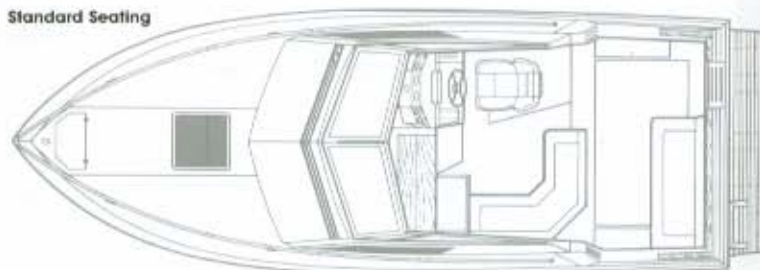

Cabin Interior



Specifications:

LOA:	23'8"
Beam:	8'6"
Boat Weight* (lbs.) w/260-HP engine:	5470
Boat Weight* (lbs.) w/twin 175-HP engine:	6170
Fuel (gal.):	72
Water (gal.):	15
Power (HP):	Single 5.7L/260, 460CI/340 Twin 4.3L/175
Passengers/Capacity (lbs.):	10/1410
Keel to Windshield:	96"
Freeboard:	32"
Bridge Clearance:	6'8"
Draft:	31"

* Boat weight based on design estimate



1. Intelligent galley design includes stove, ice box, sink and plenty of storage.
2. Aft cabin berth has side window with curtain and screen.
3. Wrap around full instrumentation.



A WHOLE NEW VISTA IN TRAILERABLE CRUISING



Optional cockpit washdown system with showerhead, mounts in the transom.

"What a wonderful party. Everything's so near your slip... club house, pool, sauna, tennis courts!"

That's social banter frequently overheard when friends gather at one of the growing number of "dockominiums" becoming popular along our waterways.

Securing a private slip at a marina development can take one of two courses... either you lease or rent the space, or you buy it.

With nominal down-payment, and a



variety of longterm financing plans available, you can purchase a boat slip as easily as a vacation home...and attendant tax write-offs are there for those who qualify. Usually, a monthly charge is assessed members to cover the cost of facilities maintenance and owner services.

Amenities, in addition to those above, may include private parking, lockable storage, dockside power/water/phone hookups, service bays,

winterizing, ship's store, gas dock, head pumpout and more... everything desirable for a hassle-free boating lifestyle. Some marina associations will even stock the galley and top off fuel and water tanks for members who call ahead.

Summer entertaining is no longer limited to the backyard barbeque. For many today, partying means gathering at a private slip and sharing the best of times with boating friends.

255 VISTA

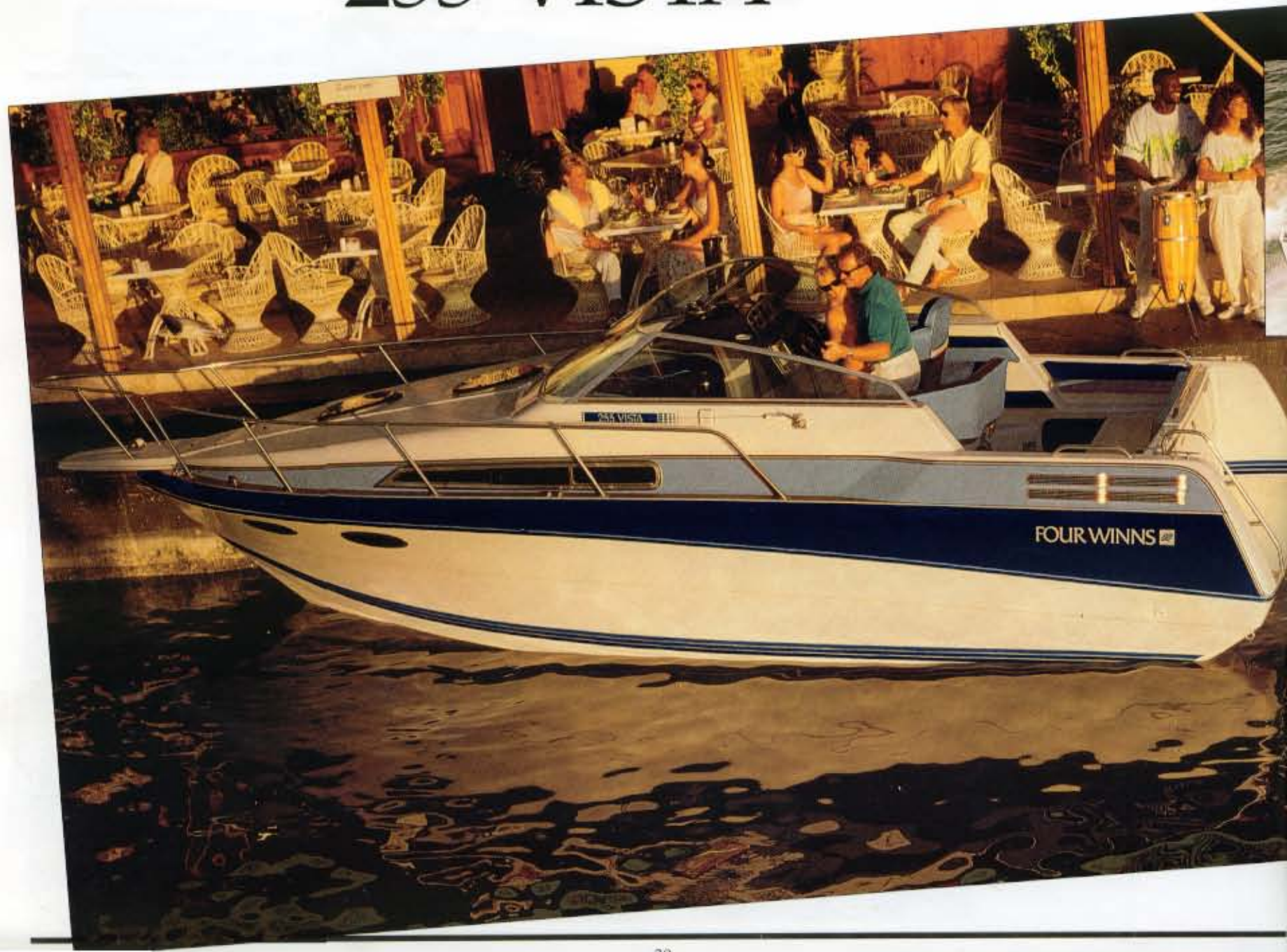

Some boaters prefer socializing at dockside; others while cruising on a calm, crimson lake at sunset... or under an umbrella of stars. The point is, socializing with family and friends at or on a boat affords a welcome break from the day's routine and offers an unparalleled opportunity to share the special bond that makes boating one of life's great celebrations.

Our new 255 Vista combines the best of popular wide-body cruisers with the convenience of a trailerable 8-foot 6-inch beam. With split galley, enclosed head with shower, vee-berth and aftcabin sleeping, the 255 is a very accommodating live-aboard.



Patented "bell-hatch" cabin entry slides on a single track.

With distinctive round hatches, full fiberglass cockpit liner, and L-shaped passenger lounge that pivots fore or aft on an optional rotating base, an innovative single-track "bell-hatch" cabin entryway and a large stylish integrate swim platform with fiberglass transom door, the 255 is also a thoroughly contemporary innovative alternative for today's cruising lifestyle.

Major Std Features

- Anchor locker, bow
- Rails, stainless
- Cleats (6), stainless
- Deck hatch (2), round
- Gel coat, three tone
- Nonskid walk around deck
- Port lights (4)
- Swim platform, with ladder
- Transom light

- Walk-through transom door with storage
- Windshield, tinted/tempered, with curved glass
- AM/FM antenna w/noise suppressor
- Aluminum fuel tank, (70 gal.) in-floor
- Auto bilge pump
- Bilge blower
- Bilge, gel coat
- Counter rotating out drives (twins only)
- Depth sounder

- Emergency engine shut off
- Engine hour meter
- Instrumentation: fuel; oil pressure; water temp.; speedometer; tachometer; trim indicator; voltmeter.
- Stainless prop(s)
- Trim tabs (w/twins)
- Power steering
- Power trim & lift
- Steering wheel (padded)
- Stereo AM/FM cassette, with remote, 60W equalizer, seek-scan, weatherband, 4 coaxial speakers, LED clock
- Systems monitor
- Aftcabin
- Bell hatch cabin entry**
- Canvas top & cockpit cover, color-coordinated
- Curtains in aft cabin
- Blinds (windows)
- Dinette table
- Engine synchronizer (twins)
- Fiberglass liner, (self-bailing)
- Galley: alcohol stove, ice box, sink, storage
- Head, portable, enclosed

- Seating: bucket seat (adjustable); L-shaped passenger seat
- Shower (pressurized)
- Sleeping for 4: aft cabin; vee-berth
- Storage: bow area; sidewall; under berth; floor
- Vanity/sink, enclosed
- Water inlet (dockside)
- Water storage (20 gal.)
- Winning Edge™ 3-Year Owner Protection*

Major Options

- Air conditioning
- Bow pulpit
- Convenience group
- Full canvas
- Radar arch
- Refrigerator
- Microwave oven
- "Vista" monogrammed bedding package

For a complete list of standard and optional features ask your dealer for the 255 Vista Feature Flyer

* Ask your Four Winns Dealer for full warranty details.
** Patent in process



An affordable entry to the world of live-aboard cruising.

Cockpit Seating

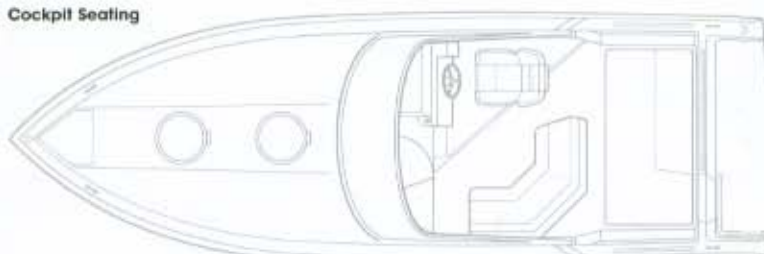

Cabin Interior

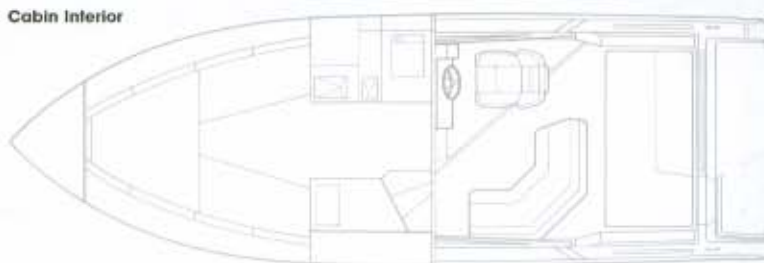

1. Cabin offers split galley and roomy dinette that converts to vee-berth sleeper.
2. Double berth aft cabin with privacy curtain.
3. Dash design with full instrumentation is unique to the 255 Vista.

Specifications:

LOA/Transom to Bow:	26'2"/24'5"
Beam:	8'6"
Boat Weight ¹ (lbs.)	w/340-HP I/O 6050 w/twin 200-HP I/O 6650
Fuel (gal.):	70
Water (gal.):	20
Power (HP):	Single 5.8U/235, 5.7U/260, 460CI/340 Twin 5.0L-HO/200
Passengers/Capacity (lbs.):	10/1400
Keel to Windshield:	98"
Freeboard:	Fwd. 38"; Aft 25"
Bridge Clearance:	7'2"
Draft:	39"

¹ Boat weight based on design estimate

AFFORDABLE FAMILY CRUISING



285 Vista instrumentation features systems monitor.

Live-aboard cruising is becoming an alternative to summer cottage living. The rustic cabin with limited amenities, shoehorned into an out-of-the-way forest does not match up well with the new breed of affordable and sophisticated mid-size cruisers moving into marinas and "dockominiums" across the country.

For a fair comparison from an investment standpoint, we're talking about cruisers from 24 feet to about 31 feet that are completely self-contained with full galley, head with shower; berths for a family of at least four and built in hook-ups



for dockside power, water, and head pumpout.

In short, that describes a lifestyle permitting the home and all the comforts that go with it... to go with you. Here's how some boaters we've talked to adapt to on board family living.

Typically, from about the first of July to Labor Day weekend, the family cruiser will occupy a rented or owned slip at a marina within an hour's drive of the principal residence. One or both parents may commute to their jobs during the week, returning to the marina each evening. Older children work summer jobs in the resort community, while younger children attend day camp, often provided by the marina management or by the Owners Association.

285 VISTA



Evenings, weekends and vacation time, the family is together aboard ship, socializing with neighboring boaters or taking day or more excursions to interesting nearby port o' calls.

It's an idyllic lifestyle that can provide excitement, adventure, romance, fond memories... and loving, lasting family ties.

Innovation brought the 285 Vista instant acclaim last year. A rotating passenger lounge... a pass-through window on the cabin bulkhead... split instrumentation to make it easier to monitor engine functions... "break through" styling with round hatches, a graceful sheer line and distinctive tri-tone color schemes.

This year there's more new thinking to separate the 285 Vista from the flotilla of "me too" cruisers out there. A fiberglass transom door with built in storage... A new mid-ship dinette that extends,

slides and folds ingeniously for storage and sleeping... a stern couch that extends for sunbathing... and stereo system remote controls at the helm. America's break-through wide bodies are at it again.

Major Std Features

- Anchor locker, bow
- Rails, 1" stainless
- Deck hatches, (2) round
- Nonskid walk around deck
- Swim platform, fiberglass, integrated w/adder
- Walk-through transom door w/storage
- Windshield, tinted/tempered, curved glass
- Adjustable helm seat
- Auto bilge pump
- Bilge blower
- Bilge, gel coat
- Bulkhead pass-through window
- Chart lighter
- Compass
- Counter rotating props
- Depth sounder
- Dockside power with battery charger/isolator/converter/cords/switch
- Dual battery switch
- Emergency engine shut off
- Hour meter
- Props, stainless

- Instrumentation: fuel, oil pressure; water temp; speedometer; tachometer; trim indicator; voltmeter; engine synchronizer
- Power steering
- Power trim & tilt
- Rotating L-shape passenger seat
- Steering wheel (padded)
- Stereo AM/FM cassette, with remote, 60W equalizer, seek-scan w/weatherband, & 4 coaxial speakers, LED clock
- Systems Monitor
- Trim tabs (hydraulic)
- Water inlet (dockside)
- Aft cabin
- Cabin windows w/blinds
- Sunbrella top & cockpit cover, color-coordinated
- Dinette (mid-cabin), (converts to berth)
- Enclosed head w/vac-u-flush toilet, vanity, sink, linen cabinets, mirror
- Fiberglass floor, self-bailing (cockpit)
- Full galley: alcohol/electric stove, 110/12V refrigerator, sink, storage
- Hanging storage
- Water heater
- Shower (pressurized), w/curtain
- Sleeping: aft cabin, dinette, vee-berth
- Storage: bow area; sidewalls; under berth, floor
- Winning Edge™ 3-Year Owner Protection*

Major Options

- Air conditioning
- Anchor windlass
- Full canvas
- Generator, 4kw
- Loran navigation
- Microwave
- Radar arch
- Ship to shore
- Transom wash-down w/shower
- Vista monogrammed bedding package

For a complete list of standard and optional features ask your dealer for the 285 Vista Feature Flyer

* Ask your Four Winns Dealer for full warranty details.



Head includes pressurized shower, vanity, sink, linen cabinets, mirror and vac-u-flush toilet.

Mid-ship Dinette



Mid-ship Salon



Specifications:

LOA/Transom to Bow:	28' 11" / 27' 5"
Beam:	10'
Boat Weight ¹ (lbs.) w/twin 200-HP engine:	9670
Fuel (gal.):	150
Water (gal.):	35
Power (HP):	Twin 5.0L-HO/200, 5.8L/235, 5.7L/260
Passengers:	12
Keel to Windshield:	9'
Freeboard:	fwd. 34"; aft 28"
Bridge Clearance:	7' 6" (with arch 9")
Draft:	33"

¹Boat weight based on design estimate



1. Home-on-water offers great convenience.

2. Fiberglass transom entry way has built in storage compartment.

3. Aft cabin sets up as dinette or double berth with privacy curtain.



AFFORDABLE FAMILY CRUISING

"It's lovely to live on a raft. We had the sky up there, all speckled with stars, and we used to lay on our backs and look up at them, and discuss whether they were made or only just happened."

—Huckleberry Finn

Samuel Clemens didn't realize it when he created that narrative, but he perfectly described one of the major tenets of the boater's creed.

Cruising is discovery in an elegant state. To leave home port in a seaworthy hull with a well stocked galley and family or boating friends aboard bound for an exotic port o'call... well, to some, that's about as perfect as boating can get.



The Grand Hotel on Mackinac Island in northern Michigan.



Port hopping can be one of the most enjoyable pursuits of the boating lifestyle. However, the pleasure can be heightened considerably when the journey is preceded by careful planning, and when the boat is properly equipped. Here are some proven check points:

315 VISTA

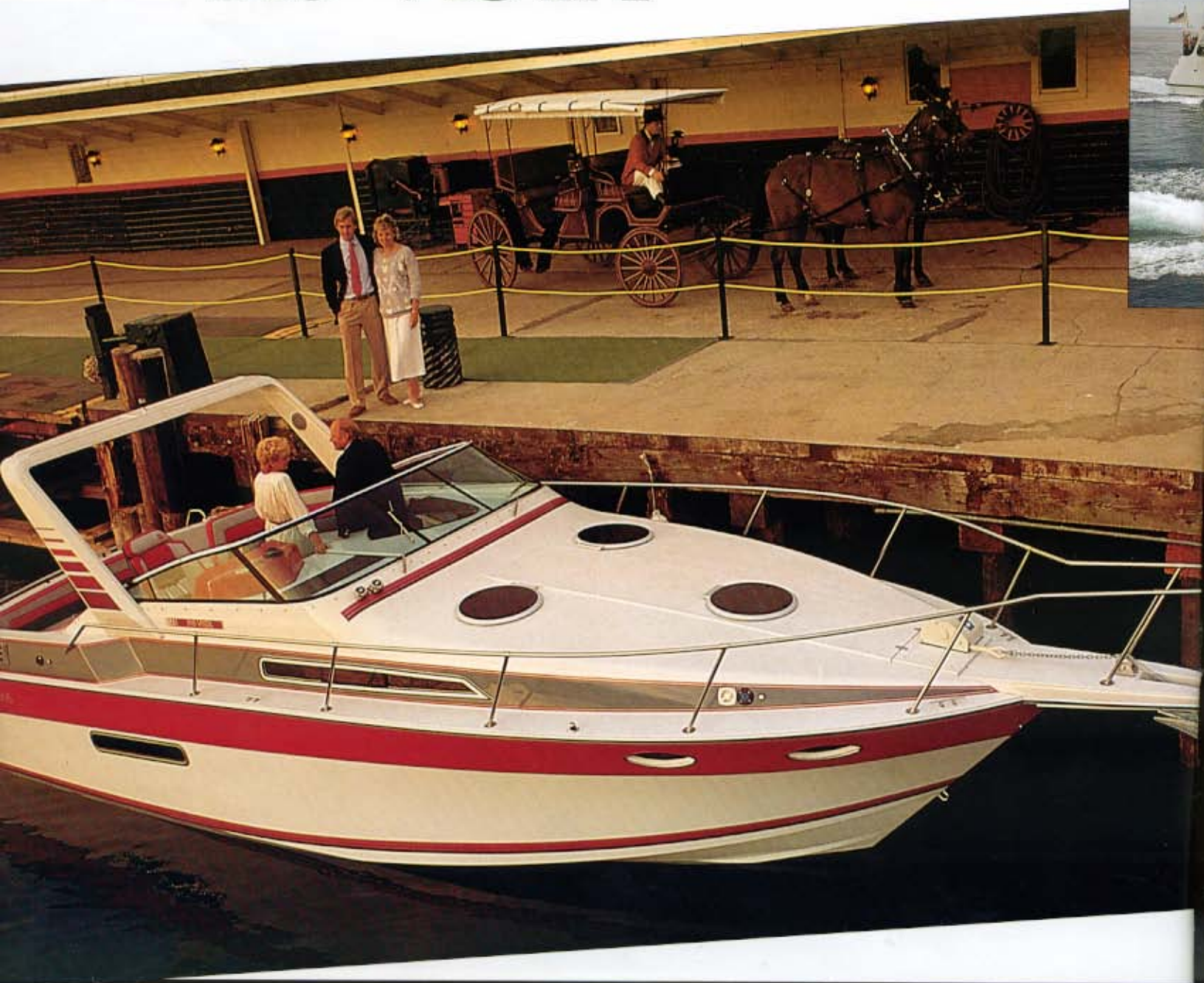

- Study your charts and plot a course before you leave home port.
- Check the condition of safety equipment on your vessel: Coast Guard approved PFDs for every passenger, fire extinguisher, signal flares, signal horn, first-aid kit, navigation lights, spotlight, ship to shore radio, depth sounder. (Radar is a highly desirable add-on.)
- Contact the harbor master at your point of destination several miles before arrival.
- Write down your destination, intended course, the names of passengers on board, the date and time of departure, and your estimated time of arrival. Leave the record with a friend that you will contact when you arrive in port.

The 315 Vista and 285 Vista (p.32) wide body cruisers share many feature and design advantages; like an exceptionally large integrated swim platform to extend live-aboard convenience; and the optional transom-mounted cockpit washdown system with showerhead. The luxurious 315 and 285



Tri-tone gel coat color scheme is complimented by available color-coordinated full canvas.

Vista cabin can accommodate six for extended cruising... two in the vee-berth, two in the mid-cabin and two in a full width aft cabin. Of course the big edge Vista cruisers have over all others is standard Winning Edge™ 3-Year Owner Protection Plan* covering hull and deck structural, powertrains and all major boat systems and components. It's boating's best protection and it's exclusively Four Winns.

Major Std Features

- Anchor locker, bow
- Rails, 1" stainless
- Deck hatches, (3) round
- Nonskid walk around deck
- Swim platform, integrated w/ladder
- Walk-through transom door w/storage
- Windshield, tinted/tempered, curved glass
- Adjustable helm seat
- Auto bilge pump
- Bilge blower
- Bilge, gel coat
- Bulkhead pass-through window
- Chart light/lighter
- Compass
- Counter rotating props
- Depth sounder
- Dockside power w/battery charger/isolator converter/cords & switch

- Emergency engine shut off
- Hour meter
- Power steering
- Power trim & tilt
- Rotating L-shaped passenger seat
- Steering wheel, padded
- Stereo AM/FM cassette, with remote 60W, equalizer, seek-scan w/weatherband, 4 coaxial speakers & LED clock
- Systems monitor
- Trim tabs, hydraulic
- Water inlet (dockside)
- Aft cabin
- Cabin windows w/blinds
- Sunbrella top, cockpit cover, color-coordinated
- Dinette (mid-cabin), (converts to berth)
- Enclosed head w/vac-u-flush toilet, vanity, sink, linen cabinets
- Fiberglass floor, self-balling (cockpit)
- Full galley, alcohol/electric stove, 110/12V refrigerator, sink, storage
- Hanging storage
- Water heater
- Shower (pressurized), w/curtain
- Sleeping: aft cabin, mid-cabin, vee-berth
- Storage: bow area; sidewalls; under berth; floor
- Winning Edge™ 3-Year Owner Protection*

Major Options

- Air conditioning
- Anchor windlass
- Full canvas
- Generator
- Loran navigation
- Microwave
- Radar Arch
- Ship to shore
- Television
- Transom wash-down w/shower
- Vista monogrammed bedding package

For a complete list of standard and optional features ask your dealer for the 315 Vista Feature Flyer

* Ask your Four Winns Dealer for full warranty details.



The 315 is sized and powered for extended big water cruising.

Mid-ship Dinette



Mid-ship Salon



Specifications:

LOA/Transom to Bow:	30' 6" / 29'
Beam:	11'
Boat Weight* (lbs.) w/twin 260-HP engine:	11,400
Fuel (gal.):	150
Water (gal.):	35
Power (HP):	Twin 5.7L/260, 460CI/340
Passengers:	12
Keel to Windshield:	10' 9"
Freeboard:	ftwd. 34"; aft 28"
Bridge Clearance:	7' 6" (w/arch 9')
Draft (Drives Down):	33"

* Boat weight based on design estimate



1. Full galley includes stove, refrigerator, sink and plenty of cabinet space. Optional microwave.

2. Very complete head includes linen cabinets, shower, vanity, sink, mirror

3. Vee-berth with optional "Vista" monogrammed bedding package.



THE SERIOUS SPORTFISHERMAN



A Lowrance depth finder comes standard on both CC and DC models.

On a brisk, breezy morning in early June a convoy of off-shore fishing boats clears the breakwater and heads out into Lake Michigan. The salmon are running early this year on the Great Lakes – a full month ahead of tournament time. Those who seek them as food or prize are ready for the hunt.

The last boat in line breaks from the pack heading south down the coast.

“Hey dad, how come we’re not following the charters?”, asked one of several boys on board.



To land a Chinook over 30 lbs. in these waters is the fantasy of every fisherman who tries... the thrill of a lifetime, like a hole in one, or bowling 300. The patient, savvy veteran knows what it takes.

Chinook, and the smaller but also prized King Salmon, feed on alewives, smelt and sculpin at depths where the water temperature is 52 to 54 degrees. So to have a shot at them you’ve got to know the depth, and match your bait to what they’re feeding on. Could be a J-plug, spoon, dodger, squid or combo.

“If you want to catch an *Oncorhynchus Tshawytscha*, you’ve got to think like an *Oncorhynchus Tshawytscha*”, said father, “and I’ve found him down this way before.”

The fish he was referring to is the Chinook...the ultimate prize of Great Lakes fishing.

207 QUEST CC/DC



Since boat traffic is usually heavy, the lure gets towed in a straight line. Frequent throttle changes can provide action to the lure, making it rise, fall and flutter temptingly.

If all the conditions are right, and the wily Chinook is in the mood...this could be the day you bag a trophy that thousands of fishermen consider to be the greatest prize in fresh water angling.

The beamy, yet trailerable 207 Quest™ Center Console (CC) and Dual Console (DC) models are the first fishing designs rugged enough

to be called Four Winns. Both feature hand lay-up fiberglass construction. Both are factory pre-rigged with Johnson® or Evinrude® V-6 outboards to 225-HP. Inside the self-bailing cockpit with washdown there's built-in

rod storage, an aerated oval baitwell and a five-foot fish box.

A Lowrance depth finder, and long-range 85-gallon fuel cell provide the capabilities to take you to your limit.

Like all Four Winns models, the 207 Quest CC and DC are covered by the exclusive Winning Edge™ 3-Year Owner Protection Plan*...boating's best protection. 

Major Std Features

- Anchor locker
- Aerated oval baitwell, 28 gallon
- Anchor locker
- Bilge pump (1500 gph)
- Bulk-head fold-down
- Concealed storage, 42 cubic feet
- Courtesy lights
- Dual cable steering
- Dual pedestal-mount helm chairs and cushions
- Fishbox, 5-foot
- Flush mounted controls (CC)
- Fuel tank, 85 gallon
- Canvas top
- Full instrumentation
- Hand lay-up 18 oz woven roven fiberglass construction
- Johnson® or Evinrude® outboard engine
- Large capacity portable ice chest
- Lifting eye
- Lowrance 1240A depth finder
- Recessed sidewall rod storage
- Self-bailing cockpit w/washdown
- Stainless steel steering wheel

- Walk-through windshield (DC)
- Welded stainless bow and grab rails
- Winning Edge™ 3-Year Owner Protection*

Major Option

- Hydraulic Steering

For a complete list of standard and optional features ask your dealer for the 207 Quest CC/DC Feature Flyer

* Ask your Four Winns Dealer for full warranty details



Standard canvas top provides protection from the sun. (shown: CC w/Bimini top)

207 Quest CC Floor Plan

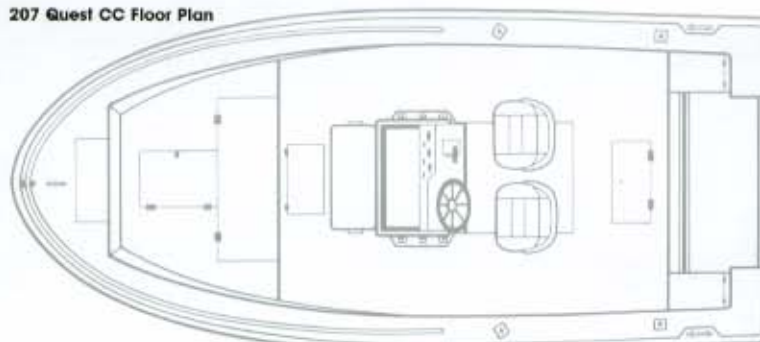

207 Quest DC Floor Plan

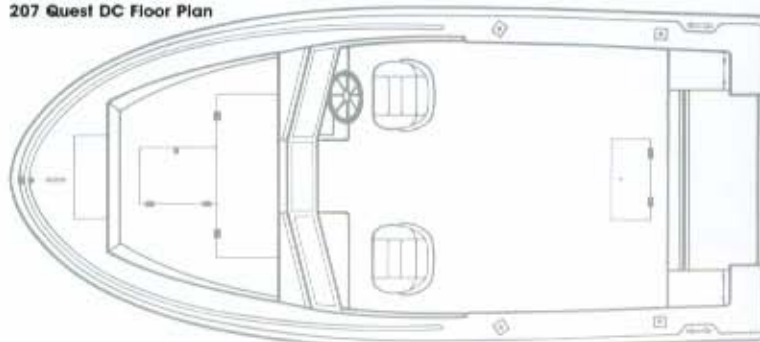

Specifications:

207 CC/DC

LOA	19' 10"
Beam	8' 4"
Boat Weight ¹ (lbs.) w/225-HP engine	2850
Fuel (gal.)	85
Power (HP)	(OB) 150, 175, 200, 225 Johnson® or Evinrude®
Passengers/Capacity (lbs.)	7/NA
Freeboard	28"

¹Boat weight based on design estimate
NA = Not Available



1. Power choices go all the way up to a 225-HP Johnson® or Evinrude® outboard.

2. 207 Center Console has flush mounted, bimini controls.

3. 207 Dual Console is functional, attractive and easy to monitor.

THE SERIOUS SPORTFISHERMAN



Plenty of dash space
for add-ons.

Survival Tactics for the Fishing Family

I grew up in a household headed by a "golf widow". Needless to say, I vowed not to marry a golfer. But mama never told me about fishermen. I didn't learn of the species until "the honeymoon."

Oh sure, I knew he fished (First date: ME: "Hmmm... what a — peculiar cologne. What's it called?" HE: "Bug juice and sun screen."), but I didn't recognize the crisis until that first morning when we rolled out of the sack (read



"sleeping bag") an hour before first light. The playful groping I had fantasized about turned into muscling the canoe off the top of "our" 4 x 4.

Several wordless hours later, in the middle of a hot, quiet, empty lake, I accepted my destiny.

"OK...", I said in my best pout, slapping the back of my neck, "pass the bug juice and hand me my pole."

"Rod.", he corrected.

All that happened several years ago and a couple of little fisherpersons ago. Today, I'm proud to tell mama I'm not a fishing widow.

Along the way I've developed simple, but effective survival tactics designed to make the best of the family fishing lifestyle.

1. "You clean, I cook... or... you clean, you cook", end of conversation!

267 QUEST

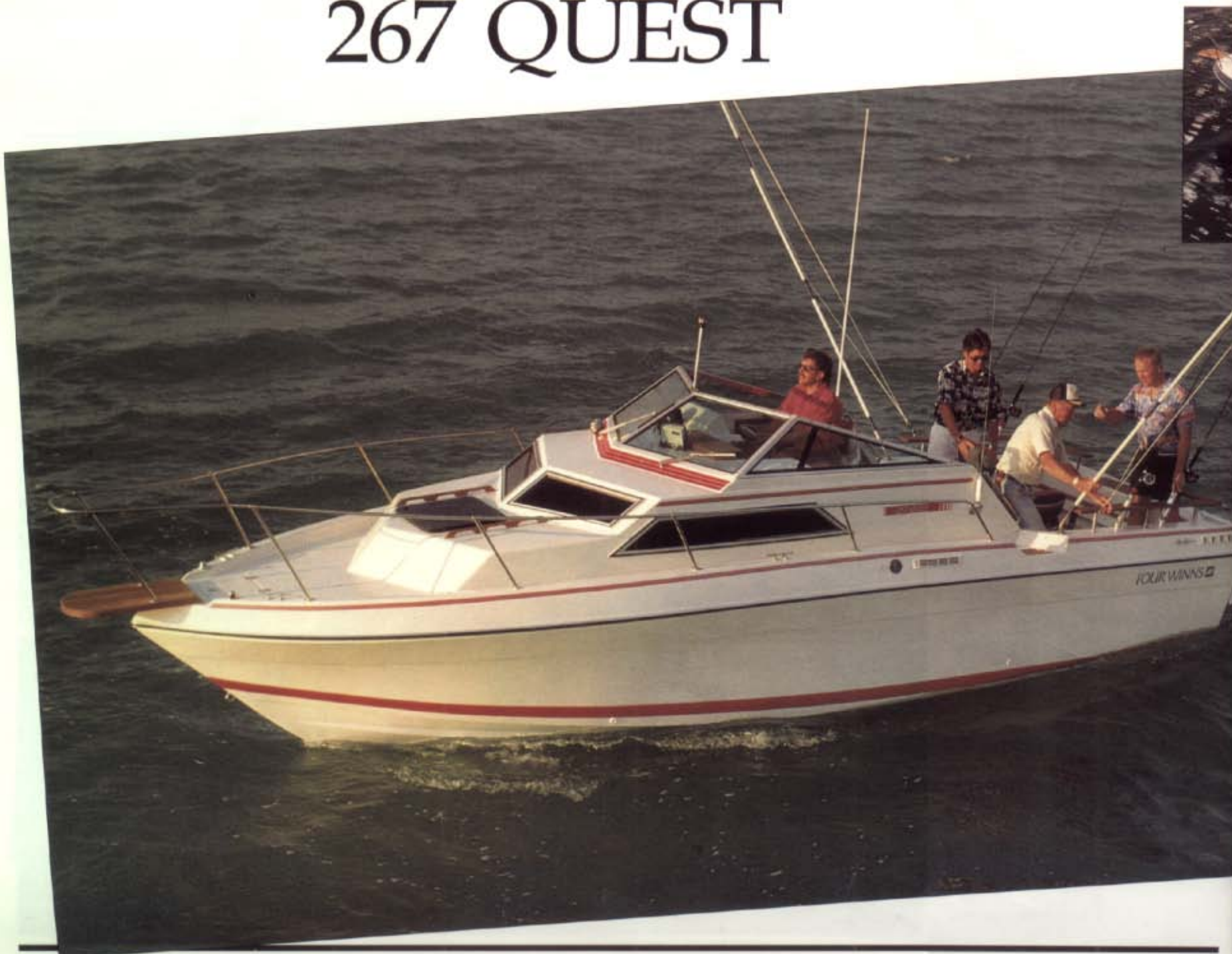

2. For every two nights on the water, one in a motel with pool, spa, restaurant, and lounge with live entertainment.

3. Minimum fishing boat requirements: Full canvas, cuddy cabin with enclosed head, full galley, separate and private sleeping quarters for adults, kids...and mama!

— Anonymous



Self-bailing fiberglass cockpit liner includes washdown.

The 267 Quest™ has all the attributes of a serious sportfisherman. The stern is broad, deep and flat for easy movement. Wide teak stern rails are ready to accept downriggers. Rod storage, multiple fishwells, depth sounder and fiberglass cockpit floor with washdown are all standard.

A 100-gallon fuel cell and a reliable 260-HP OMC Cobra® stern drive provide long-range cruising capability. New this year is the availability of twin 140-HP OMC Sea Drives®.

A comfortable cabin sleeps three in the vee-berth and in a single mid-ship bunk to port. Enclosed head and galley with sink, ice box and single burner alcohol stove provide live aboard convenience for the 267 Quest.

Major Std Features

- Anchor locker
- Bow pulpit
- Rails, stainless
- Cleats (6) stainless
- Deck hatch
- Gel coat, two tone
- Nonskid walk around deck
- Swim platform, fiberglass
- Transom light
- Windshield, tinted/tempered, with vented wings
- AM/FM antenna w/noise suppressor
- Aluminum fuel tank, (100 gal.) in-floor
- Auto bilge pump
- Bilge blower
- Prop, stainless

- Bilge, gel coat
- Depth sounder
- Emergency engine shut off
- Hour meter
- Instrumentation: fuel; oil pressure; water temp.; speedometer; tachometer; trim indicator; voltmeter.
- Power steering
- Power trim & tilt
- Remote oil filter
- Steering wheel (padded)
- Stereo AM/FM cassette, 60W equalizer, seek-scan w/weatherband, 4 coaxial speakers & LED clock
- Trim tabs, hydraulic
- Bail well
- Cabin lights
- Cabin door, teak, w/hasp
- Carpeting, cabin
- Canvas top
- Courtesy lights
- Curtains (windows)
- Dinette table
- Fishwell
- Fiberglass liner (self-bailing)
- Galley; alcohol stove, 1-burner, ice box, sink, storage

- Glove box
- Hanging locker
- Head, portable, enclosed
- Seating: bucket seats adjustable
- Sleeping: mid ship berth; vee-berth
- Storage: bow area; sidewall; under berth; fishing rod
- Washdown system
- Windows: front cabin; side w/screens

Major Options

- Full canvas
- Fighting chair
- Ship to shore
- Loran navigation w/antenna
- Dockside power

For a complete list of standard and optional features ask your dealer for the 267 Quest Feature Flyer

* Ask your Four Winns Dealer for full warranty details.

Specifications:

LOA:	26'
Beam:	8'
Boat Weight [†] (lbs.): w/260-HP engine	5200
w/twin 140-HP OMC Sea Drives	5320
Fuel (gal.):	100
Water (gal.):	15
Power (HP):	Twin 140-2L OMC Sea Drives® Single 5.7L/260
Passengers/Capacity (lbs.):	10/1410
Keel to Windshield:	96"
Freeboard:	ftwd. 47", aft 22"
Bridge Clearance:	6'8"
Draft:	31"

[†]Boat weight based on design estimate

267 Quest rigged for serious angling with optional fighting chair.

Standard Seating

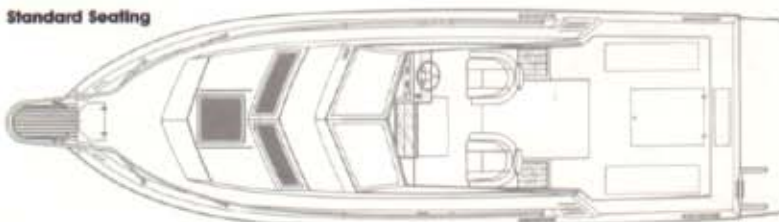

Cabin Interior



1. Twin OMC Sea Drives are a new availability with standard bow pulpit, non-slip walk-around, rod holders, and fishwells. The 267 is a serious sportfisherman.

2. Quest's comfortable cabin has sleeping for three.

3. Full instrumentation puts switches and gauges at your fingertips.



HIGH PERFORMANCE AND PRACTICALITY CAN COEXIST



The power of OMC!

"Boat and skier approach the ramp... the skier banks sharply to increase speed ... he's up... over... perfect landing!"

Whether you're flying, standing, sitting or on your knees... as a water sports enthusiast you can expect a wet and wild ride on today's water toys which include skis, boards, tubes, sleds, logs, torpedoes, bobbars and sundry other towables.

They're loads of fun, easy to store on board, and the price range is wide, so there's something for every budget.



The speed and handling of the boat depends on the towing action. "Barefooters" need plenty of speed and a straight line course.

Slalom and trick skiers like a steady pull between 28 and 32 mph.

When towing inflatables, the boat driver should always start slowly with 50 to 75 feet of tow rope in a straight line behind the boat.

Accelerate evenly to a moderate speed (20 mph or less).

Remember, the rider cannot steer these toys. Riding an inflatable is exciting, doesn't require a lot of

skill, and can be enjoyed by all ages. A "tube" looks like a large doughnut, while "sleds", "torpedoes" and "bobbars" bounce along like long air-filled cigars. For more challenge there's also the kneeboard which resembles a squat surfboard. It's closest to skiing in terms of skill and technique.

Few activities equal the thrill of being tethered to a sleek, spirited sportboat. If an invigorating ride or a sultry day sounds appealing, make this the year you spend time behind a boat on the towable of your choice.

201 LIBERATOR

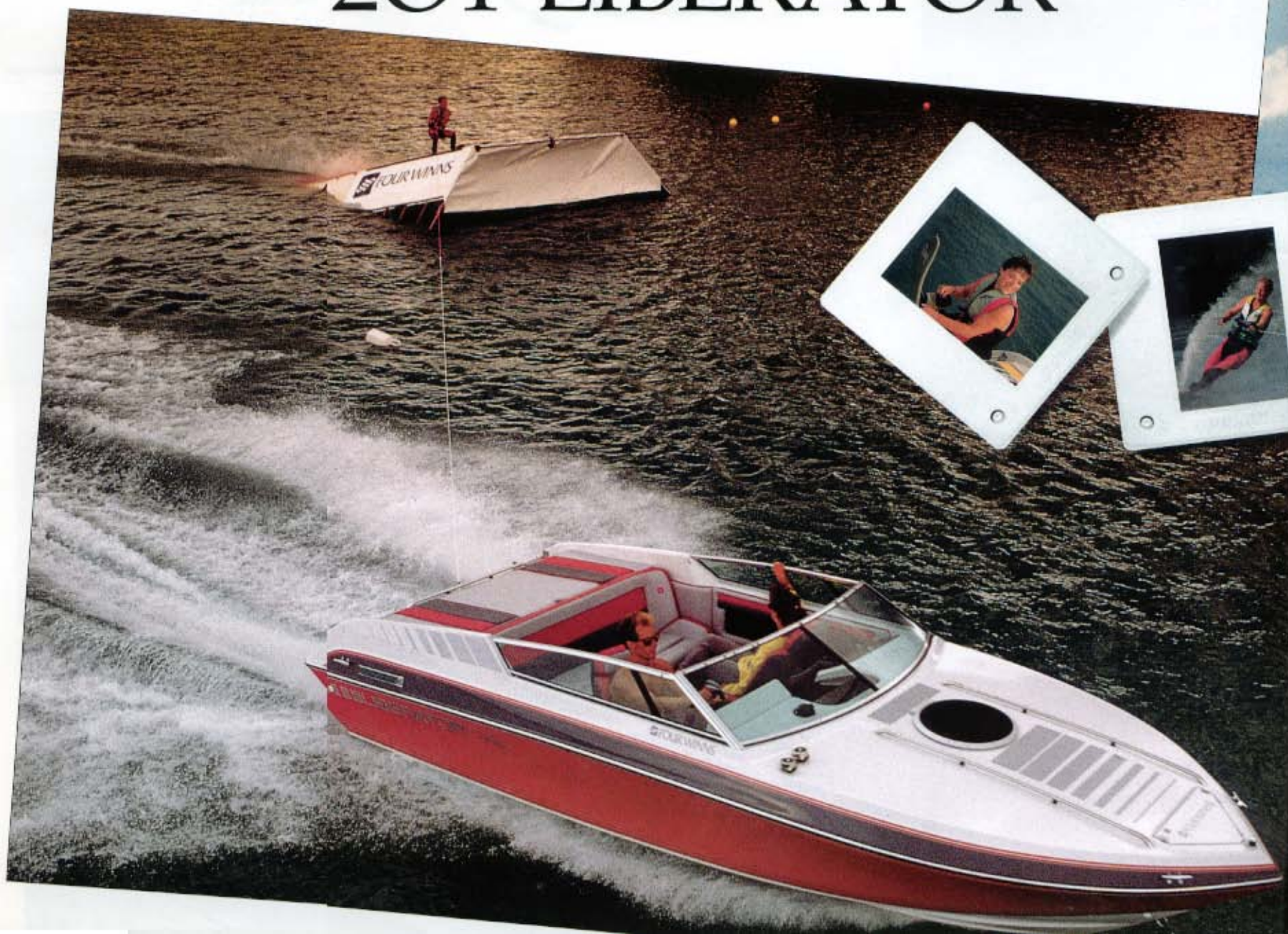

Remember, always observe safe towing practices. Have a "lookout" in the boat with the driver. Stay clear of swimmers, other boats and in-water hazards. Use Coast Guard approved flotation vests (It's the law!). Supervise children.



Stainless ski eye is standard

If the 201 were anything but a Liberator®, it would have an identity crisis. But by design, it's an elegant blend of spirited performance and welcome practicality.

The performance identity stems from the availability of up to a 270-HP OMC King Cobra® stern drive with stainless prop. The theme plays even stronger in

the sleek new limited edition 201 Liberator 2+2 Signature Series.

Give the 201 high marks for practicality with its easy-access cabin, generous storage, electric lift sundeck/engine hatch, and full-width stern couch.

And how many other performance boats offer standard Winning Edge™ 3-Year Owner Protection?*



New signature Series 201 2+2 Liberator offered in limited edition.

Major Std Features

- Anchor locker, bow
- Rails, stainless
- Cleats (4)
- Deck hatch, round
- Exhaust, thru prop
- Gel coat, three tone
- Prop, stainless
- Ski eye, stainless
- Swim platform, w/ladder
- Trailer, tandem axle, color-coordinated
- Windshield, tinted/tempered, bent glass, with vented wings
- AM/FM antenna w/noise suppressor
- Aluminum fuel tank, (44 gal.) in-floor
- Bilge blower
- Bilge, gel coat
- Depth sounder
- Emergency engine shut off
- Engine hatch, electric assist with mirror
- Instrumentation: fuel; oil pressure; water temp.; speedometer; tachometer; trim indicator; voltmeter
- Power steering
- Power trim & tilt
- Steering wheel (padded)

- Stereo/AM/FM cassette, 60W equalizer, seek-scan, w/weatherband, 4 coaxial speakers & LED clock
- Canvas top, cockpit cover, color-coordinated
- Ice chest, integrated
- Seating: cushioned aft sundeck; custom molded bucket seats (adjustable); wrap-around stern couch; vee-berth cushions
- Sleeping for 2 vee-berth
- Storage: bow area, sidewall; under berth; engine compartment
- Winning Edge™ 3-Year Owner Protection*

Major Options

- Full canvas
- Exhaust, thru-hull w/mufflers
- Fiberglass cockpit liner
- Swim platform, teak insert

For a complete list of standard and optional features ask your dealer for the 201 Liberator Feature Flyer

* Ask your Four Winns Dealer for full warranty details.



Action is wet and wild behind a spirited powerboat.

Standard Seating

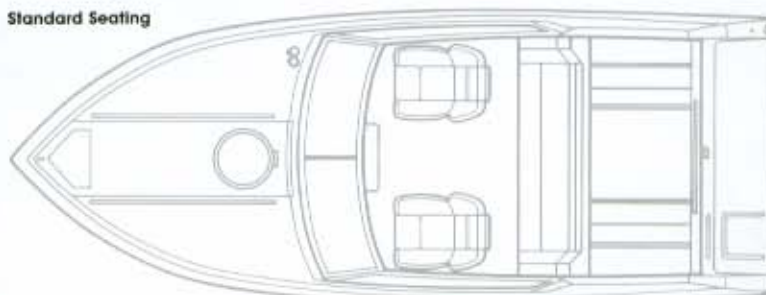

Cabin Interior

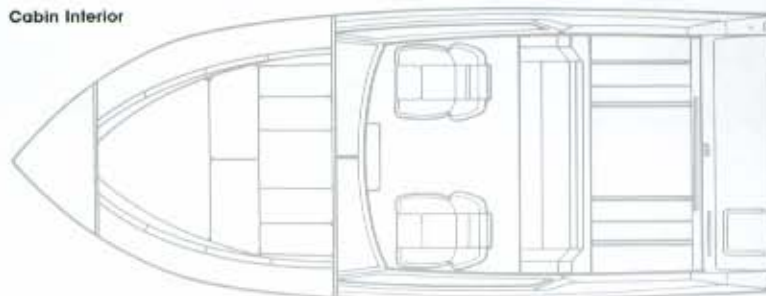

Specifications:

LOA/Transom to Bow:	20'9" / 19'4"
Beam:	7'8"
Boat Weight ¹ (lbs.) w/270-HP I/O:	3060
Fuel (gal.):	44
Power (HP):	5.0L/200, 5.7L/260, 350CI/270
Passengers/Capacity (lbs.):	8/1160
Keel to Windshield:	64"
Freeboard:	33"

¹ Boat weight based on design estimate



1. Cockpit design features: ergonomically engineered seating, coaming board storage, integrated instrument housing, atrium style plexiglass cabin entry
2. Vee-berth with fill-in cushions, indirect lighting and canted seats.
3. The 201 dash, never a dull moment.

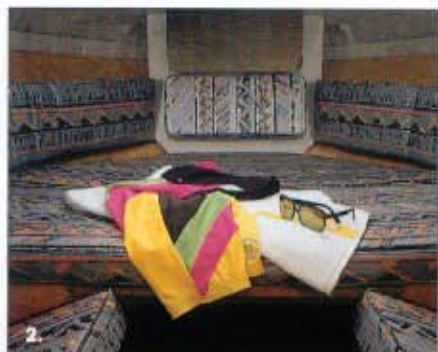

HIGH PERFORMANCE AND PRACTICALITY CAN COEXIST



Standard AM/FM
stereo cassette w/
weatherband.

There's nothing quite so awe-inspiring as a long, lean sophisticated performance boat. It quickens the pulse even when it's just standing still. Like a thoroughbred... sleek... poised... ready to leap to action with the nudge of its throttle.

Many owners of spirited powerboats have a special relationship with their craft. They keep the muscular flanks clean and glistening. They tune the powerplant to peak efficiency. They let no one at the reins but themselves.



Along with the right to own and run a spirited performance boat goes the obligation to respect the rights of other boaters. Knowing when, for example, to hold back the thunderous engines to a muffled whisper is a mark of character in a boater.

The presence of a lean, fast machine is often intimidating to a boater with less power. That's a situation that requires the performance boat owner to make extra efforts in reassuring fellow boaters.

Good boating manners are paramount for performance boat owners, for they are always being judged by their actions.

Taking extra care to minimize the wake in restricted areas... or cutting back on the throttle (and engine noise) in high traffic, or in proximity to cottage dwellers can be reassuring and a sign of good faith that builds good relationships.

211/241 LIBERATOR



Being a responsible, considerate boater when others are around will make those special times more exhilarating and rewarding... when the water looms long, silent and empty ahead, and it's safe to let the throttle out... and let the beast run.



The essence of the Liberator® series is performance. It shows in the classic attitude of the 211 and 241 models. Both are powered by muscular OMC King Cobra® V-8 stern drives (twins available on the 241) with stainless prop(s). Thru-hull exhaust with mufflers is available.

As you might expect, sporty contoured swivel buckets, stern couch and power operated sundeck/engine hatch are included. Premium sound system, depth sounder, tach and full gauges are standard, of course.

But perhaps unexpectedly, the 211 and 241 Liberator also provides enormous storage space and roomy, easy-access cuddy cabins.

So you see, high performance and practicality can coexist.

211/241 Liberator Major Std Features

- Rails, stainless
- Cleats (4-211, 6-241)
- Deck hatch, round
- Exhaust, thru prop
- Gel coat, three tone
- Prop, stainless
- Ski eye, stainless
- Swim platform, full teak, w/ladder
- Trailer, tandem axle, color-coordinated
- Windshield, tinted/tempered, with vented wings
- AM/FM antenna w/noise suppressor

- Aluminum fuel tank, in-floor
- Auto bilge pump
- Bilge blower
- Bilge, gel coat
- Depth sounder
- Emergency engine shut off
- Engine hatch, electric assist, w/mirror
- Instrumentation: fuel, oil pressure, water temp.; speedometer; tachometer; trim indicator; voltmeter.
- Power steering
- Power trim & tilt
- Steering wheel (padded)
- Stereo AM/FM cassette, 60W equalizer, seek-scan w/weatherband, 4 coaxial speakers & LED clock
- Cabin door w/hasp, teak
- Carpeting
- Canvas top and cockpit cover, color-coordinated
- Chart lighter
- Courtesy lights
- Engine compartment lights
- Ice chest
- Indirect lighting, cabin

- Seating: cushioned aft sundeck; custom molded bucket seats (adjustable); wrap-around stern couch; vee-berth cushions
- Sleeping for 2: vee-berth
- Storage: bow area; ski; engine compartment; concealed top
- Winning Edge™ 3-Year Owner Protection*

Major Options

- Full canvas
- Exhaust, thru-hull w/mufflers
- Swim platform, fiberglass
- Trim tabs, hydraulic (std. w/twins)

For a complete list of standard and optional features ask your dealer for the 211 and 241 Liberator Feature Flyers

* Ask your Four Winns Dealer for full warranty details.



The high performance Liberator series is available with optional thru hull exhaust w/mufflers.

Standard Seating (211)

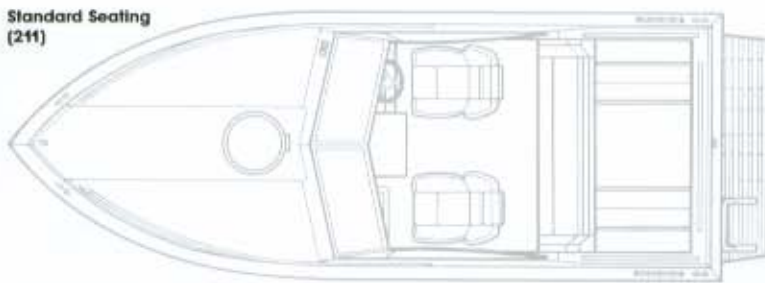

Cabin Interior (211)

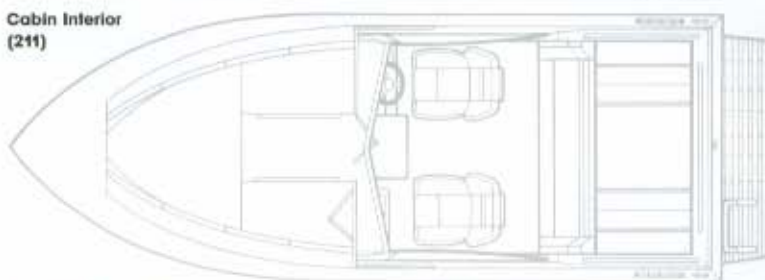

Specifications:	211	241
LOA:	21'	23'8"
Beam:	8'	8'6"
Boat Weight ¹ (lbs.):		
w/270-HP engine	3260	5030
w/340-HP engine		5640
w/twin 270-HP		
Fuel (gal.):	44	100
Power (CV/HP) Single:	350CV/270	460CV/340
Twin:	460CV/340	350CV/270
Passengers/Capacity (lbs.):	8/1160	10/1410
Keel to Windshield:	66"	77"
Freeboard:	35"	38"

¹Boat weight based on design estimate



1. The classic design of the 241 Liberator, with full teak swim platform and multi-level helm, combines power, space and utility.
2. A round hatch provides a distinctive styling note and natural lighting to the 211 Liberator vee-berth below.
3. Everything the performance driver needs is incorporated in the 211 Liberator helm.



HIGH PERFORMANCE AND PRACTICALITY CAN COEXIST

Boating is for the most part a safe, healthy, satisfying pursuit that brings pleasure and joy to its participants.

Statistically, boaters are responsible and careful in the use of their craft. The serious accident rate per thousand boaters is significantly lower than the rate for car and truck drivers or motorcycle operators.

There is however, one area of serious abuse that needs to be ad-



Bow locker stows line and anchor.



dressed by the marine industry and by all boaters.

According to the U.S. Coast Guard, alcohol is a factor in

more than half of all boating accidents occurring annually.

When you understand that the effects of alcohol are different for boat operators than for the operators of other types of vehicles, it's easy to see that drinking and operating a boat don't mix.

Research has shown that under the stresses of operating a boat on

open water — wind, sun, the physical demands — it takes one third as much alcohol to cause impaired judgement and motor skills as it would for the same person when on land.

It has also been demonstrated that alcohol enters the blood stream of the active boater faster than for someone drinking in a bar or at home.

When you consider that it is socially acceptable to have a drink on a boat even in the early hours, it's easy to see that boaters who drink are at risk to themselves and other boaters.

251 LIBERATOR

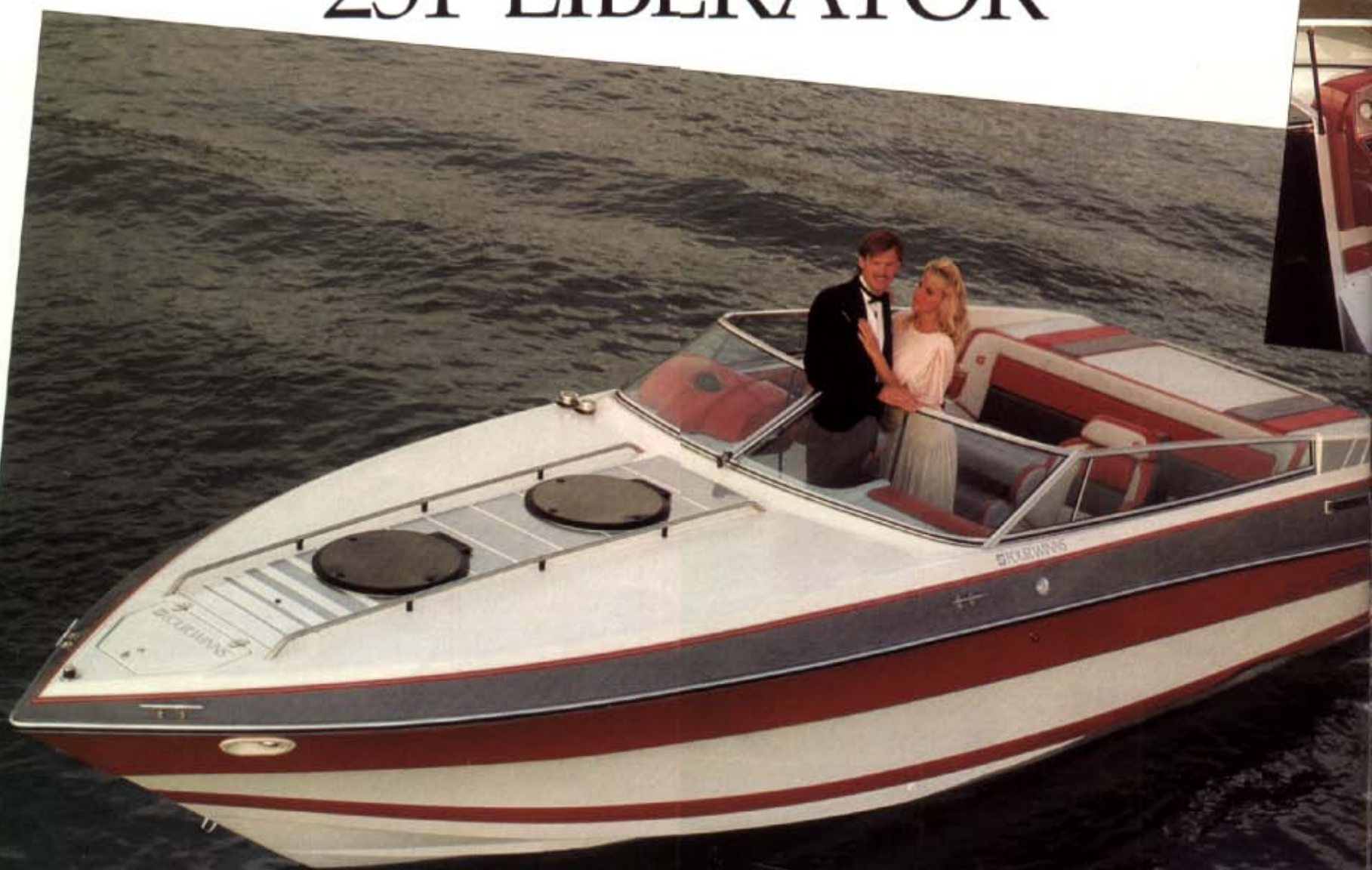

Boating should be fun and safe for everyone. We can all help make it that way by using good judgment:

- Don't drink and operate a boat.
- Don't let anyone who has been drinking operate a boat.
- When drinking will be a part of a boating activity, choose a designated non-drinking helmsman.



The 251 is the newest edition of the awesome Liberator® performance series... 26-feet, 2-inches of power and grace (including stylish integrated swim platform) on a trailerable eight and-a-half-foot beam.

A 340-HP OMC King Cobra® stern drive in single engine configuration or twin 270-HP versions (with counter-rotating stainless props) assure that the 251 will live up to the Liberator heritage. Enthusiasts will also appreciate the availability of thru-hull exhaust with mufflers, and driver

and passenger power bolster seats. In keeping with the Liberator tradition that combines utility and performance, the 251 offers a very usable cabin with wet bar, sink, ice box, vee-berth, portable head and mood lights.

Major Std Features

- Anchor locker, bow
- Rails, stainless
- Cleats (6) stainless
- Deck hatches (2), round
- Exhaust thru prop
- Gel coat, three tone
- Prop, stainless
- Ski eye, stainless
- Swim platform, fiberglass, integrated w/ladder
- Transom light
- Windshield, tinted/tempered curved glass
- AM/FM antenna w/noise suppressor
- Aluminum fuel tank, (100 gal.) in-floor
- Auto bilge pump
- Bilge blower
- Bilge, gel coat
- Compass
- Depth sounder
- Emergency engine shut off
- Engine hatch electric assist w/mirror
- Instrumentation: engine synchronizer (twins); hour meter; fuel; oil pressure; water temp. gauges; speedometer; tachometer; trim indicator; voltmeter.
- Systems monitor
- Power steering
- Power trim & tilt
- Prop(s), stainless
- Steering wheel (padded)
- Stereo AM/FM cassette, with remote, 60W, equalizer, seek-scan w/weatherband, 4 coaxial speakers, remote LED clock
- Cabin door w/hasp, plexiglass
- Carpeting, cabin
- Canvas top and cockpit cover, color-coordinated
- Chart light/lighter
- Courtesy lights
- Dinette table
- Trim tabs, hydraulic

- Engine compartment lights
- Head, portable
- Indirect lighting, cabin
- Seating: cushioned aft sundeck; custom molded bucket seats (adjustable); wrap around stern couch; vee-berth cushions
- Sleeping for 2: vee-berth
- Storage: bow area; sidewall; under berth; engine compartment; concealed top
- Water storage (15 gal.)
- Winning Edge™ 3-Year Owner Protection*

Major Options

- Full canvas
- Exhaust, thru-hull w/mufflers
- Swim platform, teak insert
- Refrigerator

For a complete list of standard and optional features ask your dealer for the 251 Liberator Feature Flyer

* Ask your Four Winns Dealer for full warranty details.



Custom molded power bolster seats (optional) have good side and back support.

Standard Seating

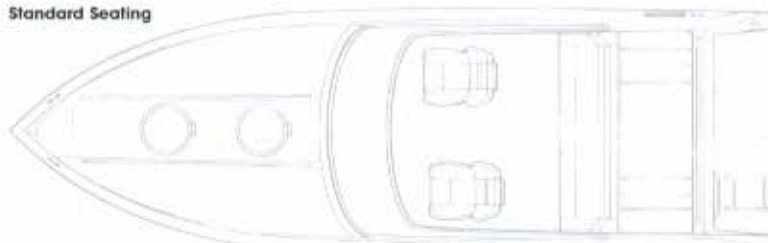

Cabin Interior

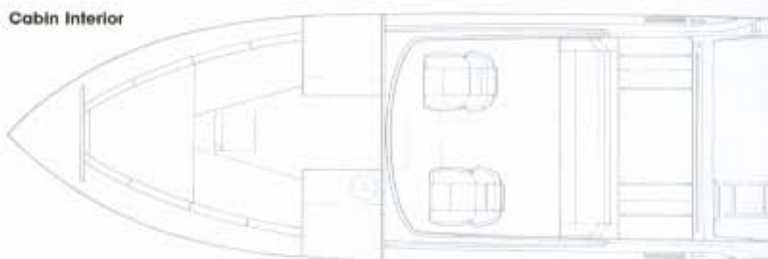

Specifications:

LOA:	26'2"
Beam:	8'6"
Boat Weight ¹ (lbs.) w/twin 270-HP engine:	5680
Fuel (gal.):	100
Water (gal.):	20
Power (HP):	Single 460CI/340 Twin 350CI/270
Passengers/Capacity (lbs.):	10/1400
Keel to Windshield:	75"
Freeboard:	38"

¹Boat weight based on design estimate



1. Sporty, practical and trailerable, the 251 is available with single or twin OMC King Cobra® power.
2. Two large round hatches light up the cabin below.
3. Cabin includes partial galley with work surface, sink and ice box.



HIGH PERFORMANCE AND PRACTICALITY CAN COEXIST



The 261 helm is distinctly performance oriented.

Boating for some is most exciting, most satisfying when alone on familiar waters, void of other boats, piloting a sleek, spirited performance craft... the surface calm... the day bright and warm... hand at the throttle of mega-horsepower.

For others, leisurely cruising offshore at mid-range RPMs is most comfortable.



Still others find the most enjoyment not so much in being on the water, as in visiting different ports.

Part of the great attraction of boating is that it accommodates so many lifestyles. In order to pursue their passion however, all boaters share the responsibility of safe navigation, especially when entering or leaving port.

The "Rules of the Road", as outlined by the Inland Navigation Act of 1980, govern navigation on lakes, streams and intercoastal waterways, where more than 95% of America's pleasure boating takes place. All helmsmen should occasionally review them:

1. **Warning Signals:**
 - One short horn blast *
Changing course to starboard.
 - Two short horn blasts **
Changing course to port.
 - Three short horn blasts ***
Operating astern
 - Five or more short horn blasts *****
Repeat signal, or danger signal

2. Overtaking Maneuvers

A. Give-way vessel announces intention to overtake stand-on vessel to port or starboard with appropriate horn signal.

B. Give-way vessel waits for same signal response from stand-on vessel.

C. Give-way vessel completes agreed upon maneuver.



261 LIBERATOR

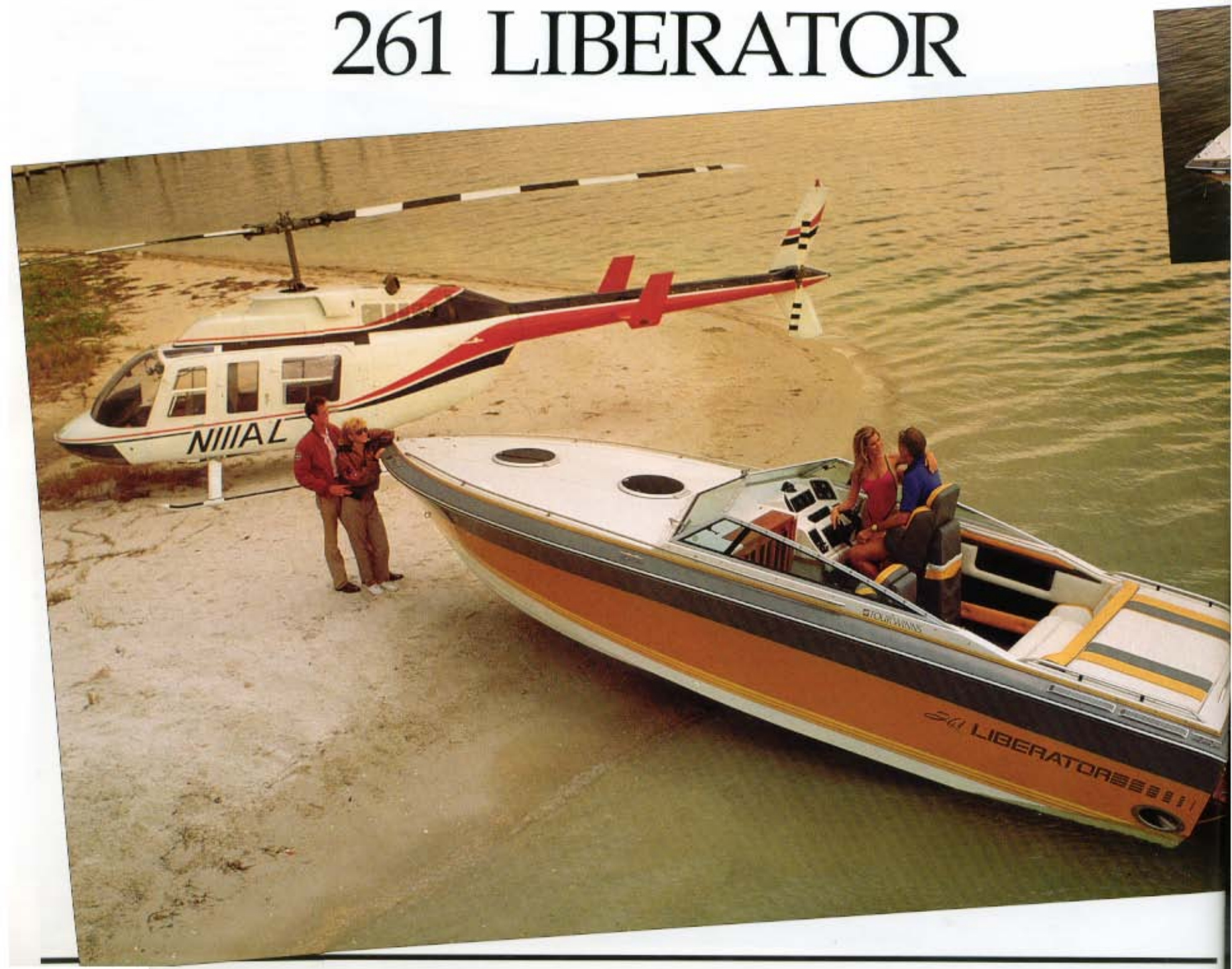

3. Head On Maneuvers

A. In a narrow channel, both vessels must give way.

B. Either vessel signals and maneuvers to starboard.

C. Responding vessel also maneuvers to starboard with signal reply.

4. Crossing Maneuvers

A. The give-way vessel has the other vessel on its starboard (right) side. Give-way vessel must maneuver to starboard if necessary after appropriate signal.

B. The stand-on vessel returns signal and maintains course.



The long, lean, tri-tone fuselage... the distinctive round deck hatches... the classic silhouette... the instant you notice them you know the 261 Liberator® is loose. If you ever have the opportunity to test drive or even ride in a 261 Liberator, don't miss it. At the helm and passenger positions optional power bolsters surround you. Fire up the twin 270-HP or 340-HP OMC King

Cobra® stern drives with counter rotating stainless steel props.

Optional thru-hull exhaust with mufflers speak the performance language. Ease the sophisticated deep-vee through the no wake zone. Once you've cleared the buoys and a smooth and empty expanse of water stretches before you... punch it... Experience the adventure of your life!

Major Std Features

- Anchor locker, bow
- Rails, stainless
- Cleats (6) stainless
- Deck hatches (2) round
- Exhaust, thru prop
- Gel coat, three tone
- Props, stainless
- Ski eye, stainless
- Swim platform, full teak, w/ladder
- Transom light
- Windshield, tinted/tempered w/vented wings
- AM/FM antenna w/noise suppressor
- Aluminum fuel tank, in-floor

- Auto bilge pump
- Battery switch (dual)
- Bilge blower
- Bilge, gel coat
- Compass
- Depth sounder
- Emergency engine shut off
- Engine hatch, electric assist w/mirror
- Instrumentation; engine synchronizer; hour meter; fuel, oil pressure; water temp. gauges; speedometers; tachometers; trim indicators; voltmeters
- Power steering
- Power trim & tilt
- Steering wheel (padded)
- Stereo AM/FM cassette, 60W, equalizer, seek-scan w/weatherband, 4 coaxial speakers & LED clock
- Trim tabs, hydraulic
- Cabin door w/hasp, teak
- Carpeting
- Canvas top and cockpit cover, color-coordinated
- Chart light/lighter
- Courtesy lights
- Curtain in vee-berth
- Dinette table
- Engine compartment lights

- Head, portable
- Indirect lighting, cabin
- Seating; cushioned aft sundeck; custom molded bucket seats (adjustable); wrap around stern couch; vee-berth cushions
- Sleeping for 4; dinette converts to berth; vee-berth
- Storage; bow area; sidewall; under berth; ski; engine compartment; concealed top
- Water storage (15 gal.)
- Wet bar w/ice box, decanters, glasses
- Winning Edge™ 3-Year Owner Protection*

Major Options

- Bolster seats, power
- Full canvas
- Exhaust, thru-hull w/mufflers
- Refrigerator

For a complete list of standard and optional features ask your dealer for the 261 Liberator Feature Flyer

* Ask your Four Winns Dealer for full warranty details



The largest Liberator features the performance of up to 340-HP OMC King Cobra® stern drives.

Standard Seating

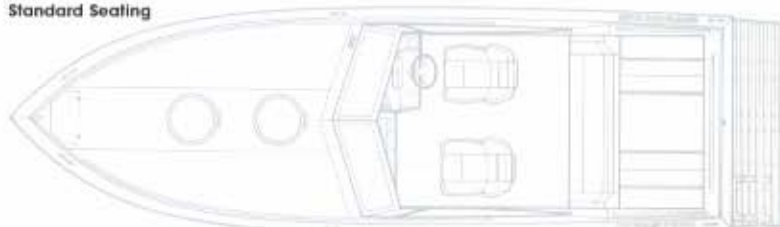

Cabin Interior

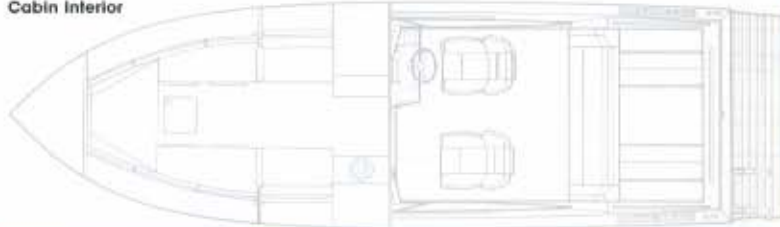

1. The classic lines of the 261 Liberator bear a sophistication no other can touch.
2. Four can dine or sleep in the accommodating cabin.
3. Partial galley includes sink and ice box... storage as well.

Specifications:

LOA:	26'
Beam:	8'
Boat Weight ¹ (lbs.) w/twin 340-HP engine:	6500
Fuel (gal.):	100
Water (gal.):	15
Power (HP):	Twin 350CI/270, 460CI/340
Passengers/Capacity (lbs.):	10/1410
Keel to Windshield:	75"
Freeboard:	37"

¹Boat weight based on design estimate

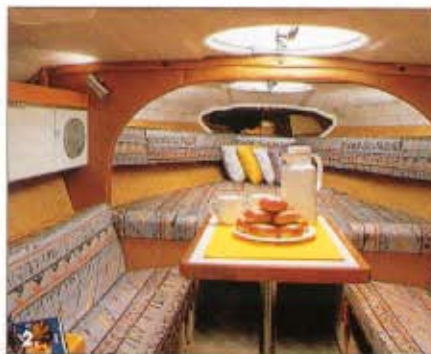

COLORS/OPTIONS/ ACCESSORIES

All Four Winns models are complete and ready for use the day they are put in the water. However, we recognize that there are many applications that Four Winns boats can fulfill. Shown or described on these pages are a wide range of colors, options, and accessories designed to contribute comfort and convenience, enhance the value, extend the utility, and/or add to your enjoyment while boating. For a complete list of availabilities see your Four Winns Dealer.

- = available
- = standard
- = included in SLX pkg
- = convertible model
- = w/OMC Sea Drives only
- = not available

	160 Freedom	160 Freedom	170 Freedom	160 Freedom	165 Freedom	180 Horizon	200 Horizon	210 Horizon	180 Condo	200 Condo	205 Sundowner	215 Sundowner	225 Sundowner	235 Sundowner	245 Vista	255 Vista	315 Vista	207 Quest CC	207 Quest DC	207 Quest	201 Liberator	201 2+2 Liberator	211 Liberator	241 Liberator	251 Liberator	261 Liberator		
AVC & HEATING																												
ALCOHOL STOVE, 1 BRNR																												
ALCOHOL/ELEC. STOVE																												
ANCHOR W/ LINE																												
AUTO BILGE SWITCH																												
BEDDING PACKAGE																												
BOW PULPIT																												
BROUGHAM INTERIOR (BI)																												
CANVAS AFT																												
CAMPER																												
COCKPIT COVER																												
FORWARD																												
FULL																												
MOORING COVER																												
SIDES																												
WALK-THRU CURTAIN																												
CHART LIGHT/LIGHTER																												
C/O MONITOR																												
COMPASS																												
DEPTH SOUNDER																												
DOCKSIDE PWR/SOL. BAT CHG. SWITCH & ADAPT																												
DRINK DECANTER W/ GLASSES																												
DUAL BATTERY SWITCH																												
FIBERGLASS FLOOR LINER																												
FLUSH OUT KIT																												
GAS VAPOR DETECTOR																												
GENERATOR																												
HALON FIREBOY																												
HATCH 12x12 - VENT 2 EACH																												
HATCH SCREEN																												
HEAD, PORTABLE																												
PORTABLE W/PRIVACY CURTAIN																												
PUMP OUT																												
TREATED DISCHARGE																												
HOUR METER																												
ICE MAKER																												
LIGHTS, COURTESY																												
DOCKING																												
SPOT/FLOOD LIGHT REMOTE																												
L-CRAN																												
MICROWAVE																												
PILLOW PACKAGE																												
PROP. STAINLESS (EXCHANGE)																												
RADAR ARCH																												
REFRIGERATOR																												
SEATING, BOLSTER (POWER)																												
BOW FILL-IN CUSHION																												
BUCKET																												
BUCKET & FISHWELL																												
RIGHTING CHAIR																												
L-SHAPED SWIVEL																												
PORT ADJUSTER																												
STERN COUCH																												
SHIP TO SHORE																												
SHOWER CURTAIN																												
SKI TOW (IC)																												
SLX PACKAGE																												
SLX OPTION 2																												
SLX OPTION 3																												
SNAP-IN CARPET																												
STEERING, HYDRAULIC																												
STEREO, REMOTE																												
ADDITIONAL REMOTE																												
HEAD PHONES W/JACK																												
UPGRADE																												
SWIM PLATFORM, FIBERGLASS																												
SWIM PLATFORM, TEAK OR INSERT																												
SYSTEMS MONITOR																												
TABLE																												
TABLE W/EXTRA MOUNT																												
TELEVISION																												
THREE-TONE GEL COAT																												
THRU HULL EXHAUST W/MUFFLER																												
THRU PROP EXHAUST																												
TRANSOM WASH-DOWN & SHOWER																												
TRIM TABS																												
WATER HEATER																												
WINDLASS																												
WINDSHIELD CONSOLE																												
WINDSHIELD WIPER, STD																												
WINDSHIELD WIPER, STD & PORT																												



1



2



3



a



b



c



d



4



5



6



e



f

SLX Package:
(std. Liberator,
Vista, NA Freedom
Quest)

- a. Tri-tone gel-coat
- b. Color coordinated canvas
- c. Premium stereo upgrade
- d. Chart light/lighter
- e. Chrome Vents
- f. Courtesy lights



7



8



11



12



9



10

- 1. Soft-touch radio remote controls (std. Lib., 255/285/315 Vista)
- 2. Portable head w/ privacy curtain (180/200 Hor. Conv. only)
- 3. Transom mounted cockpit washdown with showerhead (255/285/315 Vista)
- 4. "Vista" Monogram bedding/towels pkg.
- 5. Fighting chair (267 Quest); fiberglass swim platform (classic designs except 160 Freedom, std. 267)
- 6. Power Bolster seats (241/251/261 Lib.)
- 7. Depth sounder (Std. 210 Hor., Sun., Quest, Vista, Lib., incl. w/SLX)
- 8. Thru-hull exhaust w/mufflers (Lib. only, Std. 201 2+2)
- 9. Integrated swim platform teak insert
- 10. Dockside Power (std. 285/315 Vista, 261/201 2+2 Lib.)
- 11. Color-coordinated camper canvas.
- 12. Trim tabs (std. Vista, 267 Quest, 261 Lib., Incl. w/twins)



White Base
Tri-Tone WMC - White/Mariner/Charcoal



White Base
Tri-Tone WNC - White/Navy/Charcoal



White Base
Tri-Tone WRC - White/Red/Charcoal



White Base
Tri-Tone WYC - White/Yellow/Charcoal



White Base
Tri-Tone WTC - White/Teal/Charcoal



White Base
Tri-Tone WBC - White/Surgundy/Charcoal

Major Option Packages:

SLX: Includes tri-tone gel coat hull; AM/FM cassette stereo upgrade; depth sounder; courtesy lights; chrome vents; color-matched canvas; chart light/lighter. On Candias, SLX package also includes bow fill-in cushions and table with fore and aft mounts. Availability: Horizons, Candias, Sundowners. Some items are standard on certain boats depending on model and series. (Standard on Vista, Liberator)

Brougham Package:

Includes rear sundeck; driver and passenger molded swivel bucket seats with integrated headrests and side bolsters; full-width stern couch. Availability: Stern drive Horizons, Candias and Sundowners. (Standard on Liberator)

Sport/Fishing:

•Fiberglass cockpit liner. Availability: 200, 210 Horizons; Sundowners, Liberators. (Standard on Quest and Vista)

•Bucket seat on insulated fishwell. Availability: Sundowners. (Standard on Quest)

•Rod storage racks. Availability: Sundowners. (Standard on Quest)

Your Four Winns Dealer

he's one of our most valuable standard features.

Maybe you've seen Four Winns® boats on the water on your lake... or where you vacation... or at a boat show... or going down the road, nested on the back of a distinctive white/navy Four Winns haulaway. Now that we have your attention, we have to connect you with your Four Winns Professional Marine Retailer... the person who can match you and your family to an

We work in his display side by side at his boat shows. We train his service technicians in the care of Four Winns boat systems.



He's our partner... our representative... a valued member of Team Four Winns.

He knows us well, too. He may sit on the Four Winns National Dealer Council... an advisory body that identifies service and quality issues and recommends action. He's been to our plants in Michigan or Texas. He comes to our annual dealer show to test and critique our new models and tell us how to build them "right". We listen, because he is a savvy professional who can tell us what you, the boater, want and need.

To help him do his job better (and help take some of the hassle out of boating for you) we provide stylish, innovative products and plenty of assistance:

- 46 distinctive Four Winns models, from affordable 15-foot runabouts to stately 31-foot live-aboard cruisers (once we get you into a Four Winns boat we expect you to stay with us).

- Over 30 complete and convenient boat/motor/trailer packages with prices starting under \$6800*.



- Fast turn around on replacement parts to get you back on the water fast.

- Standard exclusive Winning Edge™ 3-Year Owner Protection Plan... boating's strongest protection package.

- The colorful, exclusive WINNgear™ line of active wear and accessories.

- And at participating dealers, fashionable Top of the Dock Shoppes and Mall stores, where you can shop boats or the boating look... they're America's boating lifestyle stores.

Becoming a Four Winns Professional Marine Retailer is no easy chore. We make it tough because we want you to be serviced by the strongest, most competent, most courteous and helpful marine expert in your area.

You're special to us. We think you deserve a specialist... your Four Winns Professional Marine Retailer.

*\$6799 suggested list price for the 150 Freedom with 485PL Johnson® or Evinrude® outboard and Four Winns color-matched Sure Load™ trailer, excluding taxes, registration, shipping, dealer prep, and optional features.

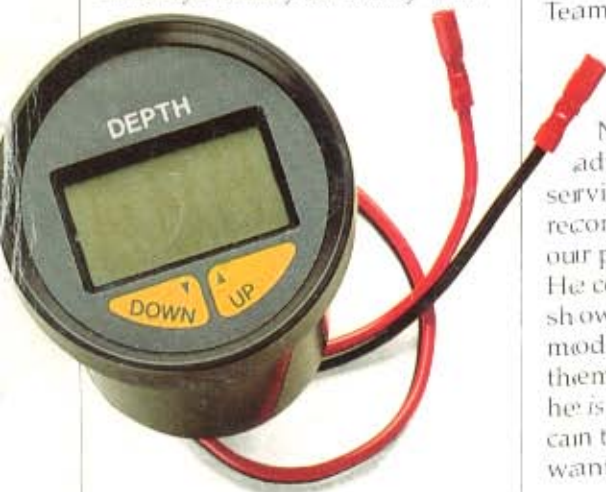

affordable, comfortable, colorful Four Winns boat with the content, value and performance suited to your lifestyle.

We know your Four Winns dealer well. One of our Regional Sales Managers visits with him regularly by phone or in the field, at his dealership. We fax material back and forth on a daily basis.

